



Chipsmall Limited consists of a professional team with an average of over 10 year of expertise in the distribution of electronic components. Based in Hongkong, we have already established firm and mutual-benefit business relationships with customers from,Europe,America and south Asia,supplying obsolete and hard-to-find components to meet their specific needs.

With the principle of “Quality Parts,Customers Priority,Honest Operation,and Considerate Service”,our business mainly focus on the distribution of electronic components. Line cards we deal with include Microchip,ALPS,ROHM,Xilinx,Pulse,ON,Everlight and Freescale. Main products comprise IC,Modules,Potentiometer,IC Socket,Relay,Connector.Our parts cover such applications as commercial,industrial, and automotives areas.

We are looking forward to setting up business relationship with you and hope to provide you with the best service and solution. Let us make a better world for our industry!



Contact us

Tel: +86-755-8981 8866 Fax: +86-755-8427 6832

Email & Skype: info@chipsmall.com Web: www.chipsmall.com

Address: A1208, Overseas Decoration Building, #122 Zhenhua RD., Futian, Shenzhen, China



ADE9000 Arduino-Compatible Energy and Power Quality Measurement Shield

FEATURES

- Arduino-compatible energy and power quality measurement shield with **ADE9000** multiphase energy and power quality monitoring IC
- 3P4W, 3P3W, or 3-wire single phase measurements
- Direct interface with current output current transformers
- Up to 240 V rms nominal line neutral voltage measurement
- Arduino software library
- Calibration and example application sketches

ADDITIONAL EQUIPMENT NEEDED

- Arduino Zero or equivalent
- Current transformers
- Voltage leads
- USB microcable

DOCUMENTS NEEDED

- [ADE9000 data sheet](#)
- [ADE9000 Technical Reference Manual](#)

SOFTWARE NEEDED

- Arduino IDE 1.8.1 or later
- ADE9000** library files

GENERAL DESCRIPTION

The EV-ADE9000SHIELDZ is an Arduino shield compatible with Arduino Zero. The shield can be directly interfaced with current transformers and voltage leads. It enables quick evaluation and prototyping of energy and power quality measurement systems with the **ADE9000**. Arduino library and application examples are provided to simplify implementation of larger systems.

HAZARDOUS HIGH VOLTAGE

This equipment is connected to hazardous line voltages. Exercise proper caution when connecting the sensors and voltage leads. Ensure that the system is enclosed in a protective casing.

CONNECTION DIAGRAM

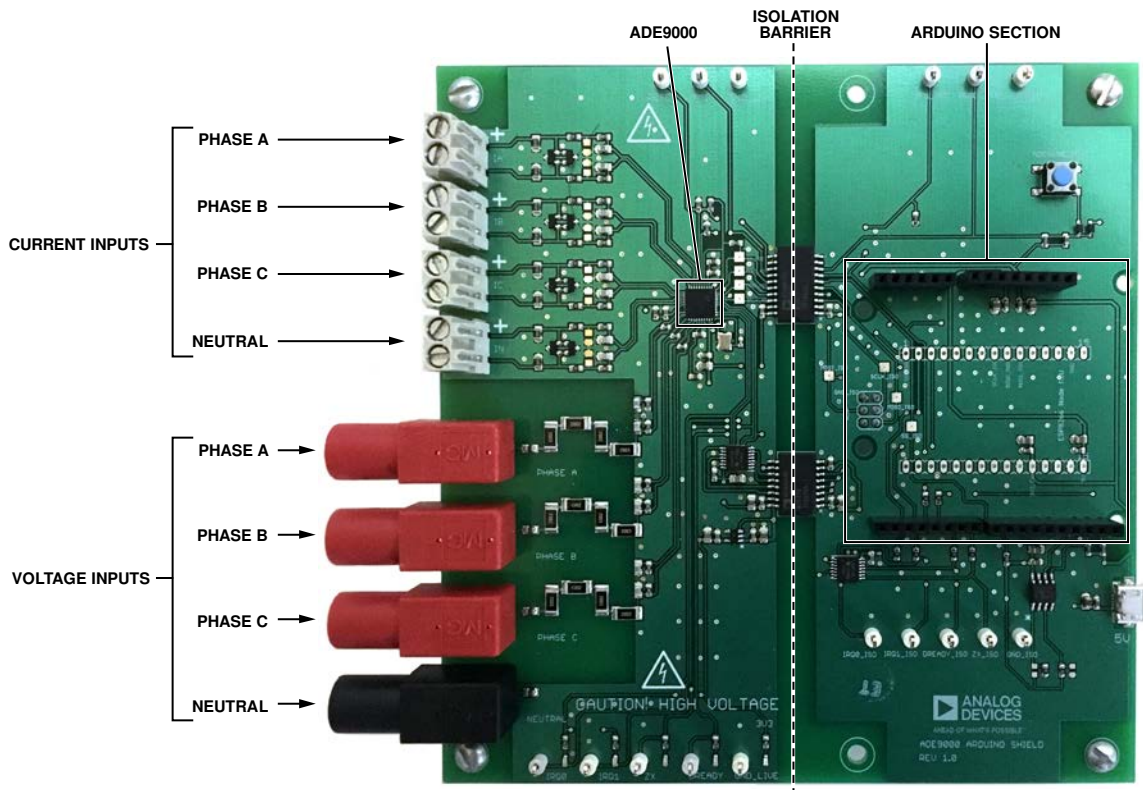

Figure 1. EV-ADE9000SHIELDZ Connection Diagram

TABLE OF CONTENTS

Features	1	Current Sensors	3
Additional Equipment Needed	1	Voltage Sensors	3
Documents Needed	1	Libraries	4
Software Needed	1	Installing the Libraries	4
General Description	1	ADE9000 Arduino Library	4
Hazardous High Voltage	1	Line Voltage Connections	5
Connection Diagram	1	3-Phase, 4-Wire (3P4W) Wye	5
Revision History	2	3-Phase, 3-Wire (3P3W) Delta	6
Module Hardware	3	Evaluation Board Schematics	7
Powering the ADE9000 Shield	3	Components	9
Arduino Zero	3	Bill of Materials	10
ESP8266 WiFi Module	3		

REVISION HISTORY

1/2018—Revision 0: Initial Version

MODULE HARDWARE

POWERING THE ADE9000 SHIELD

The EV-ADE9000SHIELDZ requires 3.3 V and 5 V. It is powered from the 3.3 V power pin and 5 V power pin from Arduino or ESP8266.

ARDUINO ZERO

The ADE9000 shield has Arduino R3 headers directly compatible with Arduino Uno and Arduino Zero. Using the EV-ADE9000SHIELDZ with Arduino Zero or equivalent is recommended. The Arduino pins used by the ADE9000 shield are given in Table 1.

Table 1. Arduino GPIO Connections

Arduino Pin	ADE9000 Signal	Type
ICSP-SCK	SCLK	SPI
ICSP-MISO	MISO	SPI
ICSP-MOSI	MOSI	SPI
GPIO 8	CS (pulled up)	SPI, output
GPIO 4	PM1 (pulled down)	Output
GPIO 5	RESET (pulled up)	Output
GPIO 2	IRQ0	Input (interrupt)
GPIO 3	IRQ1	Input (interrupt)
GPIO 6	CF4/DREADY/EVENT	Input (interrupt)
GPIO 7	CF3/ZX	Input (interrupt)
3.3 V	Not applicable	Power
5 V	Not applicable	Power

ESP8266 WIFI MODULE

The shield can also be used with the ESP8266 WiFi module. The on-board header makes the shield compatible with ESP8266 ESP-12E NodeMCU. To use ESP8266, do the following:

- Solder 15-pin headers (SV1 and SV2)
- Populate 0 Ω resistors on R49, R51, R67, and R68 located on the bottom of the board to establish an SPI connection.
- Optionally, supply external 5 V at J9 if the computer USB does not provide enough current during debugging.

The ESP8266 pins used by the EV-ADE9000SHIELDZ are given in Table 2.

Table 2. Arduino General-Purpose Input/Output (GPIO) Connections

ESP8266 Pin	ADE9000 Signal	Type
D5 (GPIO 14)	SCLK	SPI
D6 (GPIO 12)	MISO	SPI
D7 (GPIO 13)	MOSI	SPI
D0 (GPIO 16)	CS (pulled up)	SPI, output
D8 (GPIO 15)	PM1 (pulled down)	Output
D1 (GPIO 5)	IRQ0	Input
D2 (GPIO 4)	IRQ1	Input
3.3 V	Not applicable	Power
5 V	Not applicable	Power

CURRENT SENSORS

The EV-ADE9000SHIELDZ is designed to work directly with current output current transformers (CTs). Connect the CT leads to the SL1, SL2, SL3, and SL4 terminal blocks.

Current Output CTs

The EV-ADE9000SHIELDZ has on-board burden resistors in differential configuration to allow direct connection with current output CTs. With a typical 2500:1 CT, the maximum recommended current is 86 A rms. Refer to the ADE9000 Technical Reference Manual to modify burden resistors for different current ranges.

Voltage Output CTs

To use voltage output CTs, remove burden Resistors R1, R2, R3, R4, R10, R11, R19, and R20. The maximum recommended CT output voltage is ± 0.353 V rms.

Rogowski Coils

To use Rogowski coils with EV-ADE9000SHIELDZ, do the following:

- Remove burden Resistors R1, R2, R3, R4, R10, R11, R19, and R20.
- Replace 0 Ω Resistors R5, R6, R14, R15, R21, R22, R23, and R24 with 100 Ω resistors.
- Populate C15, C16, C17, C18, C21, C22, C26, and C28 with 22 nF ceramic C0G grade capacitors.
- In the ADE9000API.h file, do the following:
 - Set the INTEN and ININTEN bits in the CONFIG0 register.
 - Set DICOEFF to 0xFFFFE000.
 - If the Rogowski output signal is too low, increase the PGA gain.

VOLTAGE SENSORS

The EV-ADE9000SHIELDZ has on-board resistor dividers to attenuate the incoming input voltage. The attenuation factor is 801. Do not exceed the 240 V rms nominal line to neutral voltage in the 3-phase, 4-wire (3P4W) wye configuration. In 3-wire delta configuration, when Phase B is used as the reference, do not exceed 250 V rms line to line voltage. There are 4 mm banana jacks on board to connect the voltage inputs. Use TPI A079 or equivalent leads with alligator clips to connect the voltage inputs.

LIBRARIES

The EV-ADE9000SHIELDZ Arduino libraries provide basic functions to access the [ADE9000](#). The calibration sketch can be used to calibrate the [ADE9000](#) using an accurate source.

INSTALLING THE LIBRARIES

Download ADE9000ArduinoLibrary.zip.

Install the [ADE9000](#) Arduino library, as shown in Figure 2.

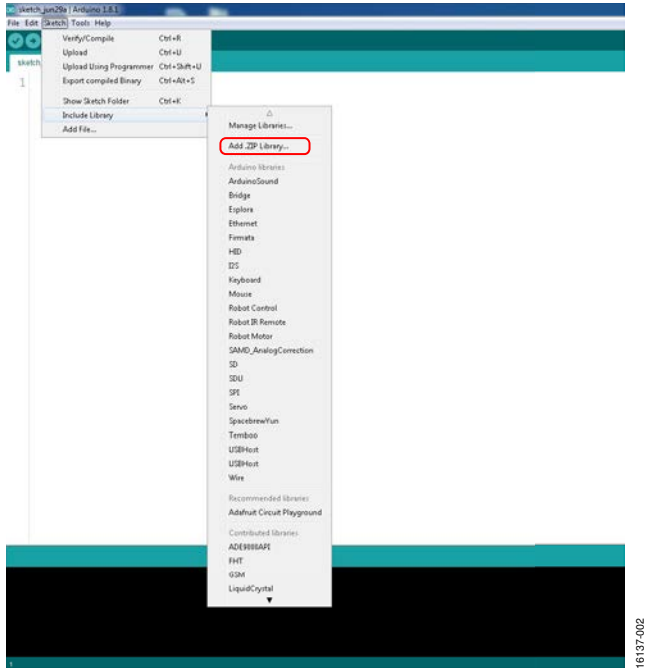

Figure 2. Installing Arduino Library. Original Content Hosted by Arduino, Available at www.arduino.cc; Content from Arduino Republished Here Under the Creative Commons Attribution-ShareAlike 3.0 Unported License, License Available At www.arduino.cc/en/Main/CopyrightNotice; All Other Rights Reserved by Analog Devices, Inc.

ADE9000 ARDUINO LIBRARY

ADE9000API.cpp

The ADE9000API.cpp file contains functions to communicate, initialize, and read calculated parameters from the chip.

ADE9000API.h

The ADE9000API.h file contains register constants that are written into the device by the SetupADE9000 function.

ADE9000CalibrationInputs.h

The ADE9000CalibrationInputs.h file contains the system information used to calibrate the [ADE9000](#). It is used by the [ADE9000](#) Calibration.ino sketch to compute the calibration constants. The calibration constants are stored in the EEPROM.

ADE9000 Application Examples

The application examples demonstrate the use of functions in ADE9000API.cpp and ADE9000API.h library files to obtain the parameters calculated by the [ADE9000](#). Connect Arduino Zero, and compile and load the application examples to start measuring energy and power quality.

LINE VOLTAGE CONNECTIONS

The EV-ADE9000SHIELDZ is connected to hazardous line voltages. Exercise proper caution when connecting the sensors and voltage leads. Ensure that the system is enclosed in a protective casing.

3-PHASE, 4-WIRE (3P4W) WYE

The 3P4W wye connection is shown in Figure 3. Do not exceed the nominal voltage of a 240 V rms line to neutral in wye configuration.

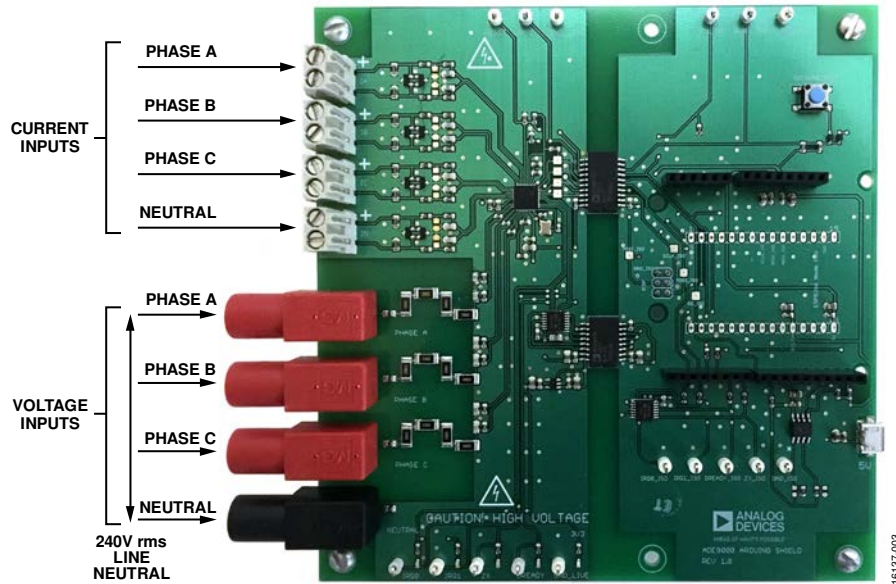

Figure 3. 3P4W Wye Connection

3-PHASE, 3-WIRE (3P3W) DELTA

The 3P3W delta connection is shown in Figure 4. Phase B is used as the reference; therefore, the neutral channel on the board is connected to Phase B. Do not exceed the 250 V rms

line to line voltage in the delta configuration. When using the delta configuration, take the following actions in the ADE9000API.h file:

- Set VCONSEL to 001 so that $V_B = V_A - V_C$.
- Set ICONSEL to 1 so that $I_B = -I_A - I_C$.

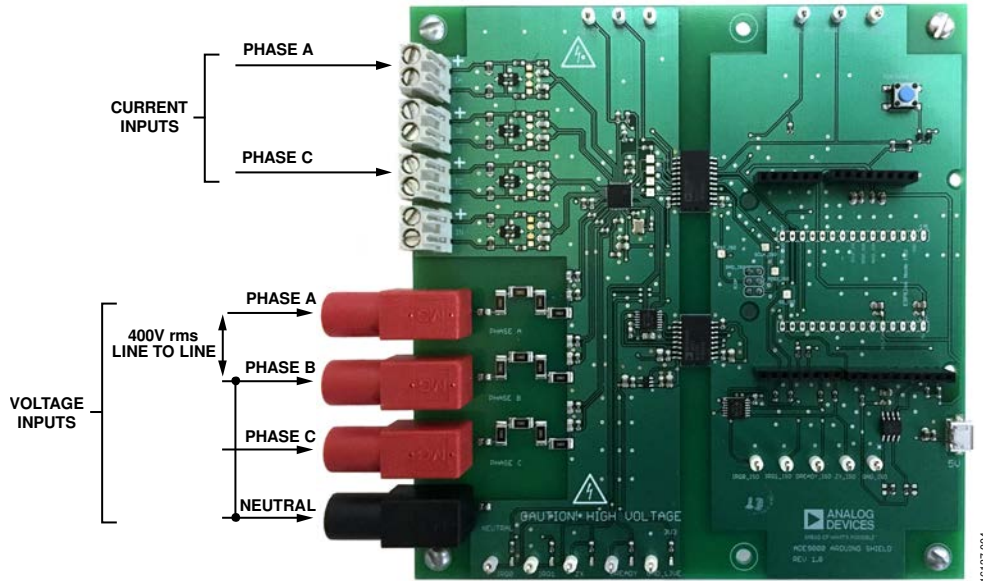

Figure 4. 3P3W Delta Connection

EVALUATION BOARD SCHEMATICS

ALL ANTIALISING CAPS ARE COG NP0 GRADE

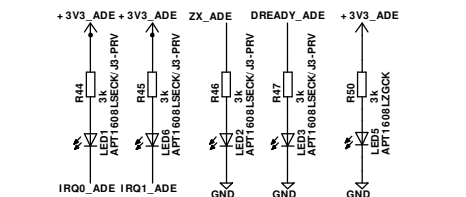
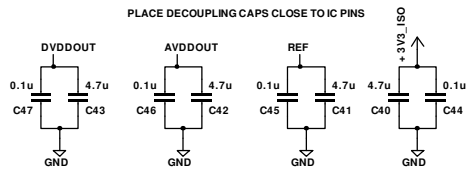
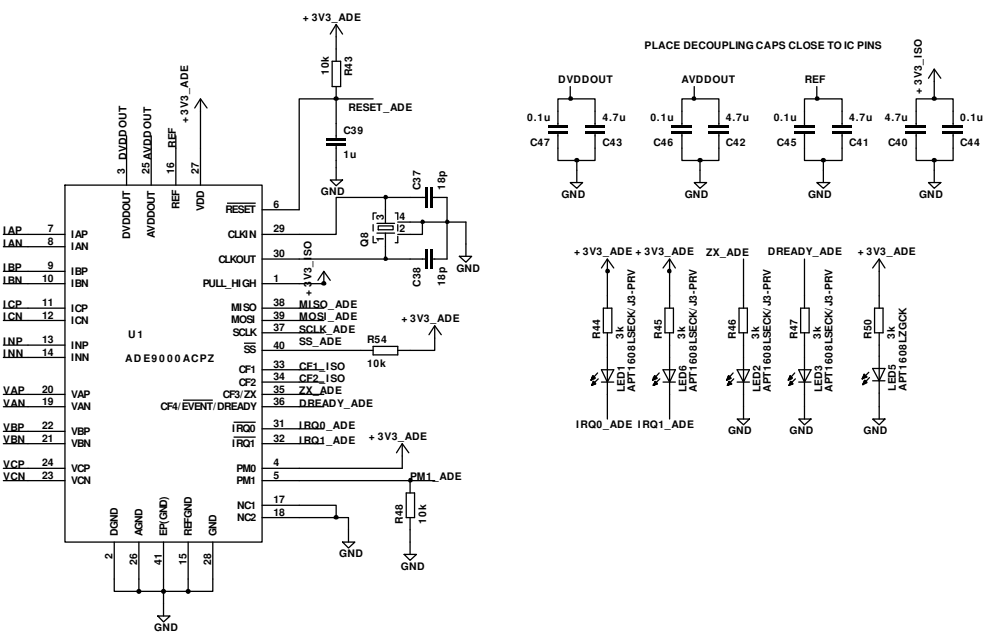
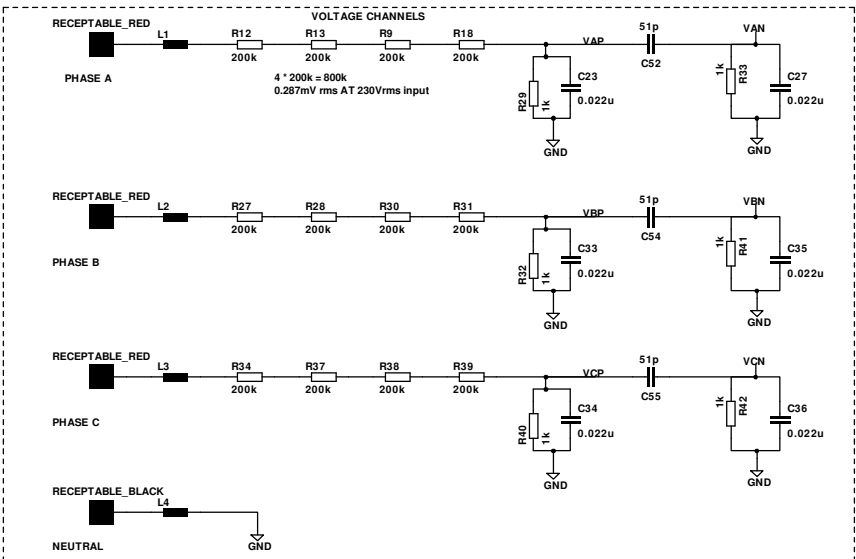
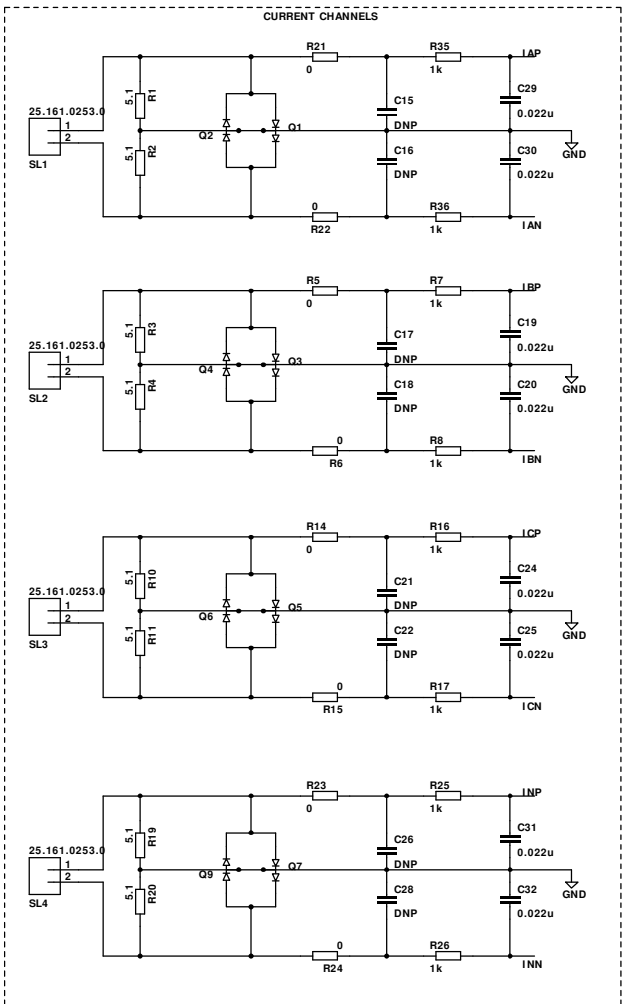

Figure 5. EV-ADE9000SHIELDZ Schematic Sheet 1

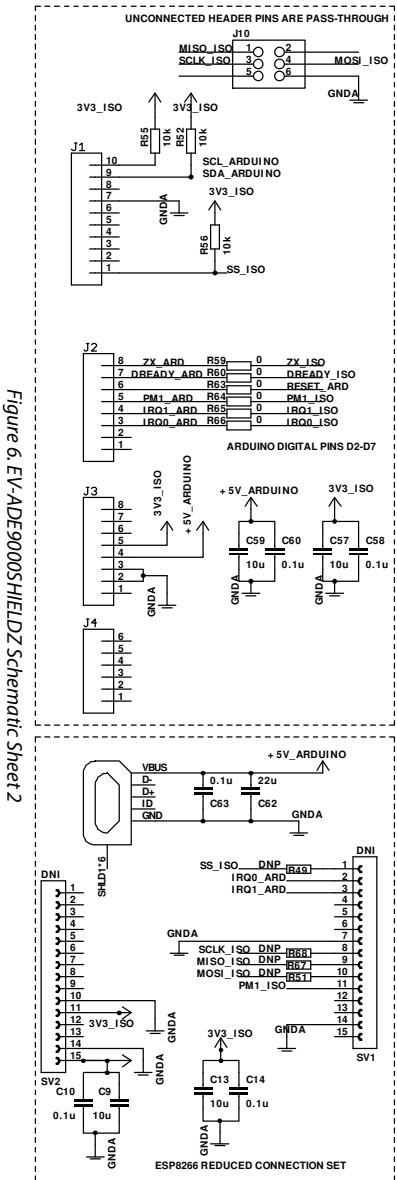
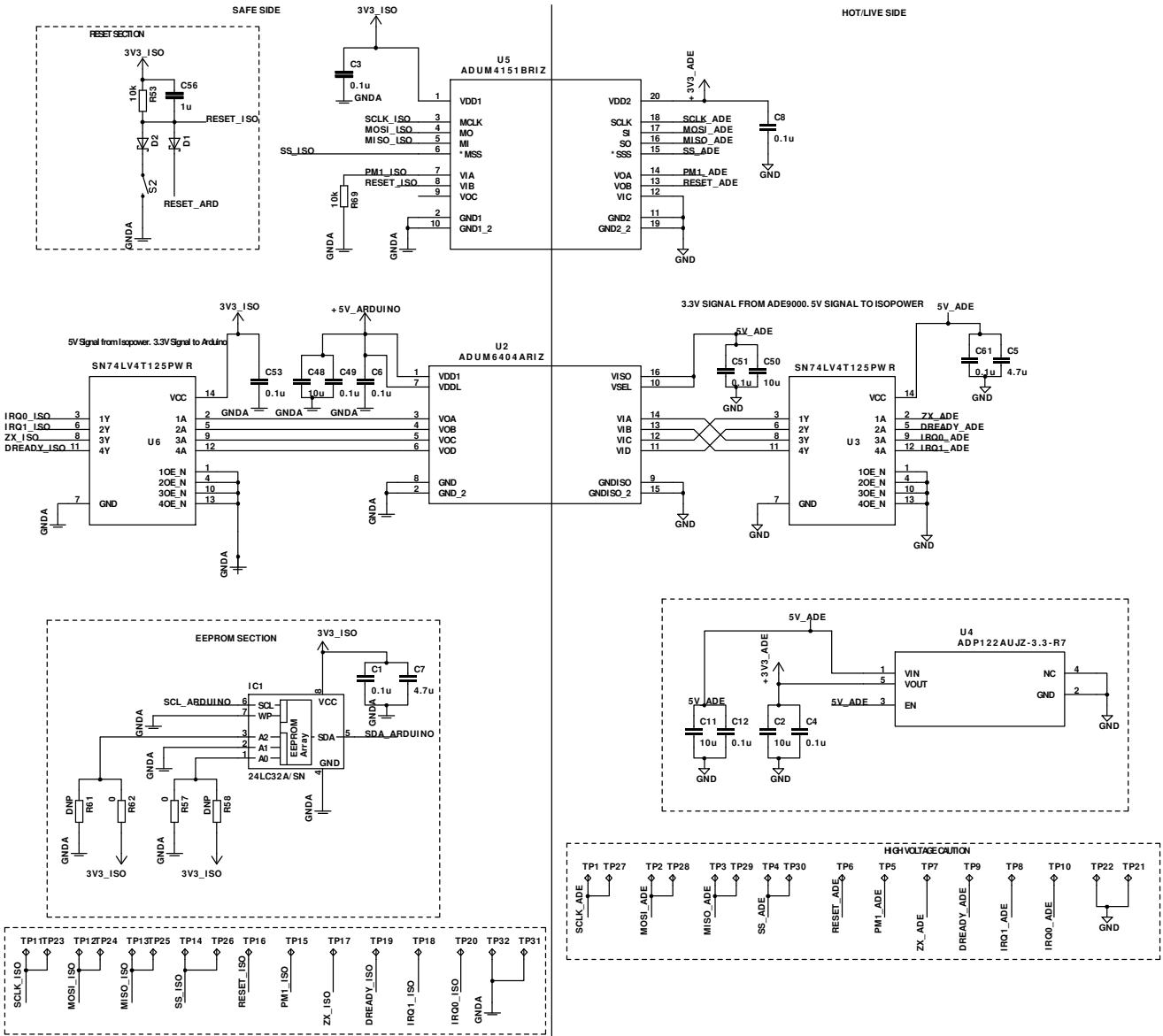

Figure 6. EV-ADE9000SHIELDZ Schematic Sheet 2

COMPONENTS

Table 3 and Table 4 list required current transformers, voltage leads, and clips. Equivalent components can also be used.

Table 3. Required Current Transformers

Manufacturer	Part No.
TDK	CCT272440
VAC	T60404-E4626-X002

Table 4. Required Voltage Leads and Clips

Manufacturer	Part No.
Leads-TPI	A079
Clips-TPI	A058
Clips-Ponoma Electronics	6041B

BILL OF MATERIALS

Qty	Designator	Description	Manufacturer	Part No.
16	R5, R6, R14, R15, R21 to R24, R57, R59, R60, R62 to R66	Resistors, 0 Ω, 0.1 W, 0603 SMT, RoHS	Yageo	RC0603JR-070RL
8	R43, R48, R52 to R56, R69	Resistors, 10 kΩ, 0.1 W, 0603 SMT, RoHS	Yageo	RC0603JR-0710KL
14	R7, R8, R16, R17, R25, R26, R29, R32, R33, R35, R36, R40 to R42	Resistors, 1 kΩ, 0.1 W, 0603 SMT, RoHS	Yageo	RC0603FR-071KL
12	R9, R12, R13, R18, R27, R28, R30, R31, R34, R37 to R39	Resistors, 200 kΩ, 0.1 W, 2010 SMT, RoHS	Rohm Semiconductor	MCR50JZHF2003
5	R44 to R47, R50	Resistors, 3 kΩ, 0.1 W, 0603 SMT, RoHS	Yageo	RC0603FR-073KL
8	R1 to R4, R10, R11, R19, R20	Resistors, 5.1 Ω, 0.1 W, 0805 SMT, RoHS	TE Connectivity Passive Product	CPF0805B5R1E1
12	C19, C20, C24, C25, C29 to C36	Capacitors, 0.022 μF, 50 V, 5%, 0805 SMT, RoHS, COG	TDK Corporation	CGA4J2C0G1H223J125AA
19	C1, C3, C4, C6, C8, C10, C12, C14, C44 to C47, C49, C51, C53, C58, C60, C61, C63	Capacitors, 0.1 μF, 25 V, 10%, 0603 SMT, RoHS, X7R	Murata Electronics North America	GRM188R71E104KA01D
8	C2, C9, C11, C13, C48, C50, C57, C59	Capacitors, 10 μF, 16 V, 10%, 0805 SMT, RoHS, X7R	Samsung Electro-Mechanics America, Inc.	CL21B106KOQNNNE
2	C37, C38	Capacitors, 18 pF, 50 V, 1%, 0402 SMT, RoHS COG	Murata Electronics North America	GRM1555C1H180FA01D
2	C39, C56	Capacitors, 1 μF, 50 V, 10%, 0603 SMT, RoHS, X7R	Taiyo Yuden	UMK107AB7105KA-T
1	C62	Capacitors, 22 μF, 25 V, 20%, 0805 SMT, RoHS, X5R	Murata Electronics North America	GRM21BR61E226ME44L
3	C5, C7, C40	Capacitors, 4.7 μF, 25 V, 10%, 0805 SMT, RoHS, X5R	Murata Electronics North America	GRM21BR61E475KA12L
3	C41 to C43	Capacitors, 4.7 μF, 25 V, 10%, 0603 SMT, RoHS, X5R	TDK Corporation	C1608X5R1E475M080AC
3	C52, C54, C55	Capacitors, 51 pF, 50 V, 5%, 0402 SMT, RoHS, COG	Samsung Electro-Mechanics America, Inc.	CL05C510JB5NNNC
4	L1 to L4	Ferrite bead, 1500 Ω, 0805 SMT	Murata Electronics North America	BLM21BD152SN1D
1	J8	VOLTAGE_SOCKET_4MM_BLACK	STAUBLI/Multi Contact	23.3200-21
3	J5 to J7	VOLTAGE_SOCKET_4MM_RED	STAUBLI/Multi Contact	23.3200-22
1	IC1	IC, EEPROM, 32 KBIT, 400 KHz, 8-lead SOIC, 3.9 mm	Microchip Technology	24LC32AT-I/SN
4	LED1 to LED3, LED6	LED, 1.8 V, 2 mA, red, 0603	Kingbright	APT1608LSECK/J3-PRV
1	LED5	LED, 2.65 V, 2 mA, green, 0603	Kingbright	APT1608LZGCK
2	D1, D2	Diodes, Schottky, 30 V, 100 mA, SOD323	Diodes Incorporated	BAT54WS-7-F
1	Q8	Crystal, 24.576 MHz, 12 pF, 4-SMD	ECS Inc.	ECS-245.7-12-33Q-JES-TR
8	Q1 to Q7, Q9	Diodes, dual series connection, 100 V, SOT-23-3	Fairchild/ON Semiconductor	MMBD4148SE
1	J9	Connector, receptable, USB MICRO AB, SMD	Hirose Electric Co Ltd	ZX62-AB-5PA(31)
4	SL1 to SL4	Terminal blocks, 2 position, 5 mm pitch, through hole	On Shore Technology Inc.	ED350/2
1	U1	IC, ADE9000, poly phase metering AFE, 40-lead LFCSP	Analog Devices, Inc.	ADE9000ACPZ
1	U4	IC, ADP122, linear regulator, 3.3 V, 5-lead TSOT	Analog Devices, Inc.	ADP122AUJZ-3.3-R7

Qty	Designator	Description	Manufacturer	Part No.
1	U5	IC, ADuM4151 , SPI isolator, 17 MHz, 2/1 Data, 20-lead SOIC	Analog Devices, Inc.	ADuM4151BRIZ-RL
1	U2	IC, ADuM6404 , ISO power, 4 Channels, 16-lead SOIC	Analog Devices, Inc.	ADuM6404ARIZ
1	S2	Switch, tactile SPST-NO, surface-mount, 6 mm x 6 mm, 4 lead	C&K	PTS645SM43SMTR92 LFS
2	U3, U6	ICs, SN74LV4T125, level translator, noninverting, 14-TSSOP	Texas Instruments	SN74LV4T125PWR
16	TP5 to TP10, TP15 to TP22, TP31, TP32	Test points, 0.063", white	Keystone Electronics	5007
1	J10	Connector, receptable, 3 x 2, 0.1" pitch	Sullins Connector Solutions	PPTC032LFBN-RC
1	J4	Connector, receptable, 6 x 1, 0.1" pitch, long tail	Samtec Inc.	311-43-106-41-001000
2	J2, J3	Connectors, receptable, 8 x 1, 0.1" pitch, long tail	Samtec Inc.	311-43-108-41-001000
1	J1	Connector, receptable, 10 x 1, 0.1" pitch, long tail	Samtec Inc.	311-43-110-41-001000
16	TP1 to TP4, TP11 to TP14, TP23 to TP30	Test pad		
6	H1 to H6	Mount hole		
6	R49, R51, R58, R61, R67, R68	Do not install (DNI)		
8	C15 to C18, C21, C22, C26, C28	DNI		
2	SV1, SV2	DNI	Sullins Connector Solutions	PPTC151LFBN-RC



ESD Caution

ESD (electrostatic discharge) sensitive device. Charged devices and circuit boards can discharge without detection. Although this product features patented or proprietary protection circuitry, damage may occur on devices subjected to high energy ESD. Therefore, proper ESD precautions should be taken to avoid performance degradation or loss of functionality.

Legal Terms and Conditions

By using the evaluation board discussed herein (together with any tools, components documentation or support materials, the "Evaluation Board"), you are agreeing to be bound by the terms and conditions set forth below ("Agreement") unless you have purchased the Evaluation Board, in which case the Analog Devices Standard Terms and Conditions of Sale shall govern. Do not use the Evaluation Board until you have read and agreed to the Agreement. Your use of the Evaluation Board shall signify your acceptance of the Agreement. This Agreement is made by and between you ("Customer") and Analog Devices, Inc. ("ADI"), with its principal place of business at One Technology Way, Norwood, MA 02062, USA. Subject to the terms and conditions of the Agreement, ADI hereby grants to Customer a free, limited, personal, temporary, non-exclusive, non-sublicensable, non-transferable license to use the Evaluation Board FOR EVALUATION PURPOSES ONLY. Customer understands and agrees that the Evaluation Board is provided for the sole and exclusive purpose referenced above, and agrees not to use the Evaluation Board for any other purpose. Furthermore, the license granted is expressly made subject to the following additional limitations: Customer shall not (i) rent, lease, display, sell, transfer, assign, sublicense, or distribute the Evaluation Board; and (ii) permit any Third Party to access the Evaluation Board. As used herein, the term "Third Party" includes any entity other than ADI, Customer, their employees, affiliates and in-house consultants. The Evaluation Board is NOT sold to Customer; all rights not expressly granted herein, including ownership of the Evaluation Board, are reserved by ADI. CONFIDENTIALITY. This Agreement and the Evaluation Board shall all be considered the confidential and proprietary information of ADI. Customer may not disclose or transfer any portion of the Evaluation Board to any other party for any reason. Upon discontinuation of use of the Evaluation Board or termination of this Agreement, Customer agrees to promptly return the Evaluation Board to ADI. ADDITIONAL RESTRICTIONS. Customer may not disassemble, decompile or reverse engineer chips on the Evaluation Board. Customer shall inform ADI of any occurred damages or any modifications or alterations to the Evaluation Board, including but not limited to soldering or any other activity that affects the material content of the Evaluation Board. Modifications to the Evaluation Board must comply with applicable law, including but not limited to the RoHS Directive. TERMINATION. ADI may terminate this Agreement at any time upon giving written notice to Customer. Customer agrees to return to ADI the Evaluation Board at that time. LIMITATION OF LIABILITY. THE EVALUATION BOARD PROVIDED HEREUNDER IS PROVIDED "AS IS" AND ADI MAKES NO WARRANTIES OR REPRESENTATIONS OF ANY KIND WITH RESPECT TO IT. ADI SPECIFICALLY DISCLAIMS ANY REPRESENTATIONS, ENDORSEMENTS, GUARANTEES, OR WARRANTIES, EXPRESS OR IMPLIED, RELATED TO THE EVALUATION BOARD INCLUDING, BUT NOT LIMITED TO, THE IMPLIED WARRANTY OF MERCHANTABILITY, TITLE, FITNESS FOR A PARTICULAR PURPOSE OR NON-INFRINGEMENT OF INTELLECTUAL PROPERTY RIGHTS. IN NO EVENT WILL ADI AND ITS LICENSORS BE LIABLE FOR ANY INCIDENTAL, SPECIAL, INDIRECT, OR CONSEQUENTIAL DAMAGES RESULTING FROM CUSTOMER'S POSSESSION OR USE OF THE EVALUATION BOARD, INCLUDING BUT NOT LIMITED TO LOST PROFITS, DELAY COSTS, LABOR COSTS OR LOSS OF GOODWILL. ADI'S TOTAL LIABILITY FROM ANY AND ALL CAUSES SHALL BE LIMITED TO THE AMOUNT OF ONE HUNDRED US DOLLARS (\$100.00). EXPORT. Customer agrees that it will not directly or indirectly export the Evaluation Board to another country, and that it will comply with all applicable United States federal laws and regulations relating to exports. GOVERNING LAW. This Agreement shall be governed by and construed in accordance with the substantive laws of the Commonwealth of Massachusetts (excluding conflict of law rules). Any legal action regarding this Agreement will be heard in the state or federal courts having jurisdiction in Suffolk County, Massachusetts, and Customer hereby submits to the personal jurisdiction and venue of such courts. The United Nations Convention on Contracts for the International Sale of Goods shall not apply to this Agreement and is expressly disclaimed.

©2018 Analog Devices, Inc. All rights reserved. Trademarks and registered trademarks are the property of their respective owners.
UG16137-0-1/18(0)



www.analog.com