



Chipsmall Limited consists of a professional team with an average of over 10 year of expertise in the distribution of electronic components. Based in Hongkong, we have already established firm and mutual-benefit business relationships with customers from,Europe,America and south Asia,supplying obsolete and hard-to-find components to meet their specific needs.

With the principle of “Quality Parts,Customers Priority,Honest Operation,and Considerate Service”,our business mainly focus on the distribution of electronic components. Line cards we deal with include Microchip,ALPS,ROHM,Xilinx,Pulse,ON,Everlight and Freescale. Main products comprise IC,Modules,Potentiometer,IC Socket,Relay,Connector.Our parts cover such applications as commercial,industrial, and automotives areas.

We are looking forward to setting up business relationship with you and hope to provide you with the best service and solution. Let us make a better world for our industry!



## Contact us

Tel: +86-755-8981 8866 Fax: +86-755-8427 6832

Email & Skype: info@chipsmall.com Web: www.chipsmall.com

Address: A1208, Overseas Decoration Building, #122 Zhenhua RD., Futian, Shenzhen, China



## **ADE9153A Energy Measurement Shield with *mSure* Autocalibration**

### **FEATURES**

**Arduino-compatible, single-phase energy measurement shield with the [ADE9153A](#)**

**Onboard shunt for line current measurement**

**Nominal current: 5 A**

**Maximum current: 10 A**

**Up to 240 V rms nominal line neutral voltage measurement**

**Arduino software library**

***mSure* autocalibration and example application sketches**

### **ADDITIONAL EQUIPMENT NEEDED**

**Arduino Uno, Arduino Zero, or equivalent**

**Voltage quick connect leads**

**USB micro cable**

**0.250 inch quick connect female connector**

### **DOCUMENTS**

**[ADE9153A data sheet](#)**

**[ADE9153A Technical Reference Manual](#)**

### **SOFTWARE**

**Arduino IDE 1.8.4 or later**

**[ADE9153A library files](#)**

### **GENERAL DESCRIPTION**

The EV-ADE9153ASHIELDZ is an Arduino shield compatible with Arduino Uno, Arduino Zero, or ESP8266. The shield has an on-board shunt resistor for line current measurement and enables quick evaluation and prototyping of energy measurement systems that use the [ADE9153A](#). Arduino library and application examples are provided on the [ADE9153A](#) product page to simplify implementation of larger systems. Using *mSure*® autocalibration, the shield can be calibrated to measure energy with 1% accuracy over the dynamic range without the need for expensive calibration equipment.

### **HAZARDOUS HIGH VOLTAGE CAUTION**

The equipment described in this user guide is connected to hazardous line voltages. Use proper caution when connecting the sensors and voltage leads. Ensure that the system is enclosed in a protective casing.

**TABLE OF CONTENTS**

Features .....	1	ESP8266 WiFi System on Chip (SOC) .....	4
Additional Equipment Needed .....	1	Current Sensors .....	4
Documents .....	1	Voltage Sensors .....	4
Software .....	1	Libraries .....	5
General Description .....	1	Installing the Libraries .....	5
Hazardous High Voltage Caution .....	1	ADE9153A Arduino Library .....	5
Revision History .....	2	Line Voltage Connections .....	6
Conection Diagram .....	3	Hazardous High Voltage .....	6
Module Hardware .....	4	Single-Phase Line and Neutral Connections .....	6
Powering the ADE9153A Shield .....	4	Evaluation Board Schematic .....	7
Arduino Uno and Arduino Zero .....	4		

**REVISION HISTORY**

2/2018—Revision 0: Initial Version

# CONNECTION DIAGRAM

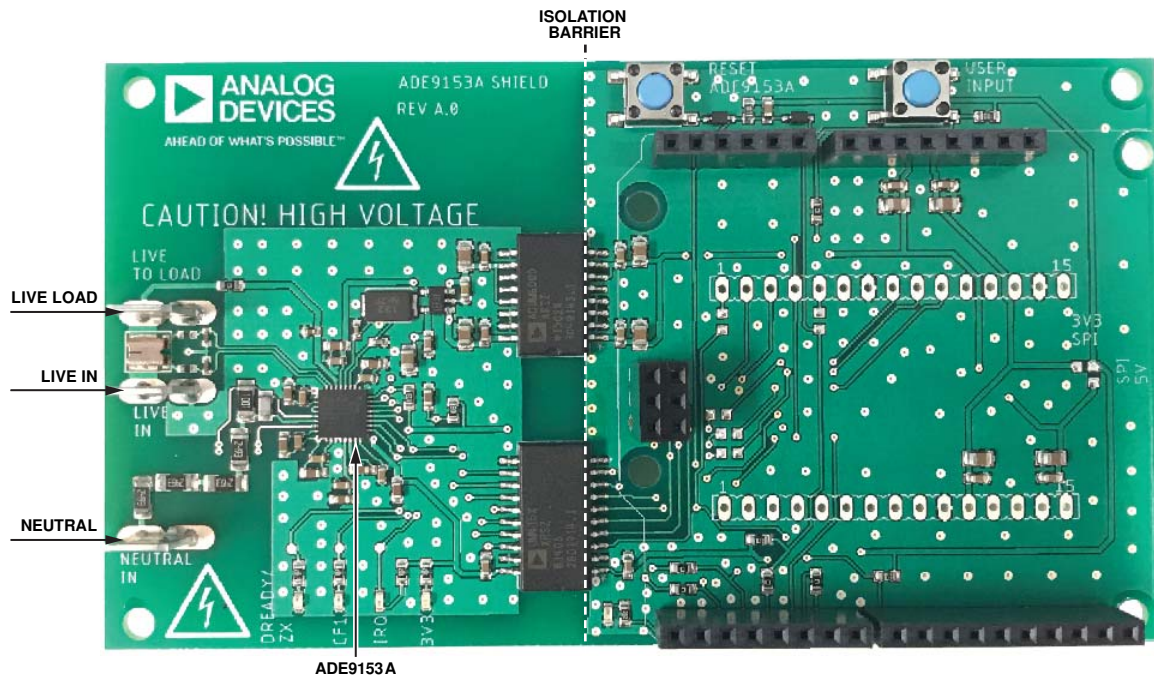

Figure 1. EV-ADE9153ASHIELDZ Connection Diagram

## MODULE HARDWARE

### POWERING THE ADE9153A SHIELD

The EV-ADE9153ASHIELDZ is powered from 5 V coming from Arduino. By default, the 5 V SPI jumper is connected and the board can be directly connected to Arduino Uno. To use Arduino Zero or any 3.3 V microcontroller unit (MCU), disconnect the 5 V SPI jumper and connect a 3 V SPI jumper to ensure that the correct voltage is applied on the Arduino pins.

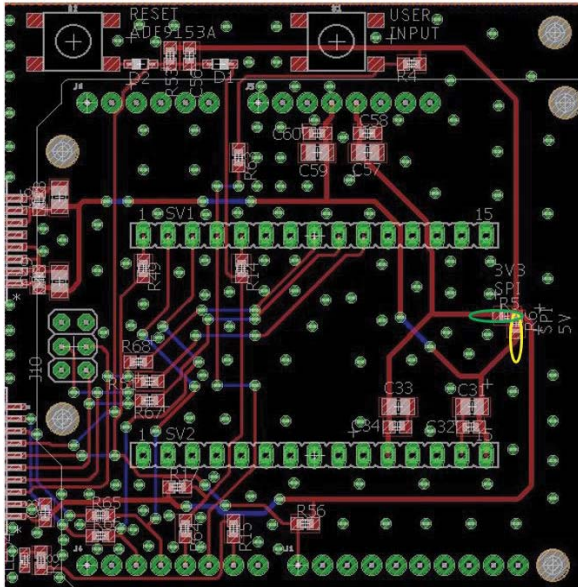

Figure 2. DC Power Supply Selection

### ARDUINO UNO AND ARDUINO ZERO

The ADE9153A shield has Arduino R3 headers directly compatible with Arduino Uno and Arduino Zero. The Arduino pins used by the ADE9153A shield are described in Table 1.

Table 1. Arduino General-Purpose Input/Output (GPIO) Connections

Arduino Pin	ADE9153A Signal	Type
ICSP-SCK	SCLK	Serial peripheral interface (SPI)
ICSP-MISO	MISO	SPI
ICSP-MOSI	MOSI	SPI
GPIO 8	$\overline{SS}$ (pulled up)	SPI output
GPIO 4	$\overline{RESET}$	Output
GPIO 5	User button input	Input
GPIO 2	ZX/DREADY/CF2	Input (interrupt)
GPIO 3	$\overline{IRQ}$	Input (interrupt)
5 V	Not applicable	Power
3.3 V	Not applicable	Power

### ESP8266 WIFI SYSTEM ON CHIP (SOC)

The shield can also be used with the ESP8266 WiFi SOC. The on-board header makes the shield compatible with the ESP8266 ESP-12E Node MCU. To use the ESP8266, perform the following actions (note that these actions do not need to be performed in order):

- Populate the 15-pin headers, SV1 and SV2.
- Disconnect the 5 V SPI jumper and connect a 3 V SPI jumper to ensure that the correct voltage is applied, as shown in Figure 2.
- Populate 0  $\Omega$  resistors on R49, R51, R67, and R68 to establish the SPI connection. Populate R14 to establish the  $\overline{RESET}$  connection

The ESP8266 pins used by the EV-ADE9153ASHIELDZ are described in Table 2.

Table 2. ESP8266 GPIO Connections

ESP8266 Pin	ADE9153A Signal	Type
D5 (GPIO 14)	SCLK	SPI
D6 (GPIO 12)	MISO	SPI
D7 (GPIO 13)	MOSI	SPI
D0 (GPIO 16)	$\overline{SS}$ (pulled up)	SPI output
D4 (GPIO 2)	$\overline{RESET}$	Output
D1 (GPIO 5)	$\overline{IRQ}$	Input
D2 (GPIO 4)	ZX/DREADY/CF2	Input
D3 (GPIO 0)	User button input	Input
5 V	Not applicable	Power
3.3 V	Not applicable	Power

### CURRENT SENSORS

The EV-ADE9153ASHIELDZ has an on-board, 1 m $\Omega$  shunt resistor. The nominal current through the shunt is 5 A rms and the maximum allowed current is 10 A rms with a programmable gain amplifier (PGA) gain value of 16.

### VOLTAGE SENSORS

The EV-ADE9153ASHIELDZ has on-board resistor dividers to attenuate the incoming input voltage. The attenuation factor is 1001. Do not exceed a 240 V rms nominal line to neutral voltage.

## LIBRARIES

The EVAL-ADE9153ASHIELD Arduino libraries provide basic functions to access the [ADE9153A](#). Use the calibration sketch to calibrate the [ADE9153A](#) using an accurate source.

### INSTALLING THE LIBRARIES

To install the libraries,

1. Download [ADE9153AAPI.zip](#).
2. Install the [ADE9153A](#) Arduino library as shown in Figure 3.

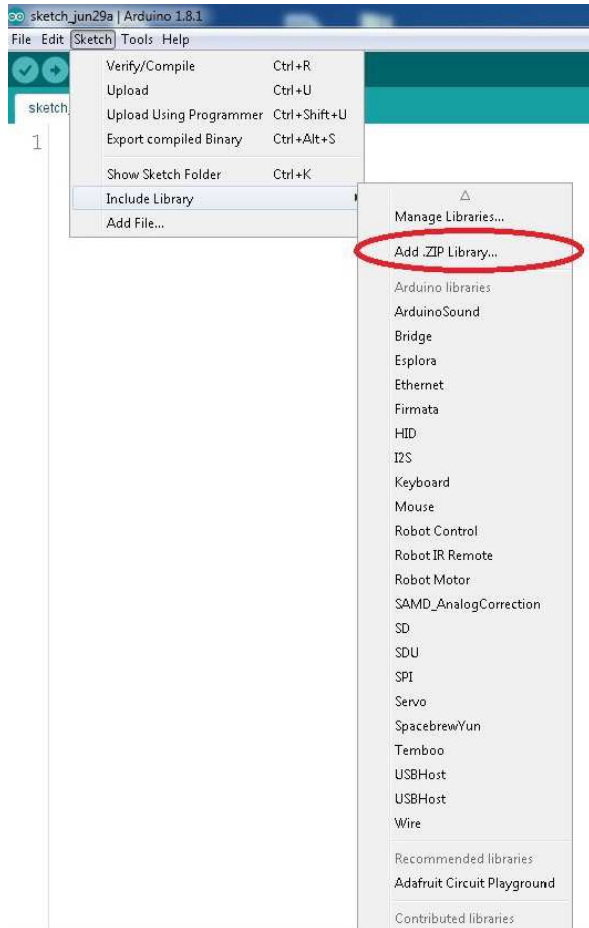

Figure 3. Installing the Arduino Library

### ADE9153A ARDUINO LIBRARY

#### ADE9153AAPI.cpp

The [ADE9153AAPI.cpp](#) file contains functions to communicate, initialize, and read calculated parameters from the chip.

#### ADE9153AAPI.h

The [ADE9153AAPI.h](#) file contains register constants that are written into the device by the set up [ADE9153A](#) function.

#### ADE9153A Application Examples

The application examples demonstrate the use of functions in the [ADE9153AAPI.cpp](#) and [ADE9153AAPI.h](#) library files to obtain the parameters calculated by the [ADE9153A](#). Connect Arduino Zero and compile and load the application examples to start energy and power quality measurements.

## LINE VOLTAGE CONNECTIONS

### HAZARDOUS HIGH VOLTAGE

The equipment described in this user guide is connected to hazardous line voltages. Exercise proper caution when connecting the sensors and voltage leads. Ensure that the system is enclosed in a protective casing.

### SINGLE-PHASE LINE AND NEUTRAL CONNECTIONS

The single-phase connection is shown in Figure 4. Do not exceed a nominal voltage of 240 V rms (line to neutral) in this configuration.

EVALUATION BOARD SCHEMATIC

500-98931

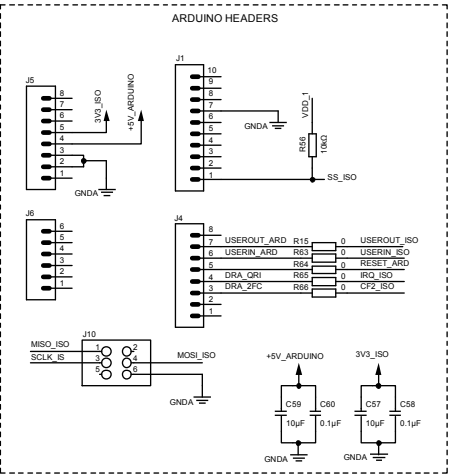
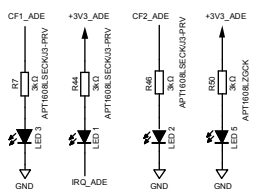
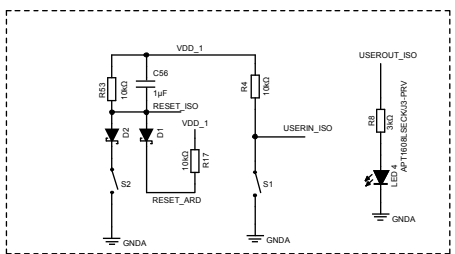
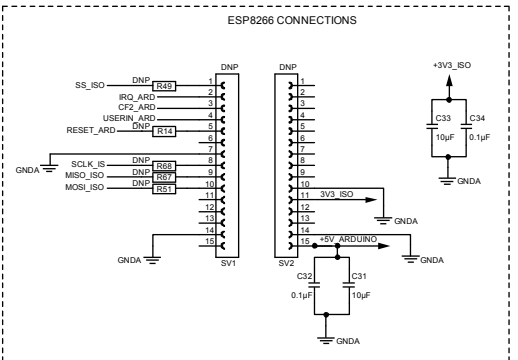
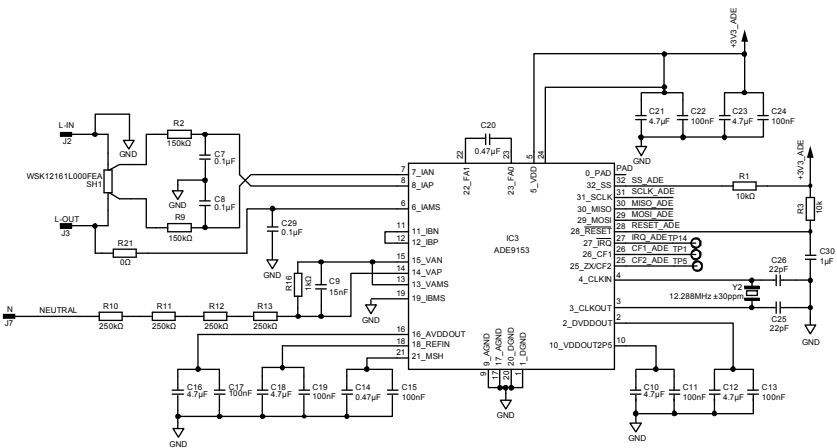
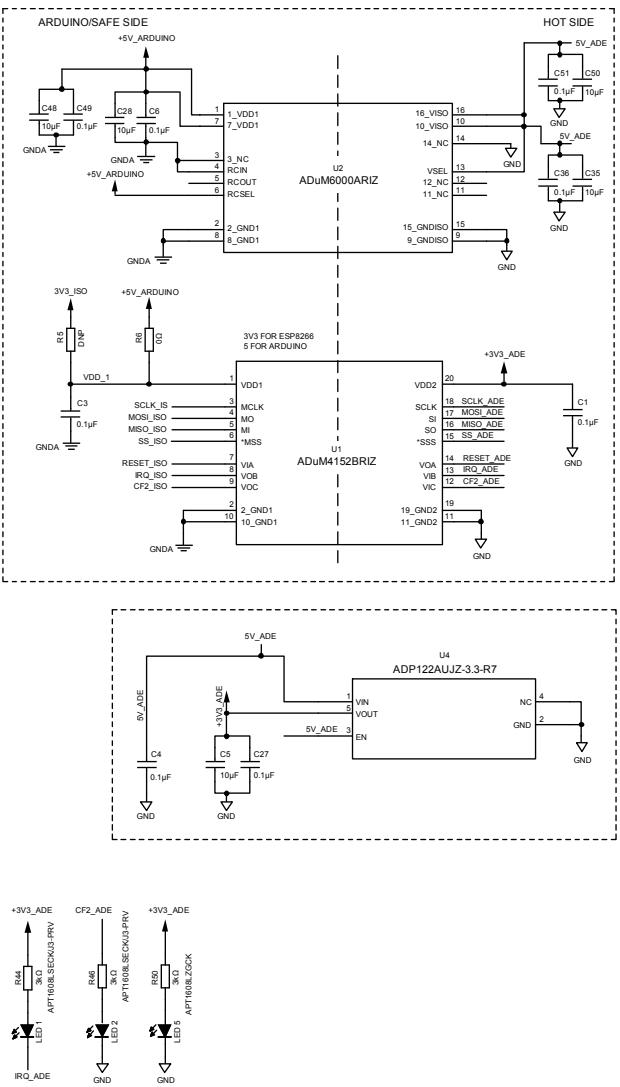

Figure 4. EV-ADE9153ASHIELDZ Schematic

## NOTES

**ESD Caution**

**ESD (electrostatic discharge) sensitive device.** Charged devices and circuit boards can discharge without detection. Although this product features patented or proprietary protection circuitry, damage may occur on devices subjected to high energy ESD. Therefore, proper ESD precautions should be taken to avoid performance degradation or loss of functionality.

**Legal Terms and Conditions**

By using the evaluation board discussed herein (together with any tools, components documentation or support materials, the "Evaluation Board"), you are agreeing to be bound by the terms and conditions set forth below ("Agreement") unless you have purchased the Evaluation Board, in which case the Analog Devices Standard Terms and Conditions of Sale shall govern. Do not use the Evaluation Board until you have read and agreed to the Agreement. Your use of the Evaluation Board shall signify your acceptance of the Agreement. This Agreement is made by and between you ("Customer") and Analog Devices, Inc. ("ADI"), with its principal place of business at One Technology Way, Norwood, MA 02062, USA. Subject to the terms and conditions of the Agreement, ADI hereby grants to Customer a free, limited, personal, temporary, non-exclusive, non-sublicensable, non-transferable license to use the Evaluation Board FOR EVALUATION PURPOSES ONLY. Customer understands and agrees that the Evaluation Board is provided for the sole and exclusive purpose referenced above, and agrees not to use the Evaluation Board for any other purpose. Furthermore, the license granted is expressly made subject to the following additional limitations: Customer shall not (i) rent, lease, display, sell, transfer, assign, sublicense, or distribute the Evaluation Board; and (ii) permit any Third Party to access the Evaluation Board. As used herein, the term "Third Party" includes any entity other than ADI, Customer, their employees, affiliates and in-house consultants. The Evaluation Board is NOT sold to Customer; all rights not expressly granted herein, including ownership of the Evaluation Board, are reserved by ADI. CONFIDENTIALITY. This Agreement and the Evaluation Board shall all be considered the confidential and proprietary information of ADI. Customer may not disclose or transfer any portion of the Evaluation Board to any other party for any reason. Upon discontinuation of use of the Evaluation Board or termination of this Agreement, Customer agrees to promptly return the Evaluation Board to ADI. ADDITIONAL RESTRICTIONS. Customer may not disassemble, decompile or reverse engineer chips on the Evaluation Board. Customer shall inform ADI of any occurred damages or any modifications or alterations it makes to the Evaluation Board, including but not limited to soldering or any other activity that affects the material content of the Evaluation Board. Modifications to the Evaluation Board must comply with applicable law, including but not limited to the RoHS Directive. TERMINATION. ADI may terminate this Agreement at any time upon giving written notice to Customer. Customer agrees to return to ADI the Evaluation Board at that time. LIMITATION OF LIABILITY. THE EVALUATION BOARD PROVIDED HEREUNDER IS PROVIDED "AS IS" AND ADI MAKES NO WARRANTIES OR REPRESENTATIONS OF ANY KIND WITH RESPECT TO IT. ADI SPECIFICALLY DISCLAIMS ANY REPRESENTATIONS, ENDORSEMENTS, GUARANTEES, OR WARRANTIES, EXPRESS OR IMPLIED, RELATED TO THE EVALUATION BOARD INCLUDING, BUT NOT LIMITED TO, THE IMPLIED WARRANTY OF MERCHANTABILITY, TITLE, FITNESS FOR A PARTICULAR PURPOSE OR NON-INFRINGEMENT OF INTELLECTUAL PROPERTY RIGHTS. IN NO EVENT WILL ADI AND ITS LICENSORS BE LIABLE FOR ANY INCIDENTAL, SPECIAL, INDIRECT, OR CONSEQUENTIAL DAMAGES RESULTING FROM CUSTOMER'S POSSESSION OR USE OF THE EVALUATION BOARD, INCLUDING BUT NOT LIMITED TO LOST PROFITS, DELAY COSTS, LABOR COSTS OR LOSS OF GOODWILL. ADI'S TOTAL LIABILITY FROM ANY AND ALL CAUSES SHALL BE LIMITED TO THE AMOUNT OF ONE HUNDRED US DOLLARS (\$100.00). EXPORT. Customer agrees that it will not directly or indirectly export the Evaluation Board to another country, and that it will comply with all applicable United States federal laws and regulations relating to exports. GOVERNING LAW. This Agreement shall be governed by and construed in accordance with the substantive laws of the Commonwealth of Massachusetts (excluding conflict of law rules). Any legal action regarding this Agreement will be heard in the state or federal courts having jurisdiction in Suffolk County, Massachusetts, and Customer hereby submits to the personal jurisdiction and venue of such courts. The United Nations Convention on Contracts for the International Sale of Goods shall not apply to this Agreement and is expressly disclaimed.