



Chipsmall Limited consists of a professional team with an average of over 10 year of expertise in the distribution of electronic components. Based in Hongkong, we have already established firm and mutual-benefit business relationships with customers from,Europe,America and south Asia,supplying obsolete and hard-to-find components to meet their specific needs.

With the principle of "Quality Parts,Customers Priority,Honest Operation,and Considerate Service",our business mainly focus on the distribution of electronic components. Line cards we deal with include Microchip,ALPS,ROHM,Xilinx,Pulse,ON,Everlight and Freescale. Main products comprise IC,Modules,Potentiometer,IC Socket,Relay,Connector.Our parts cover such applications as commercial,industrial, and automotives areas.

We are looking forward to setting up business relationship with you and hope to provide you with the best service and solution. Let us make a better world for our industry!



Contact us

Tel: +86-755-8981 8866 Fax: +86-755-8427 6832

Email & Skype: info@chipsmall.com Web: www.chipsmall.com

Address: A1208, Overseas Decoration Building, #122 Zhenhua RD., Futian, Shenzhen, China



KILOVAC EV200 Series Contactor With 1 Form X (SPST-NO) Contacts Rated 500+ Amps, 12-900 Vdc

Product Facts

- Designed to be the smallest, lightest weight, lowest cost sealed contactor in the industry with its current rating (500+A carry, 2000A interrupt at 320VDC)
- Built-in coil economizer — only 1.7W hold power @ 12VDC and it limits back EMF to 0V. Models requiring external economizer also available
- Optional auxiliary contact for easy monitoring of power contact position
- Hermetically sealed — intrinsically safe, operates in explosive/harsh environments with no oxidation or contamination of coil or contacts, during long periods of non-operation
- Versatile coil/power connections
- UL Recognized for the U.S. and Canada (File E208033) All contact ratings & coil versions may not be UL Recognized
- CE marked for EC applications
- AIAG QS9000 designed, built and approved
- RoHS versions available



EV200 Series Contactor (CZONKA Relay, Type III)

Coil Operating Voltage (Valid Over Temperature Range)			
Voltage (Will Operate)	9-36VDC	32-95VDC	48-95VDC
Voltage (Max.)	36VDC	95VDC	95VDC
Pickup (Close) Voltage Max.	9VDC	32VDC	48VDC
Hold Voltage (Min.)	7.5VDC	22VDC	34VDC
Dropout (Open) Voltage (Min.)	6VDC	18VDC	27VDC
Inrush Current (Max.)	3.8A	1.3A	0.7A
Holding Current (Avg.)	0.13A@12V, 0.07A@24V	0.03A@48V	0.02A@72V
Inrush Time (Max.)	130ms	130ms	130ms

Ordering Information

Typical Part Number ►

EV200 A A A N A

Series: _____
EV200 = 500+ Amp, 12-900VDC Contactor

Contact Form: _____
A = Normally Open
H = Normally Open with NO Aux. Contacts
G = Normally Open with NC Aux. Contacts

Coil Voltage: _____
A = 9-36VDC (1 = requires external coil economizer)
D = 32-95VDC (2 = requires external coil economizer)
J = 48-95VDC (3 = requires external coil economizer)
R = 28VDC with Mechanical Economizer

Coil Wire Length: _____
A = 15.3 in (390 mm)

Coil Terminal Connector: _____
N = None
C = Molex Mini-fit Jr, 2 Skt, Female 18-24,
P/N 39-01-2020 & 39-00-0060 +red is pin 1
(A length only)

Mounting & Power Terminals: _____
A = Bottom Mount & Male 10mm x M8 Terminals

Performance Data

Contact Arrangement, Power Contacts — 1 Form A (SPST-NO)

Rated Operating Voltage — 12 - 900 VDC

Continuous (Carry) Current, Typical — 500 A @ 85°C, 400 mcm conductors

Consult Factory for required conductors for higher (500+ A) currents

Make/Break Current at Various Voltages ¹ — See graph next page

Break Current at 320VDC ¹ — 2,000 A, 1 cycle ³

Contact Resistance, Typ. (@200A) — 0.2 mohms

Load Life — See graph next page

Mechanical Life — 1 million cycles

Contact Arrangement, Auxiliary Contacts — 1 Form A (SPST-NO)

Aux. Contact Current, Max. — 2A @ 30VDC / 3A @ 125VAC

Aux. Contact Current, Min. — 100mA @ 8V

Aux. Contact Resistance, Max. — 0.417 ohms @ 30VDC / .150 ohms @ 125VAC

Operate Time @ 25°C — Close (includes bounce), Typ. — 15 ms
Bounce (after close only), Max. — 7 ms
Release (includes arcing), Max @ 2000A — 12 ms

Dielectric Withstanding Voltage — 2,200 Vrms @ sea level (leakage <1mA)

Insulation Resistance @ 500VDC — 100 megohms ²

Shock, 11ms 1/2 Sine, Peak, Operating — 20 G

Vibration, Sine, 80-2000Hz., Peak — 20 G

Operating Ambient Temperature — -40°C to +85°C

Weight, Nominal — .95 lb. (.43 kg)

Notes:

¹ Main power contacts

² 50 at end of life

³ Does not meet dielectric & IR after test, 1700 amp for unit with Aux. Contacts

For factory-direct application assistance, dial 800-253-4560, ext. 2055, or 805-220-2055.

KILOVAC EV200 Series (CZONKA Relay, Type III) (Continued)

Outline Dimensions

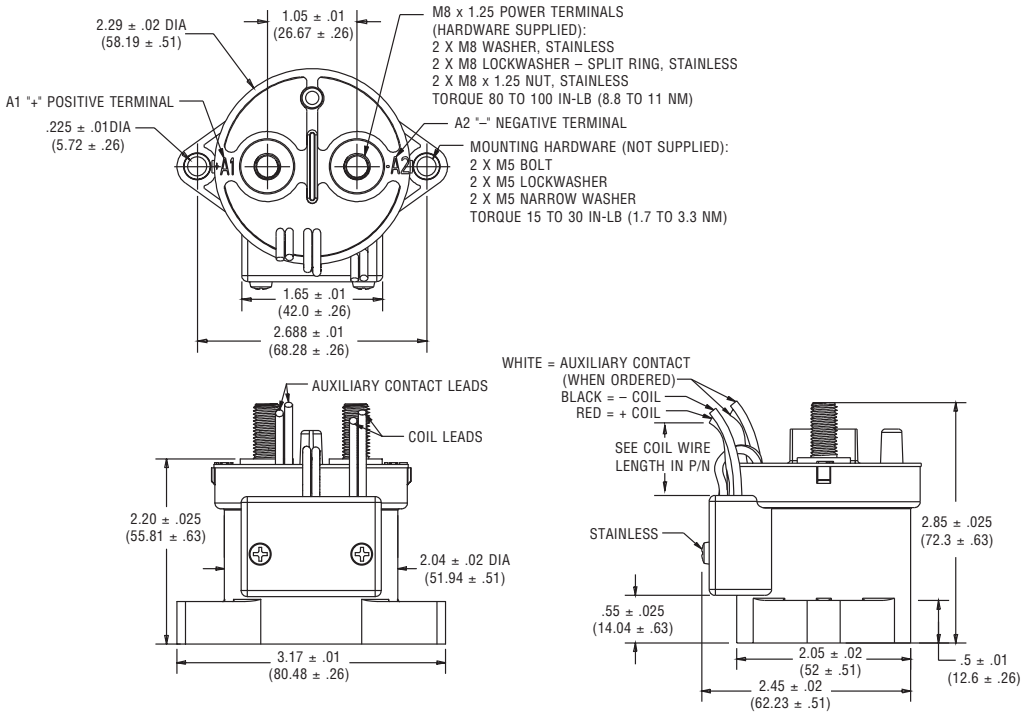

Estimated Make & Break Power Switching Ratings

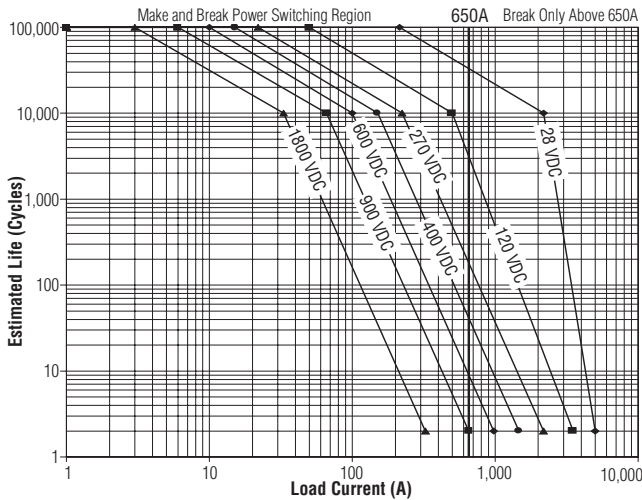

- NOTES:**
- 1) For resistive loads with 300µH maximum inductance. Consult factory for inductive loads.
 - 2) Estimates based on extrapolated data. User is encouraged to confirm performance in application.
 - 3) End of life when dielectric strength between terminals falls below 50 megohms @ 500VDC.
 - 4) The maximum make current is 650A to avoid contact welding.

EV200 Capacitive Make Test Curves for Pre-Charged Motor Controller

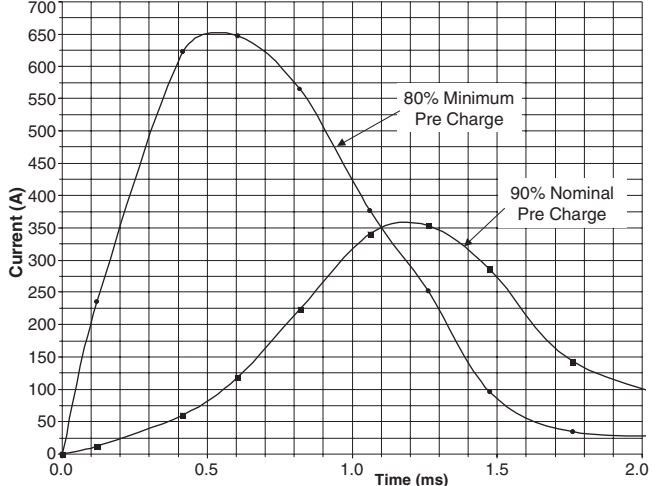

For factory-direct application assistance, dial 800-253-4560, ext. 2055, or 805-220-2055.