



Chipsmall Limited consists of a professional team with an average of over 10 year of expertise in the distribution of electronic components. Based in Hongkong, we have already established firm and mutual-benefit business relationships with customers from,Europe,America and south Asia,supplying obsolete and hard-to-find components to meet their specific needs.

With the principle of “Quality Parts,Customers Priority,Honest Operation,and Considerate Service”,our business mainly focus on the distribution of electronic components. Line cards we deal with include Microchip,ALPS,ROHM,Xilinx,Pulse,ON,Everlight and Freescale. Main products comprise IC,Modules,Potentiometer,IC Socket,Relay,Connector.Our parts cover such applications as commercial,industrial, and automotives areas.

We are looking forward to setting up business relationship with you and hope to provide you with the best service and solution. Let us make a better world for our industry!



## Contact us

Tel: +86-755-8981 8866 Fax: +86-755-8427 6832

Email & Skype: info@chipsmall.com Web: www.chipsmall.com

Address: A1208, Overseas Decoration Building, #122 Zhenhua RD., Futian, Shenzhen, China



## Features

- Single chip for driving high/low side MOSFETs / IGBTs
- High to low side isolation of 600V
- Common-mode dv/dt immunity of greater than 50V/nanosecond
- Undervoltage lockout
- Optimized power circuit layout
- High side bootstrap supply
- Sockets for freewheeling fast recovery diodes (FREDS)
- Flexibility of power level utilization
- 5V compatible HCMOS input logic with hysteresis
- Protection from cross conduction of the half bridge
- Simple, fast and low cost means of evaluation and design
- Option for using IXDP630 with RC oscillator or IXDP631 with crystal oscillator for improved dead time accuracy.
- Three phase operation with the ability to attach additional slave driver boards.

## Introduction

The EV6R11 KIT implements a single power phase-leg circuit on a double-sided PCB, using the ISOSMART™ HALF BRIDGE DRIVER CHIPSET - IX6R11 and IXDP630 dead time generator. This evaluation board includes an assembled and tested PCB with two power devices. Just follow the instructions in this document and connect the board to the load and power.

Any power circuit is layout sensitive. The layout of this PCB is a proven, working layout. The designer is invited to duplicate this layout in his system, following the evaluation of the driver chipset.

Most systems vary in their power level requirements and therefore the power devices used. Due to this fact and fluctuations in availability of power devices, the kit will not always include the same power devices. The designer is encouraged to use the power devices that are required for his system. The devices that are enclosed serve only for initial evaluation.

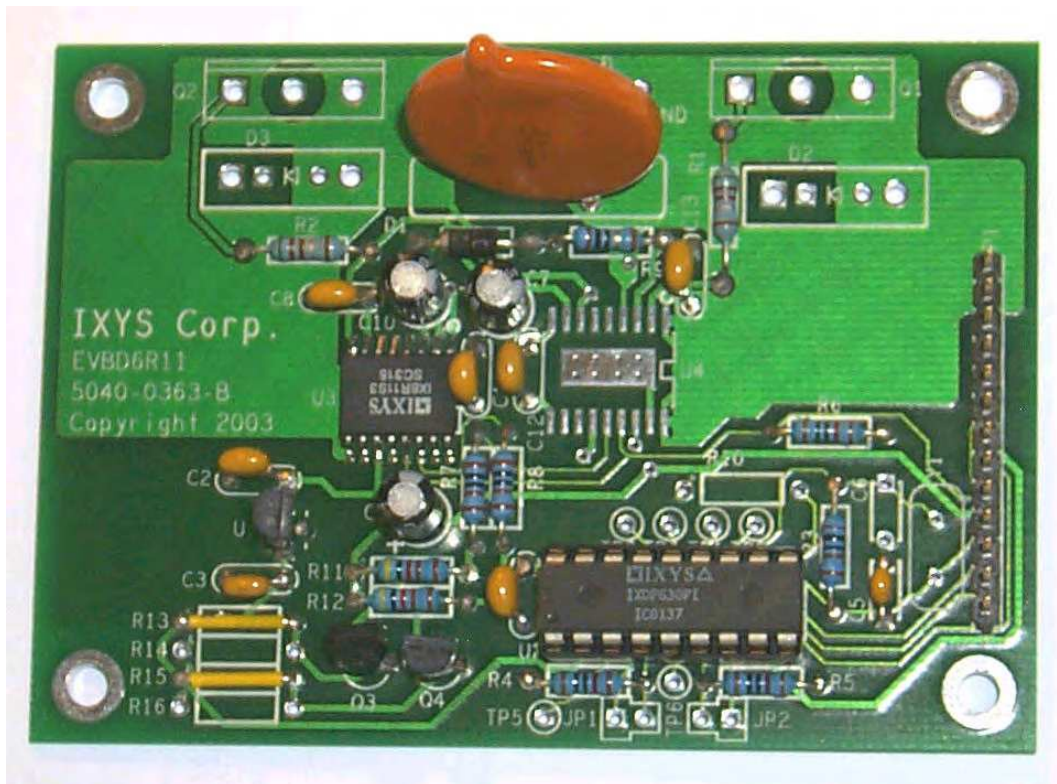

Figure 1: EV6R11 Assembled PCB With S3 Package

## Schematic Diagram:

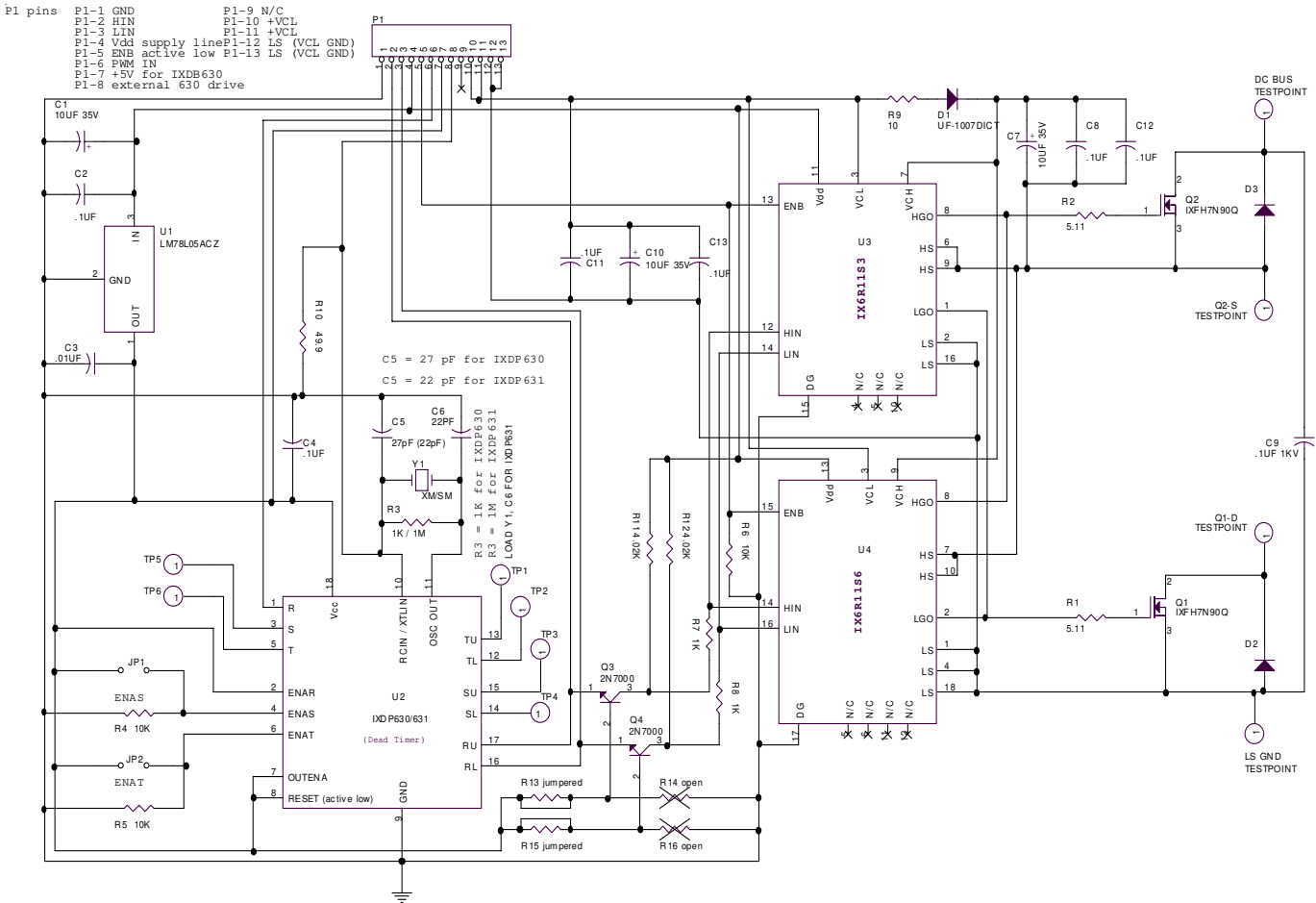

Figure 3: EV6R11 PCB Schematic

## Schematic Notes:

This is a demonstration PCB and has been designed for flexibility and ease of use. The schematic shows all options but does not mean the PCB is configured as such when ordered. The PCB will be loaded with either the IX6R11S3 16 pin SOIC package (U3) OR the IX6R11S6 18 pin SOIC package with heat sink tab (U4). The free-wheeling diodes, D2 and D3, are also not included but can be installed if IGBTs are used.

## Ordering:

EV6R11S3	PCB with IX6R11S3 16 pin SOIC IC package
EV6R11S6	PCB with IX6R11S6 18 pin SOIC IC package with heat tab

## ASSEMBLY:

Figure 3 is a complete schematic diagram of the design kit. This schematic indicates an application using MOSFETs. When IGBTs are used, freewheeling diodes (D2&D3) are typically added.

To operate the PCB, simply solder the included MOSFET power devices and C9 or install devices specific to your application. Note gate drain source pin orientation of power devices when installing on the PCB. C9 has not been installed due to its high profile and possible lead damage.

## NOTES:

**a)** The ICs and Power devices are static sensitive and require special handling.

**b)** Use any power device that is suitable for your application. The PCB was designed to accept devices with TO-247 or TO-264 packages. Two IXYS power devices are included in the kit. D2 and D3 are required only if Q1 and Q2 are IGBTs, and thus are not included in the kit. (A recommendation for D2 & D3 is in the Bill of Materials).

**c)** Use any convenient method of interconnection at LS\_GND, Q1-D, Q2-S, DC\_BUS. The hole spacing is 5.08mm and will fit most common terminal blocks. (A recommendation for a connector that the PCB will accept is in the Bill of Materials and is available from Digi-Key among other sources).

**d)** For half bridge applications, insert a jumper between Q1-D and Q2-S.

**e)** The gate resistors, R1 and R2, will depend on the power device size that is used. 5.11 Ohm resistors are installed and should work for most applications.

**f)** IXDP630 dead time is provided by timing components R3 and C5 and is fixed at roughly 1 microsecond. See the IXDP630 data sheet for calculation and modification of the dead time value. It must also be noted that dead time starts to impact drive signals as drive frequency goes

up. Jitter is then produced as drive signal 'On' time overlaps into dead time. A practical limit in values are soon reached with timing components R3 and C5 as they are adjusted to compensate for the reduced period in drive frequency. It is possible to 'overdrive' the IXDP630 with an external clock signal applied to pin 10 to reduce dead time even further than what is possible with R3 and C5. To do this, remove R3, C5 from the board and install a 50 Ohm load resistor at position R10. Solder pads have been provided at R10 to solder the ends of a coax cable directly to the board. The IXDP630 can be driven in excess of 50MHz.

**g)** The IXDP630 dead time generator is a 5V HCMOS device. The addition of the IXDP630 on the evaluation board is in part for convenience in providing dual complementary drive signals. The IXDP631 is a performance extension of the IXDP630 and can be added as desired by the user. However there is no part number available for a IXDP631 loaded evaluation board and the user must request IXDP631 samples separately. Please note that threshold levels must be observed when selecting the front end logic Vdd supply voltage. To increase threshold level flexibility, this PCB incorporates a level translation circuit with Q3 and Q4. As configured, a three terminal +5V regulator, U1, supplies power to the IXDP630 and translator circuit which implies that Vdd should be greater than 8V to prevent regulator drop-out. Please note that this is only one way to configure the board and was chosen to provide a fast, easy way to get started during the design stage.

**DATA SHEETS:**

The following list provides direct web links for the IXYS devices included with this PCB. Please visit the IXYS web site at [www.ixys.com](http://www.ixys.com) for a complete overview of the entire IXYS product line.

IX6R11 Half Bridge Driver IC:  
<http://www.ixys.com/99037.pdf>

IXDP630 Digital Dead Time Generator:  
<http://www.ixys.com/98568.pdf>

IXFH 7N90Q Power MOSFETS:  
<http://www.ixys.com/98645.pdf>

**Bill of Materials**

Reference	Qty.	Description	Mfr.	Part #
U1	1	+5V regulator	National Semi.	LM78L05ACZ
U2	1	Dead time generator IC	IXYS	IXDP630
U3	1	16 pin Half Bridge Driver	IXYS	IX6R11S3
U4	1	18 pin Half bridge Driver	IXYS	IX6R11S6
D1	1	1A, 1000V high speed diode	Diodes Inc.	UF1007DICT
U2	1	18 pin socket	Assmann	A18-LC-TT
Q1, 2	2	High voltage power MOSFET	IXYS	IXFH7N90Q
Q3, 4	2	Switching MOSFET	Motorola	2N7000
R1, 2	2	5.11 ohm, 1/4 W resistors		
R4, 5, 6	3	10k ohm, 1/4 W resistors		
R3, 7, 8	3	1k ohm, 1/4 W resistors		
R9	1	10 ohm, 1/4 W resistors		
R11, 12	2	4.02k ohm 1/4 W resistors		
R13, 15	2	Insulated wire jumpers		
C1,7,10	3	10uF, 35V, aluminum electrolytic cap	Panasonic	
C2,4,8,11,12,13	6	0.1uF, 50V, ceramic cap	Panasonic	
C3	1	0.01uF, 50V, ceramic cap		
C5	1	27pF, 50V, ceramic cap	Panasonic	
C9	1	0.1uF, 1000V, ceramic cap	Sprague	10GAP10
P1	1	13 pin header connector	Berg	68000-236
<b>NOT INCLUDED:</b>				
U2	1	Crystal based dead time generator	IXYS	IXDP631
D4, D5	2	12A, 1000V fast recovery diode	IXYS	DSEI12-10A
P2	1	4 pole terminal block	Altech Corp.	AKZ250/4
R3	1	1M ohm, 1/4 W IXDP631 osc load resistor		
R10	1	50 ohm, 1/4 W load resistor		
C5, 6	2	Crystal load capacitors, 22pF 50V ceramic	Panasonic	
Y1	1	Crystal for IXDP631 operation	Pletronics	

## OPERATION:

### For performance evaluation and power system design please note the following:

**a)** The assembled board can be run with the IXDP630 removed by applying complementary 5V square waves with proper "dead time" to the input pins HIN (P1-2) and LIN (P1-3).

For standard IXDP630 operation, the values of R3 and C5 have been listed on the bill of materials. These values are for demonstration, which may not be appropriate for your application and can be changed as needed. For IXDP631 operation, load R3, C5, C6 with the recommended load components as outlined in the IXDP630/631 data sheet along with the crystal at the frequency of choice. R3 and C5 serve a dual purpose depending on which dead timer is used.

The IXDP630 is hardwired for phase 'R' operation, see 630/631 data sheet, with pins OUTENA, ENAR, and RESET tied high. PWM drive input signal for 'R' phase is applied to P1-6.

To add phases 'S' and/or 'T', enable phases with jumpers at JP1 and/or JP2 and apply PWM phase drive signals to TP5 and/or TP6 taking the respective complementary outputs from TP1 through TP4. Note that TP1-TP6 are through-hole pads that have been added to the board to serve as convenient solder and/or test points.

**b)** The IX6R11 provides a wide range of flexibility with its power supply requirements. However, threshold levels must be observed in the relationship between Vdd to HIN and LIN when selecting power supply values in the final design. Device propagation delays can also be minimized by observing relative values between supplies.

**c)** Be careful with ground connections. Avoid ground loops. In general, connect the grounds as shown in Figure 4 to minimize ground bounce effects. This is particularly important when three "High/Low side driver design kits" are connected together with a single IXDP630

to form a three phase drive system, such as that shown in Figure 5.

**d)** Before using the PCB at full power or attempting a short circuit test, make sure that a proper high voltage electrolytic capacitor is connected between DC BUS and GND as shown in Figure 4. The leads to this capacitor should be as short as possible to minimize any stray inductance.

**e)** Figure 4 shows the load terminated at point A. This point could be connected to a number of places depending on the application. For example: Connection to ground will test the high side device. Connection to DC BUS will test the low side device. It could also be connected to the center point of a capacitive divider (UPS systems).

**f)** Figure 5 shows a three phase power system implementation with a load configured in a Y (star). It could also be configured in a DELTA configuration. Please note the grounding scheme. Cut the connection between "ground plane 2" and "ground plane 4" on the components side of the PCB and solder a 10 Ohm resistor between these ground planes. The GND of each board is terminated to a single ground point.

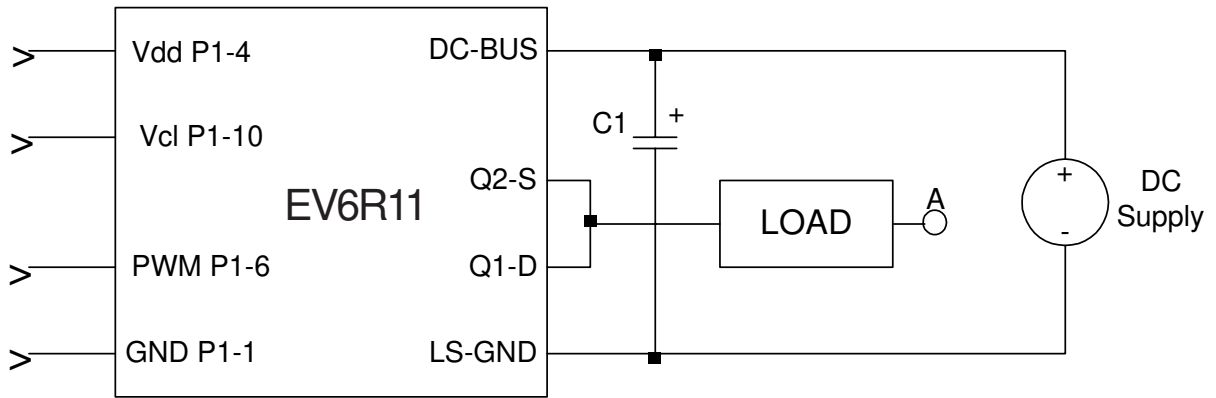

Figure 4: Evaluation Board & Load Termination

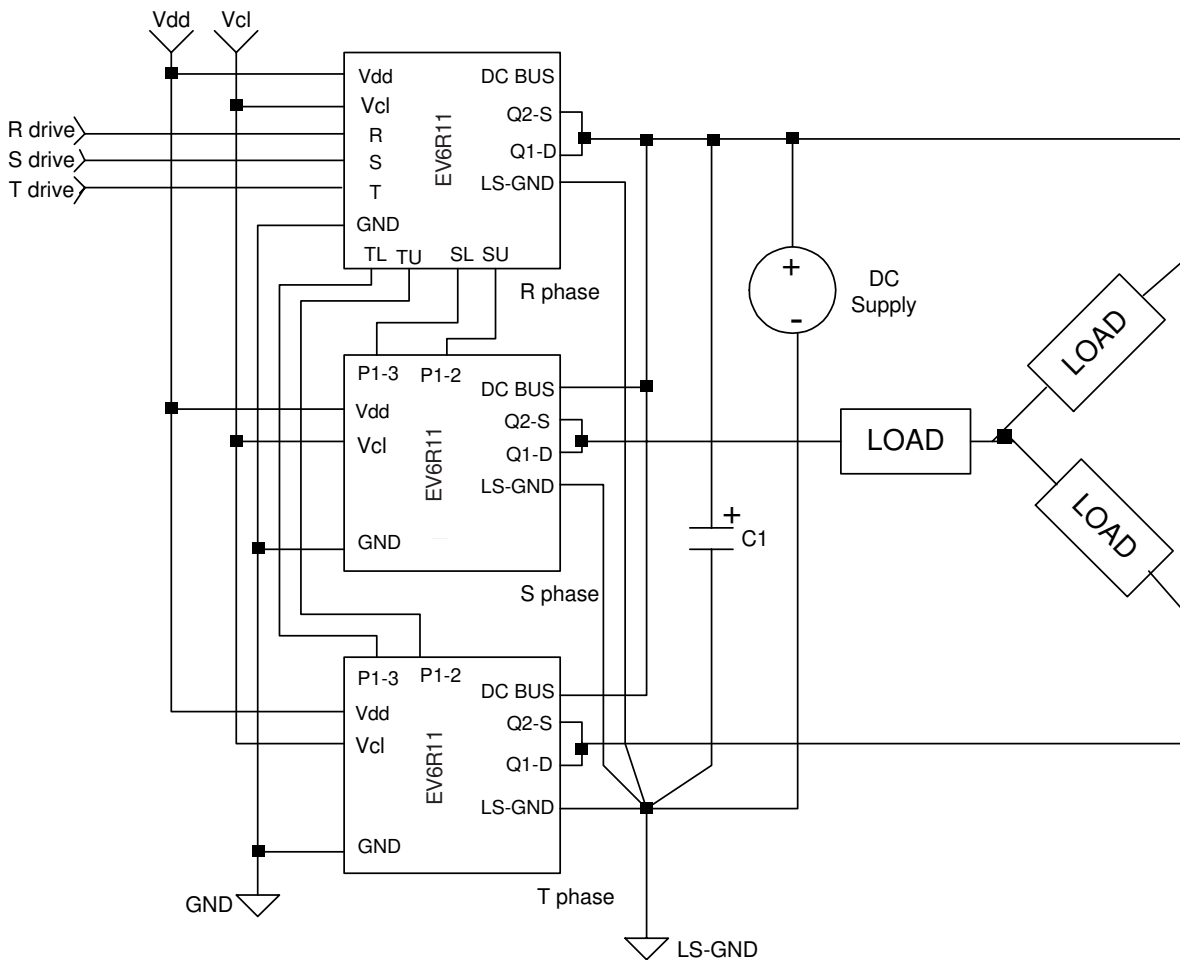

Figure 5: EV6R11 Three Phase Configuration

With the addition of High Current MOSFET Drivers on the outputs, the IX6R11's typical 6A peak output current capability can be "boosted" to drive the latest IXYS MOSFETS & IGBTs. Figure 6 shows the addition of two IXDD414's. These are CMOS high-speed MOSFET drivers that have a 14A Peak Output Drive Capability, allowing the IX6R11 to drive a pair of IXFK90N20Q 90A/200V Power MOSFETs. The 2 Ohm gate resistors shown should be Non-Inductive High Performance Film resistors such as those available from Caddock. Particular attention also needs to be paid to Supply By-passing, Grounding, and minimizing the Output Lead Inductance when designing such a high power circuit layout.

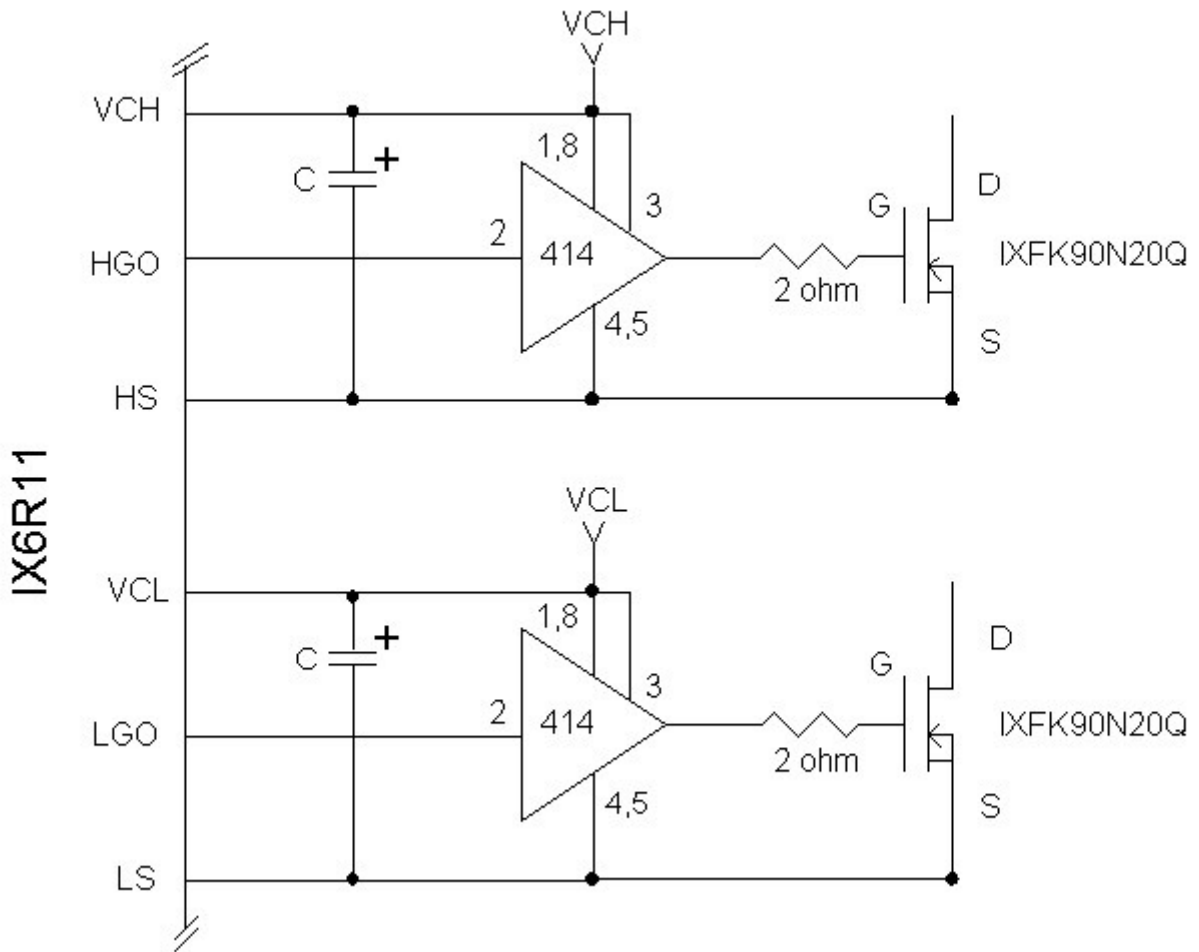

Figure 6: Boosting the IX6R11 outputs for larger MOSFETs.