



Chipsmall Limited consists of a professional team with an average of over 10 year of expertise in the distribution of electronic components. Based in Hongkong, we have already established firm and mutual-benefit business relationships with customers from,Europe,America and south Asia,supplying obsolete and hard-to-find components to meet their specific needs.

With the principle of "Quality Parts,Customers Priority,Honest Operation,and Considerate Service",our business mainly focus on the distribution of electronic components. Line cards we deal with include Microchip,ALPS,ROHM,Xilinx,Pulse,ON,Everlight and Freescale. Main products comprise IC,Modules,Potentiometer,IC Socket,Relay,Connector.Our parts cover such applications as commercial,industrial, and automotives areas.

We are looking forward to setting up business relationship with you and hope to provide you with the best service and solution. Let us make a better world for our industry!



Contact us

Tel: +86-755-8981 8866 Fax: +86-755-8427 6832

Email & Skype: info@chipsmall.com Web: www.chipsmall.com

Address: A1208, Overseas Decoration Building, #122 Zhenhua RD., Futian, Shenzhen, China



FEATURES

Full-featured evaluation board for the AD5764R

On-board reference

On-board ADC for temperature readback

Link options

Direct hook-up to USB port of PC

PC software for control

EVALUATION BOARD DESCRIPTION

The EVAL-AD5764R is a full-featured evaluation board designed to allow the user to easily evaluate all features of the [AD5764R](#) quad-channel, 16-bit DAC. All of the AD5764R pins are accessible at on-board connectors for external connection. The board can be controlled by two means: via the on-board connectors or via the USB port of a Windows®-based PC using the AD5764R evaluation software. The default setup is for control via the USB port.

DEVICE DESCRIPTION

The AD5764R has a nominal output voltage span of ± 10 V derived from an internal 10 ppm/°C reference voltage of +5 V. The part also includes a 3-wire serial interface that is compatible with SPI, QSPI™, MICROWIRE™, and DSP interface standards. Data is written to the AD5764R in a 24-bit word format, and a data output pin (SDO) is also offered for daisy-chaining or readback.

The DAC outputs are updated upon reception of new data into the DAC registers. All outputs can be simultaneously updated by taking the $\overline{\text{LDAC}}$ input low.

Each channel has a programmable gain and offset adjust register. Each DAC output is buffered on chip.

Complete specifications for the AD5764R are available in the AD5764R data sheet available from Analog Devices, Inc., and should be consulted in conjunction with this data sheet when using the evaluation board.

FUNCTIONAL BLOCK DIAGRAM

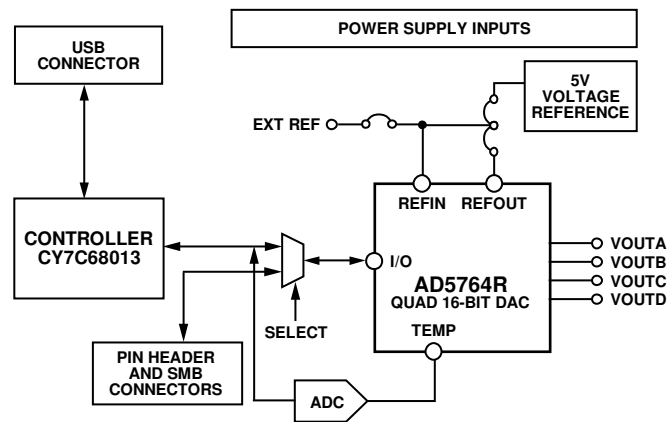

Figure 1.

Rev. 0

Evaluation boards are only intended for device evaluation and not for production purposes. Evaluation boards are supplied "as is" and without warranties of any kind, express, implied, or statutory including, but not limited to, any implied warranty of merchantability or fitness for a particular purpose. No license is granted by implication or otherwise under any patents or other intellectual property by application or use of evaluation boards. Information furnished by Analog Devices is believed to be accurate and reliable. However, no responsibility is assumed by Analog Devices for its use, nor for any infringements of patents or other rights of third parties that may result from its use. Analog Devices reserves the right to change devices or specifications at any time without notice. Trademarks and registered trademarks are the property of their respective owners. Evaluation boards are not authorized to be used in life support devices or systems.

TABLE OF CONTENTS

Features	1	Evaluation Board Software.....	5
Evaluation Board Description.....	1	Software Installation	5
Device Description	1	Software Operation	5
Functional Block Diagram	1	Evaluation Board Schematics and Artwork.....	7
Revision History	2	Ordering Information.....	11
Evaluation Board Hardware	3	Bill of Materials.....	11
Power Supplies	3	Ordering Guide	11
Link Options	3	ESD Caution.....	11

REVISION HISTORY

4/09—Revision 0: Initial Version

EVALUATION BOARD HARDWARE

POWER SUPPLIES

The following external supplies must be provided:

- 5 V between the 5 V and DGND inputs for the digital supply of the AD5764R and digital circuitry. Alternatively, place Link 1 in Position A to power the digital circuitry from the USB port (default).
- 11.4 V to 16.5 V between the AV_{DD} and AGND inputs for the positive analog supply of the AD5764R.
- -11.4 V to -16.5 V between the AV_{SS} and AGND inputs for the negative analog supply of the AD5764R.

Both AGND and DGND inputs are provided on the board. The AGND and DGND planes are connected at one location close to the AD5764R. It is recommended not to connect AGND and DGND elsewhere in the system to avoid ground loop problems.

Each supply is decoupled to the relevant ground plane with 10 μ F and 0.1 μ F capacitors. Each device supply pin is again decoupled with a 10 μ F and 0.1 μ F capacitor pair to the relevant ground plane.

LINK OPTIONS

The position of Link 11 configures the board for either PC control via the USB port (default setup) or for control by an external source via J21 or the SMB connectors. The link options on the evaluation board should be set for the required operating setup before using the board. The functions of the link options are described in Table 4.

Default Link Option Setup

The default setup is for control by the PC via the USB port. The default link options are listed in Table 1.

Table 1. Link and Switch Options for PC Control

Link No.	Option
LK1	A
LK2	C
LK3	Inserted
LK4	B
LK5	A and B inserted
LK6	Removed
LK7	A
LK8	A
LK9	A
LK10	Removed
LK11	B
LK12	Inserted
LK13	Inserted
LK14	Inserted

Connector J21 Pin Descriptions

The pin configuration for J21 is shown in Table 2. Descriptions for the J21 pins are in Table 3.

Table 2. Connector J21¹ Pin Configuration

13	11	9	7	5	3	1
14	12	10	8	6	4	2

¹ LK11 must be in Position A to enable the use of J21.

Table 3. Connector J21 Pin Descriptions

Pin No.	Description
1	SYNC
2	SCLK
3	SDIN
4	SDO
5	LDAC
6	CLR
7	D0
8	D1
9	RSTOUT
10	RSTIN
11	BIN/2sCOMP
12	DGND
13	DGND
14	DGND

EVAL-AD5764R

Table 4. Link Options

Link No.	Description
LK1	This link selects the +5 V power supply source for the digital circuitry. Position A selects the USB port as the +5 V digital circuitry power supply source. Position B selects J2 as the +5 V digital circuitry power supply source.
LK2	This link selects the value of the short-circuit protection for the four DAC outputs. Position A selects a resistor value of 120 k Ω , selecting a current value of 500 μ A. Position B selects a resistor value of 24 k Ω , selecting a current value of 2.5 mA. Position C selects a resistor value of 6.2 k Ω , selecting a current value of 10 mA. Position D selects a user-defined resistor value, selecting a user-defined current value.
LK3	This link connects AGNDA to 0 V.
LK4	This link selects the reference source. Position A selects the internal reference as the reference source. Position B selects the on-board 5 V reference as the reference source.
LK5	This link connects the on-board reference source to REFAB and REFC. If sourcing REFAB external to the board via J3, Position B should not be inserted. If sourcing REFC external to the board via J4, Position A should not be inserted. Position A connects REFC to the on-board reference source. Position B connects REFAB to the on-board reference source.
LK6	This link connects the TEMP pin to the input of the on-board ADC. When inserted, the voltage at the TEMP pin can be read back to the PC. When removed, the voltage at the TEMP pin is disconnected from the on-board ADC input.
LK7	This link selects the digital supply voltage value for the AD5764R and ADG774BRQ (U7, U8, and U9). Position A selects 3.3 V as the supply value. Position B selects 5 V as the supply value.
LK8	This link selects the state of the LDAC pin. Position A allows the LDAC pin to be driven from either the PC or via J21 or the SMB connectors. Position B connects the LDAC pin to DGND.
LK9	This link selects the state of the BIN/2sCOMP pin when external control is selected via LK11. Position A connects the BIN/2sCOMP pin to DV _{CC} , selecting straight binary as the data coding format. Position B connects the BIN/2sCOMP pin to DGND, selecting twos complement as the data coding format. Removing LK9 allows the BIN/2sCOMP pin to be driven from J21.
LK10	This link selects the state of the CLR pin when external control is selected via LK11. When inserted, the CLR pin is connected to DGND and the four DAC outputs are cleared. When removed, the CLR pin is pulled to DV _{CC} through a 10 k Ω resistor.
LK11	This link selects whether the AD5764R evaluation board is controlled by the PC via the USB port or by an external source via J21 or the SMB connectors. Position A selects the evaluation board to be controlled by an external source via J21 or the SMB connectors. Position B selects the evaluation board to be controlled by the PC via the USB port.
LK12	This link connects AGNDB to 0 V.
LK13	This link connects AGNDC to 0 V.
LK14	This link connects AGNDD to 0 V.

EVALUATION BOARD SOFTWARE

SOFTWARE INSTALLATION

The AD5764R evaluation kit includes self-installing software on a CD. The software is compatible with Windows 2000/NT/XP. If the setup file does not run automatically, you can run **setup.exe** directly from the CD.

Install the evaluation software before connecting the evaluation board to the USB port of the PC to ensure that the evaluation board is correctly recognized when connected to the PC.

After the installation from the CD is complete, power up the AD5764R evaluation board as described in the Power Supplies section.

1. Connect the AD5764R evaluation board to the USB port of your PC using the supplied cable.
2. When the evaluation board is detected, proceed through any dialog boxes that appear. This finishes the installation.

SOFTWARE OPERATION

To launch the software, complete the following steps:

1. From the **Start** menu, select **Analog Devices**; then select **AD5764R**.
2. Click **AD5764R Evaluation Software**. The main window of the software is displayed (see Figure 2).

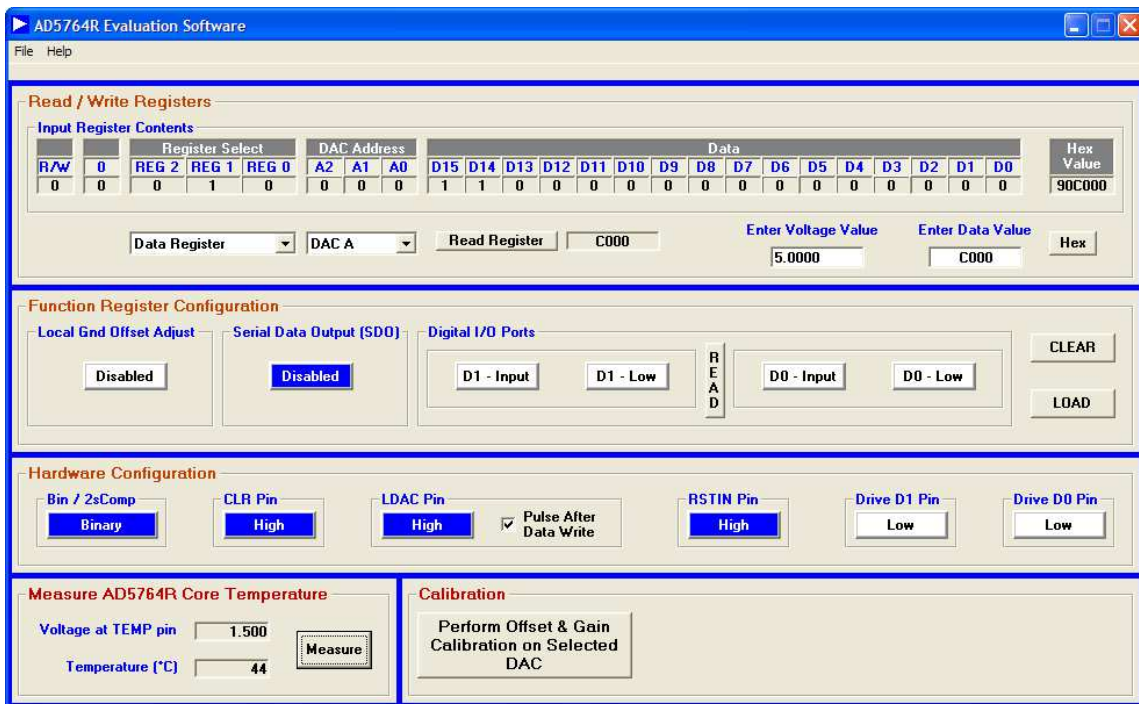

Figure 2. Main Window

08161-002

EVAL-AD5764R

The main window is divided into five sections: **Read/Write Registers**, **Function Register Configuration**, **Hardware Configuration**, **Measure AD5764R Core Temperature**, and **Calibration**.

Read/Write Registers

In the **Read/Write Registers** section, you can write a value to—or read a value from—any **AD5764R** register. The logic values of all bits in the input register are also displayed. Access to the registers is via two drop-down boxes. In the first box, you can select a register, and in the second box, you can select one of the four DAC channels. In the case of the function register, the second drop-down box is not available. Depending on the register selected, either another drop-down box (if a coarse gain register is selected) or a text box is displayed.

For instance, to write to the DAC A data register, do the following:

1. Select **Data Register** from the first drop-down box and **DAC A** from the second drop-down box (see Figure 2).
2. Two text boxes are displayed in which you can type a voltage value (**Enter Voltage Value** box) or a 16-bit data value (**Enter Data Value** box).
3. Click the button to the right of the text boxes to select hex or decimal format for the value.
4. Press the **Enter** key to complete the write operation.

Function Register Configuration

The **Function Register Configuration** section allows you to define the configuration of the function register, that is, to enable/disable the **Local Gnd Offset Adjust** feature, enable/disable the **Serial Data Output (SDO)** pin, and set the D0 and D1 **Digital I/O Ports** as inputs or outputs and read or set their values. The **CLEAR** button initiates a software clear operation, and the **LOAD** button initiates a software load operation. See the AD5764R data sheet for further information.

Hardware Configuration

In the **Hardware Configuration** section, you can configure the hardware setup of the AD5764R; that is, you can set the configuration of the **BIN/2sCOMP**, **CLR**, **LDAC** and **RSTIN** pins. When the D0 and D1 ports are defined as inputs, you can also drive the D0 and D1 pins high or low and read their values in the **Function Register Configuration** section.

Measure AD5764R Core Temperature

The **Measure AD5764R Core Temperature** section displays the voltage at the TEMP pin (as provided by the on-board ADC) and the related core temperature. To obtain updated measurements, click the **Measure** button.

Calibration

The **Calibration** section allows you to remove any offset or gain errors that exist on each of the DACs. The procedure to calibrate a DAC channel is as follows:

1. Select the DAC to be calibrated in the **Read/Write Registers** section.
2. In the **Calibration** section, click the **Perform Offset & Gain Calibration on Selected DAC** button. The **Calibration** section display changes as shown in Figure 3.
3. In the **Read/Write Registers** section, load 0 V to the DAC and measure the output voltage of the DAC.
4. Enter the measured value in the **Calibration** section.
5. Click **Done**. The offset error should now be reduced and the **Calibration** section should display changes as shown in Figure 4.
6. In the **Read/Write Registers** section, load zero scale to the DAC (–4.096 V, –4.201 V, or –4.311 V).
7. Measure the output voltage of the DAC and enter the measured value in the **Calibration** section.
8. Click **Done**. The gain error should now be reduced.
9. Repeat this procedure for the other three DACs.

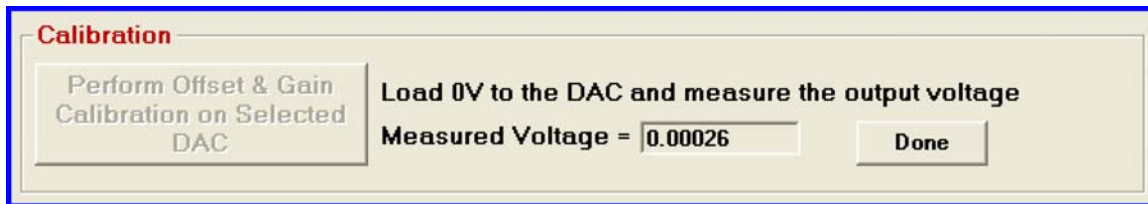

Figure 3. Calibrating for Offset Error

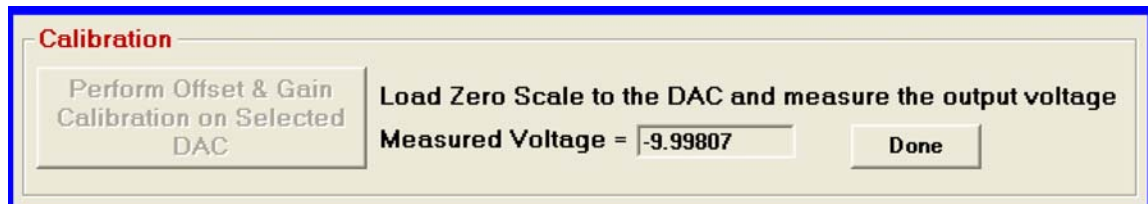

Figure 4. Calibrating for Gain Error

EVALUATION BOARD SCHEMATICS AND ARTWORK

500-19180

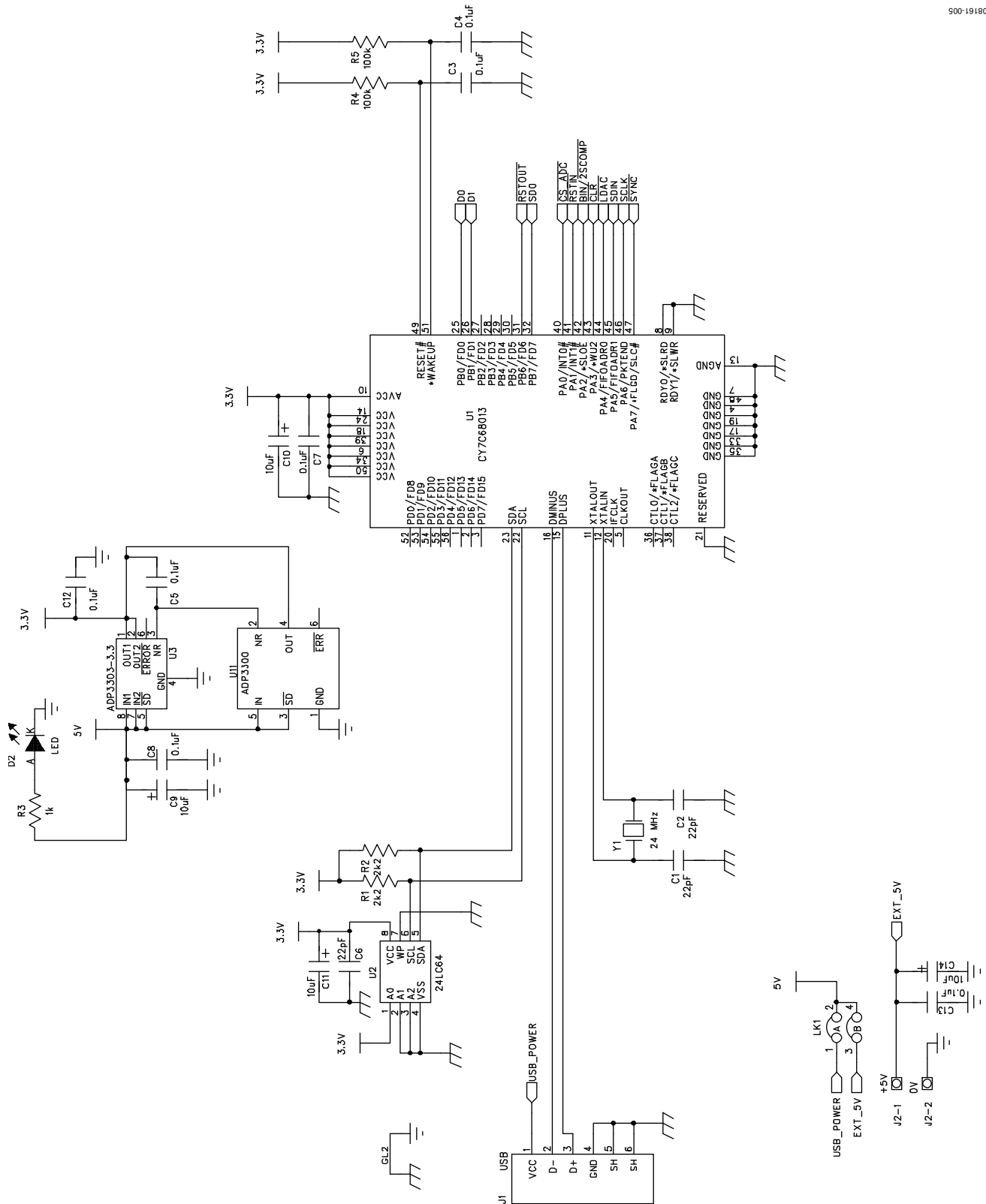

Figure 5. Schematic of Controller Circuitry

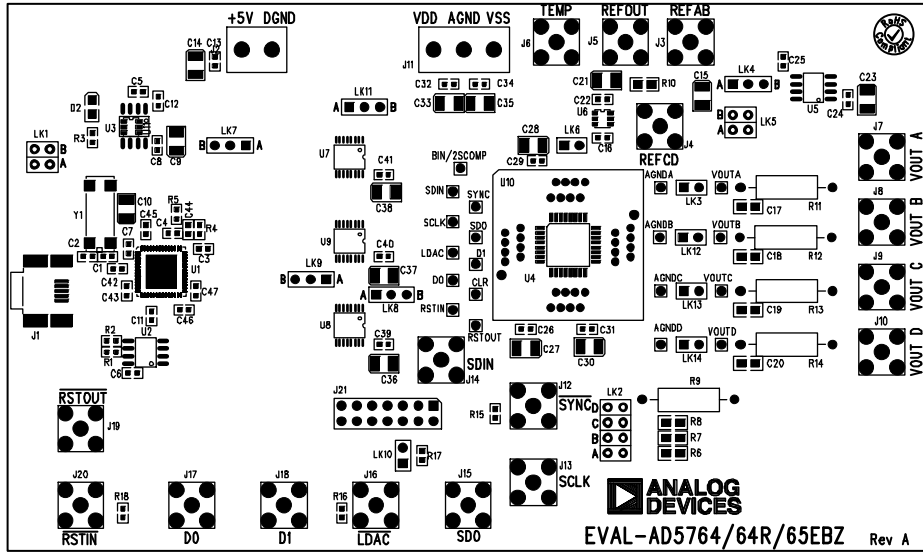

Figure 7. Component Placement

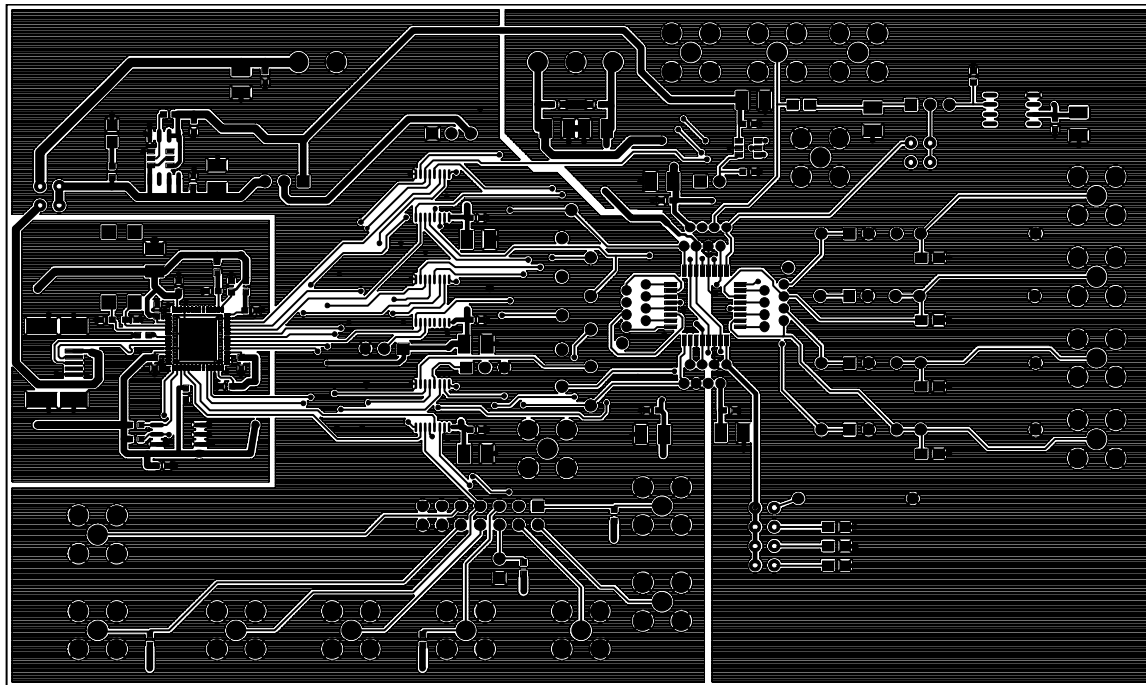
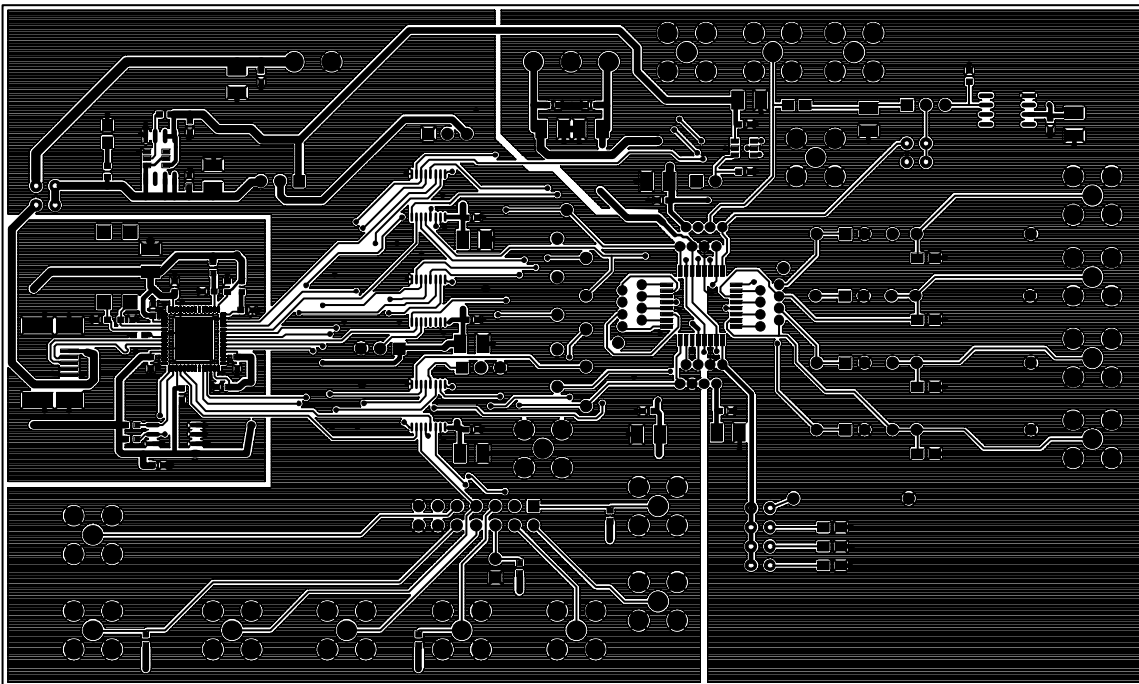

Figure 8. Solder Side PCB



610161-009

Figure 9. Component Side PCB

ORDERING INFORMATION

BILL OF MATERIALS

Table 5.

Qty	Reference Designator	Description	Supplier/Number
1	U1	CYC68013A-56LFCX	Digi-Key/428-1332-ND
1	U2	24LC64	Digi-Key/24LC64-1/SN-ND
1	U3	ADP3303ARZ-3.3	Analog Devices/ADP3303ARZ-3.3
1	U4	AD5764RCSUZ	Analog Devices/AD5764RCSUZ
1	U5	ADR02BRZ	Analog Devices/ADR02BRZ
1	U6	AD7476ARTZ	Analog Devices/AD7476ARTZ
3	U7, U8, U9	ADG774BRQ	Analog Devices/ADG774BRQ
1	U10	32-pin QFP socket	32QFP-SKT-OTQ-32-08-02
2	R1, R2	2.2 k Ω resistor, 0603 package	FEC 9330810
1	R3	1 k Ω resistor, 0603 package	FEC 9330380
2	R4, R5	100 k Ω resistor, 0603 package	FEC 9330402
1	R6	120 k Ω resistor, 0805 package	FEC 9332510
1	R7	56 k Ω resistor, 0805 package	FEC 9333380
1	R8	6.2 k Ω resistor, 0805 package	FEC 9333428
1	R10	0 Ω resistor 0805 package	FEC 9333681
4	R15, R16, R17, R18	10 k Ω resistor, 0603 package	FEC 9330399
3	C1, C2, C6	22 pF ceramic capacitor, 0603 package	FEC 722005
18	C3, C4, C5, C7, C8, C12, C13, C22, C24, C25, C26, C29, C31, C32, C34, C39, C40, C41	0.1 μ F ceramic capacitor, 0603 package	FEC 1216538
15	C9, C10, C11, C14, C15, C21, C23, C27, C28, C30, C33, C35, C36, C37, C38	10 μ F tantalum capacitor, TAJ_B package	FEC 498737
1	C16	100 pF ceramic capacitor, 0603 package	FEC 499122
2	LK1, LK5	4-pin header and shorting link	FEC 1022233 and FEC 150411
1	LK2	8-pin header and shorting link	FEC 1022233 and FEC 150411
6	LK3, LK6, LK10, LK12, LK13, LK14	2-pin header and shorting link	FEC 1022247 and FEC 150411
5	LK4, LK7, LK8, LK9, LK11	3-pin header and shorting link	FEC 1022249 and FEC 150411
1	J1	USB Receptacle B	FEC 9786490
1	J2	2-way screw terminal	FEC 151789
17	J3 to J10, J12 to J20	50 Ω SMB jack	FEC 1111349
1	J11	3-way screw terminal	FEC 151790
1	J21	32-way dil header	FEC 5217842
19	AGNDA, AGNDB, AGNDC, AGNDD, BIN/2sCOMP, CLR, D0, D1, RSTIN, LDAC, RSTOUT, SCLK, SDIN, SDO, SYNC, VOUTA, VOUTB, VOUTC, VOUTD	Test point	FEC 240333
1	D2	LED, 0805 package	FEC 5790840
1	Y1	24 MHz crystal, HC49 package	FEC 569860

ORDERING GUIDE

Model	Package Description
EVAL-AD5764REBZ ¹	AD5764R Evaluation Board

¹ Z = RoHS Compliant Part.

ESD CAUTION



ESD (electrostatic discharge) sensitive device. Charged devices and circuit boards can discharge without detection. Although this product features patented or proprietary protection circuitry, damage may occur on devices subjected to high energy ESD. Therefore, proper ESD precautions should be taken to avoid performance degradation or loss of functionality.

EVAL-AD5764R

NOTES