



Chipsmall Limited consists of a professional team with an average of over 10 year of expertise in the distribution of electronic components. Based in Hongkong, we have already established firm and mutual-benefit business relationships with customers from,Europe,America and south Asia,supplying obsolete and hard-to-find components to meet their specific needs.

With the principle of "Quality Parts,Customers Priority,Honest Operation,and Considerate Service",our business mainly focus on the distribution of electronic components. Line cards we deal with include Microchip,ALPS,ROHM,Xilinx,Pulse,ON,Everlight and Freescale. Main products comprise IC,Modules,Potentiometer,IC Socket,Relay,Connector.Our parts cover such applications as commercial,industrial, and automotives areas.

We are looking forward to setting up business relationship with you and hope to provide you with the best service and solution. Let us make a better world for our industry!



Contact us

Tel: +86-755-8981 8866 Fax: +86-755-8427 6832

Email & Skype: info@chipsmall.com Web: www.chipsmall.com

Address: A1208, Overseas Decoration Building, #122 Zhenhua RD., Futian, Shenzhen, China



FEATURES

- Easy access to the AD7147
- Connects to the USB port of any PC
- Self-contained evaluation system
- ADuC841 host microcontroller
- Range of sensors
 - 128-position slider
 - 5-button cross shape sensor
- Connection for prototype sensor PCBs
- Test points for easy access to signals

APPLICATIONS

- Evaluation of the AD7147
- Evaluation of capacitance sensors

PRODUCT DESCRIPTION

The AD7147 CapTouch™ evaluation board allows the user to evaluate all features of the AD7147 or the AD7147-1. The evaluation software allows the user to test the capacitance sensors, and allows data to be read from and written to the AD7147 or the AD7147-1.

PACKAGE CONTENTS

The AD7147 CapTouch evaluation board kit contains the following items:

- AD7147 CapTouch evaluation board
- USB cable

The following are available online at www.analog.com/AD7147:

- Evaluation software
- EVAL-AD7147 data sheet
- Utility program for software serial downloads

EVALUATION BOARD BLOCK DIAGRAM

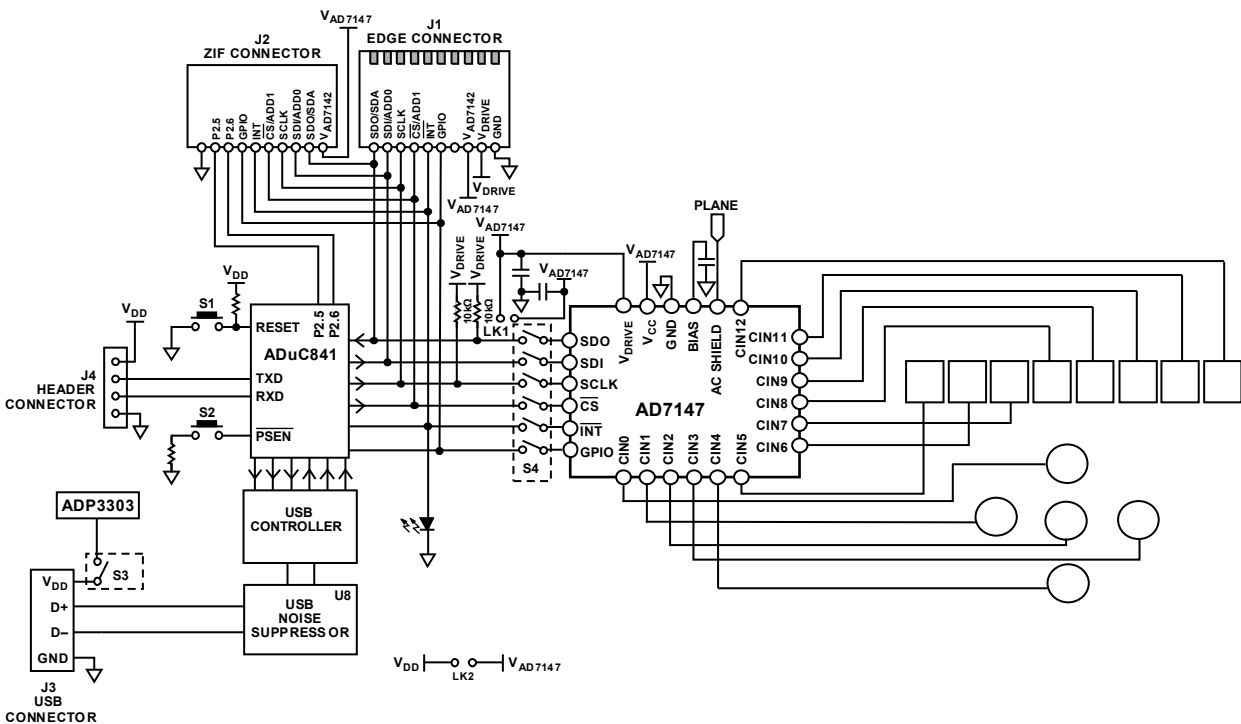

Figure 1.

Rev. 0

Evaluation boards are only intended for device evaluation and not for production purposes. Evaluation boards are supplied "as is" and without warranties of any kind, express, implied, or statutory including, but not limited to, any implied warranty of merchantability or fitness for a particular purpose. No license is granted by implication or otherwise under any patents or other intellectual property by application or use of evaluation boards. Information furnished by Analog Devices is believed to be accurate and reliable. However, no responsibility is assumed by Analog Devices for its use, nor for any infringements of patents or other rights of third parties that may result from its use. Analog Devices reserves the right to change devices or specifications at any time without notice. Trademarks and registered trademarks are the property of their respective owners. Evaluation boards are not authorized to be used in life support devices or systems.

TABLE OF CONTENTS

Features	1	Running the Software	6
Applications.....	1	Evaluation Demo.....	7
Product Description.....	1	Control Tab	8
Package Contents.....	1	Slider Tab.....	9
Evaluation Board Block Diagram.....	1	JoyPad Tab.....	10
Revision History	2	Register Configuration	11
Evaluation Board	3	Input Mux Connection Setup Dialog Box	12
Setting Up the Evaluation Board.....	3	CDC Converter Dialog Box.....	14
Evaluation Board Description	3	Calibration Engine Dialog Box	15
Evaluation Board Hardware.....	4	Excitation Source Dialog Box.....	18
Connectors	4	Ambient Compensation Dialog Box	19
Links.....	4	Interrupt Configuration Registers Dialog Box.....	21
Indicator LED	4	Power Control Dialog Box	22
Switches.....	4	CDC Status Register.....	23
Using an External Host to Communicate with the AD7147 via the Evaluation Board	5	Setup Registers.....	24
Connecting External Sensors to the Evaluation Board.....	5	Schematics and Artwork	25
Upgrading the ADuC841 Firmware	5	Ordering Information.....	28
Evaluation Board Software.....	6	Ordering Guide	28
Installing the Software	6	ESD Caution.....	28

REVISION HISTORY

10/07—Revision 0: Initial Version

EVALUATION BOARD

SETTING UP THE EVALUATION BOARD

Use the following steps to set up the AD7147 evaluation board:

1. Install the evaluation software from the Analog Devices, Inc. website (www.analog.com/AD7147) and click **Evaluation Boards**. Follow the on-screen installation instructions. To complete the installation, accept the licensing agreement.
Note that the software must be installed before the board is plugged in.
2. Ensure that the evaluation board is on a flat, nonconductive surface. Plug the USB connector from the USB port of the PC into the mini-USB socket (J3) on the evaluation board. The power indicator LED on the board should turn on.
3. Ensure that all switches and links are in their default positions; Switch 3 and Switch 4 should be set to the on position.
4. Start the [AD7147](#) evaluation software.

When the evaluation software loads, click **Register Configuration, Evaluation Demo**, or **Exit**. To examine the register setup and compensation algorithm, click **Register Configuration**. To investigate how the on-board sensors work, click **Evaluation Demo**. To exit the software, click **Exit**.

EVALUATION BOARD DESCRIPTION

The AD7147 evaluation board allows the user to evaluate all features of the AD7147. The board is powered via the USB connection to the host PC. The evaluation software allows data to be read from and written to the AD7147. The evaluation software should be installed on the PC before the board is plugged in.

Figure 1 is a block diagram of the AD7147 evaluation board, showing all the main components and how they are connected. Figure 23 shows the silkscreen for the evaluation board to aid in locating components on the board.

The main component on the board is the AD7147 capacitive-to-digital converter. It is connected to six capacitance sensors (one slider and five buttons) and allows the user to evaluate a variety of sensors that may be suitable for a particular application.

An [ADuC841](#) microcontroller is also on the evaluation board. This microcontroller sets up and controls the AD7147 over an SPI or I²C interface. The software processing required for the slider sensor runs on the ADuC841.

The ADuC841 can be disconnected from the on-board sensors and the AD7147 via Switch S4. This allows the user to plug an external sensor PCB into the evaluation board via the ZIF connector, J2, or edge connector, J1. The external sensor board must have an AD7147 mounted on it. It is not possible to use the AD7147 that is located on the evaluation board with external sensors. The ADuC841 on the evaluation board can be used for host communication to an AD7147 on an external sensor board.

The AD7147 evaluation board is powered via the USB connection. The V_{DD} signal goes through an [ADP3303](#) voltage regulator (3.3 V output) before being distributed around the board. There is a USB noise suppression chip to help reduce noise on the D+ and D- USB signals (U8, may not be populated). These signals are routed to a Cypress USB controller IC, which controls the USB interface and connects to the ADuC841.

There are connectors and test points available on all signals of interest to ensure easy access. The LED indicates whether or not the power is active.

EVALUATION BOARD HARDWARE

CONNECTORS

J1

J1 is a 10-way, 0.1 inch edge connector. It provides access to the AD7147 interrupt, GPIO signals, power and ground signals, and its serial interface, or to the ADuC841's interface signals if Switch SW4 is in the off position. J1 allows the user to connect the evaluation board to external sensor boards when SW4 is off.

Table 1. J1 Connector Signals

J1 Pin	Signal
1	SDO/SDA
2	SDI/ADD0
3	SCLK
4	$\overline{\text{CS}}/\text{ADD1}$
5	$\overline{\text{INT}}$
6	GPIO
7	Unconnected
8	V _{AD7147}
9	V _{DRIVE}
10	GND

J2

J2 is a 10-way ZIF connector, which provides access to the AD7147 power and ground signals, as well as to its interface signals, or to the ADuC841's interface signals. If Switch SW4 is in the off position, J2 allows the user to connect the evaluation board to external sensor boards. There are also two ADuC841 GPIOs, P2.5 and P2.6, available on J2.

Table 2. J2 Connector Signals

J2 pin	Signal
1	GND
2	ADuC841 P2.5
3	ADuC841 P2.6
4	GPIO
5	$\overline{\text{INT}}$
6	$\overline{\text{CS}}/\text{ADD1}$
7	SCLK
8	SDI/ADD0
9	SDO/SDA
10	V _{AD7147}

J3

J3 is a mini-USB socket. The USB cable should be connected to this socket. The USB signals (D+ and D-) along with power and ground for the evaluation board, are connected to this socket.

J4

J4 is a 4-way header connector. Power and ground signals, along with RxD and TxD signals from the ADuC841, are available on this connector. This connector can be used for upgrading the firmware on the ADuC841 by connecting a serial download cable to this connector (see the Upgrading the ADUC841 Firmware section).

LINKS

LK1

LK1 connects the V_{DRIVE} input pin on the AD7147 to the power supply of the AD7147.

LK2

LK2 connects the evaluation board's power supply to the power supply of the AD7147.

INDICATOR LED

There is one indicator LED on the AD7147 evaluation board. If the LED is on, the board is powered.

Table 3. Indicator LED

LED	Signal	Color
D1	Power	Green

SWITCHES

The AD7147 evaluation board contains four switches: S1, S2, S3, and S4.

Table 4. Switches

Switch	Type	Description
S1	Push button	ADuC841 reset signal
S2	Push button	ADuC841 PSEN signal, used for downloading code to the ADuC841
S3	Flick switch	Power from USB connector on/off switch
S4	6-input	Connects (on position) or disconnects AD7147 serial interface, $\overline{\text{INT}}$ and GPIO from the ADuC841

USING AN EXTERNAL HOST TO COMMUNICATE WITH THE AD7147 VIA THE EVALUATION BOARD

It is possible for an external host to communicate with the AD7147 via the evaluation board. The AD7147 can be evaluated using the host system's serial interfaces.

An external host can be connected to the AD7147 evaluation board by using Edge Connector J1 or ZIF Connector J2. There are also test points available for connecting to the serial interface (see the Schematics and Artwork section for the location of the serial interface test points).

When the evaluation board is powered up, the on-board ADuC841 microcontroller continuously communicates with the AD7147. When using an external host to communicate with the AD7147, stop the on-board microcontroller from using the serial bus with the following steps:

1. Press the **PROG** button, **S2**.
2. Hold **S2** and press the **RESET** button, **S1**.
3. Release **S1**, keeping **S2** pressed.
4. Release **S2**.

The external host should now be able to use the serial bus to communicate with the AD7147.

CONNECTING EXTERNAL SENSORS TO THE EVALUATION BOARD

It is possible to use the evaluation board software and host microcontroller to evaluate sensors that are connected to the evaluation board. Note that the external sensor PCB must have an AD7147 on board. It is not possible to use the AD7147 hat is on the evaluation board to control external sensors.

1. Power up the evaluation board.
2. Switch S4 to the off position.
3. Connect external sensor PCB to either J1 or J2. The serial interface of the AD7147 on the external sensor PCB is now connected to the serial interface of the ADuC841.

UPGRADING THE ADuC841 FIRMWARE

Occasionally, it may be necessary to upgrade the firmware contained on the ADuC841 microcontroller. In this situation, a software upgrade, in the form of a hexadecimal file, is available from Analog Devices. To download the firmware to the ADuC841, use the software serial download utility program, called WSD, which installs as part of the evaluation software. A cable is required to connect the PC serial port to the evaluation board. This cable, EVAL-ADUC-CABLE1, is also available from Analog Devices. It also comes as part of the evaluation kit for any Analog Devices microcontroller. The firmware can be upgraded by using the following steps:

1. Power up the evaluation board by putting Switch S3 in the on position. LED D1 should turn on.
2. Insert the download cable on the dedicated connector, J4, respecting the polarity. If the LED turns off, the cable is connected incorrectly. Switch the cable's connectors to avoid short circuits on the board.
3. Press the **PROG** button, **S2**.
4. Hold **S2** and press the **RESET** button, **S1**.
5. Release **S1**, keeping **S2** pressed.
6. Release **S2**.
7. Launch the WSD application and click **Configuration**. Under **Crystal Frequency**, select the **Other crystal** option and enter 16. In the **Run** section, click **Run Automatically after download**.
8. Close the **Configuration** dialog box.
9. Click **Download**. A dialog box should open, prompting for the path to the file **.hex**.

Select the path where the firmware upgrade hexadecimal file is stored on your system and click **Open**. The firmware upgrade begins to download, and a progress bar is displayed while the upgrade runs.

EVALUATION BOARD SOFTWARE

The evaluation software is operated in conjunction with the evaluation hardware, and allows you to investigate the properties of the AD7147. The contents of the AD7147 registers can be read or modified, the CDC results can be recorded, and the ambient compensation algorithms can be displayed graphically on-screen.

INSTALLING THE SOFTWARE

The software should be installed before the evaluation board is plugged into the host computer. The evaluation software is installed by running the `AD7147EvaluationSoftwareInstall.exe` program, found at www.analog.com/AD7147 under the **Evaluation Boards** heading. You must agree to the licensing agreement from Analog Devices before installing the software. The software is saved into a **AD7147 Evaluation Software** directory.

RUNNING THE SOFTWARE

Before running the software, ensure that the evaluation board is plugged into the USB port of the host computer. Run the software from the **AD7147 Evaluation Software** directory. Once the software starts running, the **AD7147 Evaluation Software** dialog box appears (see Figure 2). You have three options: **Register Configuration**, **Evaluation Demo**, or **Exit**. **Exit** shuts down the evaluation software, **Evaluation Demo** allows you to investigate the on-board sensors, and **Register Configuration** allows you to investigate the settings of the internal registers on the AD7147.

At the lower left of this dialog box are the software and firmware revision numbers. On the lower right of the dialog box, the AD7147 device ID and silicon revision are displayed. If the device ID is not 147, the software has not initialized properly. In this situation, exit the software and restart it. If an error persists, exit the software, disconnect the USB connector from the board, and reinstall the evaluation software.



Figure 2. AD7147 Evaluation Software Start-Up Dialog Box

EVALUATION DEMO

The evaluation demo software allows you to investigate how the sensors on the AD7147 evaluation board work. Clicking **Evaluation Demo** in the **Evaluation Software Start-Up** dialog box opens the **Evaluation Demo** dialog box shown in Figure 3. This box displays a graphical representation of the on-board sensors. You can operate the buttons, and the slider on the board. The movement or sensor activation is also displayed on-screen. Note that in the **Evaluation Demo** dialog box, the buttons can only be activated individually.

There is a sample application shown in the **Demo** tab. The slider or buttons allow you to choose a country from the list.

There is a separate tab for each of the sensors on the evaluation board, as well as a **Control** tab, which provides access to the conversion and control registers on the [AD7147](#). The individual sensor dialog boxes show the sensors, along with the registers associated with each sensor.

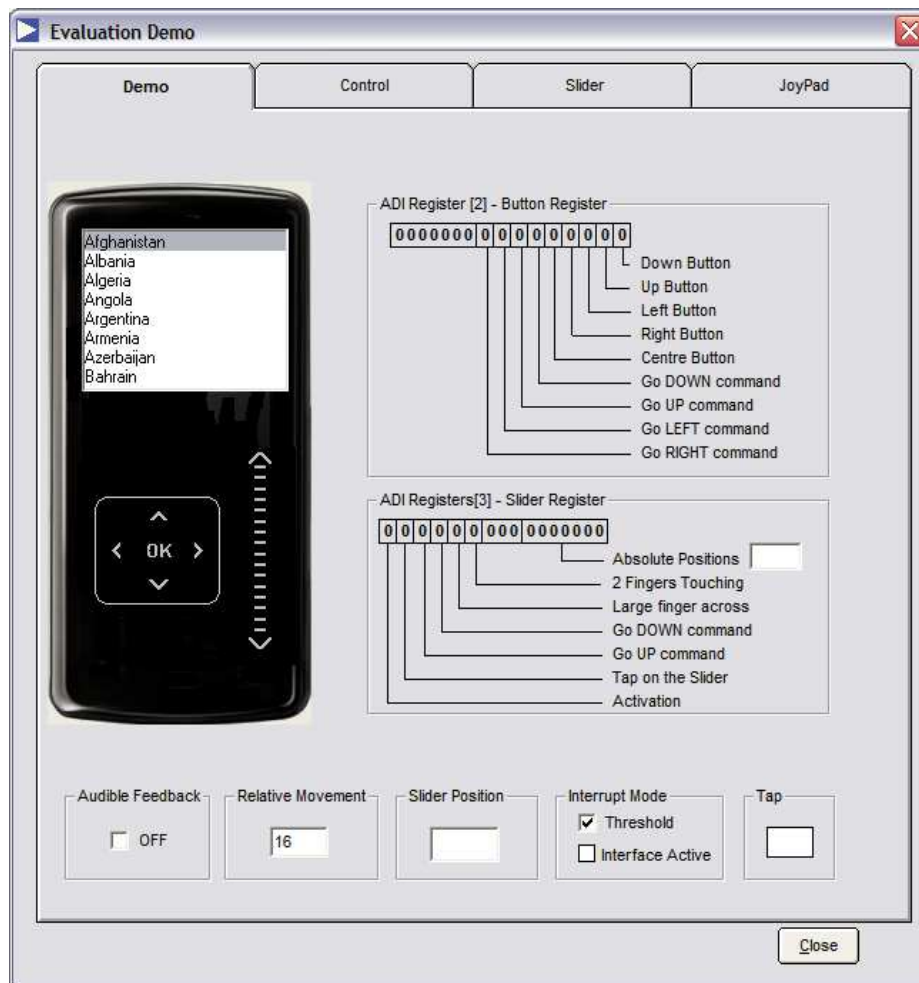

Figure 3. Demo Dialog Box

CONTROL TAB

The **Control** tab allows you change some of the sensor configuration options. For example, you can change the contents of the CDC conversion control registers and the main **AD7147** control register (0x00) to influence the behavior of the sensors. Any changes in the register settings are reflected in the calculated update and timeout variables for **Full Power Mode** (shown as Area 1 in Figure 4) and **Low Power Mode** (shown as Area 2 in Figure 4).

In the **Control Register** (shown as Area 3 in Figure 4), you can change the power mode of the AD7147 to full power, low power, or shutdown mode. You can also alter the low power mode conversion delay, which is the time between conversions in low power mode. The **CDC Conversion Control 0** register (shown as Area 4 in Figure 4) allows you to alter the full power and low power mode skip controls. These settings control how many samples from the CDC are skipped, or not used, in each of the power modes.

The **CDC Conversion Control 1** register (shown as Area 5 in Figure 4) contains the conversion sequencer reset and force calibration buttons, the power down timeout, and the proximity and skip counters. To force the AD7147 to recalibrate the conversion algorithm for all sequencer stages, click **FORCE_CAL**. To reset the sequencer, click **CONV_RESET**. When you come close to a sensor, the proximity status is set. The **Full Power Proximity Time** and **Low Power Proximity Time** variables set the timeout period for the proximity status

in full and low power modes, respectively. These values can be altered using the pull-down menus. The power-down timeout is a multiple of **Low Power Proximity Time**. The drop-down menu allows you to choose this multiple, and hence to set the timeout period, which is the time taken for the AD7147 to go into a low power state when no sensor is touched. The **Fast Filter Skip Control** influences the time required for a conversion sequence on the AD7147. See the AD7147 data sheet for more details on how to use the CDC conversion time value.

The **CDC Conversion Control 2** register (shown as Area 6 in Figure 4) contains the proximity recalibration level, the proximity detection rate, and the slow FIFO update level. The proximity recalibration level and the proximity detection rate control the sensitivity of the proximity detector on the AD7147. The **Slow FIFO Update Level** determines how often the current CDC value is stored in an on-chip FIFO. This FIFO tracks the ambient capacitance value. The settings can be changed by writing a value into the text boxes.

The **CDC Conversion Control 3** register (shown as Area 7 in Figure 4) contains the recalibration timeout values for both full and low power modes. If proximity is set for a period longer than the **Low Power Mode Timer Control** value in low power mode, or longer than the **Full Power Mode Timer Control** value in full power mode, the AD7147 automatically recalibrates the on-chip algorithm.

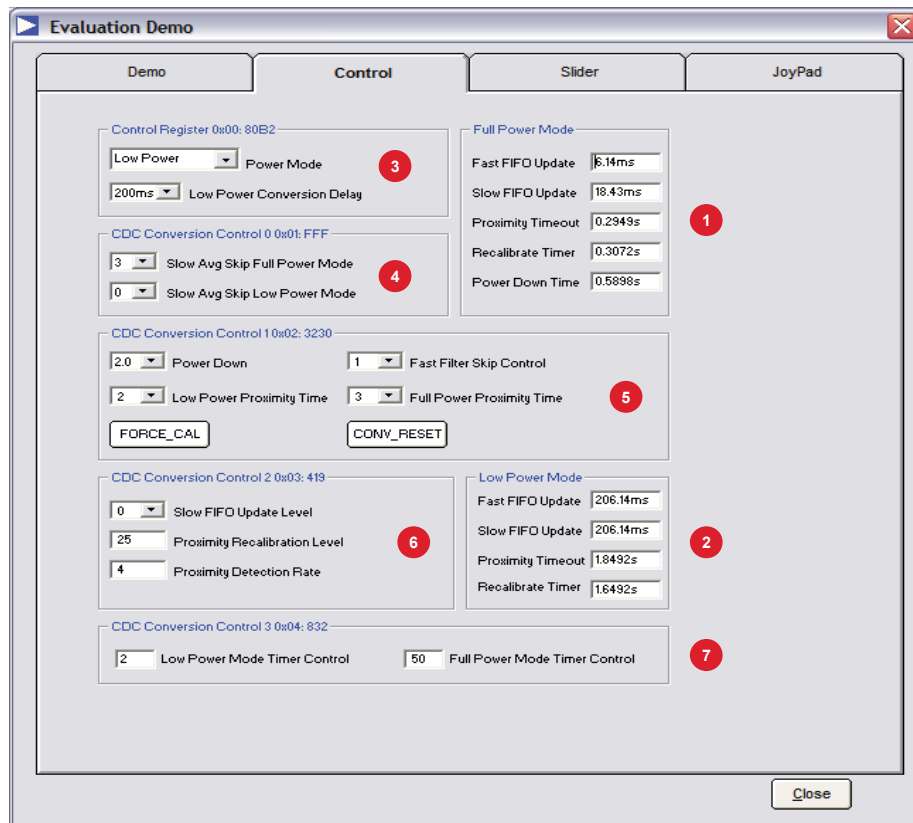

Figure 4. Control Dialog Box
Rev. 0 | Page 8 of 28

SLIDER TAB

Clicking the **Slider** tab opens the dialog box shown in Figure 5. The graphic on the right of the screen represents the slider. The blue bar moves up and down when your finger is moved along the slider. The absolute slider position value is also shown as a number between 0 and 127.

The slider requires 8 sequencer stages on the [AD7147](#): one for each segment of the slider. The segments are measured using Sequencer Stage 0 to Sequencer Stage 7.

The normalized response from each of the sensor segments is shown in Figure 5. As you move your finger along the slider, the response from each segment changes. The response from each segment is used by the microcontroller to calculate the position of the finger on the slider.

The values in the **Upper Threshold Status Register**, **Lower Threshold Status Register** (0x008 and 0x009), and **Proximity Status Register** (0x042) are shown under **Status Registers**.

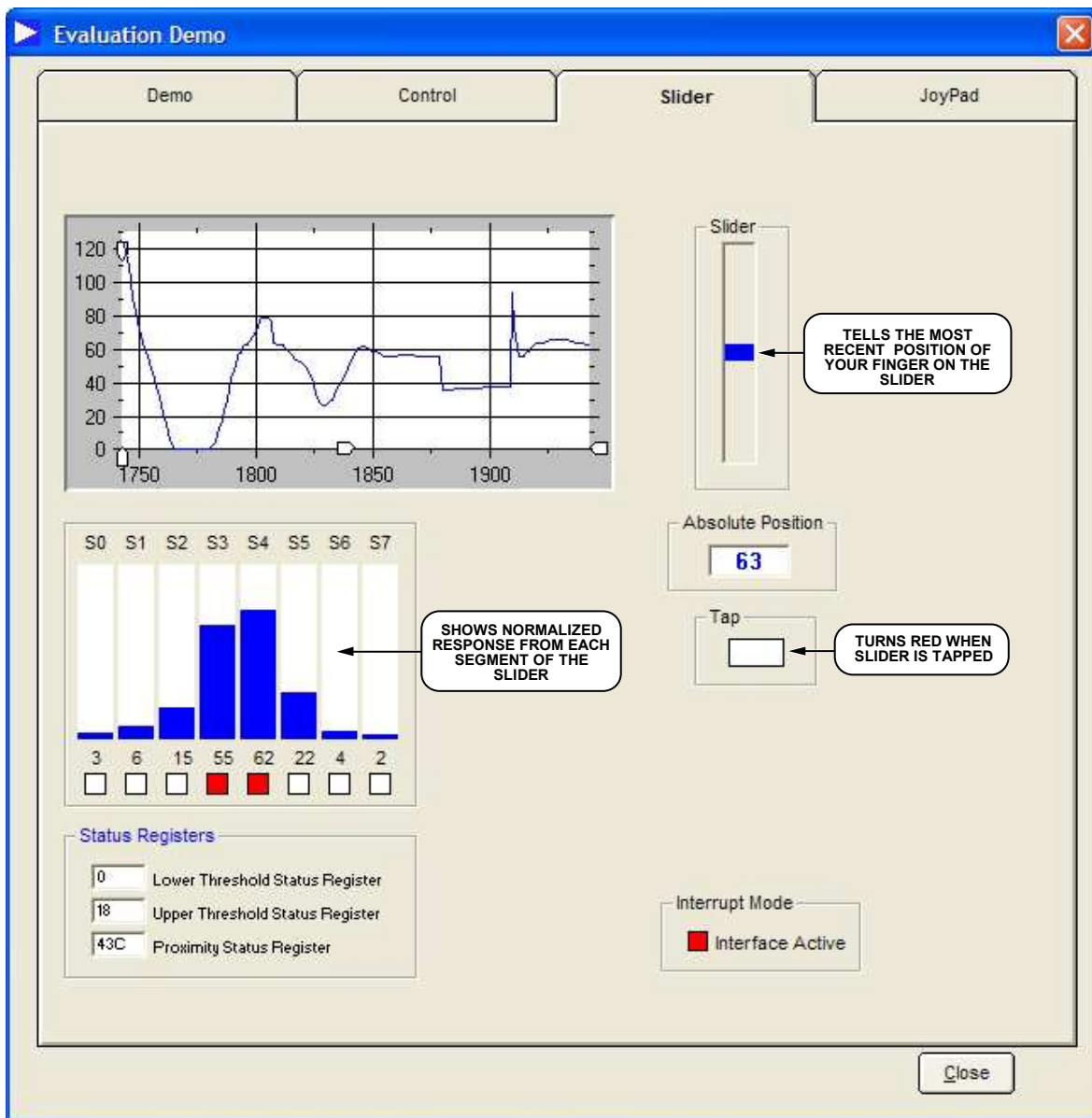

Figure 5. Slider Dialog Box

06924-006

JOYPAD TAB

The **JoyPad** tab opens the dialog box shown in Figure 6. When you activate the joypad, the directional arrows on the graphic turn blue to show the direction of movement. Movement of the blue box is controlled by the joypad; you can move the blue box to different icons around the screen using the joypad or select the center **OK** button.

You can scroll up or down using the joypad. If you move over the center **OK** button while scrolling, it does not activate the button. Only a separate touch on the **OK** button activates it.

ADI Register [2] is shown in the lower right of Figure 6. This register shows the results of the software decoding on the buttons sensor outputs.

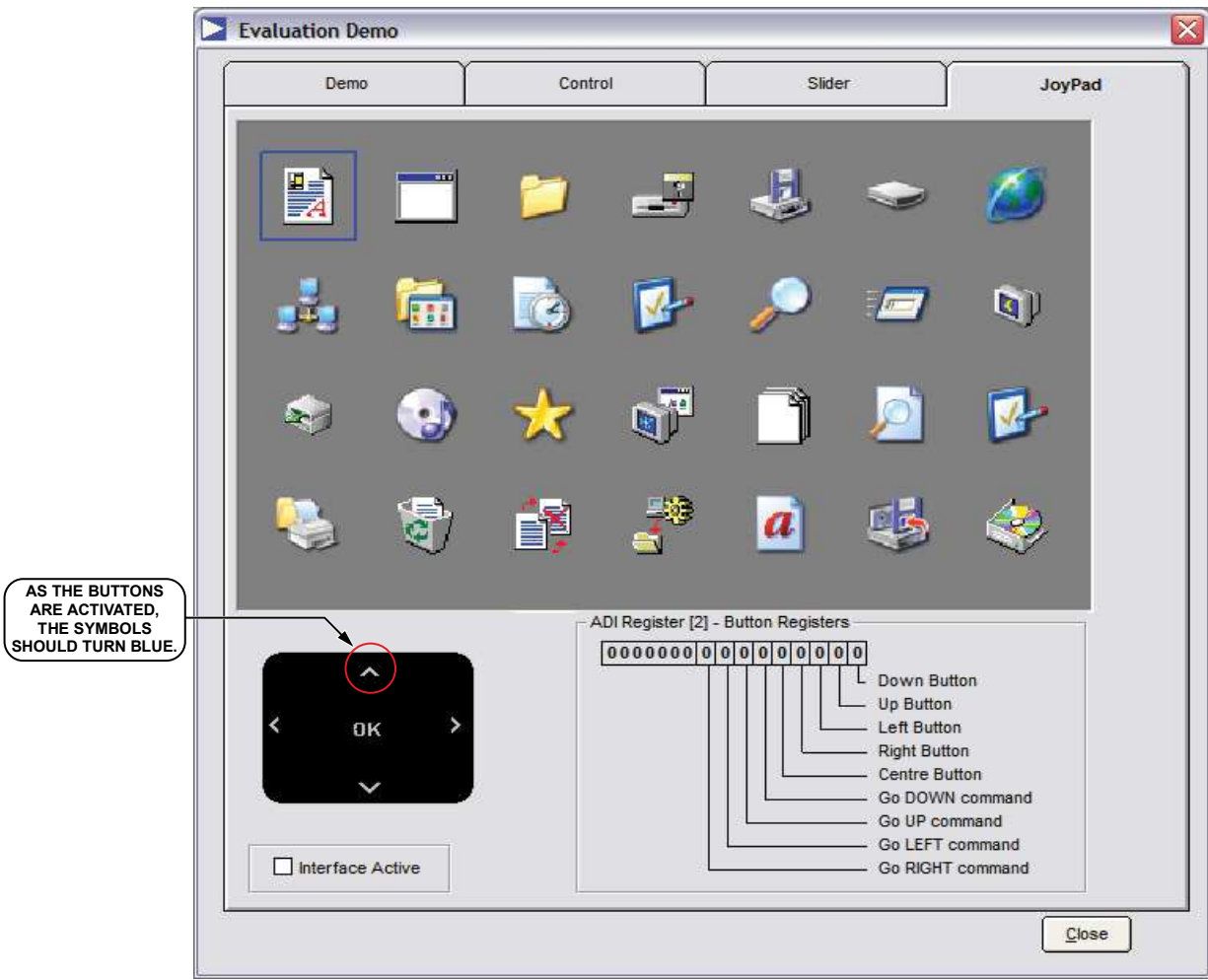

Figure 6. JoyPad Dialog Box

06924-005

REGISTER CONFIGURATION

Click **Register Configuration** in the evaluation start-up dialog box to open the **Register Configuration** dialog box (see Figure 7). The **Register Configuration** dialog box shows a block diagram of the **AD7147**, including blocks that represent the inputs from the sensors, the input multiplexer, the sequencer stage setup registers, the CDC, the calibration engine, and the other setup registers. By clicking a block, you can access the registers associated with that block. The evaluation board has either an AD7147 with SPI interface or an AD7147-1 with I²C interface. The evaluation software shows which interface the device is configured for in the lower left corner of the **Register Configuration** dialog box. Click **Close** at the lower right of the screen to close the **Register Configuration** dialog box.

The AD7147 block diagram is a representation of the internal structure of the AD7147. The CIN inputs, CIN0 to CIN12, are connected to the input multiplexer, which contains blocks to represent the input connection settings for each sequencer stage. The output of the multiplexer is connected to the CDC converter, which in turn is connected to the calibration engine. The

calibration engine contains blocks that represent the calibration setup for each sequencer stage.

The AD7147 registers must be programmed so the part functions correctly. The AD7147 evaluation software has an easy setup utility that programs the AD7147 registers with appropriate setup values. This utility is run by clicking **Easy SetUp** at the lower left of the **Register Configuration** dialog box. After this button is clicked, all registers on the AD7147 are then set up automatically.

The **Create Config File** button saves your selected register Configuration values to a header file that can be incorporated into your code.

The **Initialise CIN Inputs** button changes all the STAGE_CONNECTION[6:0] register values to 0xFF, and all the STAGE_CONNECTION[12:7] register values to 0x3FFF. Use this when connecting an external sensor and AD7147 to the evaluation board, before debugging.

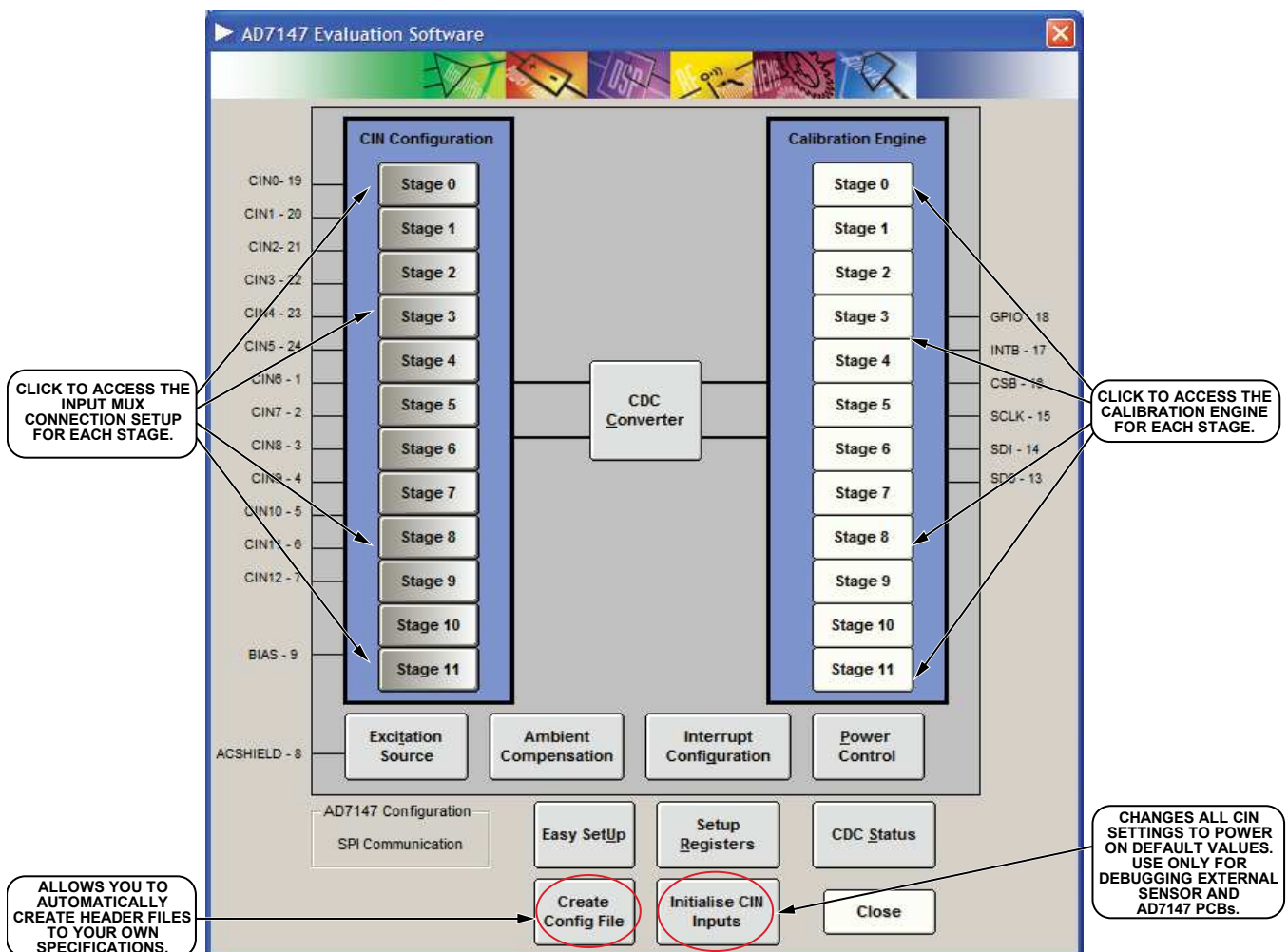

Figure 7. Register Configuration Dialog Box

INPUT MUX CONNECTION SETUP DIALOG BOX

To access the registers that control the input multiplexer connection setups for each sequencer stage, click the block representing that stage in the input mux section of the block diagram. For example, clicking the Sequencer Stage 8 block in the input mux opens the dialog box shown in Figure 8. Similar dialog boxes are opened for each of the other stages.

Input Mux Configuration

For each sequencer stage, each capacitive input, CIN 0 to CIN 12, can be connected to the positive or negative input of the CDC, left floating, or tied to the bias voltage. To connect CIN to the positive CDC input, select the **+ input path** check box. To connect CIN to the negative CDC input, select the **- input path** check box. Selecting both boxes connects the input to bias,

and clearing both boxes leaves the input floating. The dialog box also displays the register locations where the connection settings are stored.

The CIN connection settings for each conversion stage depend on the type of sensors and their connection to the AD7147. For example, the up button on the joypad is connected to the AD7147 through CIN 1 and the down button is connected through CIN 3. To configure these buttons to operate correctly for Sequencer Stage 8, all CIN inputs should be connected to bias for that stage, with the exception of CIN 1, which should be connected to the positive input path to the CDC and CIN 3 which should be connected to the negative. For more information on configuring the sequencer stage connection setups for particular sensors, see the AD7147 data sheet.

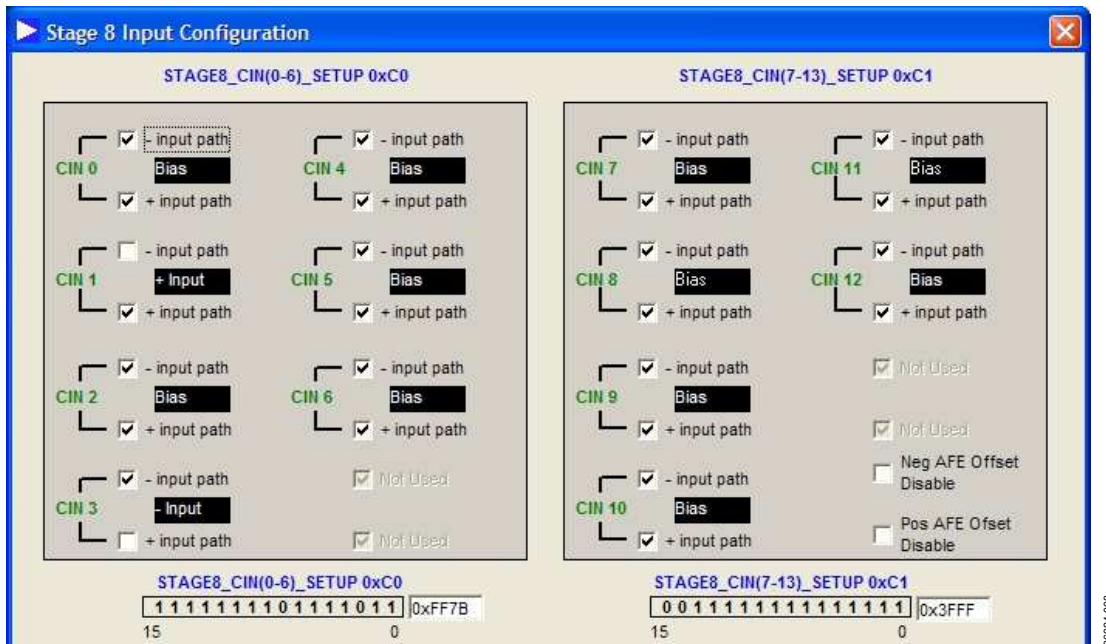

Figure 8. Sequencer Stage 8 Input Configuration Dialog Box, Upper Section

Analog Front-End Offset Control

To ensure that the full range of the AD7147 converter is used for each sensor, an offset can be added to or subtracted from the voltage at the input of the converter. When the sensor is not being touched, the output of the converter should be midscale, output code of around 32,768. Program the offset DACs so that the converter output is as close as possible to midscale.

Figure 9 shows the analog front-end (AFE) offset register contents. You can change the value of the AFE input offset for each stage by changing the output of the offset DAC. Both the

negative and positive offsets can be altered, and the offsets can be swapped by selecting the check boxes provided. You can disable the positive and negative offsets for the sequence stage by selecting the **Neg AFE Offset Disable** and **Pos AFE Offset Disable** check boxes (see Figure 8), located in the upper right-hand section of the **Setup Register** dialog box.

The **Get Offset** button automatically programs the correct values into the **POS_AFE_OFFSET** and **NEG_AFE_OFFSET** registers.

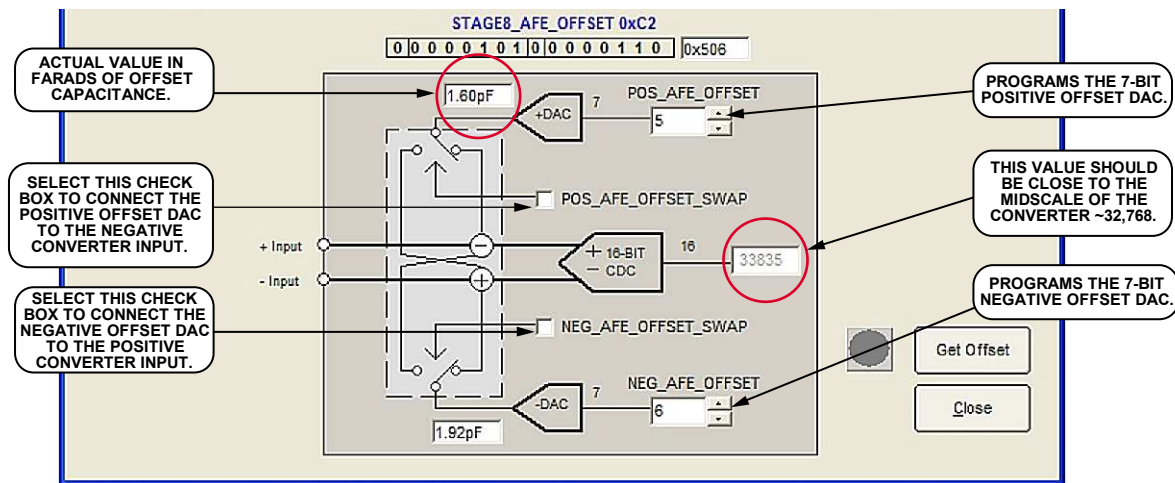

Figure 9. Sequencer Stage 8 Input Configuration Dialog Box, Lower Section

06924-009

EVAL-AD7147

CDC CONVERTER DIALOG BOX

Clicking **CDC Converter** in the **Register Configuration** dialog box opens the box shown in Figure 10. This box shows the contents of the **AD7147** control register. You can change the number of sequencer stages and the decimation factor and increase the CDC modulator bias current by using the drop-down menus provided. The number of required sequencer stages depends on the sensors attached to the AD7147. For

all sensors on the evaluation board to operate correctly, this value should be set to 11. The decimation rate is the factor by which the CDC output is oversampled by the AD7147.

You can plot the values of each of the conversion stages (**CDC_RESULT_SX** registers, from address 0x00B to 0x016) in this window. Ticking the box for a stage displays the CDC result for that stage on the graph.

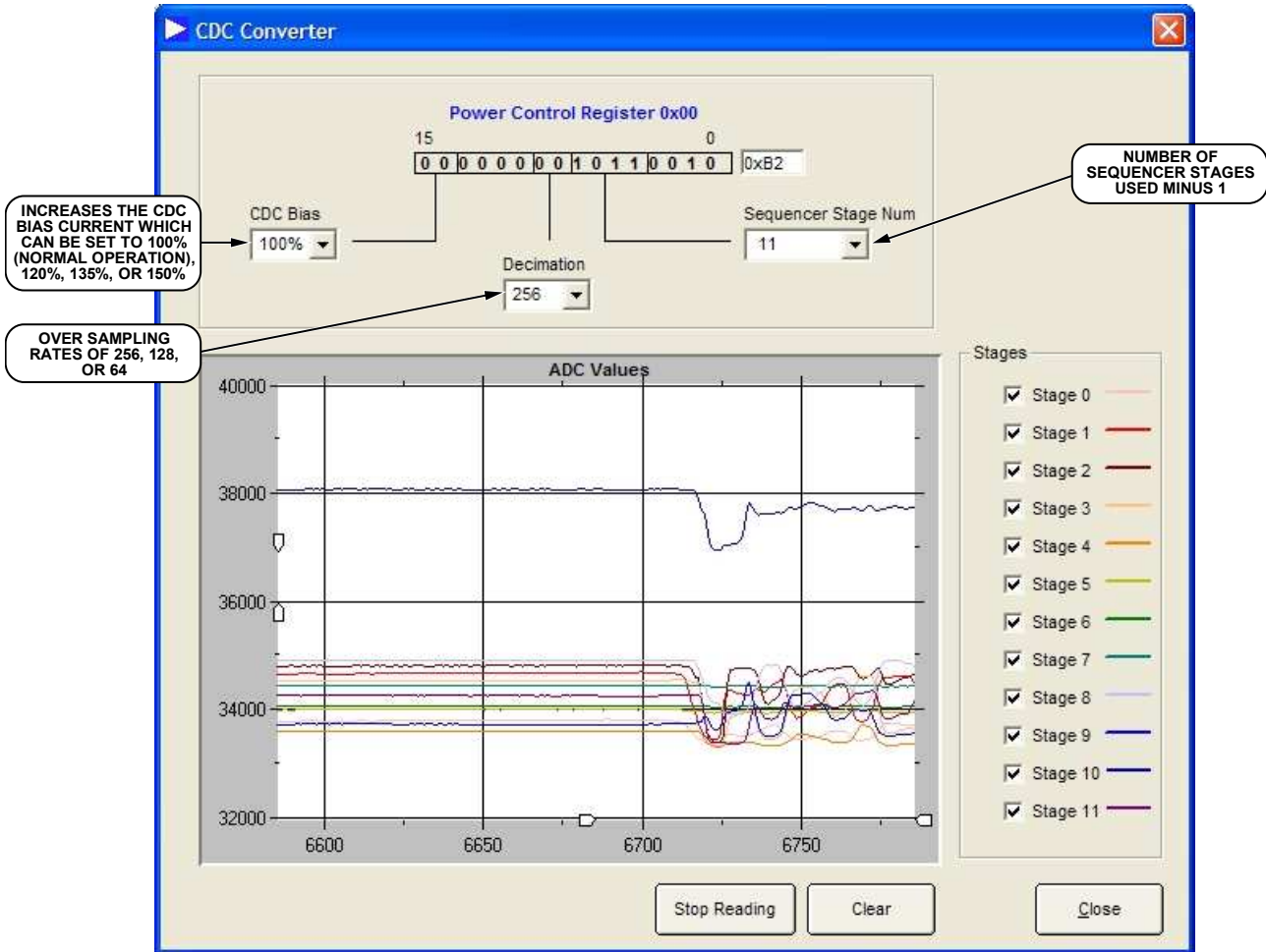

Figure 10. CDC Converter Dialog Box

06924-010

CALIBRATION ENGINE DIALOG BOX

To access the calibration engine settings for each sequencer stage, click the block representing that stage in the **Calibration Engine** area of the block diagram. The dialog boxes shown in this section are opened by clicking the block representing Sequencer Stage 0 in the calibration engine. Similar dialog boxes can be opened for each sequencer stage.

Figure 11 shows the right-hand section of the **Stage 0 Calibration Engine** dialog box. This area of the box shows a graphical representation of the calibration algorithm processing the CDC data for Sequencer Stage 0. The actual CDC value is plotted, along with the maximum and minimum threshold values, the maximum and minimum average CDC values, and the ambient or background capacitance value. The current values and the graph legend are shown directly above the graphing area.

To see the current values used by the **AD7147** to run the calibration algorithm, click **Read Continuously** at the bottom of the screen. The graph is continuously updated with new values from the AD7147. **Force Calibration** forces the AD7147 to recalibrate all the algorithm values, **Clear Graph** clears the graphing window, and **Close** closes the window. To save the values that are shown on the graph, select the **Save Results** check box at the lower left of the dialog box. The values are then exported to a delimited text file.

While the sensor associated with Stage 0 is not touched, the CDC value is equal to the ambient value. The Stage 0 proximity indicator at the top of the dialog box turns red when someone is close to the sensor. When the proximity indicator is red, the ambient value is not updated, but the CDC value is. If the CDC value exceeds either the minimum or maximum threshold, the Stage 0 low or high limit indicator at the top of the screen turns green, indicating that the AD7147 registered a valid touch. The minimum and maximum average values are updated while the algorithm runs (this is also displayed on the graph in Figure 11).

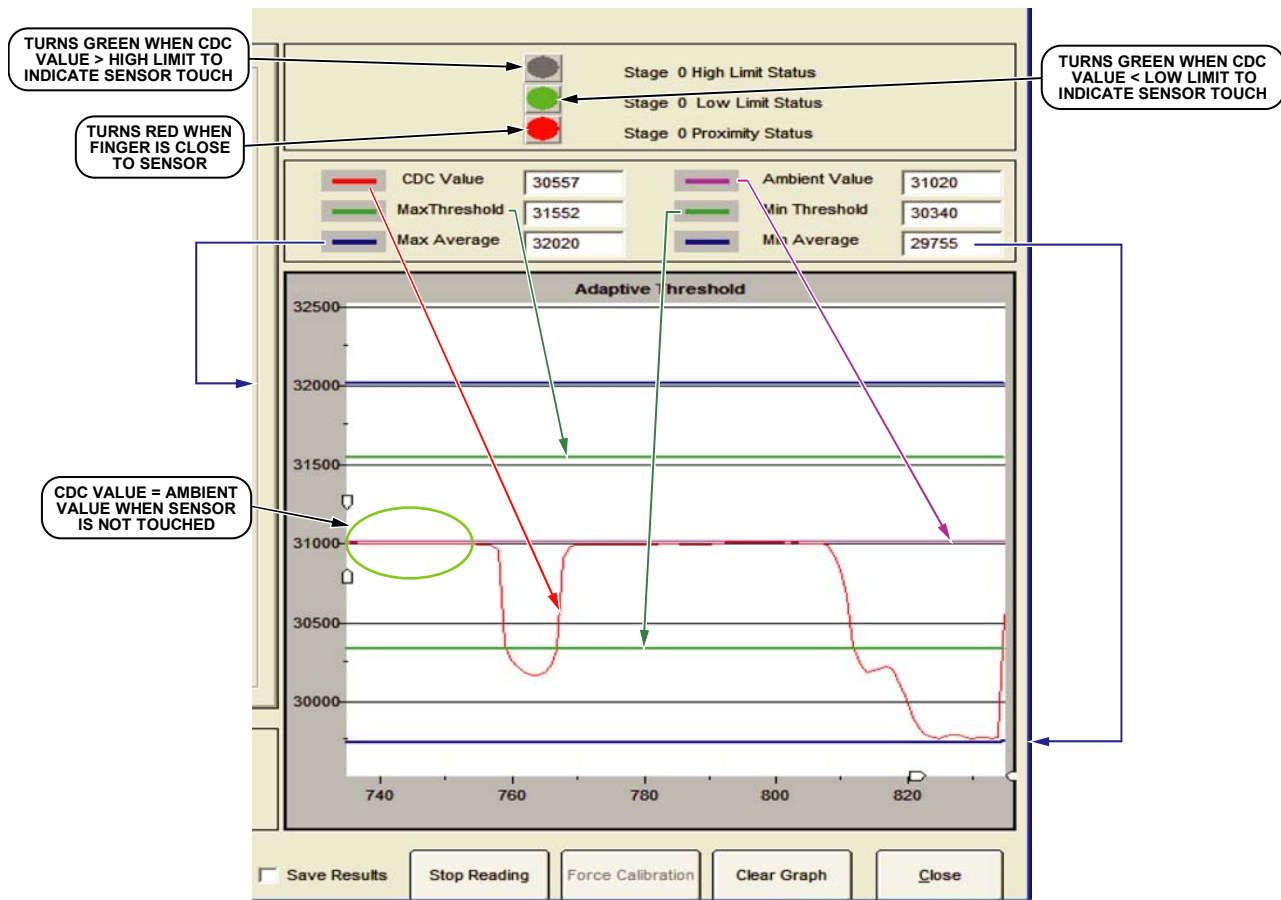

Figure 11. Stage 0 Calibration Engine Dialog Box—Right-Hand Side

06824-011

EVAL-AD7147

The left-hand side of the **Calibration Engine** dialog box (see Figure 12) has two tabs: **Initial Setup** and **RAM Data**. The **Initial Setup** dialog box is shown in Figure 12. This section of the box shows the initial setup values for the clamp, offset, and sensitivity registers for the AD7147 calibration algorithm. It also allows you to alter the sensitivity of each sensor by adjusting the maximum and minimum threshold values. The threshold values are calculated by the AD7147 on-chip, using the formula

shown in Figure 13. To view this formula, click **Calc Threshold** for either the minimum or maximum threshold (see Figure 13).

You can choose the sensitivity level of each sensor by using the drop-down menu. When the upper sensitivity setting is changed, the maximum threshold is recalculated, and the graph is redrawn with the new value. When the lower sensitivity setting is changed, the minimum threshold is recalculated, and the graph is redrawn with the new value.

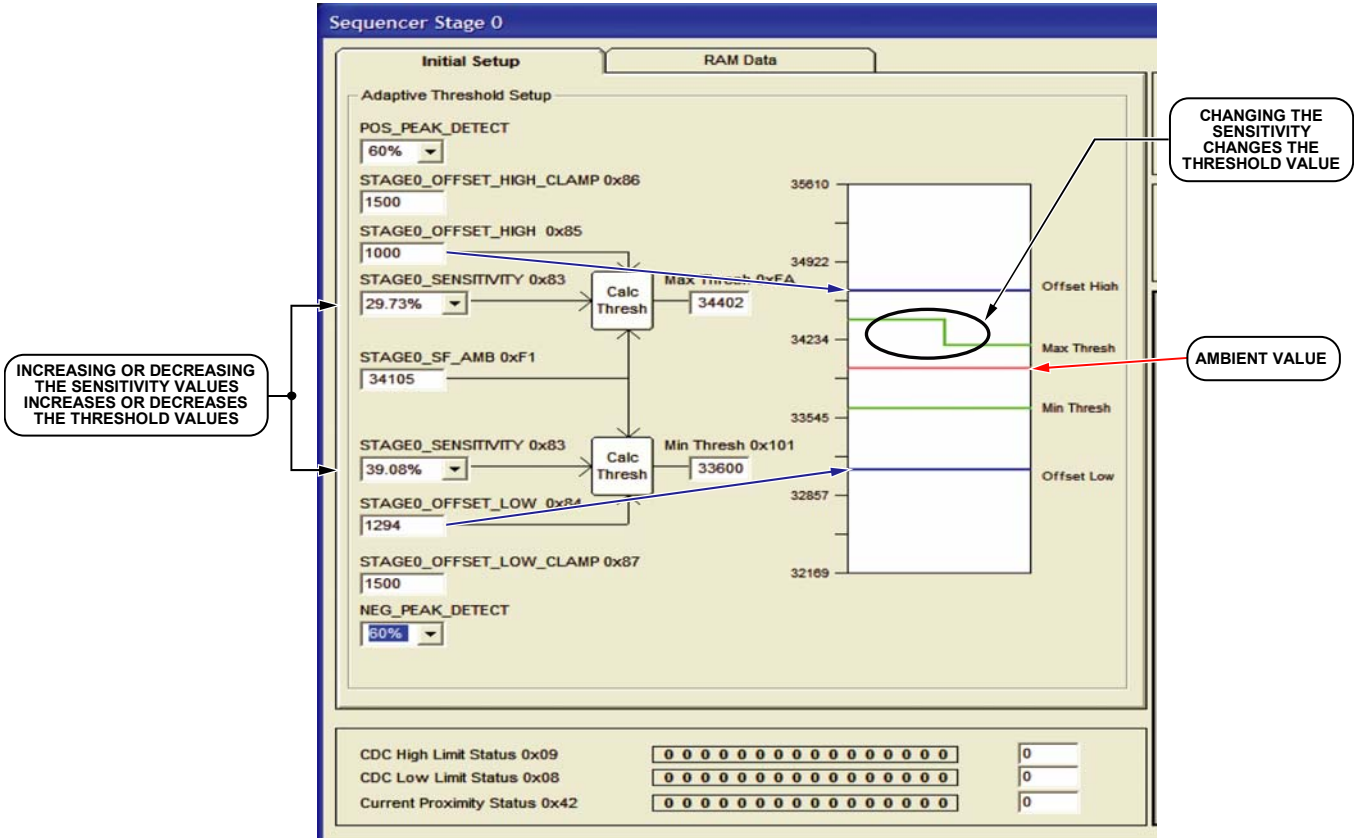

Figure 12. Sequencer Stage 0 Initial Setup Dialog Box

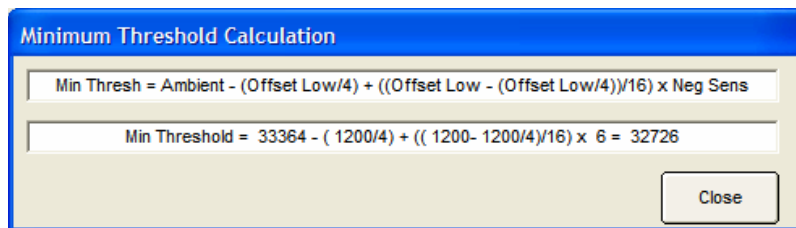

Figure 13. Minimum Threshold Formula

The dialog box for the **RAM Data** tab on the left-hand side of the **Calibration Engine** dialog box is shown in Figure 14. This box shows the contents of the on-chip RAM (Bank 3 registers) used during the calculation of the maximum and minimum thresholds for Sequencer Stage 0. These values reside in

memory on the [AD7147](#) and are constantly updated while the AD7147 is in read continuously mode.

At the lower left-hand side of the dialog box, the contents of the CDC low, CDC high, and current proximity status registers are displayed.

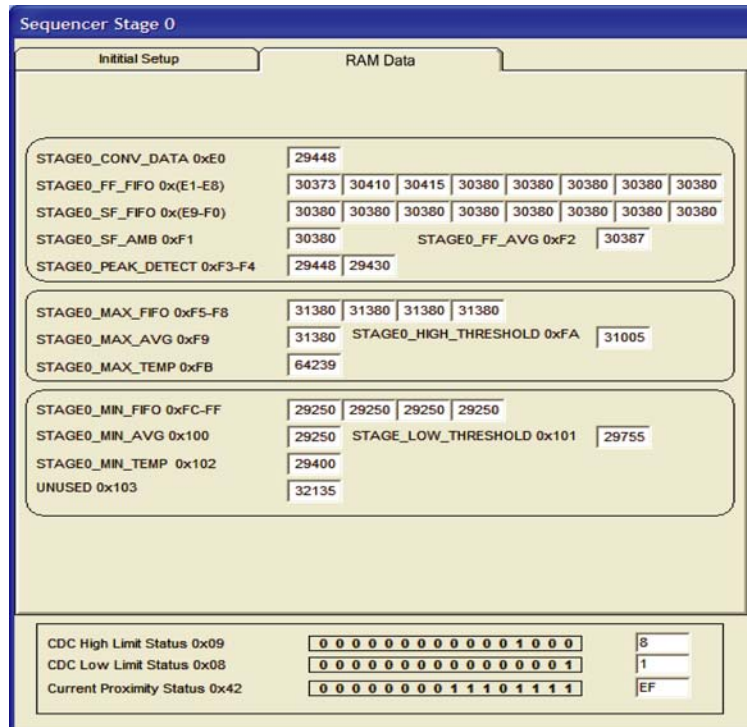

Figure 14. Sequencer Stage 0 RAM Data Dialog Box

EXCITATION SOURCE DIALOG BOX

By clicking **Excitation Source** in the **AD7147** block diagram (see Figure 1), the dialog box shown in Figure 15 opens. This box allows you to disable the on-chip excitation source. The bit that controls this function is located in the Control Register 0x00. Selecting the **Excitation Source Disable** check box

disables the on-chip excitation source. Note that disabling the excitation source stops the sensors from working.

Checking the **Floating Mode Enable** box changes the operation of the AD7147 from a grounded sensor mode to floating sensor mode. Do not use this function with single electrode sensors.

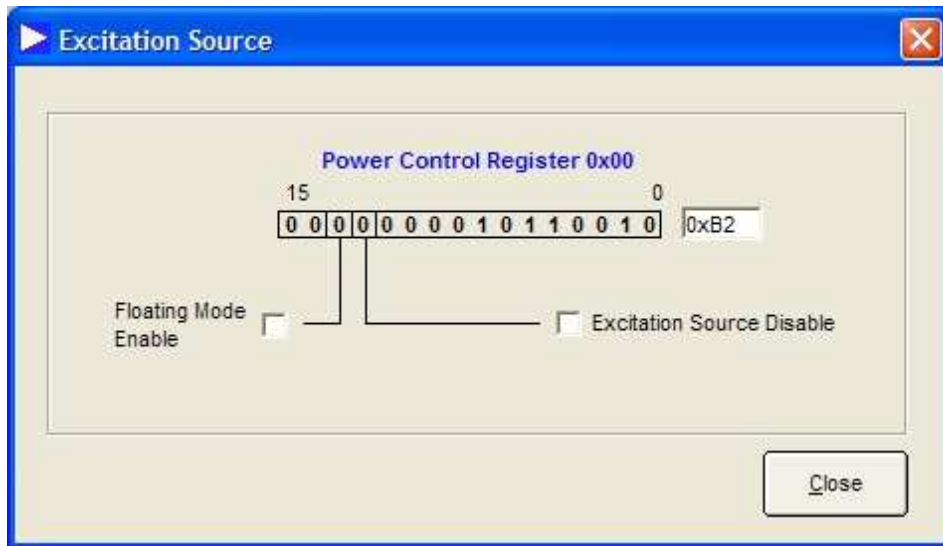

Figure 15. Excitation Source Dialog Box

08924-015

AMBIENT COMPENSATION DIALOG BOX

Clicking **Ambient Compensation** in the [AD7147](#) block diagram (see Figure 1) opens the **Ambient Compensation** dialog box (see Figure 16). This box provides access to all four CDC conversion control registers. These registers contain the global conversion controls for the AD7147.

In the **CDC Conversion Control 0** register, Bit 0 to Bit 11 are calibration enable bits for Sequencer Stage 0 to Sequencer Stage 11. To enable the calibration routine for a sequencer stage, select the check box corresponding to that stage. This register also contains the full power (**AVG_FP_SKIP**) and low power (**AVG_LP_SKIP**) skip controls. These settings control how many samples from the CDC are skipped, or not used, in each power mode. You can choose values from the drop-down menus.

The **CDC Conversion Control 1** register contains the sequencer reset and force calibration bits, the power-down timeout, and the proximity and skip counters. To force the AD7147 to recalibrate the conversion algorithm for all sequencer stages, select **FORCE_CAL**. To reset the sequencer, select **CONV_RESET**. When a user comes close to a sensor, the proximity status is set. **FP_PROXIMITY_CNT** and **LP_PROXIMITY_CNT** set the timeout period for the proximity status in full and low power modes, respectively. These values can be altered using the drop-down menus. The power-down timeout is a multiple of the **LP_PROXIMITY_CNT**. The **PWR_DOWN_TIMEOUT** drop-down menu allows you to choose this multiple, and hence to set the timeout period (which is the time taken for the AD7147 to go into a low power state when no sensor is touched). **FF_SKIP_CNT**

influences the time required for a conversion sequence on the AD7147. See the AD7147 data sheet for more details on how to change the CDC conversion time and other values.

The **CDC Conversion Control 2** register contains the proximity recalibration level, proximity detection rate, and slow filter level. The proximity recalibration level and proximity detection rate control the sensitivity of the proximity detector on the AD7147. These settings can be changed by writing a value into the text boxes. The **SLOW_FIFO_LVL** setting is changed by choosing a value from the drop-down menu. This setting determines if the current CDC value is stored in the slow FIFO.

The **CDC Conversion Control 3** register contains the recalibration timeout values for both full and low power modes. If proximity is set for a period longer than the **LP_PROXIMITY_RECAL** in low power mode or the **FP_PROXIMITY_RECAL** in full power mode, the AD7147 automatically recalibrates the on-chip algorithm.

The **Full Power Mode** area at the right of the dialog box shows the current on-chip settings for full power mode. It contains the fast and slow FIFO update rates, the proximity timeout value, the recalibration value, and the power-down timer value. In addition, changes in the ambient compensation registers are reflected in this section.

The **Low Power Mode** area shows the current on-chip settings for low power mode, including the fast and slow FIFO update rates, the proximity timer, and the recalibration timer values. Changes in the ambient compensation registers cause these values to update.

Ambient Compensation

CDC Conversion Control 0 0x01

15 0
0 0 0 0 1 1 1 1 1 1 1 1 1 1 1 1 0xFFF

AVG_LP_SKIP: 0 | AVG_FP_SKIP: 3

CHOOSE NUMBER OF SAMPLES TO SKIP IN LOW AND FULL POWER MODES

- STAGE0_CAL_EN
- STAGE1_CAL_EN
- STAGE2_CAL_EN
- STAGE3_CAL_EN
- STAGE4_CAL_EN
- STAGE5_CAL_EN
- STAGE6_CAL_EN
- STAGE7_CAL_EN
- STAGE8_CAL_EN
- STAGE9_CAL_EN
- STAGE10_CAL_EN
- STAGE11_CAL_EN

SELECT THESE CHECK BOXES TO ENABLE THE CALIBRATION DATA PATH FOR EACH SEQUENCER STAGE

CDC Conversion Control 1 0x02

15 0
0 0 0 0 0 0 1 1 1 0 0 1 0 0 0 0 0x390

CONV_RESET, FORCE_CAL, PWR_DOWN_TIMEOUT: 1.25

FF_SKIP_CNT: 0 | FP_PROXIMITY_CNT: 9 | LP_PROXIMITY_CNT: 3

Full Power Mode

Fast FIFO Update	36.86ms
Slow FIFO Update	110.59ms
Proximity Timeout	5.3084s
Recalibrate Timer	19.9803s
Power Down Time	6.6355s

CDC Conversion Control 2 0x03

15 0
0 0 0 0 0 0 1 0 0 1 1 0 0 1 0 0 0x264

SLOW_FIFO_LVL: 0 | PROXIMITY_RECAL_LVL: 100 | PROXIMITY DETECTION RATE: 2

Low Power Mode

Fast FIFO Update	436.86ms
Slow FIFO Update	436.86ms
Proximity Timeout	5.6424s
Recalibrate Timer	19.2220s

CDC Conversion Control 3 0x04

15 0
0 0 1 0 1 1 1 0 0 0 0 1 1 1 1 0 0x2E1E

LP_PROXIMITY_RECAL: 11 | FP_PROXIMITY_RECAL: 542

Close

Figure 16. Ambient Compensation Dialog Box

06924-016

INTERRUPT CONFIGURATION REGISTERS DIALOG BOX

Click **Interrupt Configuration** in the main **AD7147** block diagram (see Figure 1) to open the dialog box shown in Figure 17. The dialog box allows you to control the interrupt settings for the AD7147.

The **Stage Low Interrupt Enable** register contains the low interrupt enable bits for Sequencer Stage 0 to Sequencer Stage 11. If the result of a sequencer stage crosses the lower threshold setting for that stage, $\overline{\text{INT}}$ is triggered if the relevant bit is set to 1. The interrupt enable for each stage is set by selecting the relevant check box. This register also contains the GPIO configuration and setup bits. **GPIO_INPUT_CONFIG** can be set by using the drop-down menu, which causes $\overline{\text{INT}}$ to trigger in response to either a negative or positive edge or to level on the GPIO pin when it is configured as an input. **GPIO_SETUP** can disable the GPIO function or configure the GPIO as an

input or as a low or high output. These settings can be altered by using the drop-down menus.

The **Stage High Interrupt Enable** register contains the high interrupt enable bits for Sequencer Stage 0 to Sequencer Stage 11. If the result of a sequencer stage crosses the upper threshold setting for that stage, $\overline{\text{INT}}$ is triggered if the relevant bit is set to 1. The interrupt enable for each stage is set by selecting the relevant check box.

The **Stage Complete Interrupt Enable** register contains the sequencer stage complete interrupt enable bits. To enable the interrupt once a sequencer stage has completed a conversion, select the relevant check box. The GPIO interrupt enable bit (**GPIO_INT_EN**) is also in this register. If this bit is set, the GPIO can trigger the $\overline{\text{INT}}$ output. The interrupt polarity bit (**INT_POL**), which resides in the **Control Register** is also shown in Figure 17. Setting this bit to 1 by selecting the relevant check box sets $\overline{\text{INT}}$ polarity to active high. Setting this bit to 0 sets $\overline{\text{INT}}$ polarity to active low.

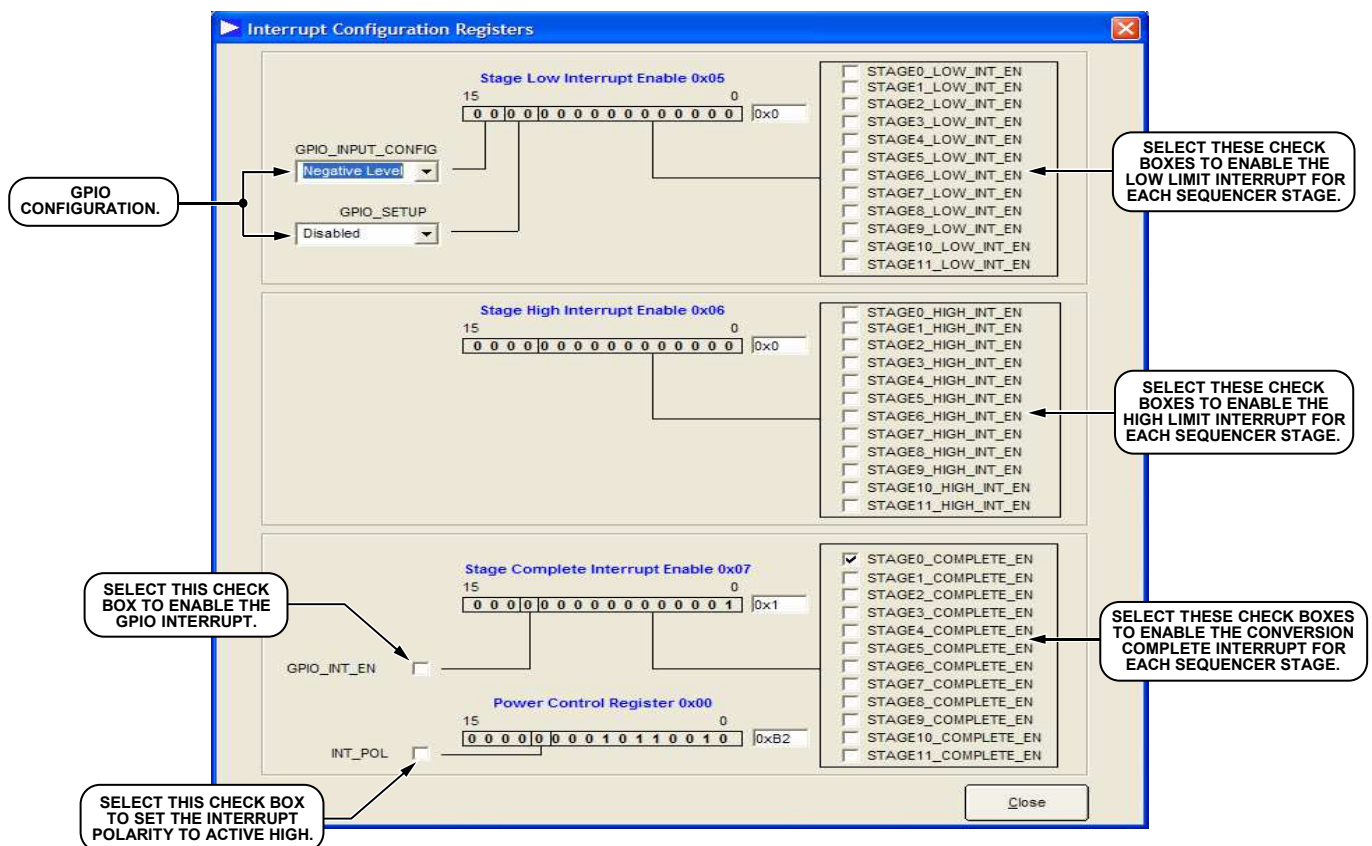

Figure 17. Interrupt Configuration Registers Dialog Box

EVAL-AD7147

POWER CONTROL DIALOG BOX

By clicking **Power Control** in the block diagram (see Figure 1) of the **AD7147**, the dialog box shown in Figure 18 opens. This box shows the contents of the control register that relate to power control for the AD7147.

To perform a software reset, click **SW_RESET**. This bit is self-clearing. You can put the AD7147 into shutdown, low power, or

full power mode by selecting the relevant option in the **POWER_MODE** drop-down menu. You can also alter the low power mode conversion delay by using the **LP_CONV_DELAY** drop-down menu, which allows you to choose a 200 ms, 400 ms, 600 ms, or 800 ms delay. The greater the delay between conversions, the greater the power savings you can achieve in low power mode.

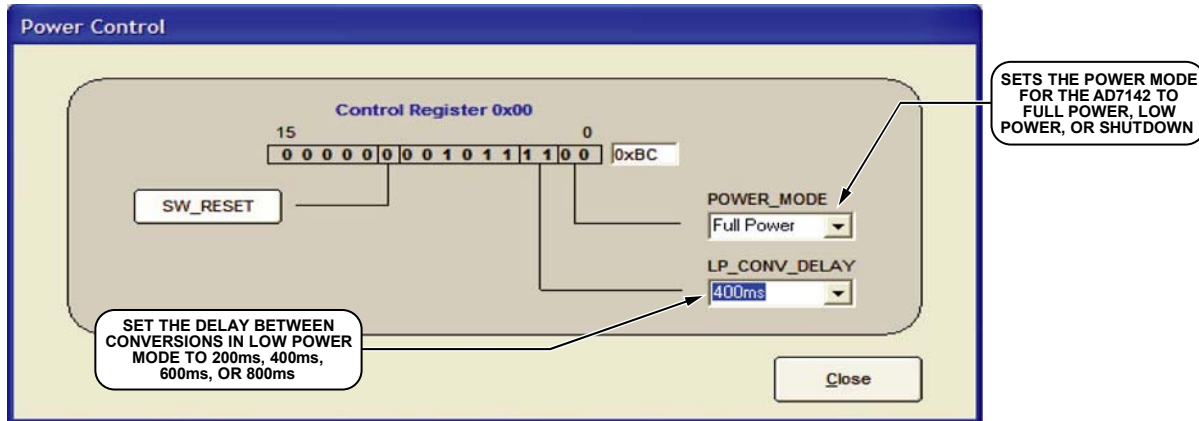

Figure 18. Power Control Dialog Box

06924-018

CDC STATUS REGISTER

By clicking **CDC Status** in the block diagram (see Figure 1) of the [AD7147](#), the **CDC Status** dialog box shown in Figure 19 opens. This box allows you to view the CDC status registers, which are read-only and cannot be modified by the user. When the interrupt is triggered, a 1 in any of the registers indicates the interrupt trigger. The **Stage Low Limit Interrupt** register

indicates which, if any, sequencer stage has exceeded its lower threshold. The **Stage High Limit Interrupt** register indicates which, if any, sequencer stage has exceeded its upper threshold. The **Stage Complete Limit Interrupt** register indicates which, if any, sequencer stage has triggered a conversion complete interrupt.

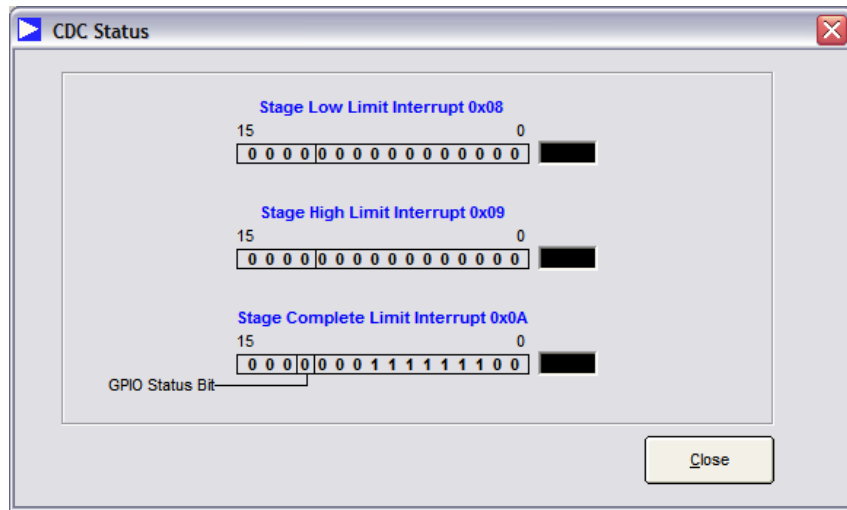

Figure 19. CDC Status Dialog Box

EVAL-AD7147

SETUP REGISTERS

The **Setup Registers** dialog box (see Figure 20) allows you to save and load AD7147 register settings to and from a text file. These setup registers contain values to set up the calibration and proximity detection routines on-chip for each sequencer stage, as well as general-purpose setup values for the AD7147.

The **Main Initial Setup** values are shown on the upper left-hand side of the dialog box. You can also write to or read from a specific register address by typing the register address and the value to be written for a write into the **Write To Register** area.

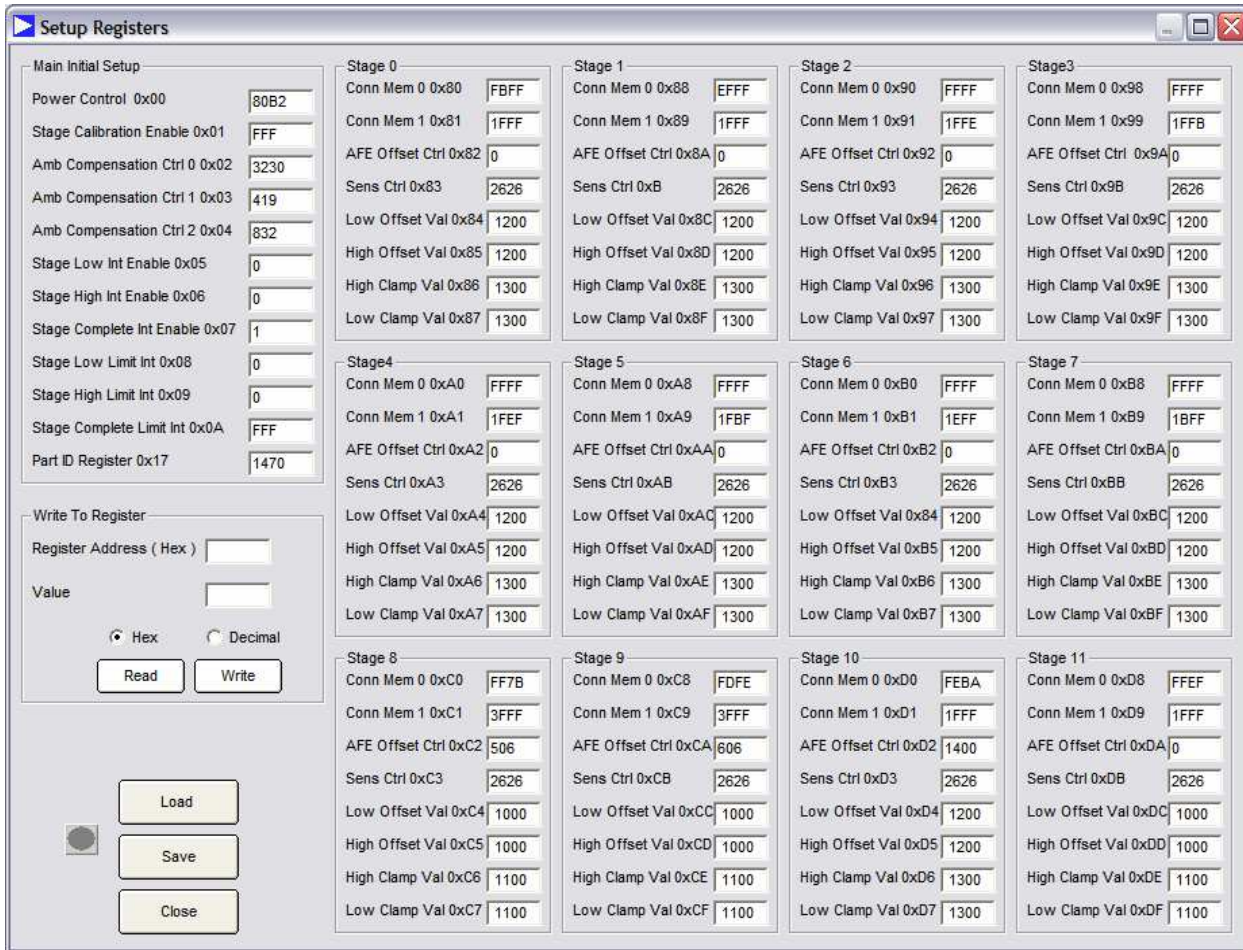

Figure 20. AD7147 Setup Registers

08924-020

SCHEMATICS AND ARTWORK

6924-021

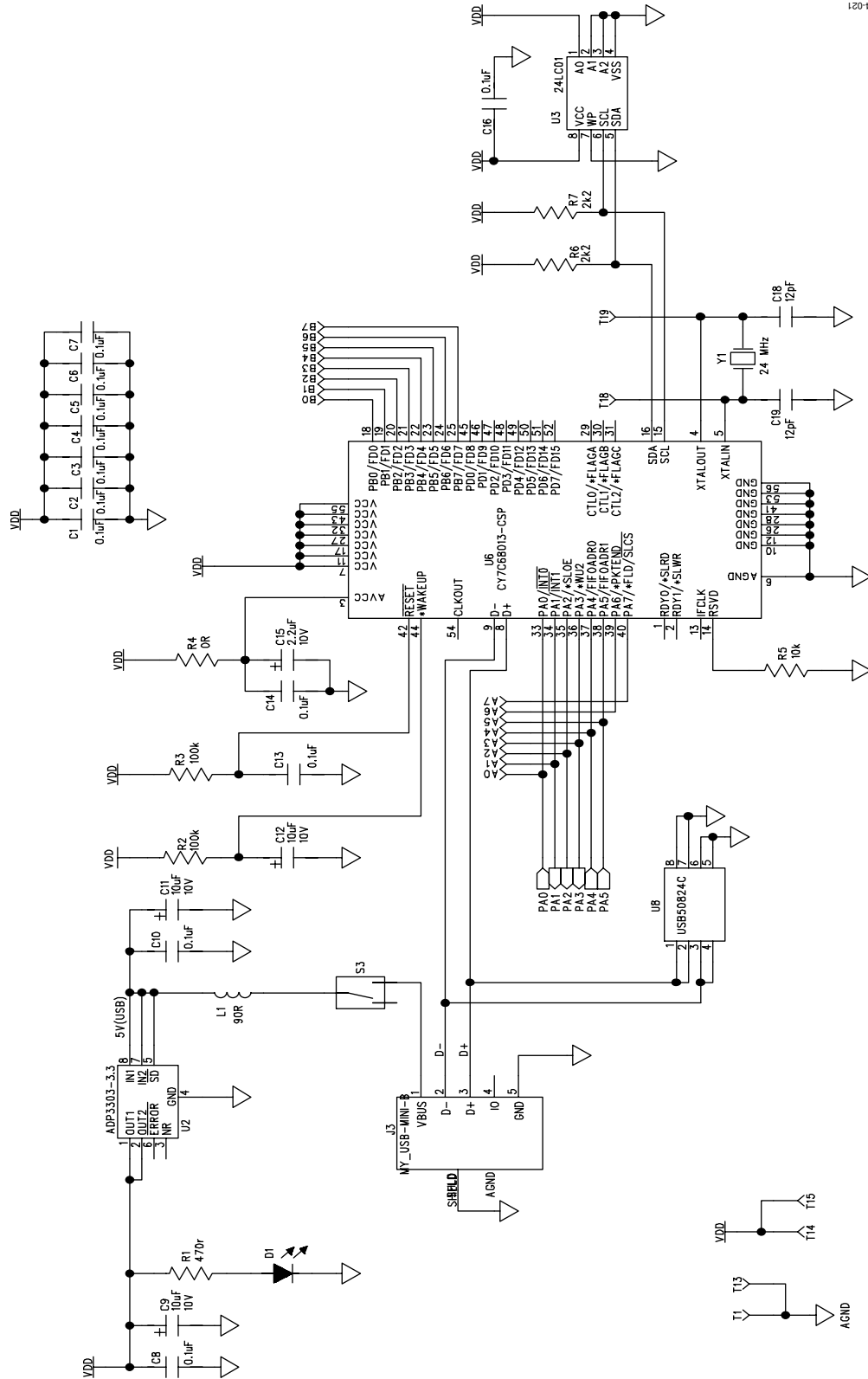

Figure 21. AD7147 Evaluation Board Schematic, USB Section