



Chipsmall Limited consists of a professional team with an average of over 10 year of expertise in the distribution of electronic components. Based in Hongkong, we have already established firm and mutual-benefit business relationships with customers from,Europe,America and south Asia,supplying obsolete and hard-to-find components to meet their specific needs.

With the principle of “Quality Parts,Customers Priority,Honest Operation,and Considerate Service”,our business mainly focus on the distribution of electronic components. Line cards we deal with include Microchip,ALPS,ROHM,Xilinx,Pulse,ON,Everlight and Freescale. Main products comprise IC,Modules,Potentiometer,IC Socket,Relay,Connector.Our parts cover such applications as commercial,industrial, and automotives areas.

We are looking forward to setting up business relationship with you and hope to provide you with the best service and solution. Let us make a better world for our industry!



Contact us

Tel: +86-755-8981 8866 Fax: +86-755-8427 6832

Email & Skype: info@chipsmall.com Web: www.chipsmall.com

Address: A1208, Overseas Decoration Building, #122 Zhenhua RD., Futian, Shenzhen, China



Evaluation Board for the AD7170 12-Bit, Low Power Sigma-Delta ADC

FEATURES

Full featured evaluation board for the [AD7170](#)

Standalone USB interface

Various linking options

PC software for control of the AD7170

GENERAL DESCRIPTION

This document describes the evaluation board for the AD7170, which is a very low power, 12-bit sigma-delta (Σ - Δ) ADC. It contains a precision 12-bit Σ - Δ ADC and has one differential input. The device has an output data rate of 125 Hz. It also has an on-board clock, eliminating the need for an external clock. Consuming only 135 μ A, the AD7170 is particularly suitable for portable or battery operated products where very low power is a requirement. The AD7170 also has a power-down mode in

which the device consumes 5 μ A, thus increasing the battery life of the product.

Full data on the AD7170 is available in the AD7170 data sheet available from Analog Devices, Inc., and should be consulted in conjunction with this data sheet when using the evaluation board.

The evaluation board interfaces to the USB port of an IBM®-compatible PC. Software is available with the evaluation board that allows users to easily communicate with the AD7170.

Note that the AD7170 evaluation board software should be installed before connecting the AD7170 evaluation board to the PC.

Another component on the AD7170 evaluation board is the [ADP3330](#) high precision, low power, 3.3 V output voltage regulator, which is used to power the USB/SPI interface.

FUNCTIONAL BLOCK DIAGRAM

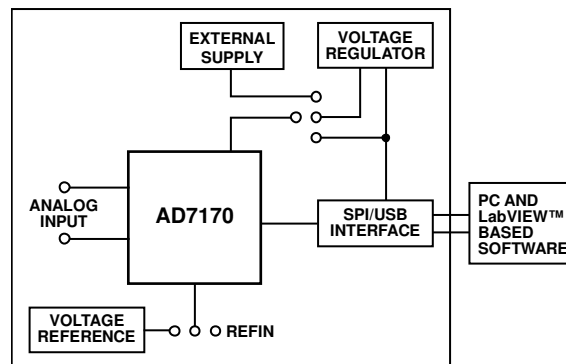

Figure 1.

08750-001

TABLE OF CONTENTS

Features	1	Evaluation Board Software.....	5
General Description	1	Software Description	5
Functional Block Diagram	1	Installing the Software.....	5
Revision History	2	Using the Software	5
Evaluation Board Hardware.....	3	Main Window	6
Power Supplies	3	Evaluation Board Schematic and Artwork.....	7
Links	3	Ordering Information.....	9
Setup Conditions	3	Bill of Materials.....	9
Sockets	3	ESD Caution.....	12
Interfacing to the Evaluation Board.....	4		

REVISION HISTORY

2/10—Revision 0: Initial Version

EVALUATION BOARD HARDWARE

POWER SUPPLIES

The AD7170 evaluation board is powered via the 5 V supply from the USB connector, J51. This 5 V supply can be used to power the AD7170 directly. A 3.3 V regulated voltage from the on-board ADP3330 (a high precision, low power, 3.3 V output voltage regulator) can also be used. Alternatively, the AD7170 can be powered using an external 3 V or 5 V power supply via J6.

LINKS

There are four groups of link options that must be set for the required operating setup before using the evaluation board. The functions of these link options are outlined in Table 1.

Table 1. Evaluation Board Link Settings

Link	Default	Description
J3, J7	IN	These links are used to connect the AIN(+) and AIN(−) inputs to AV _{DD} /2. With this configuration, a noise analysis can be performed. With these links removed, an external voltage can be applied to AIN using J4.
J8, AGND	AVDD, IN	AVDD can be used as the reference for the AD7170. With J8 in Position AVDD and Link AGND inserted, AVDD is connected to REFIN(+), and REFIN(−) is connected to AGND. With J8 in Position REF and Link AGND inserted, REFIN(+) is connected to the ADR391 (2.5 V), and REFIN(−) is connected to AGND. To use another reference source, remove the J8 and AGND links.
J1	3.3 V	J1 is used to select the power source for AV _{DD} on the AD7170. J1 in Position 3.3 V selects the 3.3 V regulated output from the onboard ADP3330 voltage regulator. J1 in Position 5 V selects the 5 V supply from the USB connector, J51. J1 in Position EXT selects an external power supply, supplied via J6.
J2	IN	These links connect the AD7170 serial interface pins to the SPI interface of the microcontroller. The links should be in place to use the AD7170 evaluation board software. With these links removed, the AD7170 can be interfaced to an external microcontroller.

Table 2. Initial Link and Switch Positions

Link	Position	Function
J3, J7	IN	AIN(+) and AIN(−) are shorted to AV _{DD} /2.
J8, AGND	AVDD, IN	The reference voltage is set to 3.3 V (AVDD).
J1	3.3 V	The 3.3 V supply is used as AV _{DD} for the AD7170.
J2	IN	The AD7170 is interfaced to the on-board microcontroller.

Table 3. Socket Functions

Socket	Description
J4	2-lead terminal block. An external analog signal can be connected to the analog input pins of the AD7170 using this terminal block.
J5	2-lead terminal block. An external reference source can be connected to the analog input pins of the AD7170 using this terminal block.
J6	2-lead terminal block. An external power supply can be used to supply the AD7170 using this terminal block.

SETUP CONDITIONS

Care should be taken before applying power and signals to the evaluation board to ensure that all link positions are set per the required operating mode. Table 2 shows the position in which all the links are initially set.

SOCKETS

Three sockets are relevant to the operation of the AD7170 on this evaluation board. The functions of these sockets are outlined in Table 3.

INTERFACING TO THE EVALUATION BOARD

Interface to the evaluation board is via a standard USB connector, J51, which connects the evaluation board to the USB port of a PC. A standard USB connector cable is included with the [AD7170](#) evaluation board to connect it to the USB port of the PC. Because the board is powered via the USB connector, there is no need for an external power supply, although if preferred, one can be connected via J6.

Communication between the AD7170 and the PC is via the USB/SPI interface. The on-board USB controller (U2) handles this communication.

To set up the USB/SPI interface, use the following procedure:

1. Install the AD7170 evaluation board software using the supplied AD7170 evaluation board CD before connecting the board to the PC.
2. After the AD7170 evaluation board software is installed, connect the board to the PC via J1 on the AD7170 evaluation board and via the USB port on the PC using the supplied USB connector cable. The PC automatically finds the new USB device and identifies it as the **AD779x Evaluation Board**.
3. Follow the on-screen instructions that appear. During the installation process, if the **Hardware Installation** window appears as shown in Figure 2, click **Continue Anyway** to complete the installation of the AD7170 evaluation board.



Figure 2. Hardware Installation Window

08750-002

EVALUATION BOARD SOFTWARE

SOFTWARE DESCRIPTION

The AD7170 evaluation board is shipped with a CD containing software that can be installed onto a standard PC to control the AD7170. The software communicates with the AD7170 through the USB cable, which accompanies the board. The software allows you to configure the AD7170 and to read conversion data from the AD7170. Data can be read from the AD7170 and displayed or stored for later analysis. For further information, see the AD7170 data sheet available from Analog Devices.

INSTALLATING THE SOFTWARE

Use the following steps to install the software:

1. Start Windows® and insert the CD.
2. The installation software should launch automatically. If it does not, use Windows Explorer to locate the **setup.exe** file on the CD. Double-click this file to start the installation procedure.

3. At the prompt, select a destination directory, which is **C:\Program Files\Analog Devices\AD7170** by default. Once the directory is selected, the installation procedure copies the files into the relevant directories on the hard drive. The installation program creates a program group called **Analog Devices** with the subgroup **AD7170** in the **Start** menu of the taskbar.
4. Once the installation procedure is complete, double-click the **AD7170** icon to start the program.

USING THE SOFTWARE

Figure 3 shows the main window that is displayed when the program starts. The Main Window section briefly describes the various menu and button options in the main window.

The data that is read can be exported to other packages, such as MathCAD™ or Microsoft® Excel, for further analysis.

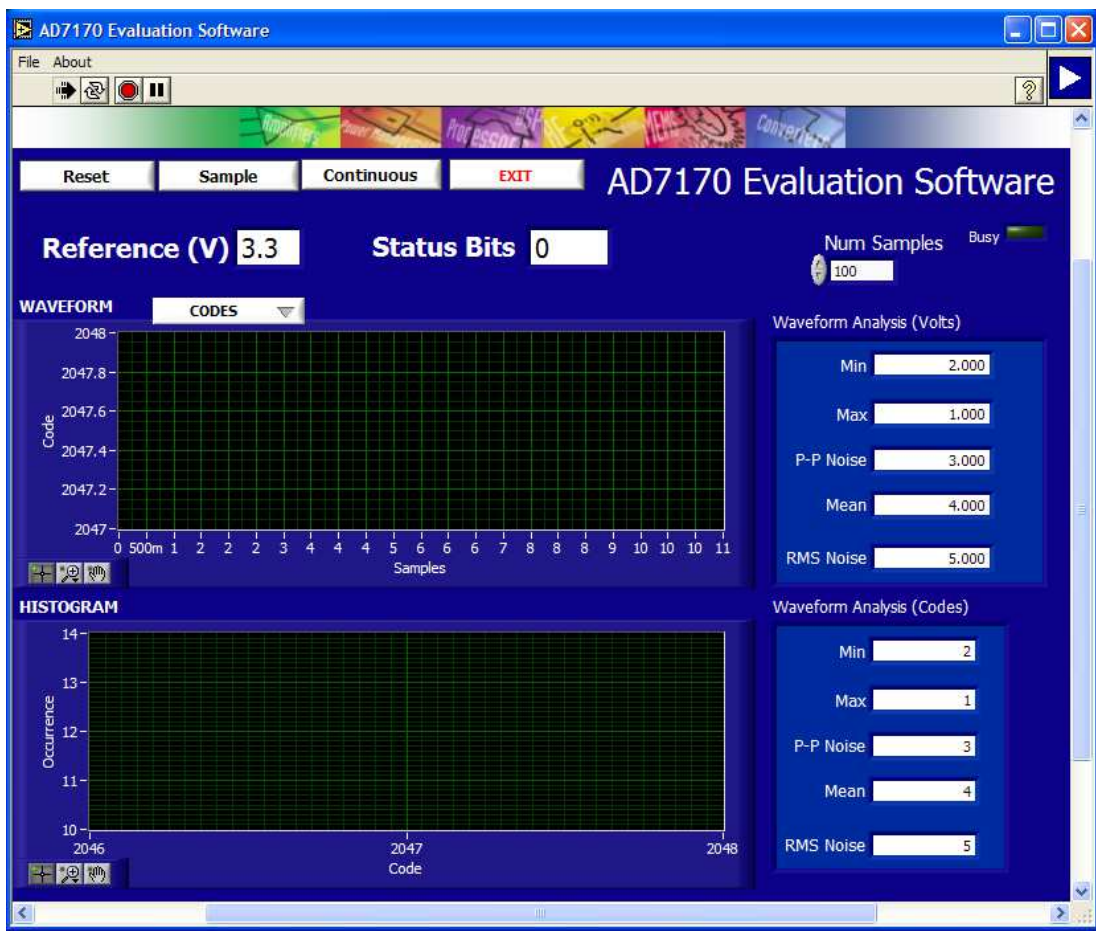

Figure 3. AD7170 Evaluation Software Main Window

MAIN WINDOW

Menu Bar

File

This allows the user to read previously stored data for display or analysis, write the current set of data to a file for later use, and exit the program.

About

This provides revision information about the application.

Buttons

Reset

This allows the user to reset the [AD7170](#) software.

Exit

This allows the user to exit the software. It serves the same purpose as **Quit** in the **File** pull-down menu.

Sample

This allows the user to read a number of samples from the AD7170. Noise analysis is then performed on the samples. These samples can be stored for further analysis. The sample size is entered in the **Num Samples** text box.

Continuous

This allows the user to read a number of samples continuously. The software gathers a number of samples as specified by the **Num Samples** text box, performs noise analysis on the samples, and gathers the next group of samples.

Reference

The value of the external reference should be displayed in the **Reference (V)** text box.

Status Bits

This box displays the contents of the status register.

Waveform

The gathered conversions are displayed in graph form.

Codes/Volts

The gathered samples can be displayed in codes or in voltage format. When the **CODES** option is selected, the values are displayed as code. To display the information in volts, select the **VOLTS** option.

Histogram

The gathered samples are used to generate a histogram.

Waveform Analysis (Volts)

The gathered samples are processed, and the minimum conversion, maximum conversion, average conversion, p-p noise and rms noise are displayed in volts.

Waveform Analysis (Codes)

The gathered samples are processed, and the minimum conversion, maximum conversion, average conversion, p-p noise and rms noise are displayed in codes.

EVALUATION BOARD SCHEMATIC AND ARTWORK

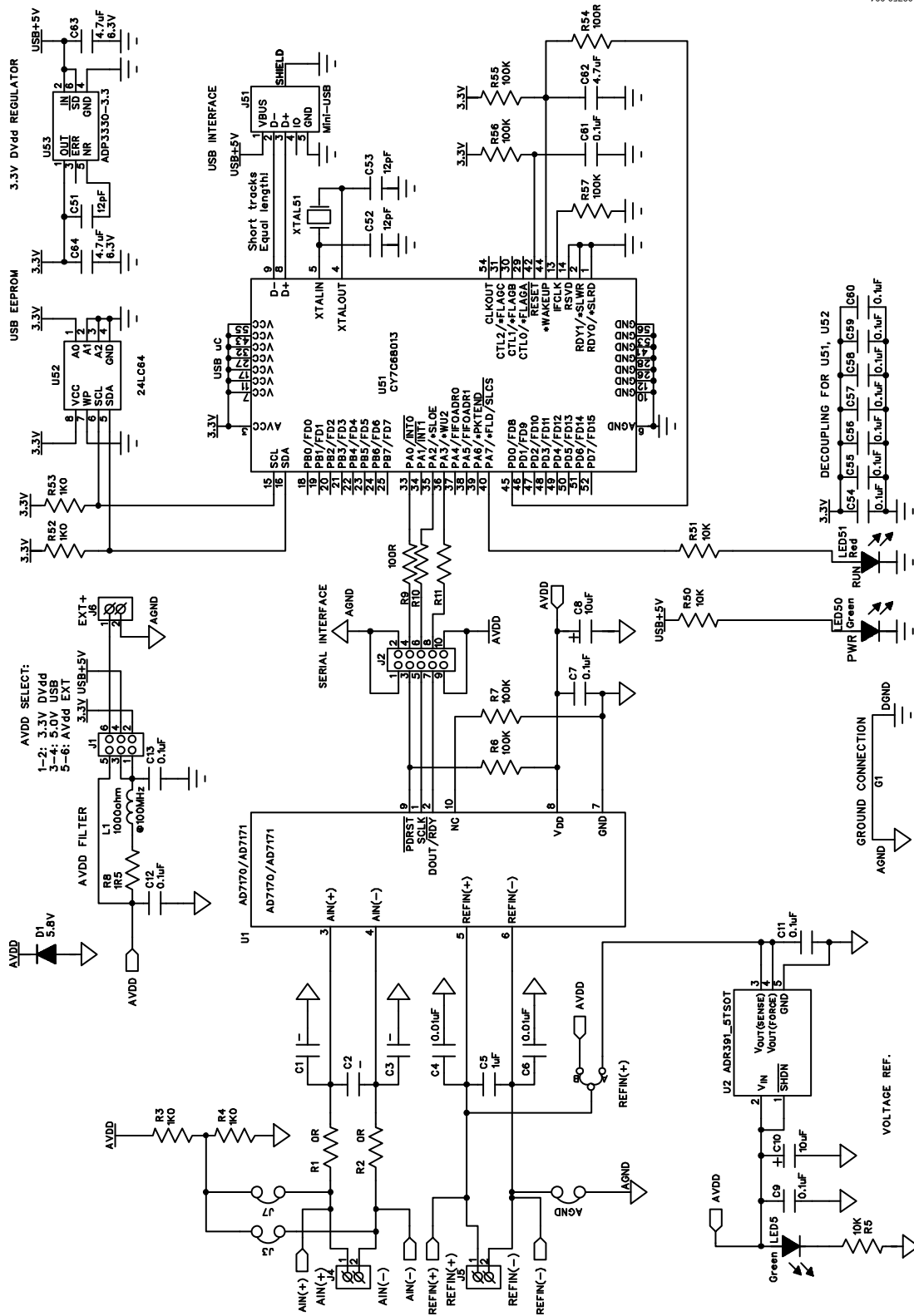

900-957-80

Figure 4. AD7170 Evaluation Board Schematic

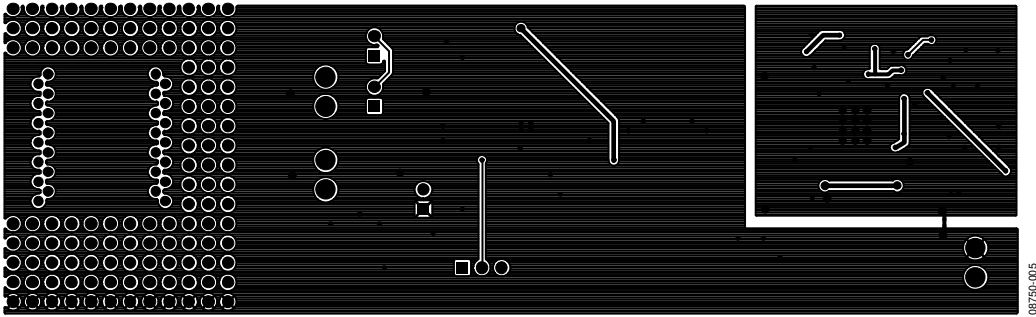

Figure 5. AD7170 Evaluation Board—Solder Side View

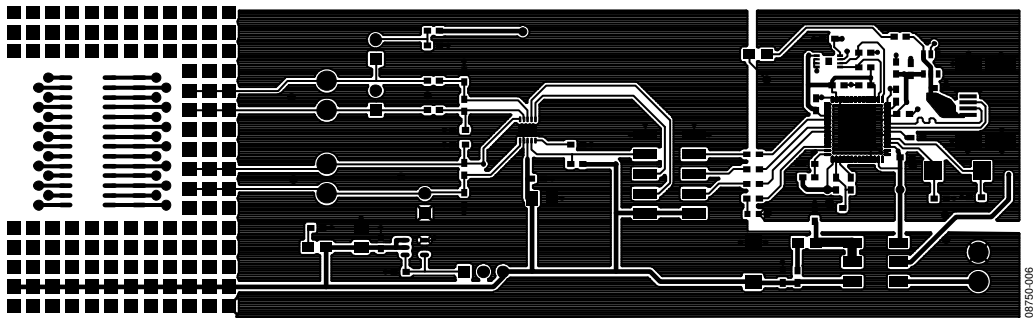

Figure 6. AD7170 Evaluation Board—Component Side View

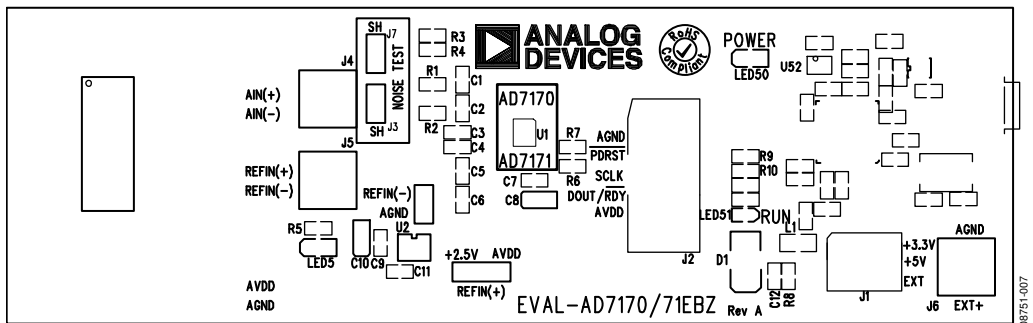

Figure 7. AD7170 Evaluation Board—Component Layout Diagram

ORDERING INFORMATION

BILL OF MATERIALS

Table 4.

Reference Designator	Description	Manufacturer	Part Number
Integrated circuits			
U1		Analog Devices	AD7170BCPZ
U2		Analog Devices	ADR391AUJZ
U51	USB controller	Cypress Semiconductor Corporation	CY7C68013A-56LFXC
U52	24LC64	Microchip Technology, Inc.	24LC64-I/SN
U53		Analog Devices	ADP3330ARZ-3.3
XTAL51	24 MHz crystal	AEL Crystals	X24M0000005244
LED5, LED50, LED51	Green LED	Kingbright, Elec. Co., Ltd	KP-2012SGC
L1	Ferrite bead	Tyco Electronics	BMB2A0300AN1
D1	Diode	Micro Commercial Components Corp.	DL4001-TP
Capacitors			
C1 to C3	Capacitors		Not inserted
C4, C6	10 nF ceramic	Phycomp	223858615636
C5	1 μ F ceramic	Phycomp	223878615649
C7, C9, C11, C12, C13, C54 to C61	0.1 μ F \pm 10% ceramic	Phycomp	223878615649
C8, C10	10 μ F tantalum	AVX Corporation	TAJA106M016R
C51, C52, C53	12 pF ceramic	Phycomp	223886715129
C62, C63, C64	4.7 μ F ceramic	Phycomp	225520613672
Resistors			
R1, R2	0 Ω resistor	Phycomp	232270296001
R3, R4, R52, R53	1 k Ω resistor	Phycomp	RC0603FR-071KL
R5, R50, R51	10 k Ω resistor	Phycomp	RC0603FR-0710KL
R6, R7, R55, R56, R57	100 k Ω resistor	Phycomp	RC0603FR-07100KL
R8	1.5 Ω resistor	Phycomp	RC0603FR-071R5L
R9, R10, R11, R54	100 Ω resistor	Phycomp	RC0603FR-07100RL
Links			
J3, J7, AGND (2 \times 1 way)	Pin headers	Harwin Plc	M20-9990246
J8 (3 \times 1 way)	Pin headers	Harwin Plc	M20-9990246
J1 (3 \times 2 way)	Pin headers	Tyco Electronics	1241050-3
J2 (5 \times 3 way)	Pin headers	Tyco Electronics	1241050-5
At J1, J2, J3, J7, AGND, J8	Shorting plugs	Harwin Plc	M7566-05
Connectors			
J51	USB Mini-B connector	Molex	565790576
J4, J5, J6	2-way terminal block	Phoenix Contact	1727010

NOTES

NOTES

NOTES

ESD CAUTION**ESD (electrostatic discharge) sensitive device.**

Charged devices and circuit boards can discharge without detection. Although this product features patented or proprietary protection circuitry, damage may occur on devices subjected to high energy ESD. Therefore, proper ESD precautions should be taken to avoid performance degradation or loss of functionality.

Evaluation boards are only intended for device evaluation and not for production purposes. Evaluation boards are supplied "as is" and without warranties of any kind, express, implied, or statutory including, but not limited to, any implied warranty of merchantability or fitness for a particular purpose. No license is granted by implication or otherwise under any patents or other intellectual property by application or use of evaluation boards. Information furnished by Analog Devices is believed to be accurate and reliable. However, no responsibility is assumed by Analog Devices for its use, nor for any infringements of patents or other rights of third parties that may result from its use. Analog Devices reserves the right to change devices or specifications at any time without notice. Trademarks and registered trademarks are the property of their respective owners. Evaluation boards are not authorized to be used in life support devices or systems.

©2010 Analog Devices, Inc. All rights reserved. Trademarks and registered trademarks are the property of their respective owners.
UG08750-0-2/10(0)



www.analog.com