



Chipsmall Limited consists of a professional team with an average of over 10 year of expertise in the distribution of electronic components. Based in Hongkong, we have already established firm and mutual-benefit business relationships with customers from,Europe,America and south Asia,supplying obsolete and hard-to-find components to meet their specific needs.

With the principle of “Quality Parts,Customers Priority,Honest Operation,and Considerate Service”,our business mainly focus on the distribution of electronic components. Line cards we deal with include Microchip,ALPS,ROHM,Xilinx,Pulse,ON,Everlight and Freescale. Main products comprise IC,Modules,Potentiometer,IC Socket,Relay,Connector.Our parts cover such applications as commercial,industrial, and automotives areas.

We are looking forward to setting up business relationship with you and hope to provide you with the best service and solution. Let us make a better world for our industry!



Contact us

Tel: +86-755-8981 8866 Fax: +86-755-8427 6832

Email & Skype: info@chipsmall.com Web: www.chipsmall.com

Address: A1208, Overseas Decoration Building, #122 Zhenhua RD., Futian, Shenzhen, China



FEATURES

Full featured evaluation board for the [AD7329](#)
 EVAL-CONTROL-BRD2 compatible
 Standalone capability
 Various linking options

INTRODUCTION

This data sheet describes the evaluation board for the AD7329, which is a software-selectable, bipolar input 13-bit ADC. This part operates from a single 2.7 V to 5.25 V and dual ± 12 V power supply, and features throughput rates of up to 1 MSPS. Refer to the [AD7329](#) data sheet available for full data on the part. Consult the [AD7329](#) data sheet in conjunction with this data sheet when using the evaluation board.

On-board components include the [AD780](#), which is a pin-programmable 2.5 V or 3 V ultrahigh, precision band gap reference, and the [AD797](#) op amp.

FUNCTIONAL BLOCK DIAGRAM

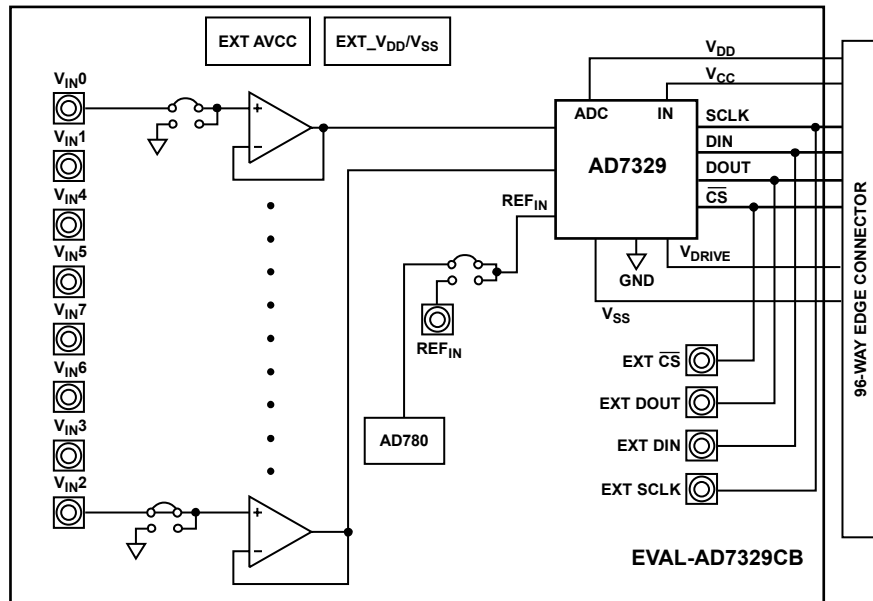

Figure 1.

Rev. 0

Evaluation boards are only intended for device evaluation and not for production purposes. Evaluation boards as supplied "as is" and without warranties of any kind, express, implied, or statutory including, but not limited to, any implied warranty of merchantability or fitness for a particular purpose. No license is granted by implication or otherwise under any patents or other intellectual property by application or use of evaluation boards. Information furnished by Analog Devices is believed to be accurate and reliable. However, no responsibility is assumed by Analog Devices for its use, nor for any infringements of patents or other rights of third parties that may result from its use. Analog Devices reserves the right to change devices or specifications at any time without notice. Trademarks and registered trademarks are the property of their respective owners. Evaluation boards are not authorized to be used in life support devices or systems.

TABLE OF CONTENTS

Features	1	Evaluation Board Software.....	7
Introduction	1	AD7329 Software	7
Functional Block Diagram	1	Software Description	7
Revision History	2	Setting Up the EVAL-CONTROL-BRD2.....	9
Evaluation Board Hardware.....	3	Software Configuration Files	9
Operating the AD7329 Evaluation Board	3	Configuring the Analog Inputs for Single-Ended and Differential Operation	9
Link Options	3	Evaluation Board Schematics.....	10
Setup Conditions	3	Ordering Information.....	13
Evaluation Board Interfacing.....	5	Ordering Guide	13
Sockets	6	ESD Caution.....	13
Operating with the EVAL-CONTROL-BRD2.....	6		

REVISION HISTORY

2/07—Revision 0: Initial Version

EVALUATION BOARD HARDWARE

OPERATING THE AD7329 EVALUATION BOARD

Power Supplies

When using this evaluation board with the EVAL-CONTROL-BRD2, all supplies are provided from the controller board through the 96-way connector.

When using the board as a standalone unit, external supplies must be provided. This evaluation board has five power supply inputs: EXT_V_{DD}, AGND, +12 V, -12 V, and AGND. If the evaluation board is used in standalone mode, a 2.7 V to 5.25 V supply must be connected to the EXT_V_{DD} input. The +12 V and -12 V supplies are required for the high voltage analog input section on the AD7329 and the AD797 op amps. The supplies are decoupled to the ground plane with 10 μ F tantalum and 0.1 μ F multilayer ceramic capacitors at the point where they enter the board. The supply pins of the op amps and the reference are also decoupled with 10 μ F tantalum and 0.1 μ F ceramic capacitors, as are Pin V_{DD}, Pin V_{SS}, and Pin V_{CC} of the AD7329.

LINK OPTIONS

There are 26 link options that must be set for the required operating setup before using the evaluation board. The functions of the options are outlined in Table 1.

SETUP CONDITIONS

Care should be taken before applying power and signals to the evaluation board to ensure that all link positions are as per the required operating mode.

Table 2 shows the position in which the links are set when the evaluation board is packaged.

Table 1.

Link No.	Function
LK1	This link option controls the program pin of the AD780 voltage reference.
LK2	This link selects the source of the REF _{IN} voltage to be applied to the REF _{IN} pin of the AD7329. When in Position A, the AD780 supplies the 2.5 V reference to the AD7329. When in Position B, the REF _{IN} is supplied through the J4 SMB connector.
LK3	This link selects the source of the V _{CC} supply for the AD7329. When in Position A, the V _{CC} supply is taken from the 96-way connector of the EVAL-CONTROL-BRD2. When in Position B, the V _{CC} supply is taken from the external J2 connector.
LK4	This link option selects the source of the V _{DRIVE} voltage for the AD7329. When in Position A, the V _{DRIVE} voltage is taken from the external J3 V _{DRIVE} socket. When in Position B, the V _{DRIVE} voltage is taken from the 96-way connector of the EVAL-CONTROL-BRD2. When in Position C, the V _{DRIVE} voltage is tied to the V _{CC} voltage.
LK5	This link option selects the source of the $\overline{\text{CS}}$ signal. When in Position A, the $\overline{\text{CS}}$ signal is taken from the 96-way connector of the EVAL-CONTROL-BRD2. When in Position B, the $\overline{\text{CS}}$ signal is taken from the J5 $\overline{\text{CS}}$ SMB socket.
LK6	This link selects the source of the SCLK signal for the AD7329. When in Position A, the SCLK signal comes from the J6 SMB socket. When in Position B, the SCLK signal comes from the 7504 inverter, which is an inverted SCLK signal from the 96-way connector. When in Position C, the SCLK signal is taken directly from EVAL-CONTROL-BRD2 through the 96-way connector.
LK7	This link option selects the source of the DIN signal to the AD7329. When in Position A, the DIN signal is taken from the 96-way connector to the EVAL-CONTROL-BRD2. When in Position B, the DIN signal is taken from the J7 DIN SMB socket.
LK8	This link option selects the destination of the DOUT signal from the AD7329. When in Position A, the DOUT signal goes to the 96-way connector to the EVAL-CONTROL-BRD2. When in Position B, the DOUT signal goes to the DOUT J8 SMB socket.
LK9, LK11, LK13, LK15, LK17, LK19, LK21, LK23	These link options add a 51 Ω termination resistor to AGND at the V _{IN0} to V _{IN7} input sockets.
LK10, LK12, LK14, LK16, LK18, LK20, LK22, LK24	These link options select the input to the AD797 op amp. When in Position A, the AD797 noninverting input is tied to the SMB socket. When in Position B, the AD797 noninverting input is tied to AGND.
LK25	This link option is used to select the source of the 12 V supply for the EVAL-AD7329CB. When in Position A, the 12 V supply is sourced from the EVAL-CONTROL-BRD2 via the 96-way connector. When in Position B, the 12 V supply is sourced externally via the J17 connector.

EVAL-AD7329CB

Link No.	Function
LK26	This link option is used to select the source of the -12 V supply for the EVAL-AD7329CB. When in Position A, the -12 V supply is sourced from the EVAL-CONTROL-BRD2 via the 96-way connector. When in Position B, the -12 V supply is sourced externally via the J17 connector.
LK27	This link option is used to select the configuration of the noninverting input to U5. The configuration of this link depends on whether the board is being used in single-ended or differential mode. For single-ended mode, this link should be inserted. For true differential mode, this link should be removed.
LK28	This link option is used to select the configuration of the noninverting input to U9. The configuration of this link depends on whether the board is being used in single-ended or differential mode. For single-ended mode, this link should be inserted. For true differential mode, this link should be removed.
LK29	This link option is used to select the configuration of the noninverting input to U7. The configuration of this link depends on whether the board is being used in single-ended or differential mode. For single-ended mode, this link should be inserted. For true differential mode, this link should be removed.
LK30	This link option is used to select the configuration of the noninverting input to U11. The configuration of this link depends on whether the board is being used in single-ended or differential mode. For single-ended mode, this link should be inserted. For true differential mode, this link should be removed.
SL1 to SL4	These solder link options can be inserted for differential mode.
LK31	This link option connects the MUX _{OUT+} pin to the ADC _{IN+} pin. When no circuitry is being placed between the mux output and the ADC input, this link should be inserted.
LK32	This link option connected the MUX _{OUT-} pin to the ADC _{IN-} pin. When no circuitry is being placed between the mux output and the ADC input, this link should be inserted. In differential mode, this link should also be inserted.
LK33	This link is used to connect the J19 socket to the MUX _{OUT+} pin.
LK34	In addition to LK33, when LK34 is inserted, the MUX _{OUT+} pin is connected to the input of U13.
LK35	This link is used to connect the J21 socket or the input of U12 to the MUX _{OUT-} pin.
LK36	In addition to LK35, this link option is used to connect the MUX _{OUT-} pin to the input of U12.
LK37	This link option is used to connect the ADC _{IN-} pin to ground. This should be inserted in Single ended mode.
LK38	This link option, in addition to LK36 and LK35, is used to connect the MUX _{OUT-} pin to ground. This should be inserted for single-ended mode.

Table 2. Initial Link Positions

Link No.	Position	Function
LK1	Out	The AD780 supplies a 2.5 V reference to the AD7329.
LK2	A	The AD780 supplies the reference to the AD7329.
LK3	A	The V_{CC} supply is taken from the EVAL-CONTROL-BRD2.
LK4	C	The V_{DRIVE} supply is taken from the V_{CC} supply.
LK5	A	The \overline{CS} signal is taken from the EVAL-CONTROL-BRD2.
LK6	C	The SCLK signal is taken from the EVAL-CONTROL-BRD2.
LK7	A	The DIN signal is taken from the EVAL-CONTROL-BRD2.
LK8	A	The DOUT signal is sent to the EVAL-CONTROL-BRD2.
LK9, LK11, LK13, LK15, LK17, LK19, LK21, LK23	Out	No 51 V termination on the inputs.
LK10	A	V_{IN0} SMB connected to input of AD797.
LK12, LK14, LK16, LK18, LK20, LK22, LK24	B	Inputs to AD797 set to AGND.
LK25	A	+12 V is supplied from the EVAL-CONTROL-BRD2.
LK26	A	-12 V is supplied from the EVAL-CONTROL-BRD2.
LK27 to LK30	Inserted	-12 V is supplied from the EVAL-CONTROL-BRD2.
LK31	Inserted	Connects MUX _{OUT+} to ADC _{IN+} .
LK32	Inserted	Connects MUX _{OUT-} to ADC _{IN-} .
LK33 to LK36, LK38	Out	No connection to J19 and J21.
LK37	Inserted	Connects ADC _{IN-} and MUX _{OUT-} to ground.
SL1 to SL4	Out	Inputs configured for single-ended mode.

EVALUATION BOARD INTERFACING

Interfacing to the evaluation board is via a 96-way connector, J1. J1 is used to connect the EVAL-AD7329CB evaluation board to the EVAL-CONTROL-BRD2 or another system. The pinout for the J1 connector is shown in Figure 2 and its pin designations are given in Table 4.

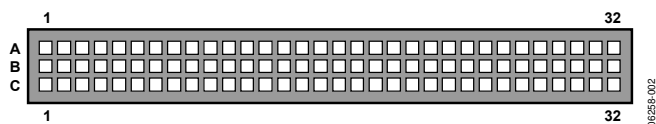

Figure 2. Pin Configuration for the 96-Way Connector, J1

Table 3.

Signal	Description
TFS0, RFS0	Transmit/Receive Frame Sync 0. These two outputs are connected to the \overline{CS} pin of the AD7329.
SCLK0	Serial Clock 0. This serial clock is connected to the SCLK pin on the AD7329.
DR0	Data Receive 0. This input is connected to the DOUT pin of the AD7329.
DT0	Data Transmit 0. This output is connected to the DIN pin on the AD7329.
AGND	Analog Ground. These lines are connected to the analog ground plane on the evaluation board.
DGND	Digital Ground. These lines are connected to the digital ground plane on the evaluation board.
AVDD	Analog 5 V Supply. These lines are connected to the V_{CC} supply line on the board via LK3.
-12 V	-12 V Supply. This line is connected to the -12 V supply line on the board via LK26.
+12 V	+12 V Supply. This line is connected to the +12 V supply line on the board via LK25.

Table 4. Pin Designations for 96-Way Connector, J1¹

Pin No.	Row A	Row B	Row C
1			
2			
3			
4	DGND	DGND	DGND
5	DT0		DR0
6	TFS0		RFS0
7	SCLK0		
8	DVDD	DVDD	DVDD
9			
10			
11			
12	DGND	DGND	DGND
13			
14			
15			
16	DGND	DGND	DGND
17			
18			
19			
20	DGND	DGND	DGND
21	AGND	AGND	AGND
22	AGND	AGND	AGND
23	AGND	AGND	AGND
24	AGND	AGND	AGND
25	AGND	AGND	AGND
26	AGND	AGND	AGND
27		AGND	
28		AGND	
29		AGND	
30	-12 V	AGND	+12 V
31			
32	AVDD	AVDD	AVDD

¹ The unused pins of the 96-way connector are not shown.

EVAL-AD7329CB

SOCKETS

There are 17 input/output sockets relevant to the operation of the AD7329 on this evaluation board. The functions of these sockets are outlined in Table 5.

Table 5.

Socket	Function
J1	96-way connector for serial interface and power supply connections
J2	External V_{CC} and AGND power connector
J3	External V_{DRIVE} connector
J17	External +12 V, -12 V, and AGND power connector
V_{IN0} to V_{IN7}	8 SMB sockets for bipolar input signal to op amps
J18 to J21	Options to add external signals to mux
REF_{IN}	SMB socket for REF_{IN} voltage
SCLK	SMB socket for external SCLK input
\overline{CS}	SMB socket for an external \overline{CS} input
DOUT	SMB socket for DOUT signal
DIN	SMB socket for external DIN signal

OPERATING WITH THE EVAL-CONTROL-BRD2

The evaluation board operates in a standalone mode or in conjunction with the EVAL-CONTROL-BRD2. This EVAL-CONTROL-BRD2 is available from Analog Devices, Inc. under the order entry EVAL-CONTROL-BRD2. All supplies and control signals to operate the AD7329 are provided by the EVAL-CONTROL-BRD2 when it is run under the control of the AD7329 software that is provided with the AD7329 evaluation board package. This EVAL-CONTROL-BRD2 also operates with all Analog Devices evaluation boards with the letters CB in their titles.

The 96-way connector on the EVAL-AD7329CB plugs directly into the EVAL-CONTROL-BRD2. No power supplies are required in the system. The EVAL-CONTROL-BRD2 generates the required supplies for itself and the EVAL-AD7329CB. The EVAL-CONTROL-BRD2 is powered from a 12 V ac transformer. This is a standard 12 V ac transformer capable of supplying 1 A current and is available as an accessory from Analog Devices under the part numbers found in Table 6.

Table 6.

12 V AC Supply	For Use In
EVAL-110VAC-US	United States or Japan
EVAL-220VAC-UK	United Kingdom
EVAL-220VAC-EU	Europe

These transformers are also available from other suppliers including Digi-Key (United States) and Campbell Collins (United Kingdom).

Connection between the EVAL-CONTROL-BRD2 and the parallel port of a PC is via an IEEE 1284-compliant cable that is provided as part of the EVAL-CONTROL-BRD2 package. For more details, refer to the manual that accompanies the EVAL-CONTROL-BRD2 package.

EVALUATION BOARD SOFTWARE

AD7329 SOFTWARE

Included in the EVAL-AD7329CB evaluation kit is a CD that contains software for controlling and evaluating the performance of the AD7329 when it is operated with the EVAL-CONTROL-BRD2. Insert the CD to automatically begin the installation program. This program installs the evaluation software onto the user's machine, and it also installs the data sheets for this evaluation board, the AD7329, and the EVAL-CONTROL-BRD2. All literature on the CD is in PDF and requires Adobe Acrobat Reader® to be viewed or printed. The user interface on the PC is a dedicated program written especially for the AD7329 when operated with the EVAL-CONTROL-BRD2.

SOFTWARE DESCRIPTION

The software that controls the EVAL-CONTROL-BRD2, and therefore the AD7329, has two main dialog boxes. The dialog box shown in Figure 3 appears when the software is run. The main function of this dialog box is to allow the user to read a predetermined number of samples from the evaluation board and display them in both the time and frequency domain. The dialog box can be divided into three sections.

The upper third of the dialog box contains the control buttons, the menu bar, the busy status, and the selection windows. The control buttons allow users to:

- Take samples (**Sample**)
- **Reset** the board
- **EXIT** the program
- Click **Device Select** to open the **Load Configuration** dialog box (see Figure 4) and to load a configuration file.

The menu bar consists of **File** and **About**. The **File** menu allows the following:

- **Load Raw Data:** Selecting this option allows the user to load data that has been saved by the software during a previous session.
- **Save Raw Data:** Selecting this option allows the user to save the current set of sample data points. The data can be reloaded to the EVAL-CONTROL-BRD2 at a later date or can be used by other programs for further analysis.
- **Save Binary Data:** Selecting this option allows the user to save the current set of sample data points. The data is saved in binary format as a text file. This method can be useful for examining code flicker and looking for stuck bits.
- **EXIT:** Quits the program.

The **About** drop-down menu gives the user information about the version of the software.

The **Busy Status** indicates to the user when the evaluation board is busy.

The selection's window allows the user to change the sampling **Frequency** and the number of samples (**Num Samples**) to upload (see Figure 3).

The middle third of the dialog box is a digital storage oscilloscope (DSO) that allows the user to display either a **Waveform**, a **Histogram**, or an **FFT**. When samples are uploaded from the EVAL-CONTROL-BRD2, they are displayed here (see Figure 3). At the bottom left of the graph are the zoom options. These allow the user to zoom in and out to get a closer look at a sample, if required. The right-hand side of the middle section contains information about the samples taken such as minimum (**Min**)/maximum (**Max**) position or velocity, the **Spread**, the **Mean**, and the standard deviation (**Std. Dev**).

The lower third of the dialog box is also a DSO that allows the user to display either a **Waveform**, a **Histogram**, or an **FFT**. The **FFT** (the default option) is typically used when the user is concerned with examining the performance in the frequency domain, and the **Histogram** gives an indication of the performance in response to dc inputs. The option displayed can be changed by clicking the **Waveform**, **Histogram**, and **FFT** buttons. The right-hand side of the lower section contains information about the samples taken, for example, ac specifications (see Figure 3).

Load Configuration Dialog Box

The **Load Configuration** dialog box allows users to load the required configuration file for the evaluation board (see Figure 4). The configuration file gives the software detailed information about the AD7329 evaluation board, and the part connected to the EVAL-CONTROL-BRD2, such as the number of bits (**Num Bits**), the maximum sampling rate (**Max Sample Frequency**), the output coding, and the power supply requirements. The configuration file also tells the software the names of the DSP program file that it should download to the EVAL-CONTROL-BRD2. The **Load Configuration** dialog box also allows the user to choose the sampling frequency (**Sample Frequency**) and the number of samples (**Num Samples**) to take.

EVAL-AD7329CB

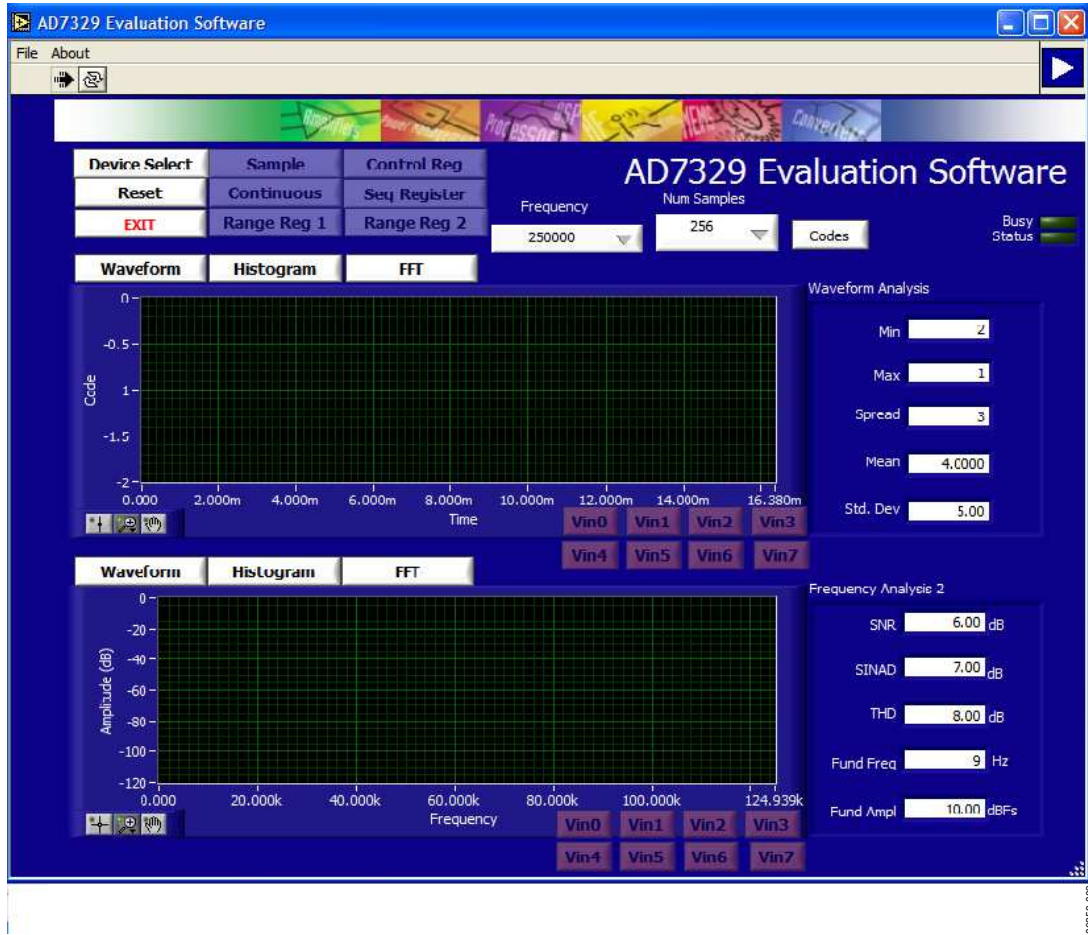

Figure 3. AD7329 Evaluation Software, Main Dialog Box



Figure 4. AD7329 Evaluation Software, Load Configuration Dialog Box

SETTING UP THE EVAL-CONTROL-BRD2

This section describes how the evaluation board, the EVAL-CONTROL-BRD2, and the software should be set up for the user to begin using the complete system.

The EVAL-CONTROL-BRD2 and evaluation board should be connected together (via the 96-way connector). The power should be applied to the EVAL-CONTROL-BRD2 via a 12 V ac transformer. At this stage, the red LED on the EVAL-CONTROL-BRD2 should be flashing, which indicates that the EVAL-CONTROL-BRD2 is functional and ready to receive instructions. The software should be loaded before the printer port cable is connected between the EVAL-CONTROL-BRD2 and the PC. This ensures that the printer port is initialized properly. The printer port can then be connected between the PC and the EVAL-CONTROL-BRD2.

Running the Software

With the hardware set up, the user can now use the software to control the EVAL-CONTROL-BRD2 and the AD7329 evaluation board.

When running the software, click the **Device Select** button. This displays the **Load Configuration** dialog box (as shown in Figure 4). The **Select a Configuration File:** list located on the top left of the **Load Configuration** dialog box lists the available configuration files. The configuration files are text-based files that contain information about the particular evaluation board to be tested. The file covers the **Part Name**, number of samples (**Num Samples**) to be taken, number of bits (**Num Bits**), default and maximum sampling frequency (**Sample Frequency** and **Max Sample Frequency**), power supply settings (**Input V Max** and **Input V Min**), and **Data Format**. The configuration file also contains the names of the DSP code *.prg that is to be downloaded to the EVAL-CONTROL-BRD2. The user should select the relevant configuration file and click **OK**. The EVAL-CONTROL-BRD2 is reset, and the DSP program is downloaded. When the download is completed, the power supply settings indicated in the configuration file are set, and the user may hear some of the relays clicking. The selection windows (for example, **Num Samples** and **Sample Frequency**) is set to the default values specified by the configuration file. However, the user is free to change these at will.

Taking Samples

When the user clicks **Sample**, the software instructs the EVAL-CONTROL-BRD2 to take the required number of samples at the required frequency from the evaluation board.

The samples taken are then uploaded and displayed. An FFT and histogram are also calculated and displayed. If the user clicks **Continuous**, the software repeats the process indefinitely until the user clicks **Stop**.

SOFTWARE CONFIGURATION FILES

Software configuration files give the EVAL-CONTROL-BRD2 software information on how the software and hardware should perform. They contain information such as the name of the DSP program to download, the default and maximum sample frequencies, the number of samples to take, and the power supply settings to use. A typical software configuration file (*.cfg) follows.

```
[EVAL-CONTROL BOARD]
partname:AD7329
programname:AD7329.PRG
samplefrequency:1000000
maxsamplefrequency:1000000
samples:2048
+/-12V:on
dvdd:5:on
avdd:5:on
bus:on
;options 2scomp, binary
dataformat:2scomp
numberofbits:13
inputVmax:+10V
inputVmin:-10V
[endofconfig]
```

CONFIGURING THE ANALOG INPUTS FOR SINGLE-ENDED AND DIFFERENTIAL OPERATION

To select between single-ended and differential operation, click the **Control Reg** button in the main dialog box and set the **Mode1** bit and **Mode0** bit according to the [AD7329](#) data sheet. The power-up default setting is single-ended mode, and the analog input on the evaluation board is set for this mode. Figure 5 shows the **Control Reg** setup for true differential mode.



Figure 5.

EVALUATION BOARD SCHEMATICS

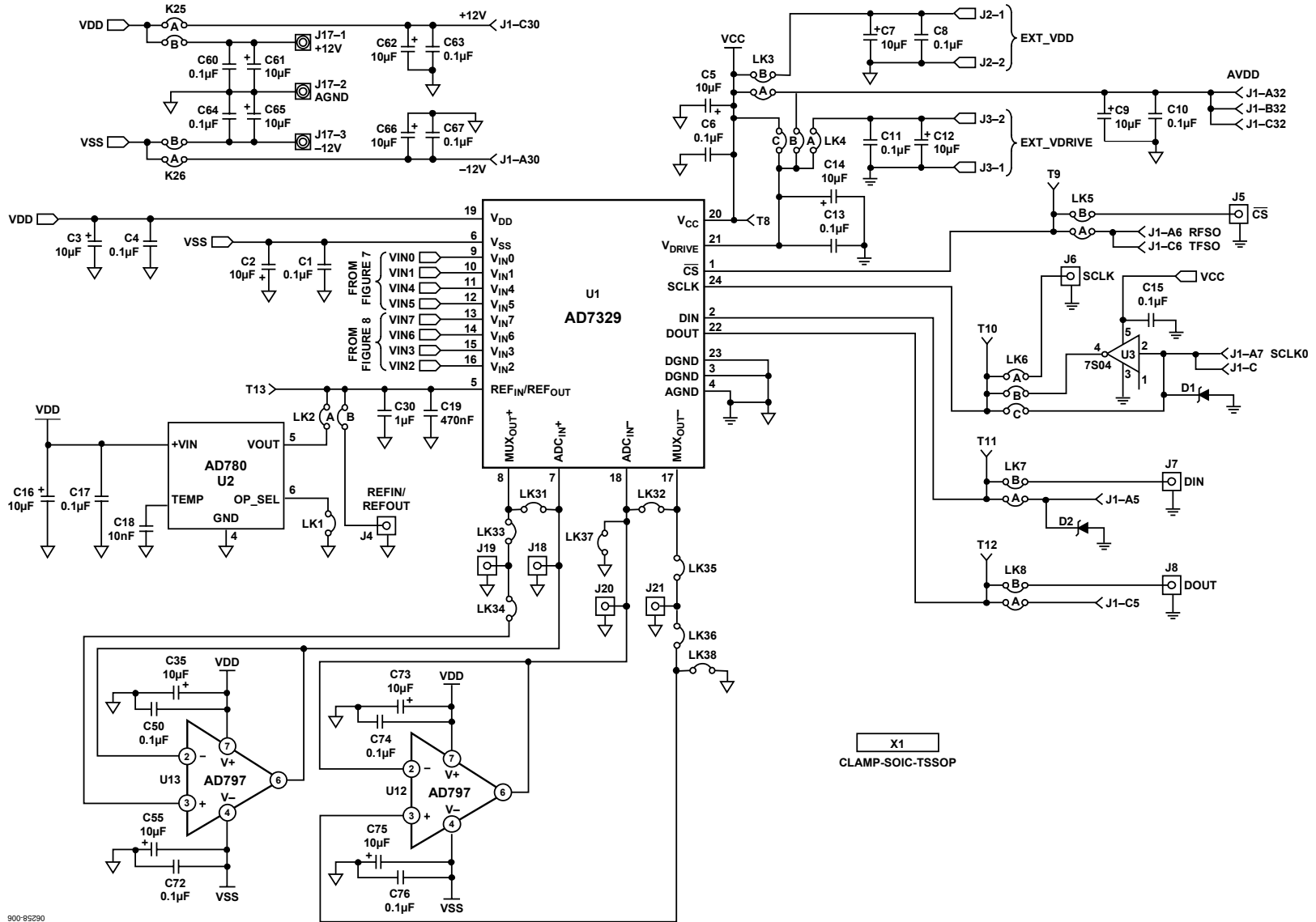

Figure 6. Schematic

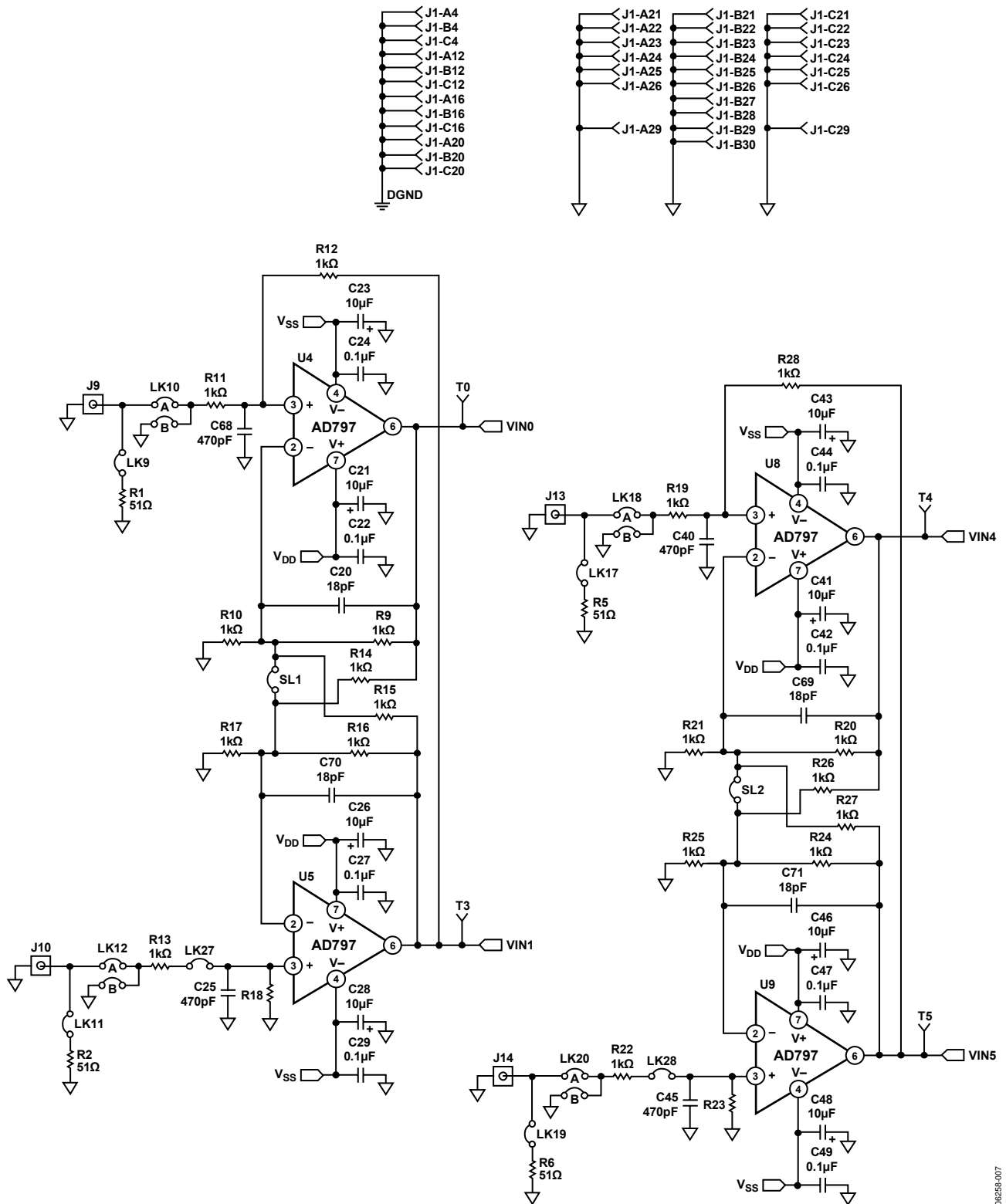

Figure 7. Schematic (Continued)

0625B-007

EVAL-AD7329CB

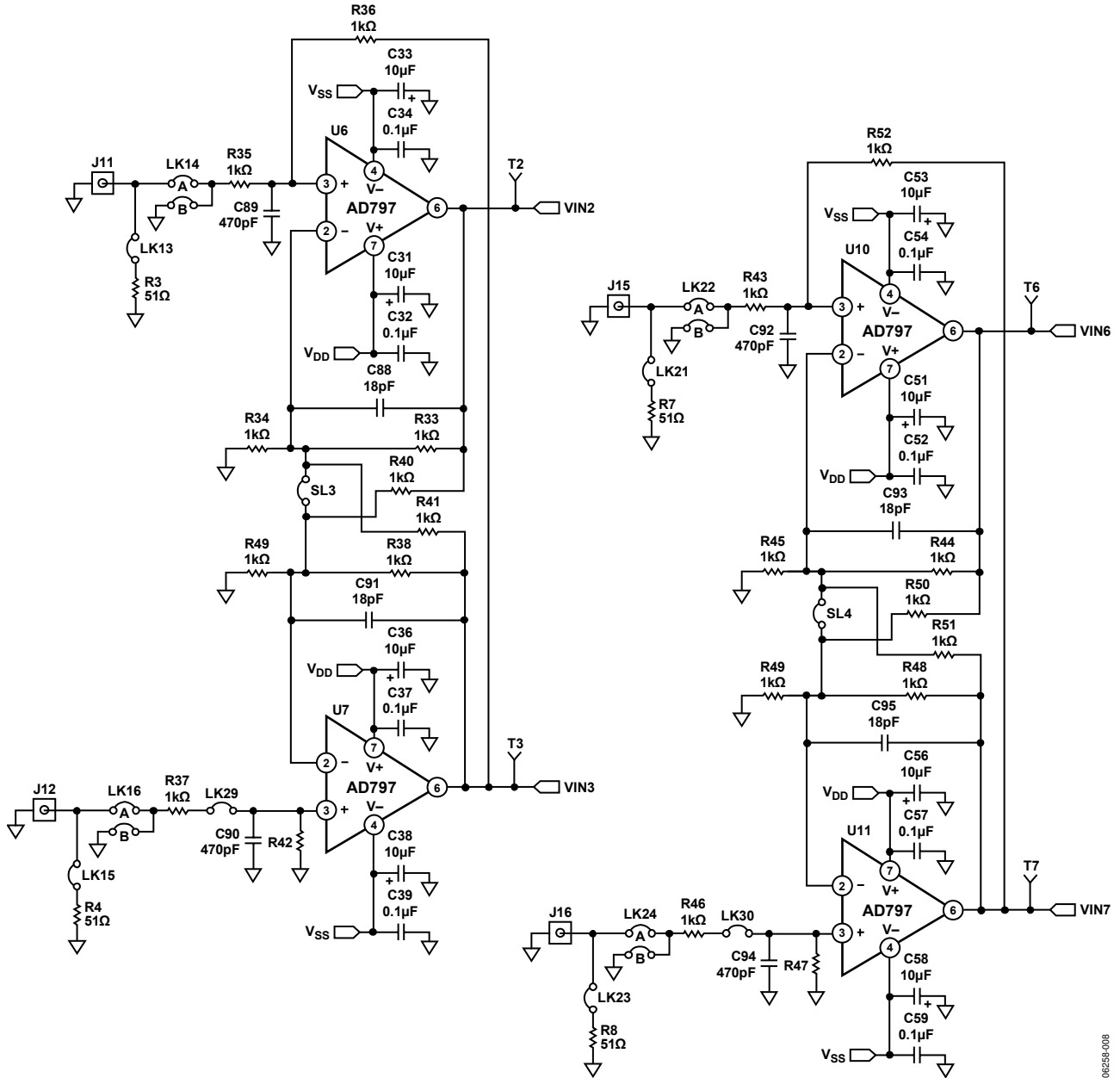

Figure 8. Schematic (Continued)

06258-008

ORDERING INFORMATION

ORDERING GUIDE

Model	Description
EVAL-AD7329CB	Evaluation Board

ESD CAUTION



ESD (electrostatic discharge) sensitive device. Charged devices and circuit boards can discharge without detection. Although this product features patented or proprietary protection circuitry, damage may occur on devices subjected to high energy ESD. Therefore, proper ESD precautions should be taken to avoid performance degradation or loss of functionality.

NOTES

NOTES

NOTES