



Chipsmall Limited consists of a professional team with an average of over 10 year of expertise in the distribution of electronic components. Based in Hongkong, we have already established firm and mutual-benefit business relationships with customers from,Europe,America and south Asia,supplying obsolete and hard-to-find components to meet their specific needs.

With the principle of “Quality Parts,Customers Priority,Honest Operation,and Considerate Service”,our business mainly focus on the distribution of electronic components. Line cards we deal with include Microchip,ALPS,ROHM,Xilinx,Pulse,ON,Everlight and Freescale. Main products comprise IC,Modules,Potentiometer,IC Socket,Relay,Connector.Our parts cover such applications as commercial,industrial, and automotives areas.

We are looking forward to setting up business relationship with you and hope to provide you with the best service and solution. Let us make a better world for our industry!



## Contact us

Tel: +86-755-8981 8866 Fax: +86-755-8427 6832

Email & Skype: info@chipsmall.com Web: www.chipsmall.com

Address: A1208, Overseas Decoration Building, #122 Zhenhua RD., Futian, Shenzhen, China



### FEATURES

- Full-featured evaluation board for the AD7484
- Compatibility with the EVAL-CONTROL BRD2 evaluation board controller
- Standalone capability
- On-board analog buffering and reference
- Various linking options
- PC software for control and data analysis when used with the EVAL-CONTROL BRD2

### GENERAL DESCRIPTION

This data sheet describes the setup and use of the AD7484 evaluation board. The AD7484 is a high speed, low power, 14-bit successive approximation ADC that operates from a single +5 V supply and features throughput rates of up to 3 MSPS. Full details on the AD7484 are available in the AD7484 data sheet, which is available from Analog Devices, Inc., and should be consulted in conjunction with this data sheet when using the evaluation board.

On-board components include the following:

- AD780 pin programmable +2.5 V or +3 V ultra high precision band gap reference
- AD829, AD8022, and AD711 op amps
- ADM809 reset generator
- Two 7S04 inverters
- 16-bit FCT245 type digital buffer.

Various link options are explained in detail in the Link Options section.

### FUNCTIONAL BLOCK DIAGRAM

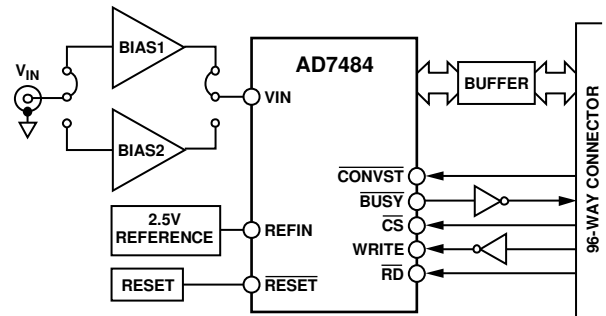

Figure 1.

Interfacing to this board is through a 96-way connector. This 96-way connector is compatible with the evaluation board controller [EVAL-CONTROL BRD2](#), which is also available from Analog Devices. External sockets are provided for  $\overline{\text{CONVST}}$ ,  $\overline{\text{RD}}$ ,  $\overline{\text{WR}}$ , and  $\overline{\text{CS}}$  signals, a bipolar analog input signal, a biased up unipolar signal, optional external reference, and offset voltages.

#### Rev. 0

Evaluation boards are only intended for device evaluation and not for production purposes. Evaluation boards are supplied "as is" and without warranties of any kind, express, implied, or statutory including, but not limited to, any implied warranty of merchantability or fitness for a particular purpose. No license is granted by implication or otherwise under any patents or other intellectual property by application or use of evaluation boards. Information furnished by Analog Devices is believed to be accurate and reliable. However, no responsibility is assumed by Analog Devices for its use, nor for any infringements of patents or other rights of third parties that may result from its use. Analog Devices reserves the right to change devices or specifications at any time without notice. Trademarks and registered trademarks are the property of their respective owners. Evaluation boards are not authorized to be used in life support devices or systems.

## TABLE OF CONTENTS

Features .....	1	Setting Up the EVAL-CONTROL BRD2 .....	7
General Description .....	1	Evaluation Board Software.....	8
Functional Block Diagram .....	1	Main Window .....	8
Revision History .....	2	Setup Menu Window .....	10
Evaluation Board Hardware.....	3	Changing and Loading the Configuration File .....	10
Power Supplies .....	3	Taking Samples .....	11
Link Options .....	3	Evaluation Board Schematics and Artwork.....	12
Initial Setup Conditions .....	5	Ordering Information.....	19
Evaluation Board Interfacing.....	6	Bill of Materials.....	19
Sockets .....	7	Ordering Guide .....	20
Connectors .....	7	ESD Caution.....	20
Operating with the EVAL-CONTROL BRD2 .....	7		

## REVISION HISTORY

10/07—Revision 0: Initial Version

## EVALUATION BOARD HARDWARE

### POWER SUPPLIES

When using this evaluation board with the EVAL-CONTROL BRD2, all supplies are provided from the EVAL-CONTROL BRD2 through the 96-way connector. When using the board as a standalone unit, external supplies must be provided.

This evaluation board has nine power supply inputs:

- $AV_{DD}$
- AGND
- +12 V
- -12 V
- AGND
- $DV_{DD}$
- DGND
- $V_{DRIVE}$
- DGND

If the evaluation board is used in standalone mode, a +5 V supply must be connected to both the  $AV_{DD}$  and  $DV_{DD}$  inputs. The +12 V and -12 V supplies are required for the op amps.

The  $V_{DRIVE}$  input can be connected to a supply from +2.7 V to +5 V, allowing the evaluation board to be connected to both +3 V and +5 V systems. The supplies are decoupled to the ground plane with 10  $\mu$ F tantalum and 0.1  $\mu$ F multilayer ceramic capacitors at the point where they enter the board. Noise on the supplies is further reduced with the use of EMC filters and ferrite beads. The supply pins of all the op amps and the reference are also decoupled with 10  $\mu$ F tantalum and 0.1  $\mu$ F ceramic capacitors, as are the  $V_{DD}$  pins of the AD7484.

This evaluation board consists of four layers. One of these layers is used as a dedicated ground plane, which allows for good decoupling and shielding.

### LINK OPTIONS

There are 25 link options that must be set according to operating setup requirements before the evaluation board can be used. These link options and their functions are listed in Table 1. There is no Link 25.

**Table 1. Link Options and Functions**

Link No.	Function
LK1	Selects the source of $\overline{CONVST}$ input. In Position A, sources $\overline{CONVST}$ from the external connector, J9. In Position B, connects $\overline{CONVST}$ to the 96-way connector.
LK2	Selects the source for the bias up voltage. In Position A, connects the bias up voltage to the reference voltage (divided down by R6 and R8). In Position B, connects the bias up voltage to $AV_{DD}$ . In Position C, connects the bias up voltage to the external connector, J10.
LK3	Shorts out the 1 k $\Omega$ series input resistor on the analog input.
LK4	In conjunction with LK5, selects the op amp to use in the analog input bias up circuitry. Both links must be set to the same position. In Position A, selects the AD829. In Position B, selects the AD8022.
LK5	See LK4.
LK6	Puts the AD7484 in standby mode. In Position A, connects the STBY (standby) pin to $DV_{DD}$ , putting the part in standby mode. In Position B, connects the STBY (standby) pin to GND for normal operation.
LK7	Puts the AD7484 in nap mode. In Position A, connects the NAP pin to $DV_{DD}$ , putting the part in nap mode. In Position B, connects the NAP pin to GND for normal operation.
LK8	Selects whether the clip input is tied high or low. See the AD7484 data sheet for additional details. In Position A, ties the CLIP pin to $DV_{DD}$ . In Position B, ties the CLIP pin to GND.
LK9	Selects whether the MODE1 input is tied high or low. See the AD7484 data sheet for additional details. In Position A, ties the MODE1 pin to $DV_{DD}$ . In Position B, ties the MODE1 pin to GND.
LK10	Selects whether the MODE2 input is tied high or low. See the AD7484 data sheet for additional details. In Position A, ties the MODE2 pin to $DV_{DD}$ . In Position B, ties the MODE2 pin to GND.
LK11	Configures the AD7484 for use with an internal or external reference. With this link in position, the part is configured for use with an external +2.5 V reference.

# EVAL-AD7484

Link No.	Function
LK12	Selects the source for the $V_{DRIVE}$ voltage. In Position A, connects $V_{DRIVE}$ to $DV_{DD}$ . In Position B, takes $V_{DRIVE}$ from the external connector J5.
LK13	Selects the source for the external reference. In Position A, selects the on-board AD780. In Position B, selects the external connector J4.
LK14	When using an external reference, LK14 and LK15 should be in place to connect the reference pins to the external reference source.
LK15	See LK14.
LK16	Selects the source for the $DV_{DD}$ supply. In Position A, selects the 96-way connector (EVAL-CONTROL BRD2) as the source. In Position B, selects the external connector J7 as the source.
LK17	Selects whether the analog input is taken from the on-board op amps or directly from the external connector J3. In Position A, selects the op amps. In Position B, selects J3.
LK18	Inserting LK18 terminates the analog input applied to J2 with a 50 $\Omega$ resistor.
LK19	Selects the source for the $AV_{DD}$ supply. In Position A, selects the 96-way connector (EVAL-CONTROL BRD2) as the source. In Position B, selects the external connector J6 as the source.
LK20	Selects the source for the +12 V supply. In Position A, selects the 96-way connector (EVAL-CONTROL BRD2) as the source. In Position B, selects the external connector J8 as the source.
LK21	Selects the source for the -12 V supply. In Position A, selects the 96-way connector (EVAL-CONTROL BRD2) as the source. In Position B, selects the external connector J8 as the source.
LK22	Selects the source of $\overline{CS}$ input. In Position A, sources $\overline{CS}$ from the external connector J11. In Position B, connects $\overline{CS}$ to the 96-way connector.
LK23	Selects the source of $\overline{RD}$ input. In Position A, sources $\overline{RD}$ from the external connector J12. In Position B, connects $\overline{RD}$ to the 96-way connector.
LK24	Selects the source of $\overline{WR}$ input. In Position A, sources $\overline{WR}$ from the external connector J13. In Position B, connects $\overline{WR}$ to the 96-way connector.
LK25	N/A
LK26	Inserting LK26 terminates the analog input applied to J3 with a 50 $\Omega$ resistor.



## INITIAL SETUP CONDITIONS

Care should be taken before applying power or signals to the evaluation board to ensure that all link positions support the required operating mode. Failure to do this could result in damage to the evaluation board.

The positions in which all the links are set when the evaluation board is shipped are given in Table 2. The board is also set up for use with the EVAL-CONTROL BRD2 when shipped.

**Table 2. Initial Link Positions**

Link No.	Position	Function
LK1	B	CONVST input is connected to the 96-way connector.
LK2	A	The bias up voltage is connected to the reference voltage (divided down by R6 and R8).
LK3	IN	The 1 k $\Omega$ series input resistor on the analog input is shorted.
LK4	A	AD829 is used in the analog input bias up circuitry.
LK5	A	AD829 is used in the analog input bias up circuitry.
LK6	B	The STBY (standby) pin is connected to GND for normal operation.
LK7	B	The NAP pin is connected to GND for normal operation.
LK8	A	The CLIP pin is tied to DV <sub>DD</sub> . See the AD7484 data sheet for additional details.
LK9	B	The MODE1 input is tied to GND. See the AD7484 data sheet for additional details.
LK10	A	The MODE2 input is tied to DV <sub>DD</sub> . See the AD7484 data sheet for additional details.
LK11	IN	The AD7484 is configured for use with an external +2.5 V reference.
LK12	A	V <sub>DRIVE</sub> is connected to DV <sub>DD</sub> .
LK13	A	The AD780 is selected as the source for external reference.
LK14	IN	The reference pins are connected to the external reference source.
LK15	IN	The reference pins are connected to the external reference source.
LK16	A	The DV <sub>DD</sub> supply is sourced from the 96-way connector (EVAL-CONTROL BRD2).
LK17	A	Analog input is taken from the on-board op amps.
LK18	OUT	No 50 $\Omega$ termination on the analog input is applied to J2.
LK19	A	The V <sub>DD</sub> supply is sourced from the 96-way connector (EVAL-CONTROL BRD2).
LK20	A	The +12 V supply is sourced from the 96-way connector (EVAL-CONTROL BRD2).
LK21	A	The -12 V supply is sourced from the 96-way connector (EVAL-CONTROL BRD2).
LK22	B	$\overline{CS}$ is connected to the 96-way connector.
LK23	B	$\overline{RD}$ is connected to the 96-way connector.
LK24	B	$\overline{WR}$ is connected to the 96-way connector.
LK25	N/A	
LK26	OUT	No 50 $\Omega$ termination on the analog input is applied to J3.

## EVALUATION BOARD INTERFACING

Interfacing to the evaluation board is via a 96-way connector J1. J1 is used to connect the evaluation board to the EVAL-CONTROL BRD2 or other system. The pinout for the J1 connector is shown in Figure 2, and its pin designators are given in Table 3.

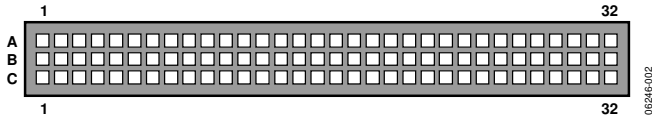

Figure 2. Pin Configuration for the 96-Way Connector J1

Table 3. J1 Connector Pin Designators

Pin	Description
FL0	Flag Zero. This output is connected to the $\overline{\text{CONVST}}$ pin of the AD7484 via LK1.
$\overline{\text{IRQ2}}$	Interrupt Request 2. This input is connected to the $\overline{\text{BUSY}}$ output of the AD7484 through the inverter U7.
$\overline{\text{RD}}$	Read. An output is connected to the $\overline{\text{RD}}$ pin of the AD7484 via LK23.
$\overline{\text{WR}}$	Write. An output is connected to the Write input of the AD7484 via LK24 through the inverter U4.
$\overline{\text{CS}}$	Chip Select. An output is connected to the $\overline{\text{CS}}$ input pin of the AD7484 via LK22.
D0 to D14	Data lines. These bidirectional data lines are connected to the data bus of the AD7484 through the buffer U2.
DGND	Digital Ground. These lines are connected to the ground plane of the AD7484 evaluation board.
AGND	Analog Ground. These lines are connected to the ground plane of the AD7484 evaluation board.
DV <sub>DD</sub>	Digital +5 V supply. These lines are connected to the DV <sub>DD</sub> supply line on the board via LK16.
AV <sub>DD</sub>	Analog +5 V supply. These lines are connected to the AV <sub>DD</sub> supply line on the board via LK19.
+12 V	+12 V supply. These lines are connected to the +12 V supply line on the board via LK20.
-12 V	-12 V supply. These lines are connected to the -12 V supply line on the board via LK21.

Table 4. 96-Way Connector Pin Functions<sup>1</sup>

Pin	ROW A	ROW B	ROW C
1			
2		D0	
3		D1	
4	DGND	DGND	DGND
5		D2	
6		D3	
7		D4	
8	DV <sub>DD</sub> Edge	DV <sub>DD</sub> Edge	DV <sub>DD</sub> Edge
9	$\overline{\text{RD}}$	D5	$\overline{\text{WR}}$
10		D6	$\overline{\text{CS}}$
11		D7	
12	DGND	DGND	DGND
13		D8	
14		D9	
15		D10	
16	DGND	DGND	DGND
17	FL0	D11	$\overline{\text{IRQ2}}$
18	D12	D13	D14
19			
20	DGND	DGND	DGND
21	AGND	AGND	AGND
22	AGND	AGND	AGND
23	AGND	AGND	AGND
24	AGND	AGND	AGND
25	AGND	AGND	AGND
26	AGND	AGND	AGND
27		AGND	
28		AGND	
29	AGND	AGND	AGND
30	-12 V	AGND	+12 V
31			
32	AV <sub>DD</sub>	AV <sub>DD</sub>	AV <sub>DD</sub>

<sup>1</sup> The unused pins of the 96-way connector are not shown.

## SOCKETS

There are eight input sockets relevant to the operation of the AD7484 on this evaluation board. The functions of these sockets are outlined in Table 5.

**Table 5. Socket Functions**

Socket	Function
J2	Sub-miniature BNC socket for bipolar input signals that are biased up by the on-board op amps into VIN.
J3	Sub-miniature BNC socket for unipolar input signals that are connected directly to VIN.
J4	Sub-miniature BNC socket for an external reference.
J9	Sub-miniature BNC socket for an external $\overline{\text{CONVST}}$ signal.
J10	Sub-miniature BNC socket for an external offset voltage that is used to bias up the signal applied at J2.
J11	Sub-miniature BNC socket for an external $\overline{\text{CS}}$ signal.
J12	Sub-miniature BNC socket for an external $\overline{\text{RD}}$ signal.
J13	Sub-miniature BNC socket for an external $\overline{\text{WR}}$ signal.

## CONNECTORS

There are five connectors on the AD7484 evaluation board, outlined in Table 6.

**Table 6. Connector Functions**

Socket	Function
J1	96-way connector for parallel interface and power supply connections.
J5	External $V_{\text{DRIVE}}$ connector.
J6	External $AV_{\text{DD}}$ and AGND connector.
J7	External $DV_{\text{DD}}$ and DGND connector.
J8	External +12 V, -12 V, and AGND power connector.

## OPERATING WITH THE EVAL-CONTROL BRD2

The evaluation board can operate in standalone mode or in conjunction with the EVAL-CONTROL BRD2, which is available from Analog Devices. When operated with the EVAL-CONTROL BRD2, all supplies and control signals required to operate the AD7484 are provided by the EVAL-CONTROL BRD2. Software to communicate with the control board and the AD7484 is provided with the AD7484 evaluation board package. The EVAL-CONTROL BRD2 also operates with all Analog Devices evaluation boards whose part numbers end with the letters CB.

The 96-way connector on the EVAL-AD7484 plugs directly into the 96-way connector on the EVAL-CONTROL BRD2. The EVAL-CONTROL BRD2 provides all supplies for the evaluation board. It is powered from a 12 V ac transformer. Suitable transformers are available from Analog Devices as accessories under the following part numbers:

EVAL-110VAC-US: For use in the U.S. or Japan

EVAL-220VAC-UK: For use in the UK

EVAL-220VAC-EU: For use in Europe

These transformers are also available from other suppliers, including Digi-key (US) and Campbell Collins (UK).

Connection between the EVAL-CONTROL BRD2 and the parallel port of a PC is via a standard Centronics printer port cable that is provided as part of the EVAL-CONTROL BRD2 package. See the manual that accompanies the EVAL-CONTROL BRD2 for more details on the EVAL-CONTROL BRD2 package.

## SETTING UP THE EVAL-CONTROL BRD2

The evaluation board software should be installed on the PC, and the evaluation board and the EVAL-CONTROL BRD2 should be connected, before the EVAL-CONTROL BRD2 is connected to the PC, as follows:

1. Install the EVAL-AD7484 evaluation board software.
2. Connect the evaluation board and the EVAL-CONTROL BRD2 via the 96-way connector.
3. Apply power to the EVAL-CONTROL BRD2. At this stage, the red LED should also be flashing to indicate that the EVAL-CONTROL BRD2 is functional and ready to receive instructions.
4. Load the installed software before connecting the printer port cable to ensure that the printer port is initialized correctly.
5. Connect the printer port cable between the PC and the EVAL-CONTROL BRD2.



## EVALUATION BOARD SOFTWARE

The software that controls the EVAL-CONTROL BRD2, and therefore the evaluation board, has two windows. The window shown in Figure 3 is the window that appears when the software is first run. It displays information about samples from the evaluation board in either Fast Fourier Transform (FFT) mode (Figure 3) or histogram mode (Figure 4). The main window also provides access to the Setup Menu window (shown in Figure 5), where the configuration file for the evaluation board is loaded.

### MAIN WINDOW

The main window (see Figure 3 and Figure 4) allows the user to read a predetermined number of samples from the evaluation

board and display them in both the time and the frequency domains. The window is divided into three sections.

The upper third contains the control buttons, the menu bar, and various status display boxes. The control buttons allow the user to take samples, reset the part, and quit the program. The menu bar allows the user to display the setup menu, select the printer port to control the EVAL-CONTROL BRD2, load and save data, and get information about the software. The status display boxes indicate the setup of the evaluation board, number of samples taken, and other information or error messages that are generated.

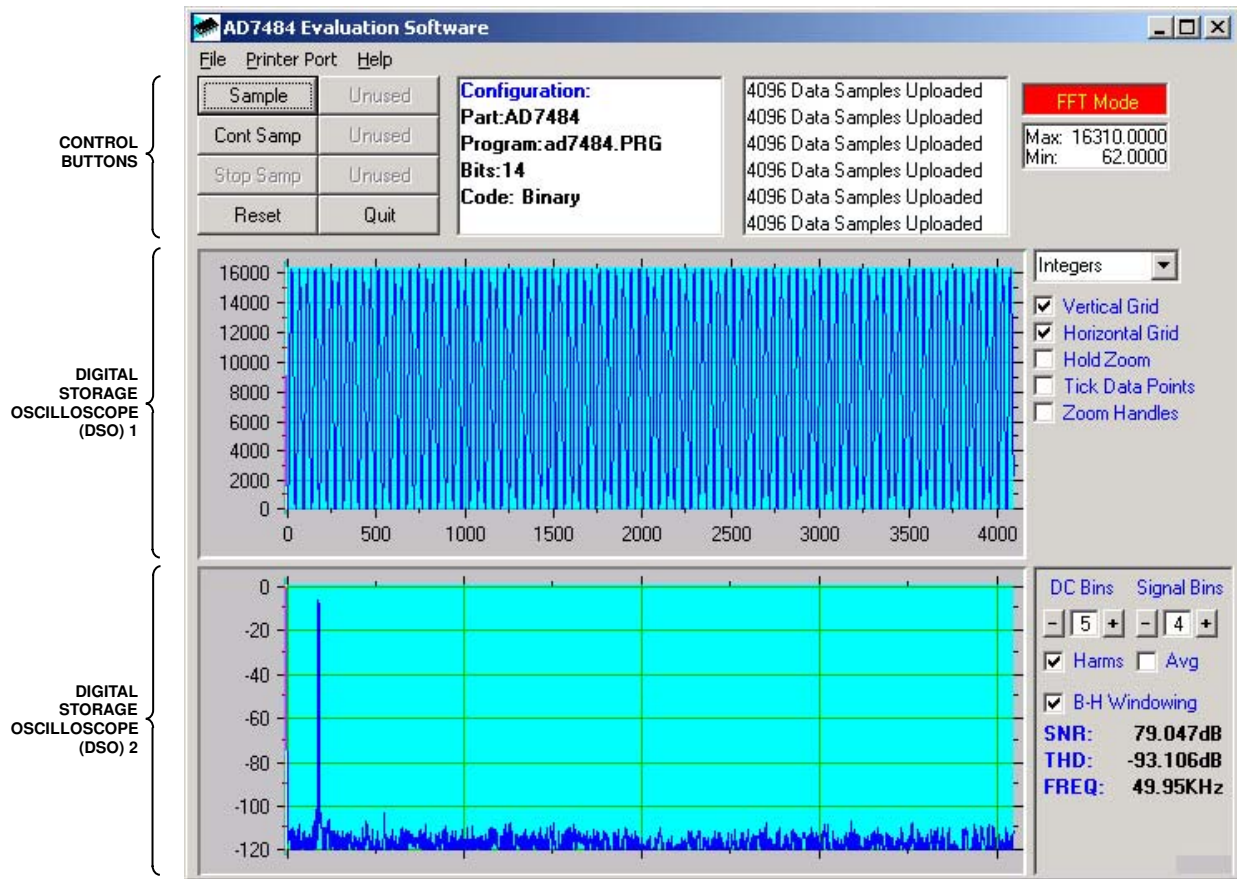

Figure 3. AD7484 Main Window

The middle third of the main window contains a digital storage oscilloscope (DSO) that displays samples uploaded from the EVAL-CONTROL BRD2. The samples can be displayed either as integer values or as voltages (determined by the input range of the device in question). When samples are displayed, clicking any point in the graph displays the sample number and the value of the point directly beneath the cursor. Along the axis of the graph are zoom handles that allow the user to zoom in and out to get a closer look at a sample. When another set of samples is taken, the graph attempts to display all values collected unless the **Hold Zoom** check box is selected. In this case, the graph keeps the same axis settings as for the previous set of data samples. Additional check boxes are provided to give

the user control over the vertical and horizontal grids and data points.

The lower third of the window contains either a Fast Fourier Transform (FFT) of the data or a histogram that displays the number of occurrences of each code read back. The FFT (default option) is typically used to show an ADC's performance in the frequency domain, while the histogram gives an indication of the ADC's performance with DC signals. The option displayed can be toggled by clicking the **FFT Mode/Histogram Mode** button at the top right of the window. Figure 4 shows how the main window looks when histogram mode is selected.

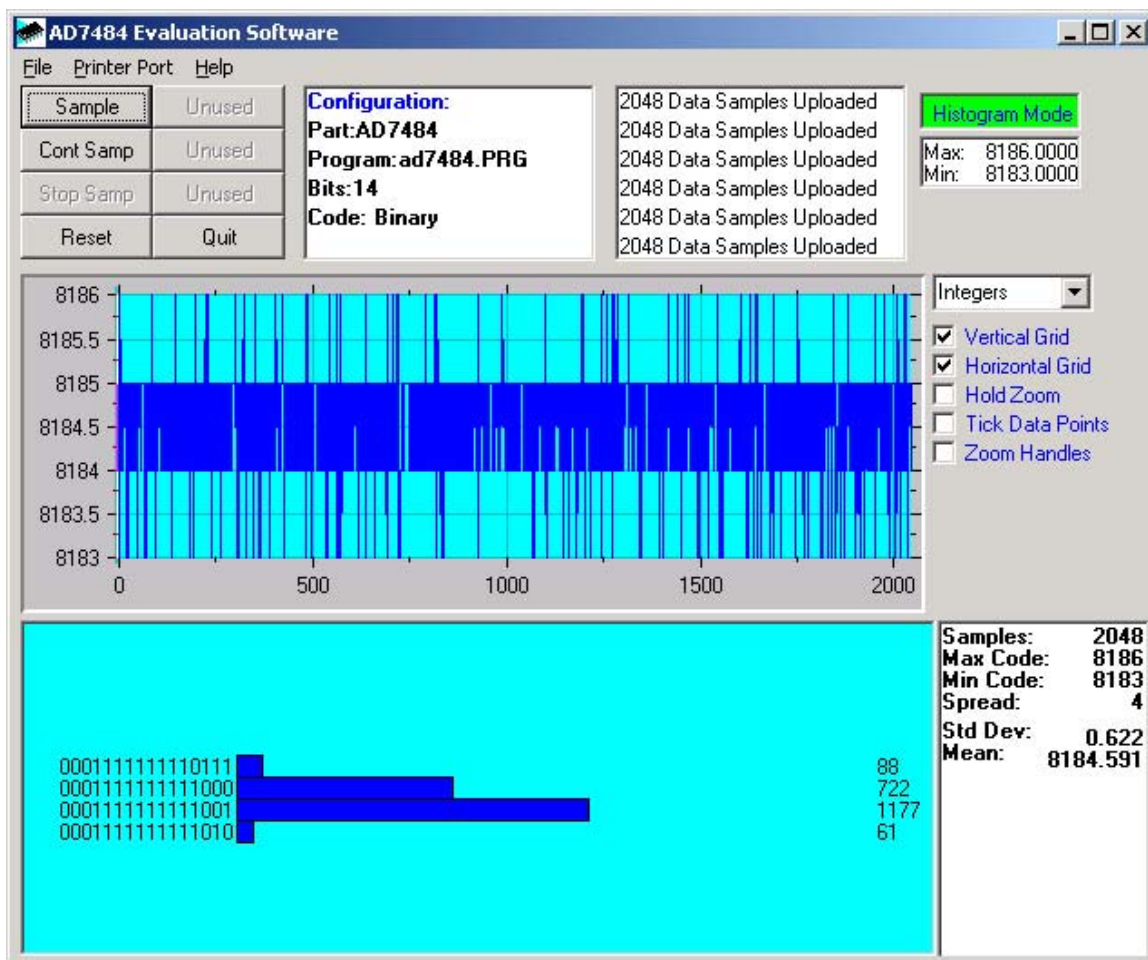

Figure 4. AD7484 Main Window – Histogram Mode

## SETUP MENU WINDOW

The **Setup Menu** window, shown in Figure 5, is used to load the required configuration file for the evaluation board. When the configuration file is loaded, the software acquires detailed information about the evaluation board and part connected to the EVAL-CONTROL BRD2, such as the number of bits, maximum sampling rate, output coding, maximum analog input, and power supply requirements. The configuration file also tells the software the name of the DSP program file that it should download to the EVAL-CONTROL BRD2. These files are supplied by Analog Devices with the evaluation board.

## CHANGING AND LOADING THE CONFIGURATION FILE

When the hardware is set up, the software can be used to control the EVAL-CONTROL BRD2 and the evaluation board. To display and load current setup information, do the following:

1. Select the **File** menu in the main window and click **Setup Menu**.
2. View all available configuration files in the **Select a Configuration File** box at the top left of the **Setup Menu** window. These are text based files that contain information about the evaluation boards.
3. Select the relevant configuration file and click **Load**. In the case of the AD7484 evaluation board, only one configuration file is available.

The EVAL-CONTROL BRD2 is then reset, and the DSP program is downloaded. When the download is complete, the power supply settings in the configuration file are set and some

of the relays may be heard clicking. Dropdown menu items such as **Select No. of Samples** and **Select Sample Frequency** are set to the default values specified in the configuration file. These values can be changed. When all the settings are selected, click **Close** to return to the main window.

### Software Configuration Files

Software configuration files give the EVAL-CONTROL BRD2 information about how the software and hardware should perform. They contain information such as the name of the DSP program to be downloaded, the default and maximum sampling frequencies, the number of samples to take, and the power supply settings to use. The following is a typical software configuration file (\*.cfg):

```
[EVAL-CONTROL BOARD]
partname:AD7484
programname:ad7484.PRG
samplefrequency:1200000
maxsamplefrequency:2200000
samples:2048

+/-15V:on
dvdd:5:on
avdd:5:on
bus:on
;options 2scomp, binary
dataformat:binary
numberofbits:14
inputVmax:2.5
inputVmin:0
[endofconfig]
```

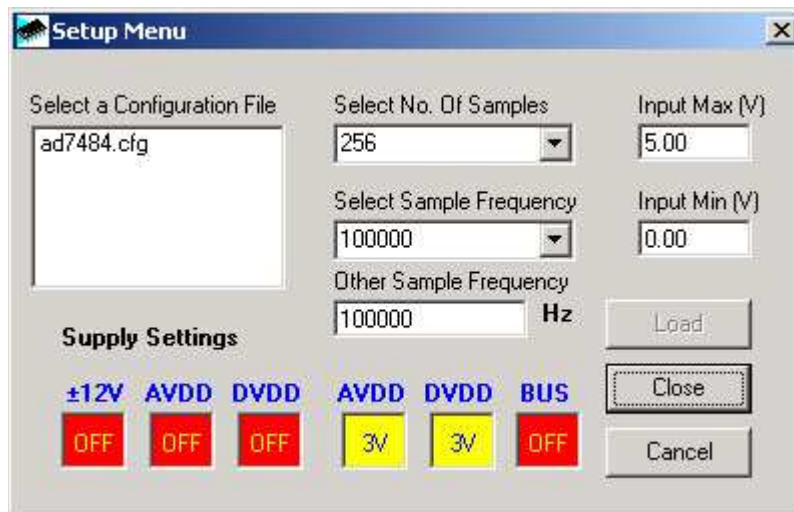

Figure 5. Setup Menu Window

## TAKING SAMPLES

The main window (see Figure 3 and Figure 4) is used to display and read samples and additionally to control the EVAL-CONTROL BRD2 and the AD7484 evaluation board. The evaluation board can run at up to 2.2 MSPS, so the user can choose any sampling frequency up to this rate. The number of samples to be taken can also be chosen. These samples are uploaded and displayed, and an FFT and a histogram are calculated and displayed.

Sampling is controlled through the main window menus and controls and displayed in list boxes and oscilloscopes (DSOs).

### Menu Bar

#### File Menu

**Setup Menu.** Displays the Setup Menu window, as shown in Figure 5.

**Load Raw Data.** Loads data that has been saved by the software during a previous session.

**Save Raw Data.** Saves the current set of sample data points. The data can be reloaded to the evaluation software later or can be used by other programs for analysis.

**Save Binary Data.** Saves the current set of sample data points in binary format as a text file. This option can be useful for tasks such as examining code flicker and looking for stuck bits.

**Save FFT Data.** Saves the current set of FFT data points. FFT data cannot be reloaded into the EVAL-CONTROL BRD2 software but can be loaded into other software packages for additional analysis.

**Exit.** Quits the program.

#### Printer Port Menu

Selects the printer port used for communication with the EVAL-CONTROL BRD2, as follows:

**LPT1.** Selects 0x378 as the printer port base address. This is the default option.

**LPT2.** Selects 0x278 as the printer port base address.

**PRN.** Selects 0x3BC as the printer port base address.

#### Help Menu

Provides information about the current version of the software.

#### Controls

**Sample.** Instructs the EVAL-CONTROL BRD2 to take the required number of samples at the required frequency from the evaluation board.

**Cont Samp.** Repeats the sampling process indefinitely until **Stop Samp** is clicked. While the software is continuously sampling data, the other control buttons are disabled.

**Stop Samp.** Stops the sampling process.

**Reset.** Causes the EVAL-CONTROL BRD2 to perform a reset. When this happens, the power supplies to the evaluation board are turned off and the program in the DSP memory is lost. The user should repeat the setup instructions to download another program if required.

**Quit.** Exits the software, but the program running on the EVAL-CONTROL BRD2 is not terminated.

EVALUATION BOARD SCHEMATICS AND ARTWORK

900-99290

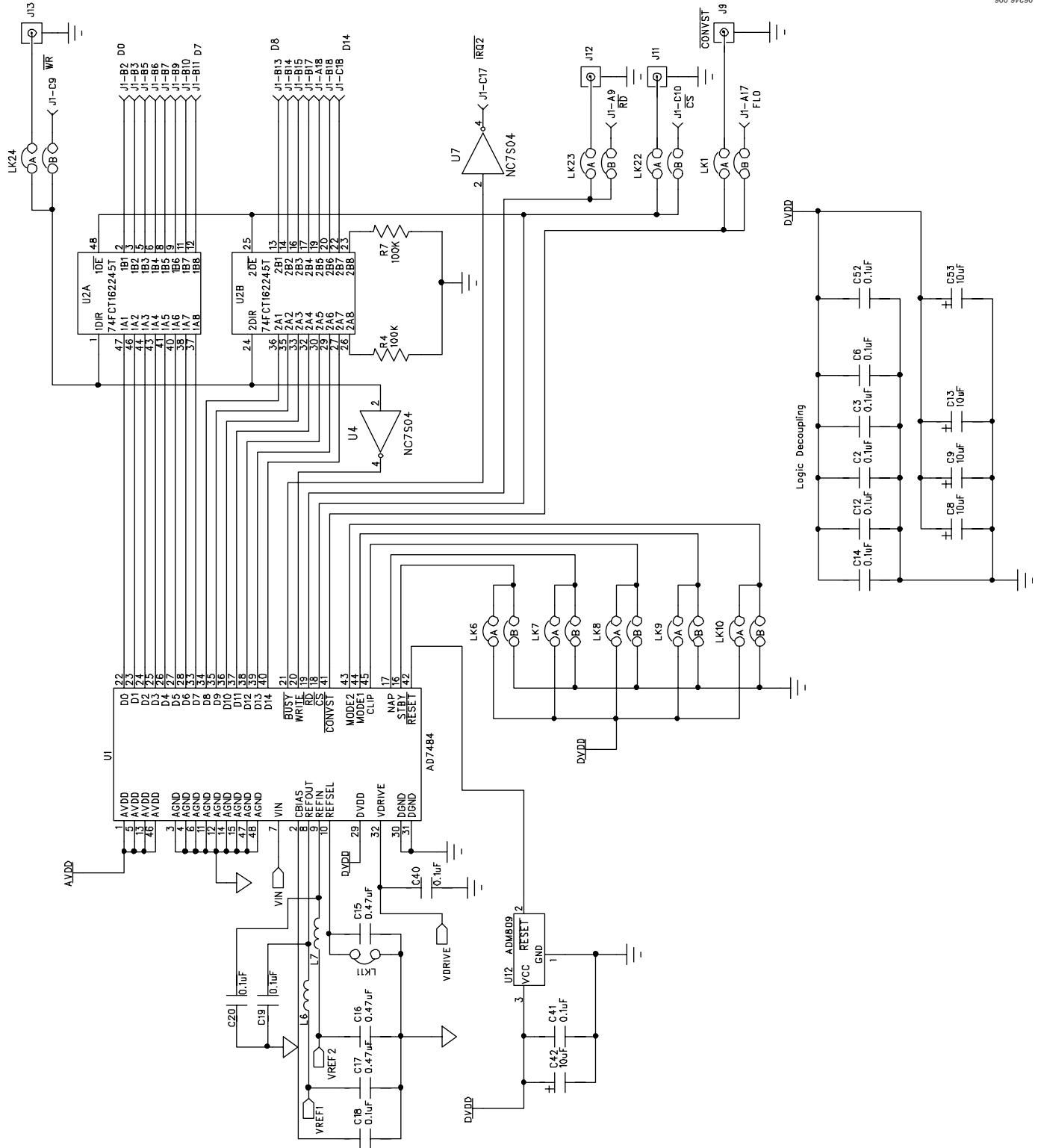

Figure 6. AD7484 Evaluation Board Schematic 1

06246-007

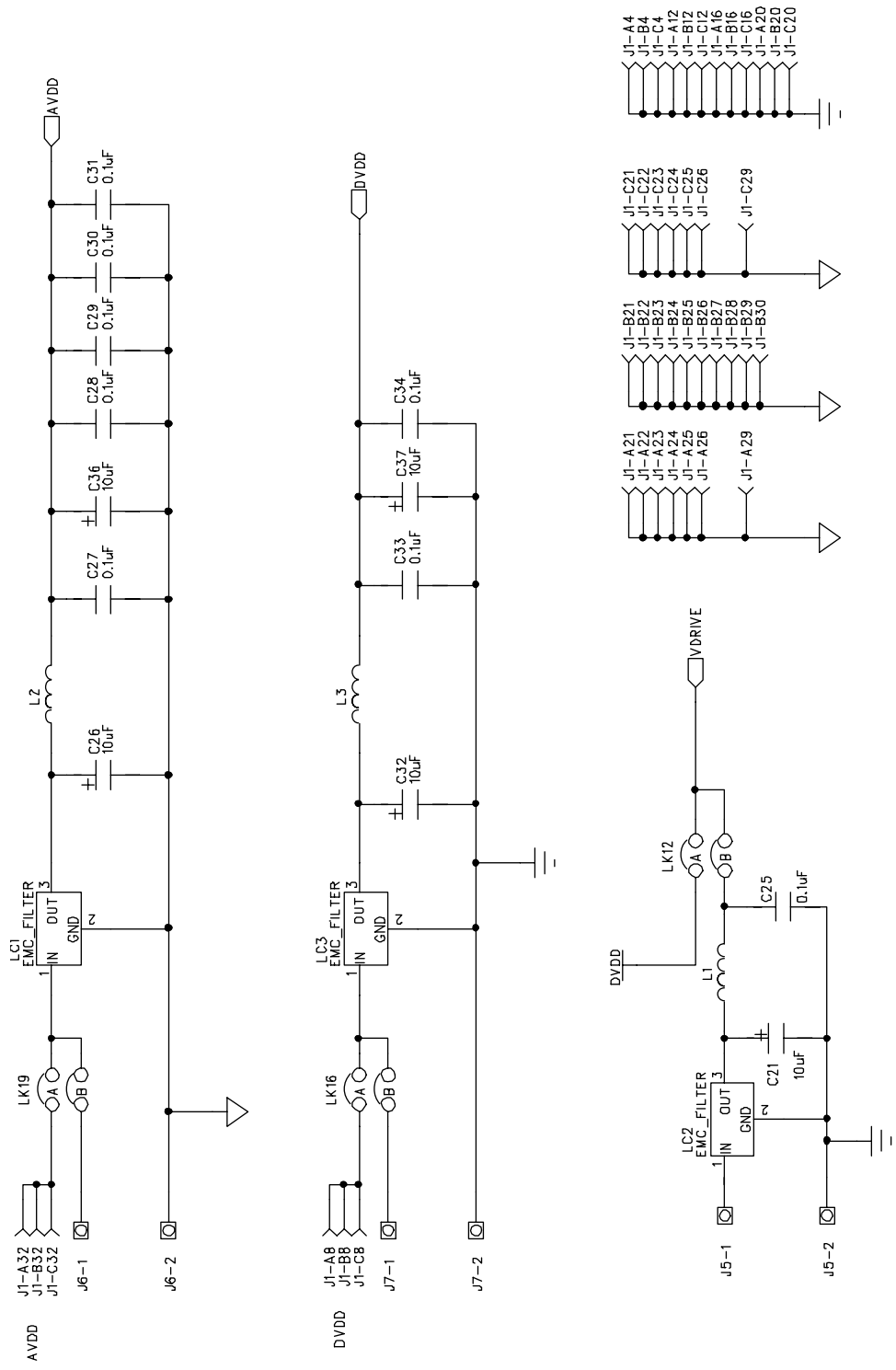

Figure 7. AD7484 Evaluation Board Schematic 2A

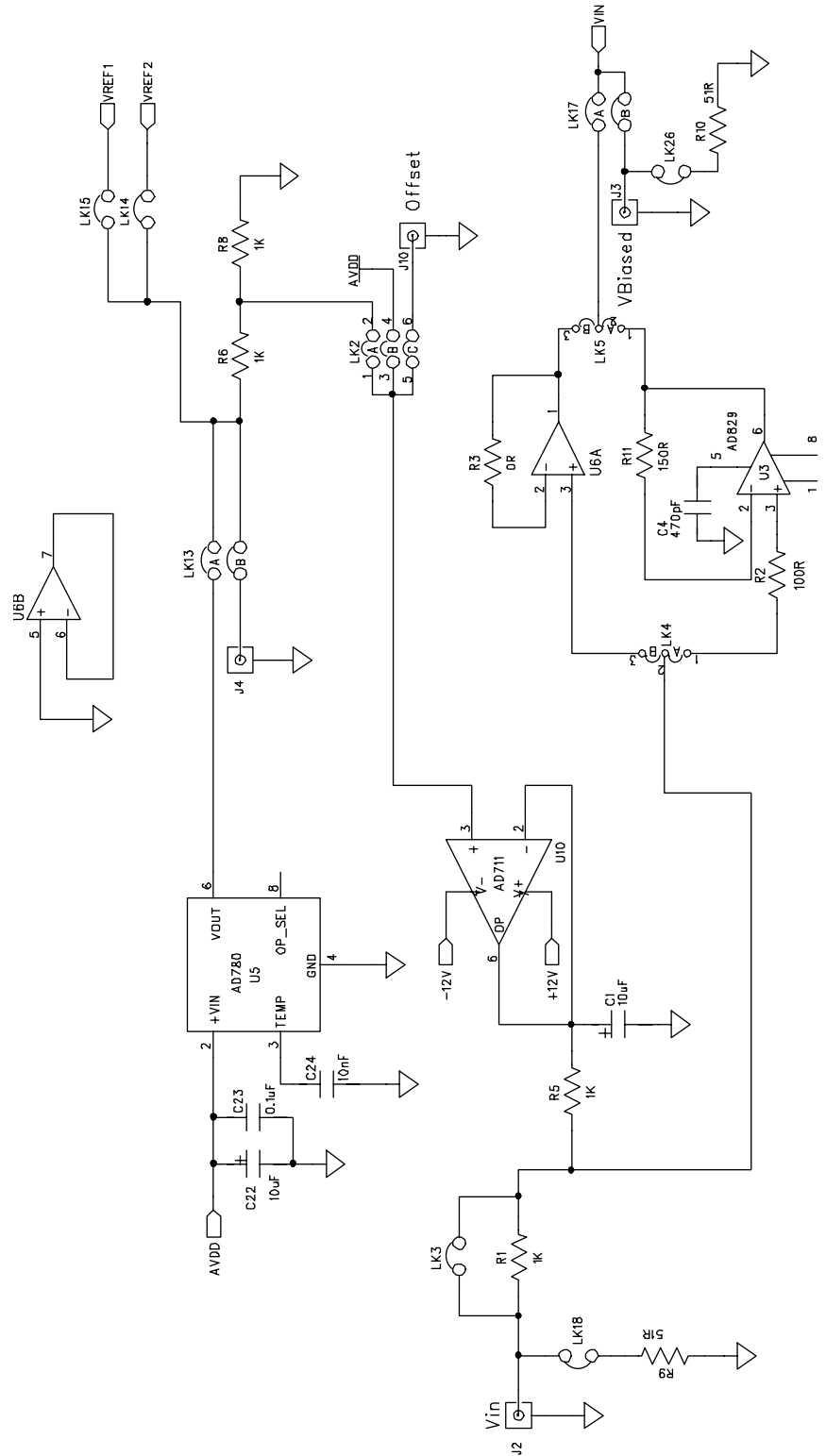

Figure 8. AD7484 Evaluation Board Schematic 2B



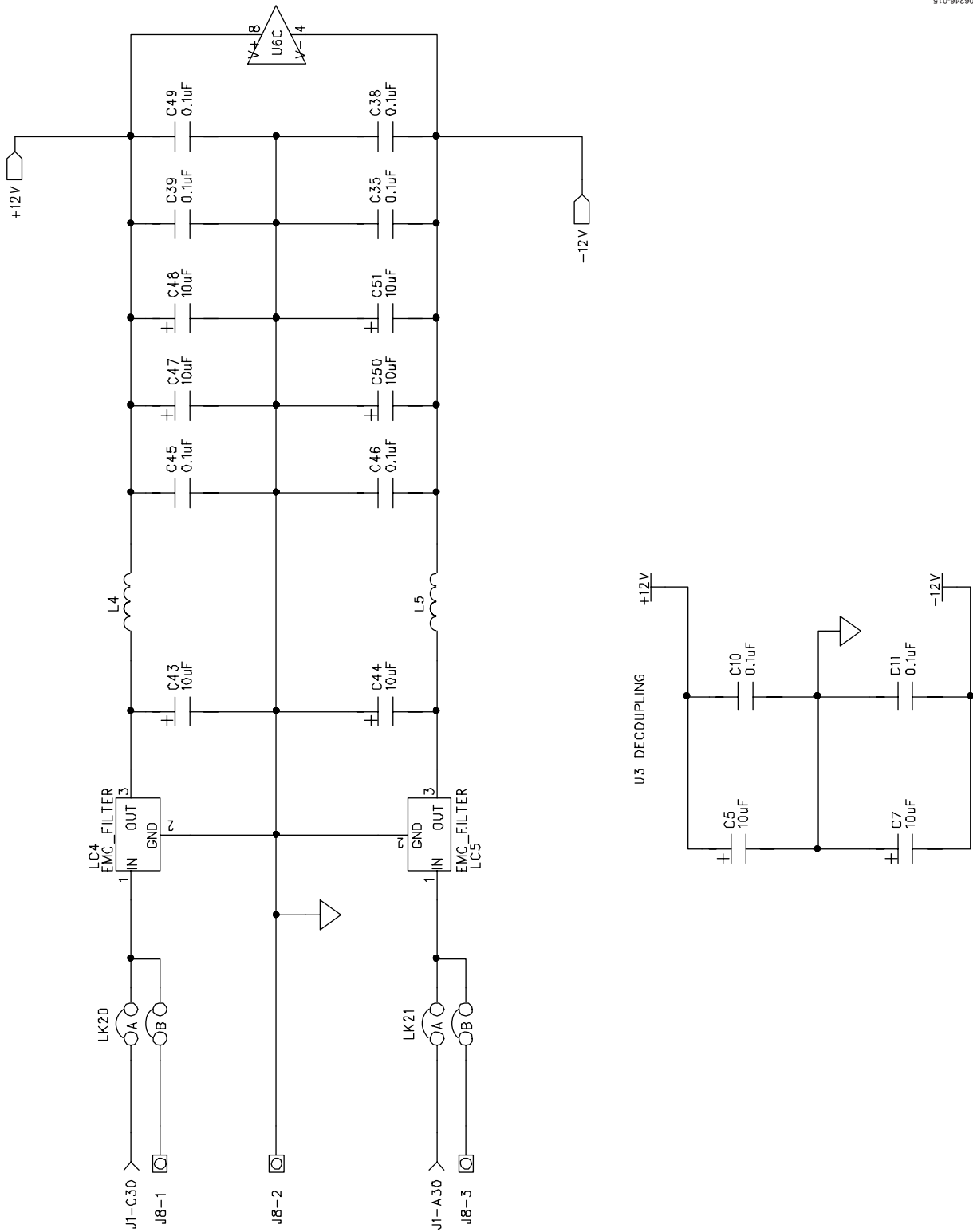

Figure 9. AD7484 Evaluation Board Schematic 2C

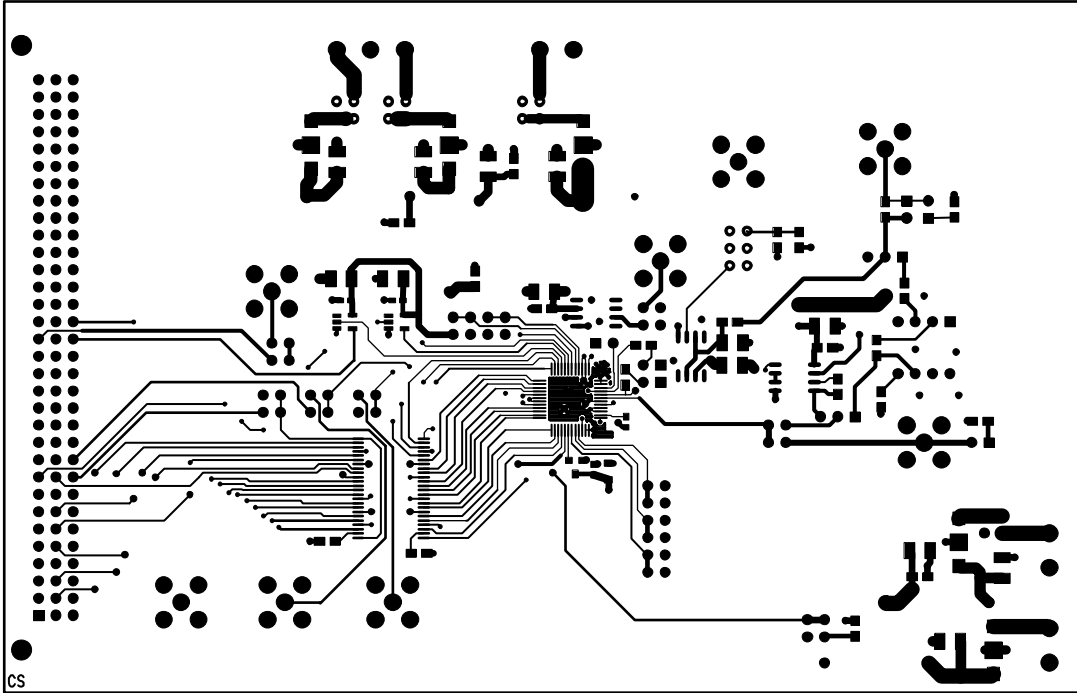

Figure 10. Top Layer Etch

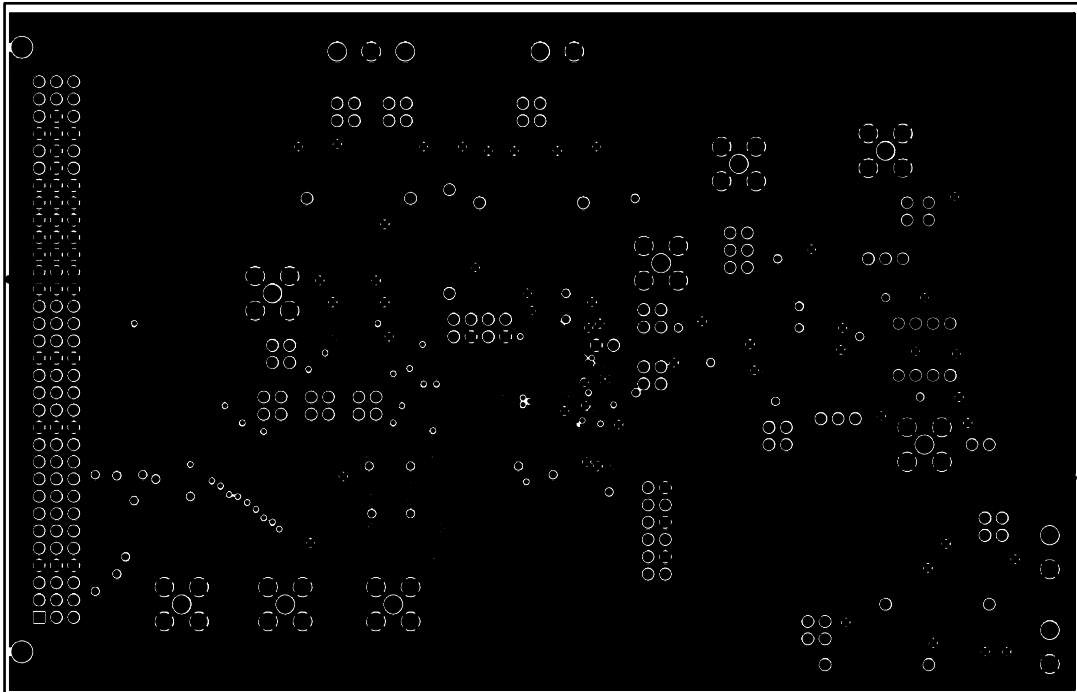
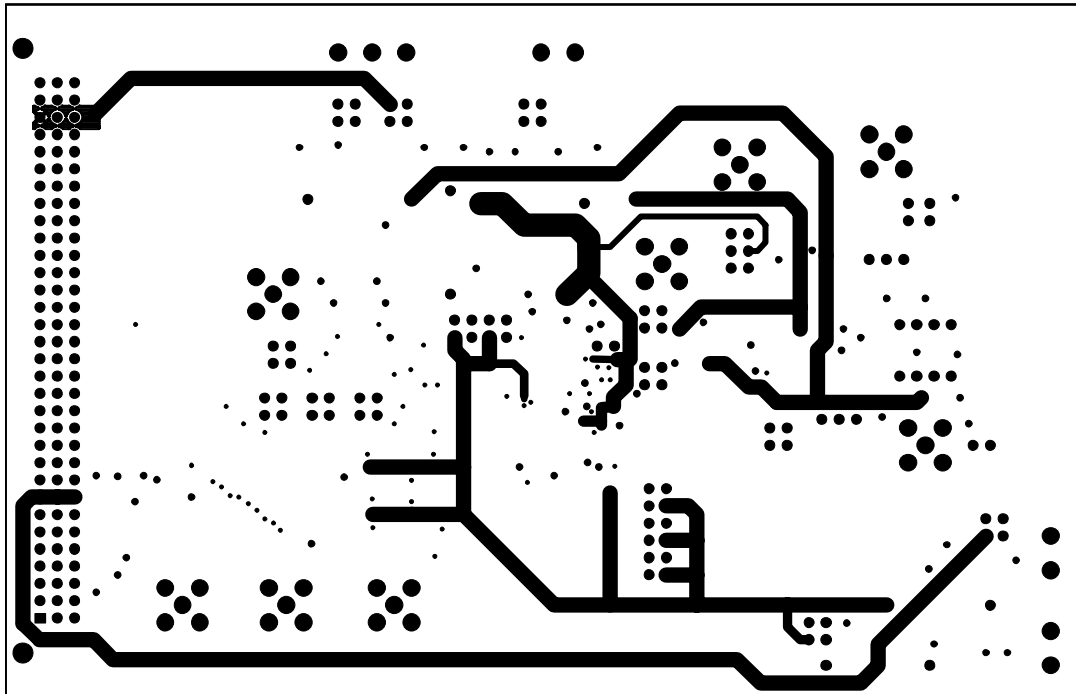
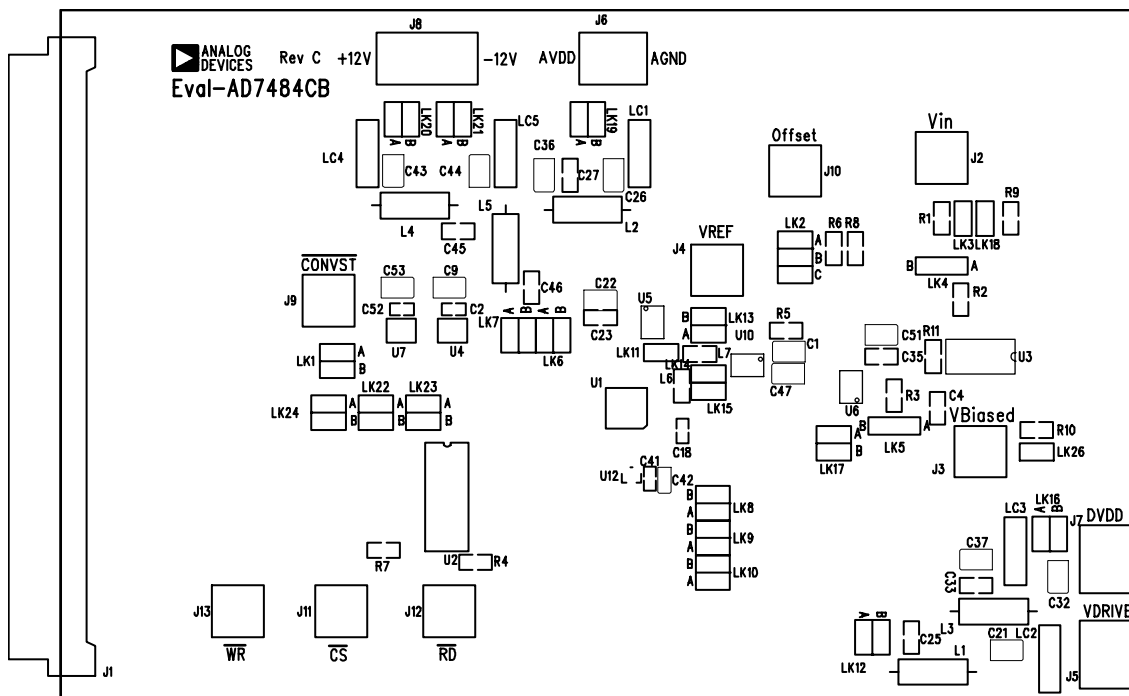

Figure 11. Inner Layer Ground Planes



06246-010

Figure 12. Inner Layer



06246-011

Figure 13. Silkscreen Top Side

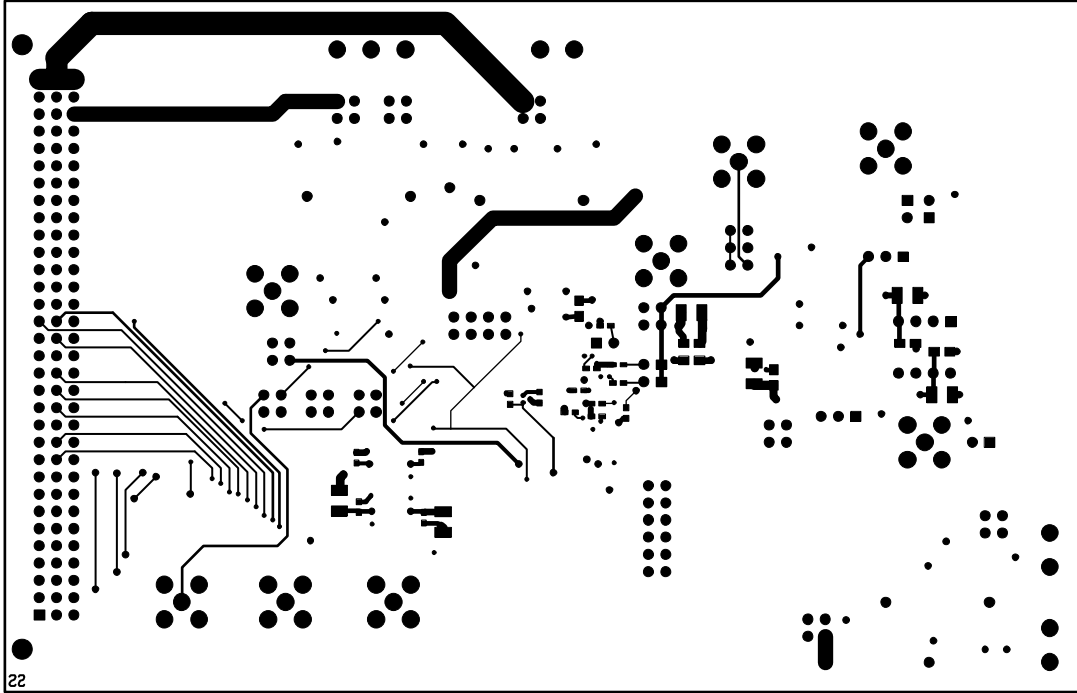

06246-012

Figure 14. Bottom Layer Etch

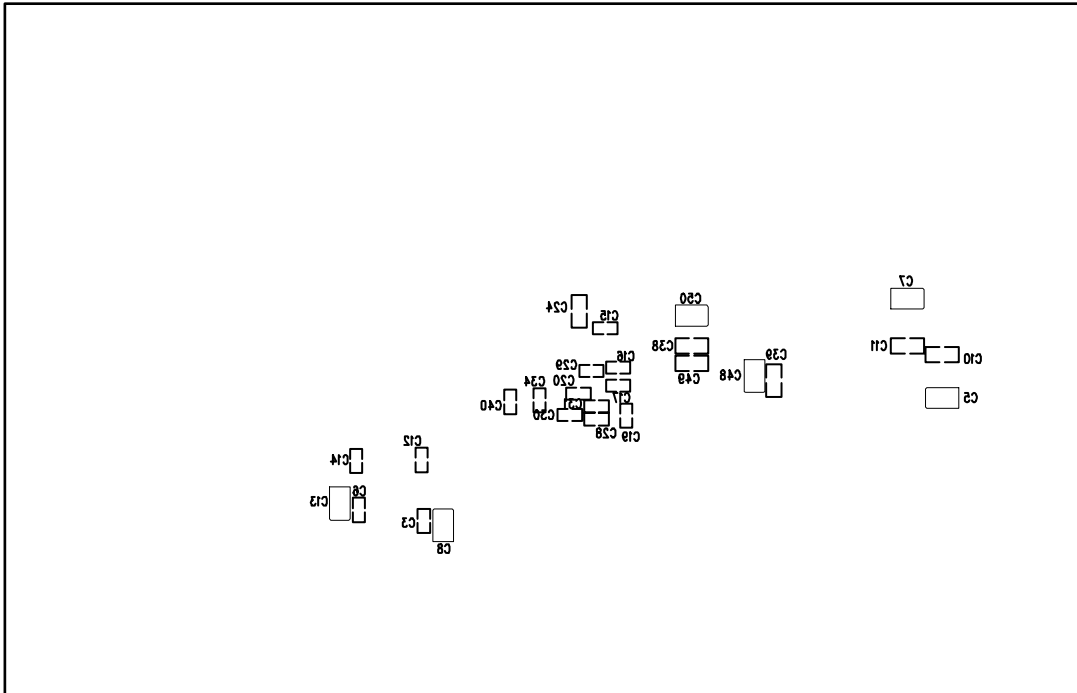

06246-013

Figure 13. Silkscreen Bottom Side, Top View

# ORDERING INFORMATION

## BILL OF MATERIALS

Table 7.

Qty.	Reference Designator	Description	Supplier/ Manufacturer	Order Number <sup>1</sup>
1	U1	AD7484BST	Analog Devices	AD7484BST
1	U2	74FCT162245T	Digi-key	PI74FCT162245ATVE-ND
1	U3	AD829JN	Analog Devices	AD829JN
2	U4, U7	NC7S04M5	Fairchild Semiconductor	FEC 685-914
1	U5	AD780BR	Analog Devices	AD780BR
1	U6	AD8022AR	Analog Devices	AD8022AR
1	U10	AD711KR	Analog Devices	AD711KR
1	U12	ADM809-5LART	Analog Devices	ADM809-5LART
19	C1, C5, C7 to C9, C13, C21, C22, C26, C32, C36, C37, C43, C44, C47, C48, C50, C51, C53	10 $\mu$ F 20 V surface-mount cap (TAJ-B)	AVX	FEC 197-427
16	C2, C3, C6, C12, C14, C18 to C20, C28 to C31, C34, C40, C41, C52	100 nF surface-mount cap (0603 type)	AVX	FEC 317-287
1	C4	470 pF surface-mount cap (0805 type)	AVX	FEC 499-195
12	C10, C11, C23, C25, C27, C33, C35, C38, C39, C45, C46, C49	0.1 $\mu$ F surface-mount cap (0805 type)	AVX	FEC 499-687
1	C24	10 nF surface-mount cap (0805 type)	AVX	FEC 499-225
3	C15 to C17	470 nF surface-mount cap (0603 type)	AVX	FEC 317-275
1	C42	10 $\mu$ F 10 V surface-mount cap (TAJ-A)	Digi-key	TAJR106M010R-ND
5	L1 to L5	Ferrite beads	Multicomp	MCAB 035060-33
2	L6, L7	Surface-mount chip inductors (0805 type)	Ferrox Cube	MLS0805-454-600
5	LC1 to LC5	Surface-mount EMC filters	Murata	NFW31SP206X1E4L
4	R1, R5, R6, R8	1 k $\Omega$ surface-mount resistor (0805 type)	Digi-key	311-1.00KRTR-ND
1	R3	0 $\Omega$ surface-mount resistor (0805 type)	Digi-key	311-0.0ACT-ND
2	R4, R7	100 k $\Omega$ surface-mount resistor (0805 type)	Digi-key	311-100KRTR-ND
2	R9, R10	51 $\Omega$ surface-mount resistor (0805 type)	Digi-key	311-51.0CRTR-ND
1	R2	100 $\Omega$ surface-mount resistor (0805 type)	Digi-key	311-100CRTR-ND
1	R11	150 $\Omega$ surface-mount resistor (0805 type)	Digi-key	311-150CRTR-ND
1	J1	96-pin 90° DIN41612 plug	Harting	0903 196 6921
8	J2 to J4, J9 to J13	Gold 50 $\Omega$ SMB jack	Tyco Electronics	1-1337482-0
3	J5 to J7	2-pin terminal block	Lumberg	KRM 02
1	J8	3-pin terminal block	Lumberg	KRM 03
6	LK3, LK11, LK14, LK15, LK18, LK26	Single jumper	Harwin	M20-9990206
16	LK1, LK6 to LK10, LK12, LK13, LK16, LK17, LK19 to LK24	2-way jumper	Harwin	M20-9980406
1	LK2	3-way jumper	Harwin	M20-9980306
2	LK4, LK5	2-way SIP jumper	Harwin	M20-9990206
26	LK1 to LK26	Shorting link	FCI	65474-002
4	Each Corner	Stick-on feet	3M	SJ5076BLACK
1	EVAL-AD7484CB	PCB	Analog Devices	

<sup>1</sup> FEC = the Farnell Company.

# EVAL-AD7484

## ORDERING GUIDE

Model	Description
EVAL-AD7484CBZ <sup>1</sup>	AD7484 Evaluation Board

<sup>1</sup> Z = RoHS Compliant Part.

## ESD CAUTION



**ESD (electrostatic discharge) sensitive device.** Charged devices and circuit boards can discharge without detection. Although this product features patented or proprietary protection circuitry, damage may occur on devices subjected to high energy ESD. Therefore, proper ESD precautions should be taken to avoid performance degradation or loss of functionality.