



Chipsmall Limited consists of a professional team with an average of over 10 year of expertise in the distribution of electronic components. Based in Hongkong, we have already established firm and mutual-benefit business relationships with customers from,Europe,America and south Asia,supplying obsolete and hard-to-find components to meet their specific needs.

With the principle of “Quality Parts,Customers Priority,Honest Operation,and Considerate Service”,our business mainly focus on the distribution of electronic components. Line cards we deal with include Microchip,ALPS,ROHM,Xilinx,Pulse,ON,Everlight and Freescale. Main products comprise IC,Modules,Potentiometer,IC Socket,Relay,Connector.Our parts cover such applications as commercial,industrial, and automotives areas.

We are looking forward to setting up business relationship with you and hope to provide you with the best service and solution. Let us make a better world for our industry!



Contact us

Tel: +86-755-8981 8866 Fax: +86-755-8427 6832

Email & Skype: info@chipsmall.com Web: www.chipsmall.com

Address: A1208, Overseas Decoration Building, #122 Zhenhua RD., Futian, Shenzhen, China



EVAL-AD7714-3EB

FEATURES

- Operates from a Single +3V Supply**
- On-Board Reference and Digital Buffers**
- Various Linking Options**
- Direct Hook-Up to Printer Port of PC**
- PC Software for Control and Data Analysis**

INTRODUCTION

This Application Note describes the evaluation board for the AD7714-3, 24-Bit signal conditioning ADC. The AD7714 is a complete analog front end for low-frequency applications providing either three fully-differential or five pseudo-differential input channels. The device accepts low-level signals directly from a transducer and outputs a serial digital word. It employs a sigma delta technique to realize up to 24 bits of no missing codes performance. Full data on the AD7714-3 is available in the AD7714 data sheet available from Analog Devices and should be consulted in conjunction with this Application Note when using the Evaluation Board.

Included on the evaluation board, along with the AD7714-3, are an AD589, a +1.23 V precision bandgap reference, a 2.4576MHz crystal and digital buffers to buffer signals to and from the edge connectors.

Interfacing to this board is provided either through a 36-Way Centronics Connector or through a 9-way D-type connector. External sockets are provided for the analog inputs, an external reference input option and an external master clock option.

OPERATING THE AD7714-3 EVALUATION BOARD

Power Supplies

The evaluation board has four power supply input pins: AV_{DD} , $AGND$, DV_{DD} and $DGND$. The AD7714-3 is specified with an AV_{DD} of +3V. Therefore, the AV_{DD} voltage supplied to the board must be +3V. This AV_{DD} voltage is also used to power the AD589 reference. To correctly handle the interface signals the board must be operated from a +3V DV_{DD} voltage also. When using the 36-way Centronics connector to interface the printer port of a PC to the board, the signals at this edge connector are 5V signals. The 74FCT3244T translates these signals to 3V signals for the rest of the logic on the evaluation board. To run the board from a single +3V supply, simply connect the AV_{DD} and DV_{DD} inputs together.

Both $AGND$ and $DGND$ inputs are provided on the board. $AGND$ connects to the AD7714-3 $AGND$ pin and also connects to the GND pin of the AD589. $DGND$ connects to the $DGND$ pin of the AD7714 and to the GND of the digital chips on the board. The $AGND$ and $DGND$ planes are connected at the AD7714. Therefore, it is recommended not to connect $AGND$ and $DGND$ elsewhere in the system to avoid ground loop problems. When using a single supply for both AV_{DD} and DV_{DD} , only one ground connection should be made to the board. This connection should be made to the board's $AGND$ input terminal.

Both supplies are decoupled to their respective ground plane with 10 μ F tantalum and 0.1 μ F ceramic disc capacitors.

FUNCTIONAL BLOCK DIAGRAM

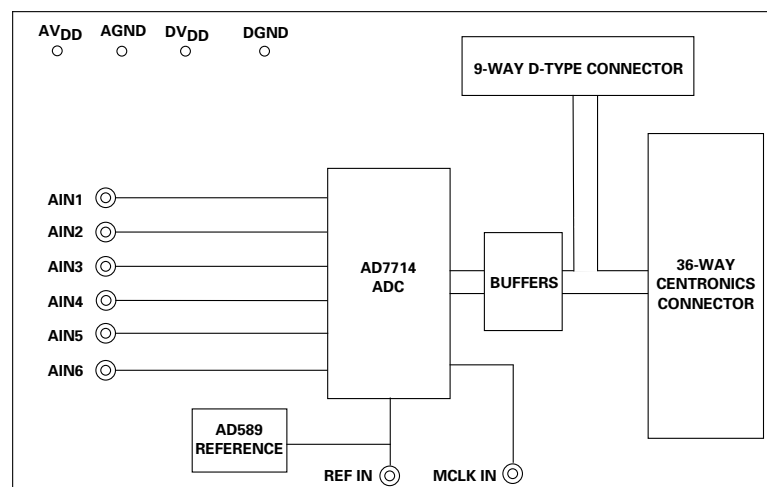

REV. A

Information furnished by Analog Devices is believed to be accurate and reliable. However, no responsibility is assumed by Analog Devices for its use, nor for any infringements of patents or other rights of third parties which may result from its use. No license is granted by implication or otherwise under any patent or patent rights of Analog Devices.

EVAL-AD7714-3EB

Link Options

There are a number of link options on the evaluation board which should be set for the required operating setup before using the board. The functions of these link options are described in detail below.

Link No.	Function
LK1	<p>This option selects the master clock option for the AD7714. The master clock source comes from the on-board crystal or from an external clock source via SKT6. This is a double link and both links must be moved together for correct operation.</p> <p>With both links in position A, the external clock option is selected and an externally applied clock to SKT 6 is routed the MCLK IN pin of the AD7714.</p> <p>With both links in position B, the on-board crystal is selected and provides the master clock for the AD7714.</p>
LK2	<p>This link option is used to determine whether the AD7714 is in its normal operating mode or its $\overline{\text{STANDBY}}$ (power down) mode.</p> <p>With this link in position A, the $\overline{\text{STANDBY}}$ input is connected to a logic high thus configuring the part for normal operation.</p> <p>With this link in position B, the $\overline{\text{STANDBY}}$ pin is connected to a logic low and the AD7714 is placed in its power down mode where its power dissipation is typically 15μW.</p>
LK3	<p>This link option is used to control the buffer option input on the AD7714 (i.e. determine the voltage on the AD7714 BUFFER pin).</p> <p>With this link in position A, a logic high is connected to this input. This connects the on-chip buffer in series with the analog input which allows the inputs to handle higher source impedance.</p> <p>With this link in position B, a logic low is connected to the buffer option select input. With this input low, the on-chip buffer on the analog input is shorted out.</p>
LK4	<p>This link controls the polarity of the serial clock.</p> <p>With this link in position A, the POL pin is connected to a logic high. With this input high, the first transition of the serial clock in a data transfer operation is from a high to a low.</p> <p>With this link in position B, the POL input is connected to a logic low and the first transition of the serial clock in a data transfer operation is from a low to a high.</p>
LK5	<p>This link option is used to select the reference source for the AD7714's REF IN(-) input.</p> <p>With this link in position A, the REF IN(-) pin of the AD7714 is connected directly to AGND.</p> <p>With this link in position B, the REF IN(-) pin of the AD7714 is connected to SKT10. An external voltage connected to SKT10 can now be used for REF IN(-).</p>
LK6	<p>This link option is used to select the reference source for the AD7714's REF IN(+) input.</p> <p>With this link in position A, the REF IN (+) pin of the AD7714 is connected directly to the output of the on-board reference, the AD589.</p> <p>With this link in position B, the REF IN(+) pin of the AD7714 is connected to SKT9. An external voltage connected to SKT 9 can now be used for REF IN(+).</p>
LK7	<p>This link option is not used on the board.</p>
LK8-LK13	<p>These links are in series with the AIN 1 through AIN 6 analog inputs respectively.</p> <p>With these links in place, the analog input on the relevant SKT input is connected directly to the respective AIN input on the part. For example, with LK8 in place, the analog signal applied to SKT7 is connected directly to AIN6 of the AD7714.</p> <p>These links may be removed so that the input signals at the AIN SKTs can be connected to the component grid for signal conditioning before being applied to the analog inputs of the AD7714.</p>

Setup Conditions

Table I shows the position in which all the links are set when the evaluation board is sent out.

Table I. Initial Link Positions

Link No.	Position	Function.
LK1	B	Both links in position B to select the on-board crystal oscillator as the master clock for the board.
LK2	A	Connects $\overline{\text{STANDBY}}$ high and thus configures the part for normal operation.
LK3	B	The on-chip buffer on the AD7714 is shorted out.
LK4	A	Connects POL pin high such that the first transition of the serial clock in a data transfer is from a high to a low.
LK5	A	REF IN(-) connected directly to AGND.
LK6	A	REF IN(+) connected to the output of the on-board AD589 reference.
LK7		No link in place.
LK8-LK13	IN	Connects analog inputs from the input sockets directly to the respective analog input pins of the AD7714.

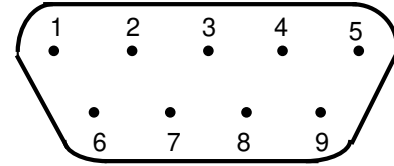

Figure 2. SKT1 Pin Configuration

Table II. SKT1 Pin Designations¹

1	SCLK	Serial Clock. The signal on this pin is buffered before being applied to the SCLK pin of the AD7714.
2	$\overline{\text{DRDY}}$	Logic Output. This is a buffered version of the signal on the AD7714's $\overline{\text{DRDY}}$ pin.
3	$\overline{\text{CS}}$	Chip Select. The signal on this pin is buffered before being applied to the $\overline{\text{CS}}$ pin of the AD7714.
4	$\overline{\text{RESET}}$	Reset Input. The signal on this pin is buffered before being applied to the $\overline{\text{RESET}}$ pin of the AD7714.
5	DIN	Serial Data Input. Data applied to this pin is buffered before being applied to the AD7714's DIN pin.
6	DGND	Ground reference point for digital circuitry. Connects to the DGND plane on the evaluation board.
7	DOUT	Serial Data Output. This is a buffered version of the signal on the AD7714's DOUT pin.
8	DV _{DD}	Digital Supply Voltage. If no DV _{DD} voltage is applied to the board's DV _{DD} input terminal, then the voltage applied to this pin of the connector will supply the DV _{DD} for the evaluation board.
9	$\overline{\text{SYNC}}$	Logic Input. The signal on this pin is buffered before being applied to the $\overline{\text{SYNC}}$ pin of the AD7714.

NOTE

¹An explanation of the AD7714 functions mentioned here is given in Table III as part of the SKT11 pin designations description.

EVALUATION BOARD INTERFACING

Interfacing to the evaluation board is either via a 36-way Centronics connector, SKT11, or a 9-way D-Type connector, SKT1. The pinout for the SKT1 connector is given in Figure 1 and its corresponding pin designations are given in Table II. The pinout for this SKT11 connector is shown in Figure 2 and its pin designations are given in Table III. The evaluation board should be powered up before a cable is connected to either of the connectors.

SKT11 is used to connect the evaluation board to the printer port (parallel port) of a PC. Connection between the two is direct via a standard parallel printer port cable. SKT1 is used to connect the evaluation board to any other system.

EVAL-AD7714-3EB

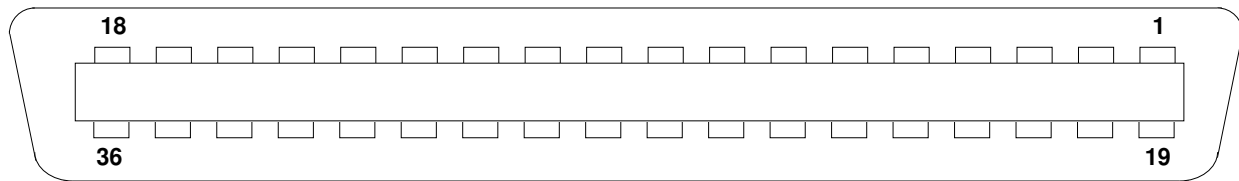

Figure 3. SKT11 Pin Configuration

Table III. SKT11 Pin Designations

1	NC	No Connect. This pin is not connected on the evaluation board.
2	DIN	Serial Data Input. Data applied to this pin is buffered and level-shifted from 5V to 3V before being applied to the AD7714's DIN pin. The serial data applied to the DIN pin is written to the input shift register on the part. Data from this input shift register is transferred to the calibration registers, mode register, communications register or filter selection registers depending on the register selection bits of the Communications Register.
3	$\overline{\text{RESET}}$	Reset Input. The signal on this pin is buffered and level-shifted from 5V to 3V before being applied to the $\overline{\text{RESET}}$ pin of the AD7714. $\overline{\text{RESET}}$ is an active low input which resets the control logic, interface logic, calibration coefficients, digital filter and analog modulator of the part to power-on status.
4	$\overline{\text{CS}}$	Chip Select. The signal on this pin is buffered and level-shifted from 5V to 3V before being applied to the $\overline{\text{CS}}$ pin of the AD7714. $\overline{\text{CS}}$ is an active low logic input used to select the AD7714. With this input hard-wired low, the AD7714 operates in its three-wire interface mode with SCLK, DIN and DOUT used to interface to the device. $\overline{\text{CS}}$ can be used to select the device in systems with more than one device on the serial bus or as a frame synchronisation signal in communicating with the AD7714.
5	SCLK	Serial Clock. The signal on this pin is buffered and level-shifted from 5V to 3V before being applied to the SCLK pin of the AD7714. An external serial clock is applied to this input to access serial data from the AD7714. This serial clock can be a continuous clock with all data transmitted in a continuous train of pulses. Alternatively, it can be a non-continuous clock with the information being transmitted to the AD7714 in smaller batches of data.
6	$\overline{\text{SYNC}}$	Logic Input. The signal on this pin is buffered and level-shifted from 5V to 3V before being applied to the $\overline{\text{SYNC}}$ pin of the AD7714. The $\overline{\text{SYNC}}$ input allows for synchronisation of the digital filters and analog modulators across a number of AD7714s. While $\overline{\text{SYNC}}$ is low, the nodes of the digital filter, the filter control logic and the calibration control logic are reset and the analog modulator is also held in its reset state.
7-8	NC	No Connect. These pins are not connected on the evaluation board.
9	DV _{DD}	Digital Supply Voltage. This provides the supply voltage for IC4, the buffer chip which buffers the output signals from the AD7714 before they are applied to SKT11.
10	$\overline{\text{DRDY}}$	Logic output. This is a buffered version of the signal on the AD7714's $\overline{\text{DRDY}}$ pin. A logic low on the $\overline{\text{DRDY}}$ output indicates that a new output word is available from the AD7714 data register. The $\overline{\text{DRDY}}$ pin will return high upon completion of a read operation of a full output word. If no data read has taken place, after an output update, the $\overline{\text{DRDY}}$ line will return high for $500 \cdot t_{\text{CLK IN}}$ cycles prior to the next output update. This gives an indication of when a read operation should not be attempted to avoid reading from the data register as it is being updated. $\overline{\text{DRDY}}$ is also used to indicate when the AD7714 has completed its on-chip calibration sequence.
11-12	NC	No Connect. These pins are not connected on the evaluation board.
13	DOUT	Serial Data Output. This is a buffered version of the signal on the AD7714's DOUT pin. Serial data from the output shift register on the part is clocked out on this pin. This output shift register can contain information from the calibration registers, mode register, communications register, filter selection registers or data register depending on the register selection bits of the Communications Register.
14-18	NC	No Connect. These pins are not connected on the evaluation board.
19-30	DGND	Ground reference point for digital circuitry. Connects to the DGND plane on the evaluation board.
31-36	NC	No Connect. These pins are not connected on the evaluation board.

SOCKETS

There are eleven sockets on the AD7714-3 evaluation board. The function of these sockets is outlined in Table IV.

Table IV. Socket Functions

Socket	Function
SKT1	9-Way D-Type Connector which can be used for digital interfacing to the evaluation board.
SKT2	Sub-Minature BNC Connector. The analog input signal for the AIN1 input of the AD7714 is applied to this socket.
SKT3	Sub-Minature BNC Connector. The analog input signal for the AIN2 input of the AD7714 is applied to this socket.
SKT4	Sub-Minature BNC Connector. The analog input signal for the AIN3 input of the AD7714 is applied to this socket.
SKT5	Sub-Minature BNC Connector. The analog input signal for the AIN4 input of the AD7714 is applied to this socket.
SKT6	Sub-Minature BNC Connector. The master clock signal for the MCLK IN input of the AD7714 is applied to this socket when the board is configured for an externally-applied master clock.
SKT7	Sub-Minature BNC Connector. The analog input signal for the AIN6 input of the AD7714 is applied to this socket.
SKT8	Sub-Minature BNC Connector. The analog input signal for the AIN5 input of the AD7714 is applied to this socket.
SKT9	Sub-Minature BNC Connector. The reference voltage for the REF IN(+) input of the AD7714 is applied to this socket when the board is configured for an externally-applied reference voltage.
SKT10	Sub-Minature BNC Connector. The reference voltage for the REF IN(-) input of the AD7714 is applied to this socket when the board is configured for an externally-applied reference voltage.
SKT11	36-Way Centronics Connector which can be used for digital interfacing to the evaluation board. This connector should be used when connecting the board to the parallel printer port of the PC to use the evaluation software.

RUNNING THE AD7714 INTERFACE SOFTWARE.

Included in the evaluation board package is a PC-compatible disk which contains software for controlling and evaluating the performance of the AD7714 using the printer port of a PC. There are two files on the disk, an executable file and a "README" text file which gives details of the functions available in the executable program. The executable program runs under DOS and it is advised that the user copies this file to the system hard disk to obtain optimum performance from the software.

To run the evaluation software simply run the executable file. The program provides a number of different menu-type screens, each screen containing several function options. On each of these menu-screens the user can choose the function by pressing the associated number key or click on the required option using the mouse. Alternatively, the user can scroll up or down the screen using the arrow keys to the required function and then hit the RETURN key. The "README" file gives a detailed description of each of the menus and the procedure to use the software to evaluate the board. A brief description of the procedure is outlined below.

PC Configuration

The first menu gives options on the type of PC being used. The printer port needs to be configured correctly for one of the many different PC-types for interfacing to the AD7714. Choose the required printer type from the menu. The next menu gives options on the port address to be used. Choose the required port address. The PC printer port is now configured for operation with the AD7714 evaluation board.

AD7714 Configuration

The next menu in the sequence is the **Main Menu** which contains 6 options. These allow reading from the data register, configuration of the communications register, file options (read and write data to files), noise analysis, printer port setup and resetting the AD7714.

The first option to select in this **Main Menu** is option 1 (**Communications Register**). This calls up the **Comms Register Menu** which has 8 options.

The first option to select in the **Comms Register Menu** is option 0 (**Channel Selection**) which allows the user to set up the required analog input channel. After selecting the desired channel pair in the **Channel Configuration Menu**, the program returns to the **Main Menu**. Select option 1 (**Filter Registers**) which allows the user to enter the clock frequency being used, program the filter cutoff, data word length required and bipolar or unipolar operation.

After selecting all the required parameters in the **Filter Registers Menu**, choose option 6 (**Exit**) to return to the **Comms Register Menu**. In this menu select option 2 (**Mode Register**). This brings up the **Mode Register Menu** which allows the gain of the PGA to be programmed, turns on/off the burnout current, allows software filter synchronization and allows the various calibration modes to be selected. Calibration should be the last operation to be completed. When calibration is complete, choose option 9 (**Exit**) to return to the **Comms Register Menu**. All parameters on the part should now be set up, so choose option 8 (**Exit**) to return to the **Main Menu**.

From the **Main Menu** select the option 0 (**Read from Data Register**). The number of readings required is prompted and as the read operation proceeds the value read from the AD7714's data register is displayed on the screen.

Data Analysis

When all the data has been read, the program returns the user to the **Main Menu**. It is possible to write the data which has been read to a file by selecting option 2 (**Files Option**) or analyze the data by selecting option 3 (**Do Noise Analysis**). The **Noise Menu** allows the user to get statistical results from the data, to plot the raw data, plot a histogram of the data on the screen or perform a rolling average on the data. To return to the **Main Menu** from the **Noise Menu** choose option 5 (**Exit**).

EVAL-AD7714-3EB

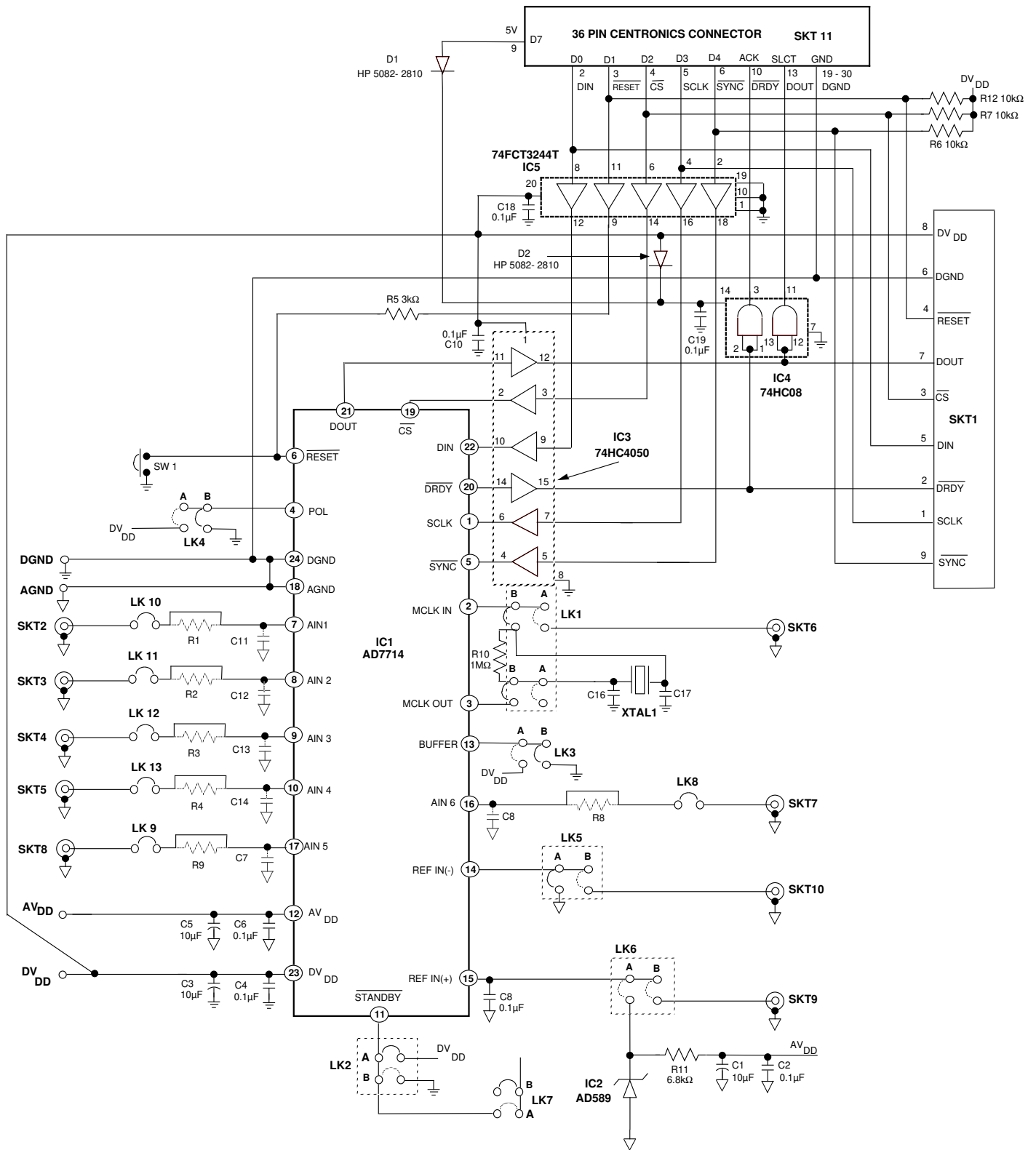

Figure 3. AD7714-3 Evaluation Board Circuit Diagram

COMPONENT LISTING AND MANUFACTURERS

Integrated Circuits

Component	Location	Vendor
AD7714	IC1	Analog Devices
AD589	IC2	Analog Devices
74HC4050	IC3	Motorola
74HCT08	IC4	Motorola
74FCT3244T	IC5	Integrated Device Technology
HP 5082-2810	D1 & D2	Hewlett Packard

Capacitors

Component	Location	Vendor
10 μ F \pm 20% Tantalum (16 V)	C1, C3, C5	AVX- Kyocera Mftrs No TAG106MO16
0.1 μ F Ceramic(X7R \pm 20%)	C2, C4, C6, C9, C10, C15, C18, C19	Philips Mftrs No. CW20C 104M
33pF \pm 2% Ceramic	C16, C17	Philips Mftrs No. 683 34339
Open Circuit	C7, C8, C11, C12, C13, C14	

Resistors

Component	Location	Vendor
10k Ω \pm 5% 0.25W Carbon Film Resistor	R5, R6, R7, R12	Bourns
1M Ω \pm 5% 0.25W Carbon Film Resistor	R10	Bourns
Short Circuits	R1, R2, R3, R4, R8, R9	
6.8k Ω \pm 5% 0.25W Carbon Film Resistor	R11	Bourns

Link Options

Component	Location	Vendor
Pin Headers	Lk1 (4x2 way) Lk2, Lk3, Lk4, Lk5, Lk6 (2x2 way) Lk8, Lk9, Lk10, Lk11, Lk12, Lk13 (1x2 way)	Harwin Mftrs No. M20-9993606
Shorting Plugs	Pin Headers (14 required)	Harwin Mftrs No. M7571-05

EVAL-AD7714-3EB

Switch

Component	Location	Vendor
Push Button Switch	SW1	Omron Mftrs No. B3F1000

Sockets

Component	Location	Vendor
Miniature BNC Connectors	SKT2 - SKT 10	M/A - Com Greenpar Mftrs No. C65N07G999X99
9-Way D-Type Connector	SKT1	McMurdo Mftrs No. SDE9PNTD
36 Way Centronics Connector	SKT 11	Fujitsu Mftrs No. FCN785J036G0
24-Pin IC Socket	IC1	Harwin
16-Pin IC Socket	IC3	xx = No. of Pins
14- Pin IC Socket	IC4	
20-Pin IC Socket	IC5	
Wire Wrap Pins	DGND, AGND, AVDD, DVDD	Bicc Vero Mftrs No. 663472C

Crystal Oscillator

Component Identification	Location	Vendor
2.4576MHz Oscillator	Xtal 1	IQD Mftrs No. A166C