



Chipsmall Limited consists of a professional team with an average of over 10 year of expertise in the distribution of electronic components. Based in Hongkong, we have already established firm and mutual-benefit business relationships with customers from,Europe,America and south Asia,supplying obsolete and hard-to-find components to meet their specific needs.

With the principle of “Quality Parts,Customers Priority,Honest Operation,and Considerate Service”,our business mainly focus on the distribution of electronic components. Line cards we deal with include Microchip,ALPS,ROHM,Xilinx,Pulse,ON,Everlight and Freescale. Main products comprise IC,Modules,Potentiometer,IC Socket,Relay,Connector.Our parts cover such applications as commercial,industrial, and automotives areas.

We are looking forward to setting up business relationship with you and hope to provide you with the best service and solution. Let us make a better world for our industry!



Contact us

Tel: +86-755-8981 8866 Fax: +86-755-8427 6832

Email & Skype: info@chipsmall.com Web: www.chipsmall.com

Address: A1208, Overseas Decoration Building, #122 Zhenhua RD., Futian, Shenzhen, China



Evaluating the **AD7903** Dual Differential, 16-Bit, 1 MSPS PuSAR ADC

FEATURES

Full featured evaluation board for the **AD7903**
Versatile analog signal conditioning circuitry
On-board reference, reference buffers, and ADC drivers
System demonstration board compatible (**EVAL-SDP-CB1Z**)
PC software for control and data analysis of time and frequency domain

EVALUATION KIT CONTENTS

EVAL-AD7903SDZ evaluation board
Wall power supply 9 V dc adapter
Daughter card power connector

ADDITIONAL EQUIPMENT/SOFTWARE NEEDED

System demonstration platform (**EVAL-SDP-CB1Z**)
Precision analog signal source
Power supply, +7 V/–2.5 V (optional)
USB cable
SMA cable
PC running Windows XP SP2, Windows Vista, Windows 7, or higher with USB 2.0 port
Evaluation software for the **AD7903** (download from **AD7903** product page)

ONLINE RESOURCES

Documents Needed

[AD7903](#) data sheet
[EVAL-AD7903SDZ](#) user guide

Required Software

[EVAL-AD7903SDZ](#) evaluation software
[FAQs and Troubleshooting](#)

TYPICAL SETUP

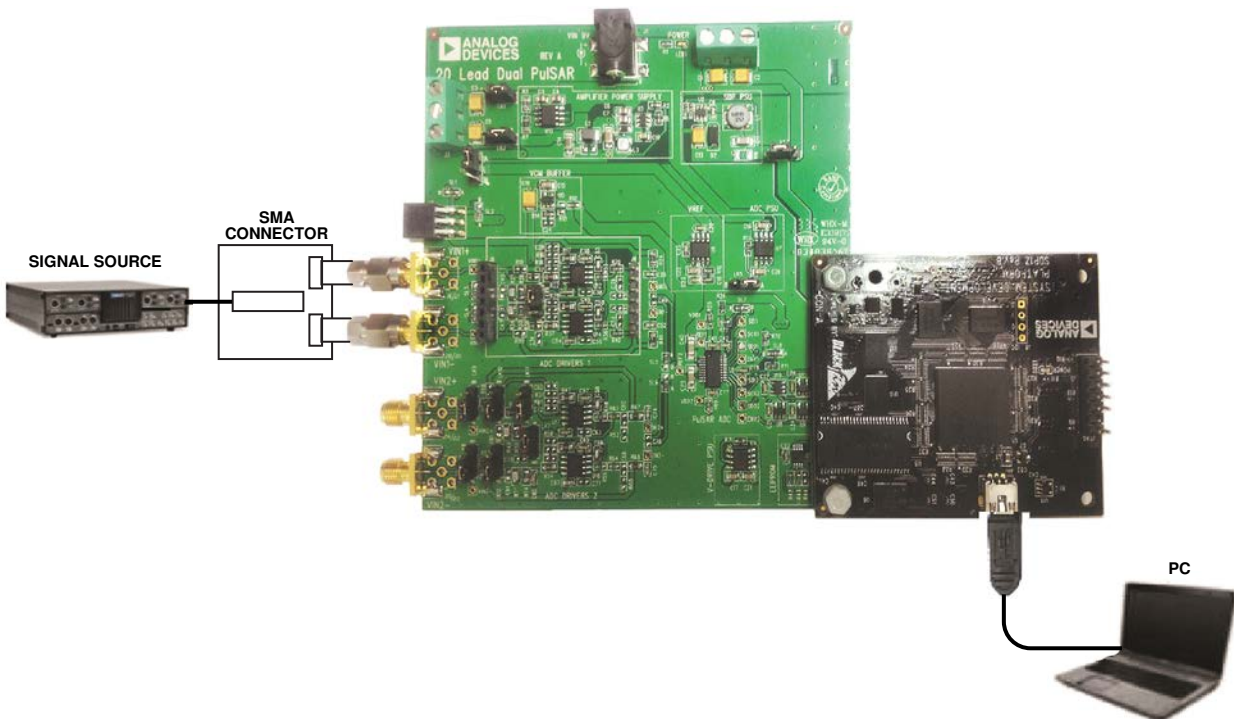

Figure 1. Typical Setup for the **EVAL-AD7903SDZ**
(**EVAL-AD7903SDZ** on Left and **EVAL-SDP-CB1Z** on Right)

11800-001

TABLE OF CONTENTS

Features	1	Modes of Operation	12
Evaluation Kit Contents.....	1	SDP Controlled Mode	12
Additional Equipment/Software Needed	1	Standalone Mode.....	12
Online Resources	1	How to Use the Software	13
Typical Setup	1	Setting Up the System for Data Capture:	
Revision History	2	Board Operation/Connection Sequence.....	13
General Description	3	Starting the Software.....	13
Getting Started	4	Overview of the Main Window.....	15
Software Installation Procedures.....	4	Generating a Waveform Analysis Report.....	16
Evaluation Board Setup Procedures.....	7	Generating a Histogram of the ADC Code Distribution	17
Evaluation Board Hardware.....	8	Generating a Fast Fourier Transform of AC Characteristics	18
Device Description.....	8	Generating a Summary of the Waveform, Histogram, and	
Power Supplies	8	Fast Fourier Transform.....	19
Link Configuration Options	10	Evaluation Board Schematics and Artwork.....	20
Evaluation Board Circuitry	11	EVAL-AD7903SDZ Schematics	20
Analog Inputs.....	11	EVAL-AD7903SDZ Layout.....	25
Reference	11	Bill of Materials.....	28
Serial Interface	11	Related Links.....	30

REVISION HISTORY

1/14—Revision 0: Initial Version

GENERAL DESCRIPTION

The [EVAL-AD7903SDZ](#) is an evaluation board designed to demonstrate the low power [AD7903](#) performance and to provide an easy to understand interface for a variety of system applications. The [AD7903](#) is a dual differential 16-bit, 1 MSPS PulSAR® ADC. A full description of the [AD7903](#) is available in the [AD7903](#) data sheet and should be consulted when using this evaluation board.

The evaluation board is ideal for use with the Analog Devices, Inc., system demonstration platform (SDP) board, [EVAL-SDP-CB1Z](#). The evaluation board interfaces to the SDP board via a 120-pin

connector. SMA Connectors J6, J7, J10, and J15 are provided to connect a low noise analog signal source.

The user PC software executable controls the evaluation board over the USB through the SDP board, [EVAL-SDP-CB1Z](#).

On-board components include the following:

[ADR435](#): high precision, buffered band gap 5.0 V reference

[AD8031](#): reference buffer

[ADA4841-1](#): signal conditioning circuit with op amps

[ADP7104](#) and [ADP2301](#): regulators to derive necessary voltage levels on board

GETTING STARTED

SOFTWARE INSTALLATION PROCEDURES

The evaluation board software can be downloaded from the [AD7903](#) product page on the Analog Devices website, at www.analog.com.

There are two parts to the installation:

- [AD7903](#) evaluation board software installation
- [EVAL-SDP-CB1Z](#) system demonstration platform board drivers installation

Warning

The evaluation board software and drivers must be installed before connecting the evaluation board and [EVAL-SDP-CB1Z](#) board to the USB port of the PC to ensure that the evaluation system is correctly recognized when it is connected to the PC.

Installing the [AD7903](#) Evaluation Board Software

To install the [AD7903](#) evaluation board software,

1. Start the Windows operating system and download the software from the [AD7903](#) product page on the Analog Devices website, at www.analog.com.
2. Unzip the downloaded file.
3. Double-click the **setup.exe** file to begin the evaluation board software installation (see Figure 2).



Figure 2. [AD7903](#) Evaluation Board Software Installation: Installation Begins

4. Select the location to install the software, and then click **Next**. (The default location is **C:\Program Files (x86)\Analog Devices\AD7902_03 Evaluation Software**. This location also contains the executable software and example files.)

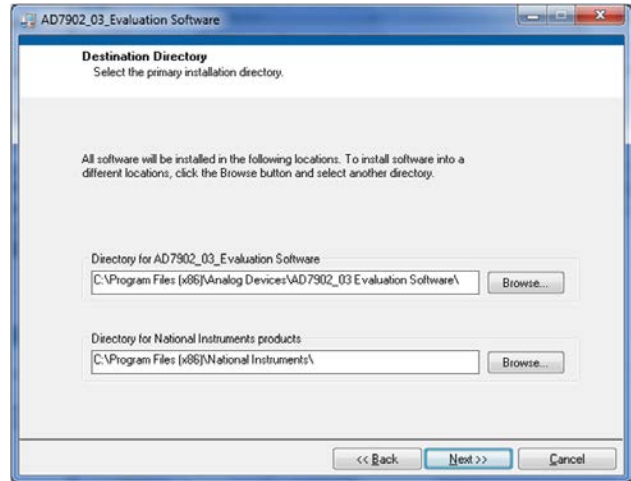

Figure 3. [AD7903](#) Evaluation Board Software Installation: Selecting the Location for Software Installation (the Default Location Is Shown)

5. A license agreement appears. Read the agreement, and then select **I accept the License Agreement** and click **Next**.

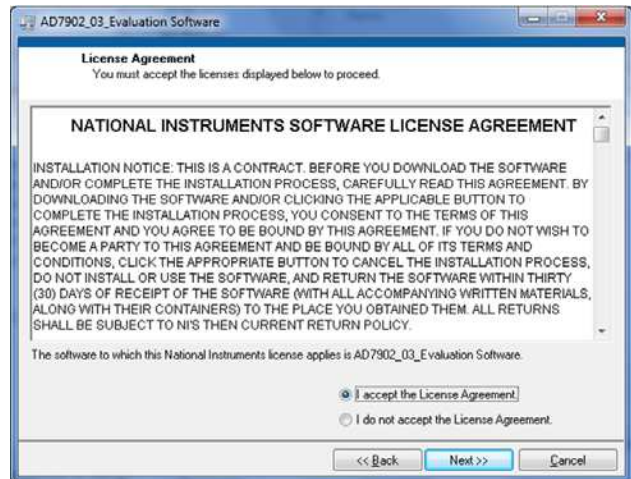

Figure 4. [AD7903](#) Evaluation Board Software Installation: Accepting the License Agreement

- A summary of the installation is displayed. Click **Next** to continue.

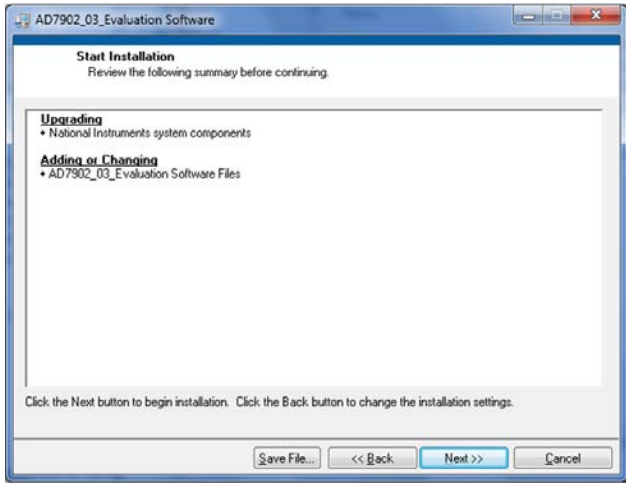

Figure 5. AD7903 Evaluation Board Software Installation: Reviewing a Summary of the Installation

- A dialog box shows the installation progress.

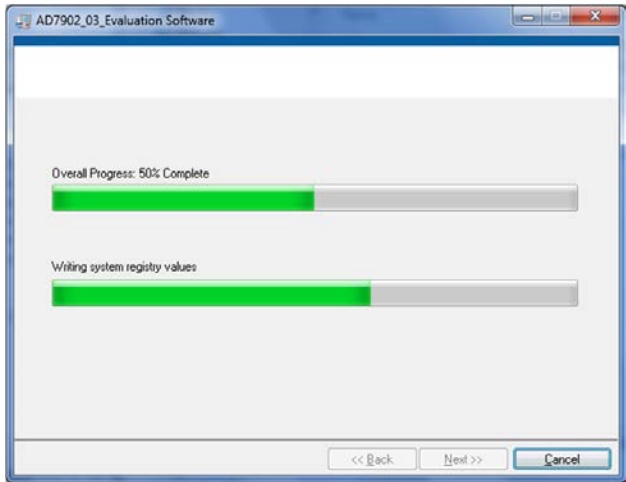

Figure 6. AD7903 Evaluation Board Software Installation: Displaying Installation Progress

- The dialog box informs you when the installation is complete. Click **Next**.

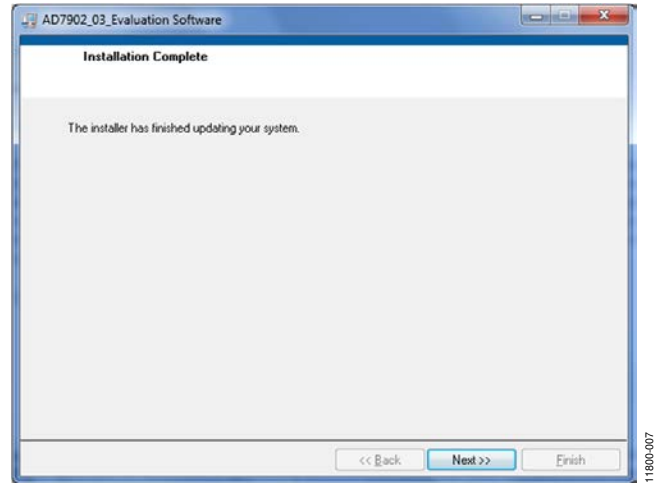

Figure 7. AD7903 Evaluation Board Software Installation: Indicating When the Installation Is Complete

- The setup for the installation of the **EVAL-SDP-CB1Z** system demonstration platform board drivers automatically begins to load.



Figure 8. Loading the Setup for SDP Drivers Installation

Installing the EVAL-SDP-CB1Z System Demonstration Platform Board Drivers

After the installation of the evaluation board software is complete, a welcome window is displayed for the installation of the **EVAL-SDP-CB1Z** system demonstration platform board drivers.

- Make sure that all other applications are closed, and then click **Next**.



Figure 9. EVAL-SDP-CB1Z Drivers Setup: Beginning the Drivers Installation

2. Select the location to install the drivers, and then click **Install**.



Figure 10. EVAL-SDP-CB1Z Drivers Setup: Selecting the Location for Drivers Installation

3. Installation of the SDP drivers begins.

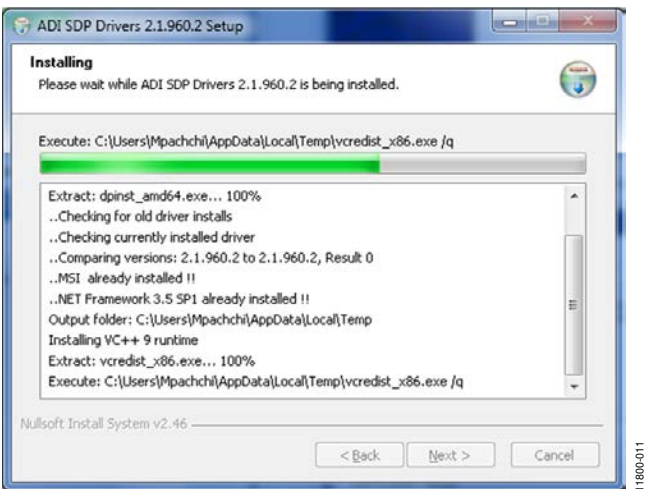

Figure 11. EVAL-SDP-CB1Z Drivers Setup: Beginning the Installation

4. A dialog box appears asking whether you would like to install this device software. Click **Install** to confirm that you would like to install the drivers.



Figure 12. EVAL-SDP-CB1Z Drivers Setup: Granting Permission to Install Drivers

5. To complete the drivers installation, click **Finish**, which closes the installation wizard.



Figure 13. EVAL-SDP-CB1Z Drivers Setup: Completing the Drivers Setup Wizard

6. Before using the evaluation board, you must restart your computer. A dialog box opens, giving you the following options: **Restart**, **Shut Down**, **Restart Later**. Click the appropriate button.



Figure 14. EVAL-SDP-CB1Z Drivers Setup: Restarting the Computer

EVALUATION BOARD SETUP PROCEDURES

The AD7903 evaluation board connects to the (EVAL-SDP-CB1Z) system demonstration board. The EVAL-SDP-CB1Z board is the controller board, which is the communication link between the PC and the main evaluation board.

Figure 1 shows a photograph of the connections made between the EVAL-AD7903SDZ daughter board and the EVAL-SDP-CB1Z motherboard.

Connecting the Evaluation and SDP Boards to a PC

1. Install the AD7903 software. Ensure that the EVAL-SDP-CB1Z board is disconnected from the USB port of the PC while installing the software. The PC must be restarted after the installation is complete.
2. Before connecting power, connect the 120-pin connector, J5, of the EVAL-AD7903SDZ board to Connector J4 on the EVAL-SDP-CB1Z board. Nylon screws are included in the EVAL-AD7903SDZ evaluation kit and can be used to ensure that the EVAL-AD7903SDZ and EVAL-SDP-CB1Z boards are connected firmly together.
3. Connect the 9 V power supply adapter included in the kit to the EVAL-SDP-CB1Z.
4. Connect the EVAL-SDP-CB1Z board to the PC via the USB cable. (If you are using Windows® XP, you may need to search for the EVAL-SDP-CB1Z drivers. Choose to automatically search for the drivers for the EVAL-SDP-CB1Z board if prompted by the operating system.)

Verifying the Board Connection

1. Allow the **Found New Hardware Wizard** to run after the EVAL-SDP-CB1Z board is plugged into your PC. (If you are using Windows XP, you may need to search for the EVAL-SDP-CB1Z drivers. Choose to automatically search for the drivers for the EVAL-SDP-CB1Z board if prompted by the operating system.)
2. Check that the board is connected to the PC correctly using the **Device Manager** of the PC.
 - a. Access the **Device Manager** as follows:
 - i. Right-click **My Computer** and then click **Manage**.
 - ii. A dialog box appears asking for permission to allow the program to make changes to your computer. Click **Yes**.
 - iii. The **Computer Management** box appears. From the list of **System Tools**, click **Device Manager**.
 - b. Under **ADI Development Tools**, **Analog Devices System Development Platform SDP-B** should appear (see Figure 15), indicating that the EVAL-SDP-CB1Z driver software is installed and that the board is connected to the PC correctly.

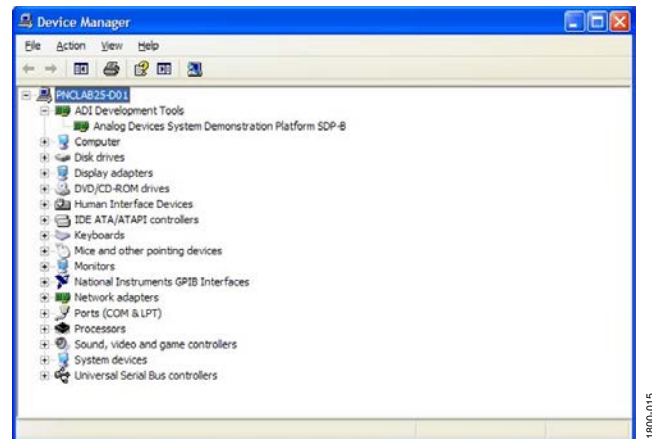

Figure 15. Device Manager:
Checking that the Board Is Connected to the PC Correctly

EVALUATION BOARD HARDWARE

DEVICE DESCRIPTION

The [AD7903](#) is a 16-bit, 1 MSPS, precision, power efficient, dual differential PulSAR ADC that uses SAR-based architecture and does not exhibit any pipeline delay or latency. The [AD7903](#) is specified for use with a single supply of 2.5 V (V_{DD1} , V_{DD2}). The interface from the digital host to the [AD7903](#) uses 1.8 V/2.5 V/3.3 V/5.5 V logic. The [AD7903](#) is compatible with the SPI/QSPI/MICROWIRE/DSP serial interface to transfer data conversions. Complete [AD7903](#) specifications are provided in the [AD7903](#) data sheet and should be consulted in conjunction with this user guide when using the evaluation board. Full details on the [EVAL-SDP-CB1Z](#) are available on the Analog Devices website, at www.analog.com.

Figure 26 to Figure 31 show the evaluation board schematics. The board consists of an [AD7903](#) ADC (U1) with a reference (U6—[ADR435](#)), and several ADC drivers (U12, U14, U16, and U17—[ADA4841-1YRZ](#)). The evaluation board is a flexible design that enables you to adjust compensation components and operate the evaluation board from an adjustable bench top power supply.

POWER SUPPLIES

The evaluation board can be powered from a wall adapter or from a bench top power supply. By default, the board is set up to operate from a 9 V wall adapter using the on-board power supplies described in Table 1.

Table 1. Power Supplies Provided on the Board

Power Supply (V)	Function	Components Used
+5	SDP power	ADP2301
+7.5	Positive rail	ADP7104
-2.5	Negative rail	ADP2301
+2.5	ADC V_{DD} rail	ADP7104
+3.3	V_{DRIVE} (digital power)	ADP7104

Each on-board power supply is decoupled where it enters the board as well as where it connects to each device. A single ground plane is used on this board to minimize the effect of high frequency noise interference.

Alternatively, the board can be powered from a bench top power supply by using the J2 and J3 screw terminals and changing the SL1 to SL4 and LK3 to LK5 solder link settings to Position B (see Table 2). When bench top power is used, use of the wall adapter and the on-board power supplies are no longer required.

Table 2. Solder Links—Settings for Bench Top Power Supply¹

Link	Setting	Function
SL1	B	+ V_S
SL2	B	- V_S
SL3	B	- V_S
SL4	B	+ V_S
LK3	B	V_{SDP}
LK4	B	V_{REF}
LK5	B	V_{DD} for ADC

¹ All other solder link settings are as described in Table 3.

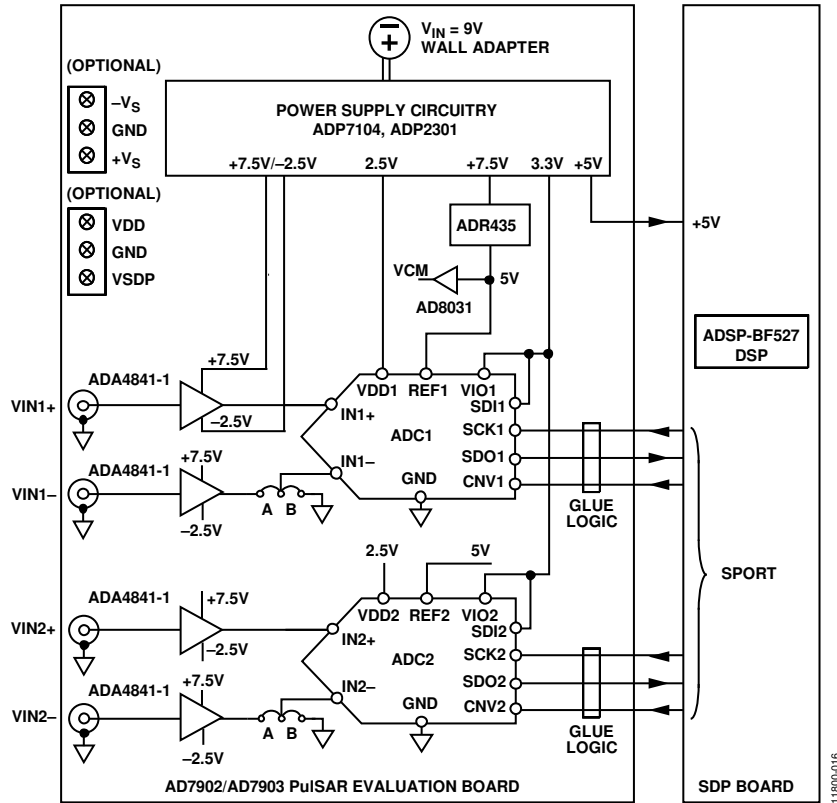

Figure 16. Simplified Evaluation Board Functional Block Diagram

11880C-016

LINK CONFIGURATION OPTIONS

Care should be taken before applying power and signals to the evaluation board to ensure that all link positions are as required by the operating mode. There are two modes in which to operate the evaluation board. The evaluation board can be operated in SDP controlled mode to be used with the SDP board, or the evaluation board can be used in standalone mode.

When operating in SDP controlled mode, ensure that VIO is 3.3 V. Operating with a VIO greater than 3.3 V in SDP controlled mode may damage the SDP board.

The Default Position column of Table 3 shows the default positions in which the links are set when the evaluation board is packaged. When the board is shipped, it is assumed that you are going to operate the evaluation board with the SDP board (SDP controlled mode).

Table 3. Solder Links—Factory Default Settings

Link	Setting	Function	Comment
SL1	A	+V _S	Change to B if using bench supplies.
SL2	A	-V _S	Change to B if using bench supplies.
SL3	A	-V _S	Change to B if using bench supplies.
SL4	A	+V _S	Change to B if using bench supplies.
SL5	A	Analog input	Do not alter.
SL6	A	Analog input	Do not alter.
LK3	A	V _{SDP}	Change to B if using bench supplies.
LK4	A	V _{REF}	Change to B if using bench supplies.
LK5	A	V _{DD} for ADC	Change to B if using bench supplies.
LK6	A	U12 output connects to U14 input	Change to B if U14 inverting input needs to be connected to ground.
LK7	A	U17 output connects to U16 input	Change to B if U16 inverting input needs to be connected to ground.
LK8	A	ADC2 input	Change to B if using ADC1 input.
LK9	A	ADC2 input	Change to B if using ADC1 input.
LK10	A	U17 input	Change to B if U17 needs to be bypassed.
LK11	A	U17 input	Change to B if U17 needs to be bypassed.
LK12	A	U16 input	Change to B if U16 needs to be bypassed.

EVALUATION BOARD CIRCUITRY

ANALOG INPUTS

The analog inputs to the evaluation board are SMA Connectors J6, J7, J10, and J15. These inputs are buffered with dedicated amplifier circuitry (U12, U14, U16, and U17), as shown in Figure 26 and Figure 27. The circuit not only allows different configurations, input range scaling, and filtering but also allows adding a dc component and using different op amps and supplies. The analog input amplifiers are set as unity-gain buffers by factory default. The amplifier positive rail is driven from 7.5 V (from U13—[ADP7104](#)). The negative amplifier rail is driven from $-V_s$ (generated by U3—[ADP2301](#)).

The default configuration sets all op amps (U12, U14, U16, and U17) at midscale, generated from a buffered reference voltage divider (VCM).

The evaluation board is configured by factory default for providing a differential analog input path to ADC1 and ADC2 (see Figure 16).

For dynamic performance, an FFT test can be done by applying a very low distortion ac source.

For low frequency testing, the audio precision source can be used directly because its outputs are isolated. Set the outputs for

a balanced and floating ground. Different sources can be used; however, most are single-ended sources that use a fixed output resistance.

By default, the evaluation board uses the amplifiers as unity-gain buffers. The noninverting input has a common-mode adjustment that involves a 49.9 k Ω shunt resistor. This resistor creates a voltage divider with the source, which must be accounted for when using the board.

REFERENCE

An external 5 V reference (U6—[ADR435](#)) is used to supply the ADCs directly.

SERIAL INTERFACE

The evaluation board uses the SPORT interface from the [ADSP-BF527](#) DSP.

Multiple AND gates (U9, U10, and U11) are used to clock and gate the SPORT transfer to the ADC device.

MODES OF OPERATION

SDP CONTROLLED MODE

The [AD7903](#) uses a high speed serial interface that allows sampling rates of up to 1 MSPS. For more information about the operation of the serial interface, refer to the [AD7903](#) data sheet.

The [AD7903](#) uses the serial interface to transfer data to the [EVAL-SDP-CB1Z](#).

The [EVAL-AD7903SDZ](#) communicates with the [EVAL-SDP-CB1Z](#) board using level shifters. The [EVAL-SDP-CB1Z](#) operates at a 3.3 V logic level, which allows logic voltages that exceed 3.3 V to be used without damaging the SDP interface.

STANDALONE MODE

The [EVAL-AD7903SDZ](#) can also be used without the [EVAL-SDP-CB1Z](#) controller board. In this case, the [EVAL-AD7903SDZ](#) is connected to the serial interface using the J5 connector or the test points. For more information about the operation of the serial interface, refer to the [AD7903](#) data sheet.

HOW TO USE THE SOFTWARE

SETTING UP THE SYSTEM FOR DATA CAPTURE: BOARD OPERATION/CONNECTION SEQUENCE

With the evaluation software installed, the following board operation/connection sequence can be used:

1. Connect the SDP controller board to the evaluation board with the J5 connector (screw into place as required). The software is configured to find the evaluation board on either the J4 or J5 connector of the SDP board.
2. Power the board with the appropriate supply, as described in the Power Supplies section.
3. Connect the [EVAL-SDP-CB1Z](#) board to a PC using the USB cable.
4. Start the evaluation software. Click **Start > All Programs > AD7903_03_Evaluation > AD7903_03_Evaluation_Software**.
5. Apply a signal source and capture data.

STARTING THE SOFTWARE

When the software starts running, it searches for hardware connected to the PC. The software automatically detects the generic attached to the PC, or you can choose to run the software in standalone mode without any hardware connected.

With Hardware Connected

To run the program with hardware connected,

1. Click **Start > All Programs > AD7903_03_Evaluation > AD7903_03_Evaluation_Software**. (To uninstall the program, click **Start > Control Panel > Add or Remove Programs > AD7903_03_Evaluation**.)
2. If the SDP board is not connected to the USB port when the software is launched, a connectivity error displays (see Figure 17). If a connectivity error is displayed, connect the evaluation board to the USB port of the PC, wait a few seconds, click **Rescan**, and follow the instructions.



Figure 17. SDP Board Not Connected to the USB Port Pop-Up Window Error

3. After finding the evaluation board, the software connects to the board and displays the dialog box shown in Figure 18.

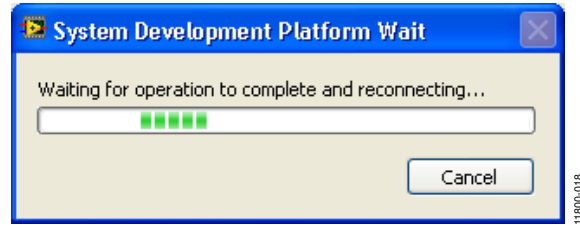

Figure 18. Software Connects to SDP Board

4. After the board is correctly detected, the main window of the software appears (see Figure 21), showing that the [EVAL-AD7903SDZ](#) board is connected.

Without Hardware Connected

The software can run in standalone mode when no evaluation board hardware is connected to the USB port.

1. Click **Start > All Programs > AD7903_03_Evaluation > AD7903_03_Evaluation_Software**.
2. The software automatically seeks to find the hardware connected; therefore, when no hardware is connected, a connectivity error is displayed (see Figure 19). If you wish to continue without hardware in standalone mode, click **Cancel**.

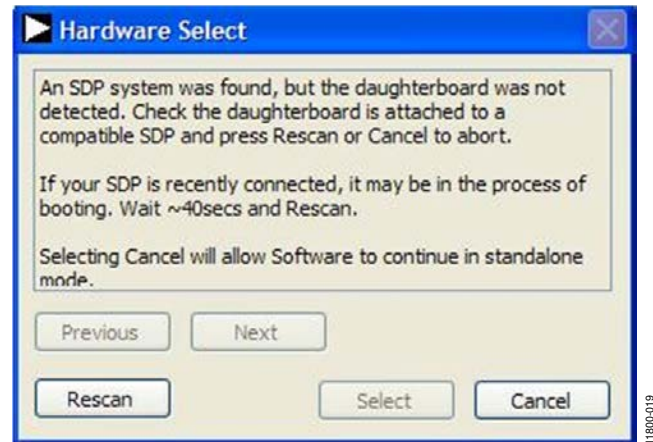

Figure 19. No Hardware Connected Pop-Up Window Error

3. The software alerts the user that no hardware is connected and that the software is going to continue in standalone mode.

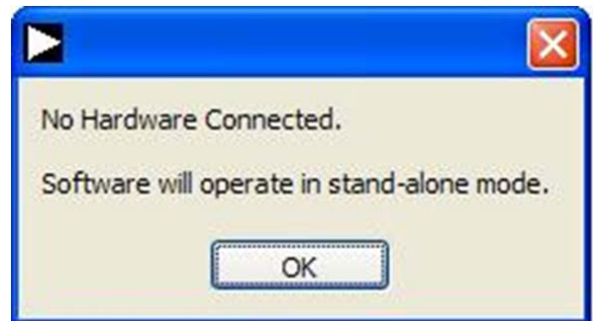

Figure 20. Software Indicates Operating in Standalone Mode

4. You can then load example files or previously saved files and analyze data. The main window of the software appears (see Figure 21), showing the evaluation board connected as the part number from the saved data file.
5. If you decide to connect hardware at this point, you must close the software and relaunch it to allow it to search for the board again.

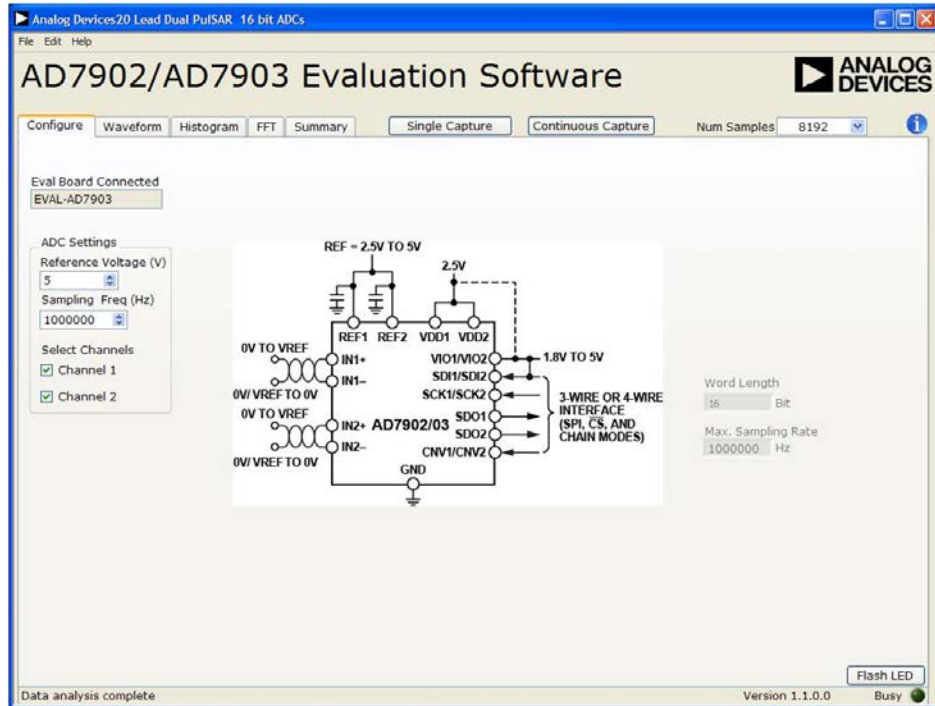

Figure 21. Main Window

OVERVIEW OF THE MAIN WINDOW

The main window of the software is shown in Figure 21 and has the features described in this section.

File Menu

The **File** menu offers the choice to

- **Load data:** load previously captured data.
- **Save Data as .tsv:** save captured data in .tsv format for future analysis.
- **Save Picture:** save the current screen capture.
- **Print:** print the main window to the default printer.
- **Exit:** close the application.

Eval Board Connected Box

The **Eval Board Connected** box displays the evaluation board connected to the USB port—either [EVAL-AD7902SDZ](#) or [EVAL-AD7903SDZ](#).

When an evaluation board is not connected to the USB port, the software can be operated in standalone mode for data analysis, and the part information notes the part number from the saved data file.

ADC Settings Area

The **ADC Settings** section allows changing the sampling frequency and the reference voltage value, as well as selecting Channel 1 or Channel 2.

Reference Voltage (V) Box

By default, the external reference voltage is 5 V ([ADR435](#) on-board reference). The minimum/maximum voltage calculations are based on this reference voltage. If you change the reference voltage, you must change this input accordingly.

Sampling Freq (Hz) Box

The default sampling frequency (10000000 Hz) in the **Sampling Freq (Hz)** box matches the maximum sample rate of the ADC connected to the board. Although you can adjust the sampling frequency, there are limitations in terms of the sample frequencies that can be entered related to the SCLK frequency applied. The

sample frequency must be an integer divider of the SCLK frequency. If an unusable sample frequency is input, the software automatically adjusts the sample frequency accordingly. Units can be entered as, for example, 10k for 10,000 Hz. The software automatically adjusts the sample frequency according to the ability of the ADC connected to the board. For example, if you enter a value that is beyond the ability of the device, the software indicates this and reverts to the maximum sample frequency.

Select Channels Checkboxes

Select either **Channel 1** or **Channel 2** or both to read the data from a single ADC or both ADCs simultaneously.

Tabs Area

There are five tabs available in the tabs area of the main window: **Configure**, **Waveform**, **Histogram**, **FFT**, and **Summary**. These tabs display the data in different formats. Navigation tools are provided within each tab to allow you to control the cursor, zooming, and panning (see Figure 22) within the graphs displayed.

Each tab is described in more detail in the Generating a Waveform Analysis Report; Generating a Histogram of the ADC Code Distribution; Generating a Fast Fourier Transform of AC Characteristics; and Generating a Summary of the Waveform, Histogram, and Fast Fourier Transform sections.

Single Capture Button

Clicking **Single Capture** performs a single capture from the ADC.

Continuous Capture Button

Clicking **Continuous Capture** performs a continuous capture from the ADC.

Num Samples Box

The **Num Samples** box allows you to select the number of samples to analyze.

Exit Button

Clicking the **Exit** button (in the upper right corner of the window) closes the software. Alternatively, you can select **Exit** from the **File** menu.

GENERATING A WAVEFORM ANALYSIS REPORT

Figure 22 illustrates the **Waveform** tab for a 10 kHz sine wave input signal when the on-board 5 V external reference is used.

The **Waveform Analysis** area (located toward the bottom of the window) reports the amplitudes recorded from the captured signal and the frequency of the signal tone. Select the **Channel 1** tab or **Channel 2** tab in the **Waveform Analysis** area to view the corresponding waveform.

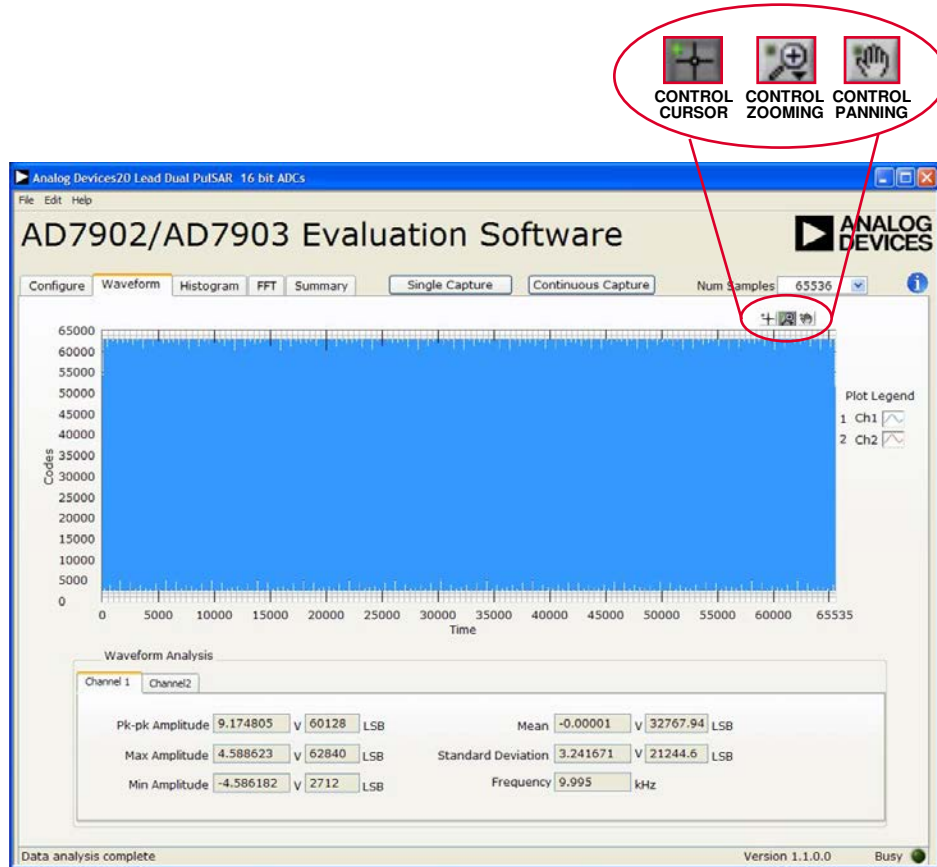

Figure 22. Waveform Tab

GENERATING A HISTOGRAM OF THE ADC CODE DISTRIBUTION

The **Histogram** tab can be used to perform ac testing or, more commonly, dc testing. This tab shows the ADC code distribution of the input and computes the mean and standard deviation, which are displayed as **DC Offset/Mean** and **Transition Noise**, respectively, in the **Histogram Analysis** area (located toward the bottom of the window).

Figure 23 shows the histogram with ac input for a 1 kHz sine wave applied to the ADC input and the resulting calculations.

AC Input

To perform a histogram test of ac input,

1. Apply a differential sinusoidal signal with low distortion (better than 100 dB) to the evaluation board at the J6/J7 or J10/J15 input SMA connector pair.
2. Click the **Histogram** tab from the main window.
3. Click **Single Capture** or **Continuous Capture**.

Raw data is then captured and passed to the PC for statistical computations, and various measured values are displayed in the **Histogram Analysis** area.

DC Input

A histogram test of dc input can be performed with or without an external source because the evaluation board has a buffered $V_{REF}/2$ source at the ADC input.

To perform a histogram test of dc input,

1. If an external source is being used, apply a differential sinusoidal signal with low distortion (better than 100 dB) to the evaluation board at the J6/J7 or J10/J15 input SMA connector pair. It may be required to filter the signal to ensure that the dc source is noise-compatible with the ADC.
2. Click the **Histogram** tab from the main window.
3. Click **Single Capture** or **Continuous Capture**.

Raw data is then captured and passed to the PC for statistical computations, and various measured values are displayed in the **Histogram Analysis** area.

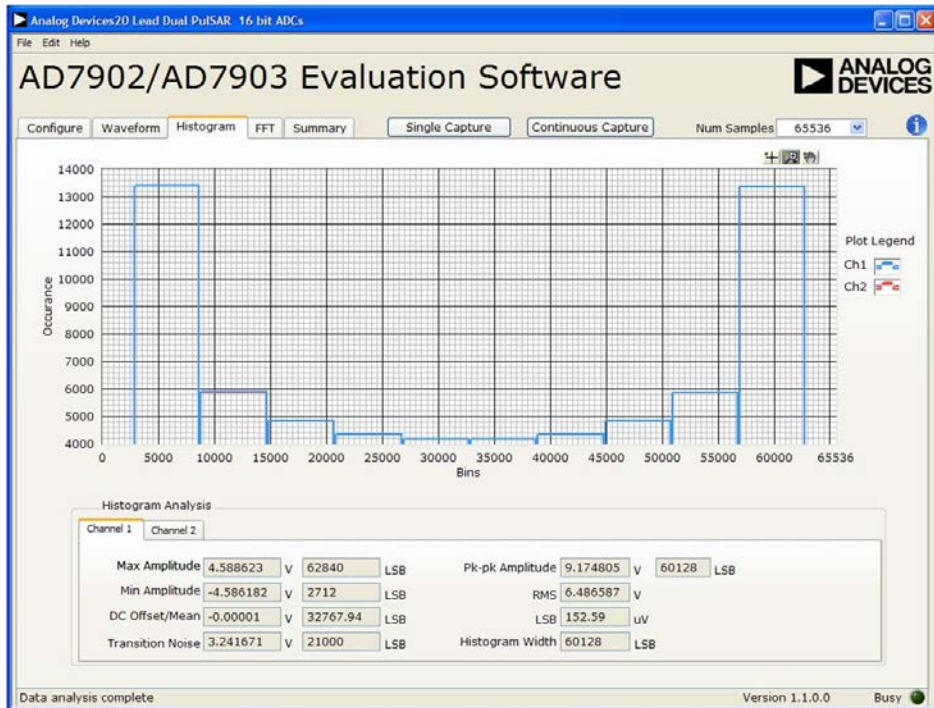

Figure 23. Histogram Tab

GENERATING A FAST FOURIER TRANSFORM OF AC CHARACTERISTICS

Figure 24 shows the FFT tab. This feature tests the traditional ac characteristics of the converter and displays a fast Fourier transform (FFT) of the results.

To perform an ac FFT test,

1. Apply a differential sinusoidal signal with low distortion (better than 100 dB) to the evaluation board at the J6/J7 or J10/J15 input SMA connector pair. To attain the requisite low distortion, which is necessary to allow true evaluation of the part, one option is to
 - a. Filter the input signal from the ac source. A band-pass filter can be used; its center frequency must match the test frequency of interest.
 - b. If a low frequency band-pass filter is used when the full-scale input range is more than a few volts peak-to-peak, use the on-board amplifiers to amplify the signal, thus preventing the filter from distorting the input signal.

2. Click the **FFT** tab from the main window.
3. Click **Sample**.

As in the histogram test, raw data is then captured and passed to the PC, which performs the FFT and displays the resulting SNR, SINAD, THD, and SFDR.

The **FFT Analysis** area displays the results of the captured data.

- The area labeled 1 in Figure 24 shows the spectrum information.
- The area labeled 2 in Figure 24 displays the fundamental frequency and amplitude. You can also click **Show Harmonic Content** to view information about the second to fifth harmonics.
- The area labeled 3 in Figure 24 displays the performance data, including the SNR, dynamic range, THD, SINAD, and noise performance.

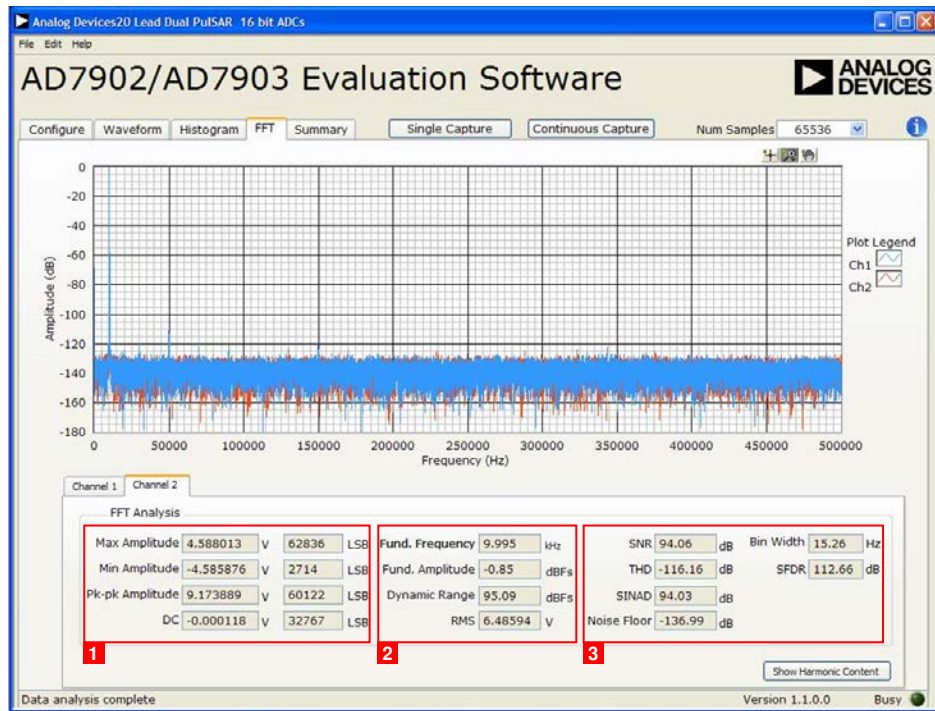

Figure 24. FFT Tab

GENERATING A SUMMARY OF THE WAVEFORM, HISTOGRAM, AND FAST FOURIER TRANSFORM

Figure 25 shows the **Summary** tab. The **Summary** tab captures all the display information and provides it in one panel with a synopsis of the information, including key performance parameters such as SNR and THD.

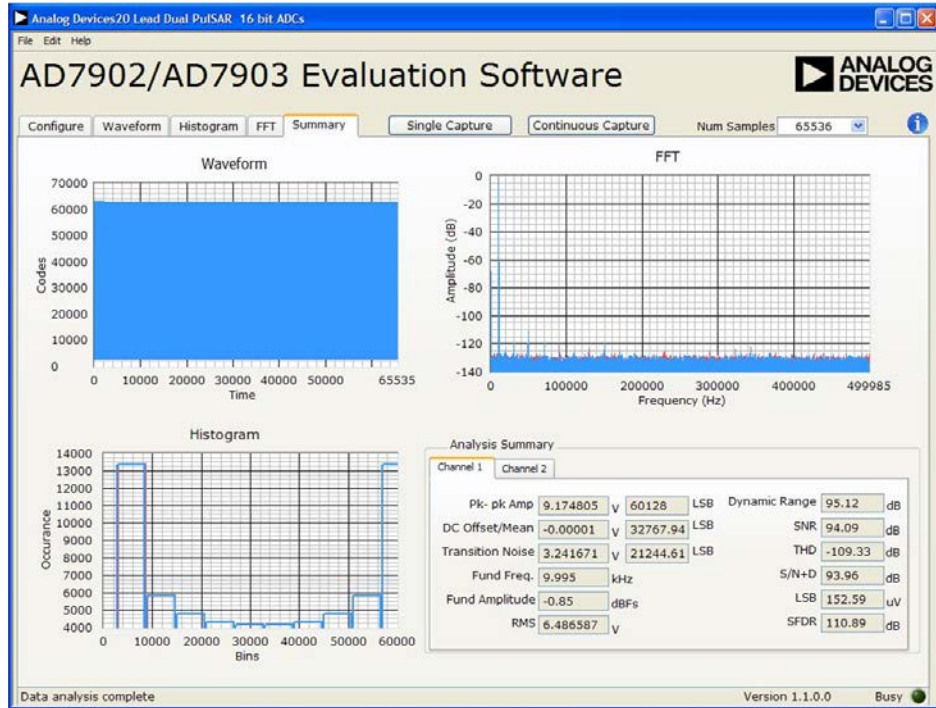

Figure 25. Summary Tab

EVALUATION BOARD SCHEMATICS AND ARTWORK

EVAL-AD7903SDZ SCHEMATICS

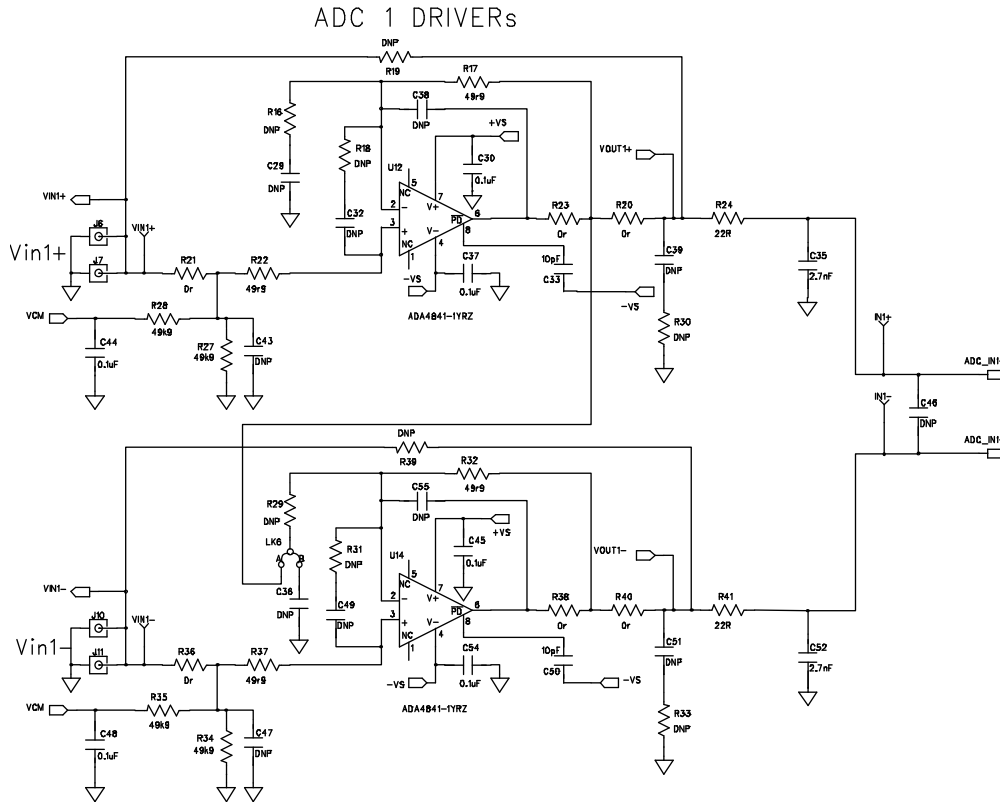

Figure 26. Schematic, Page 1

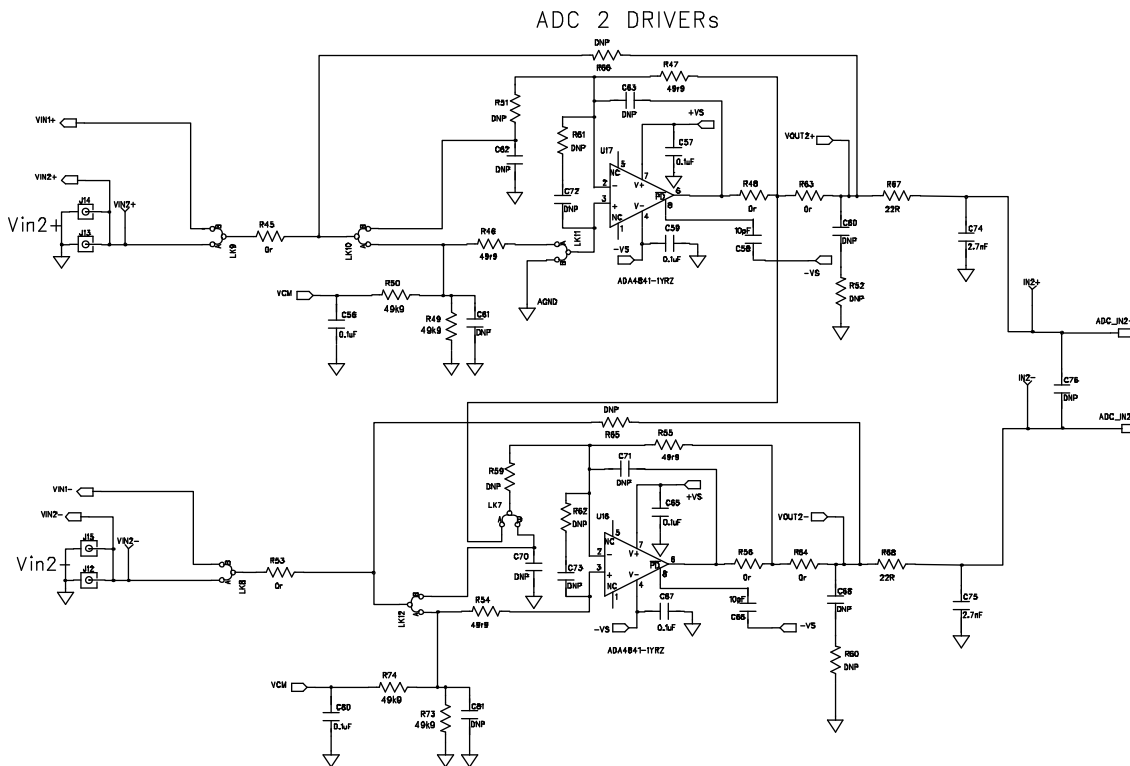

Figure 27. Schematic, Page 2

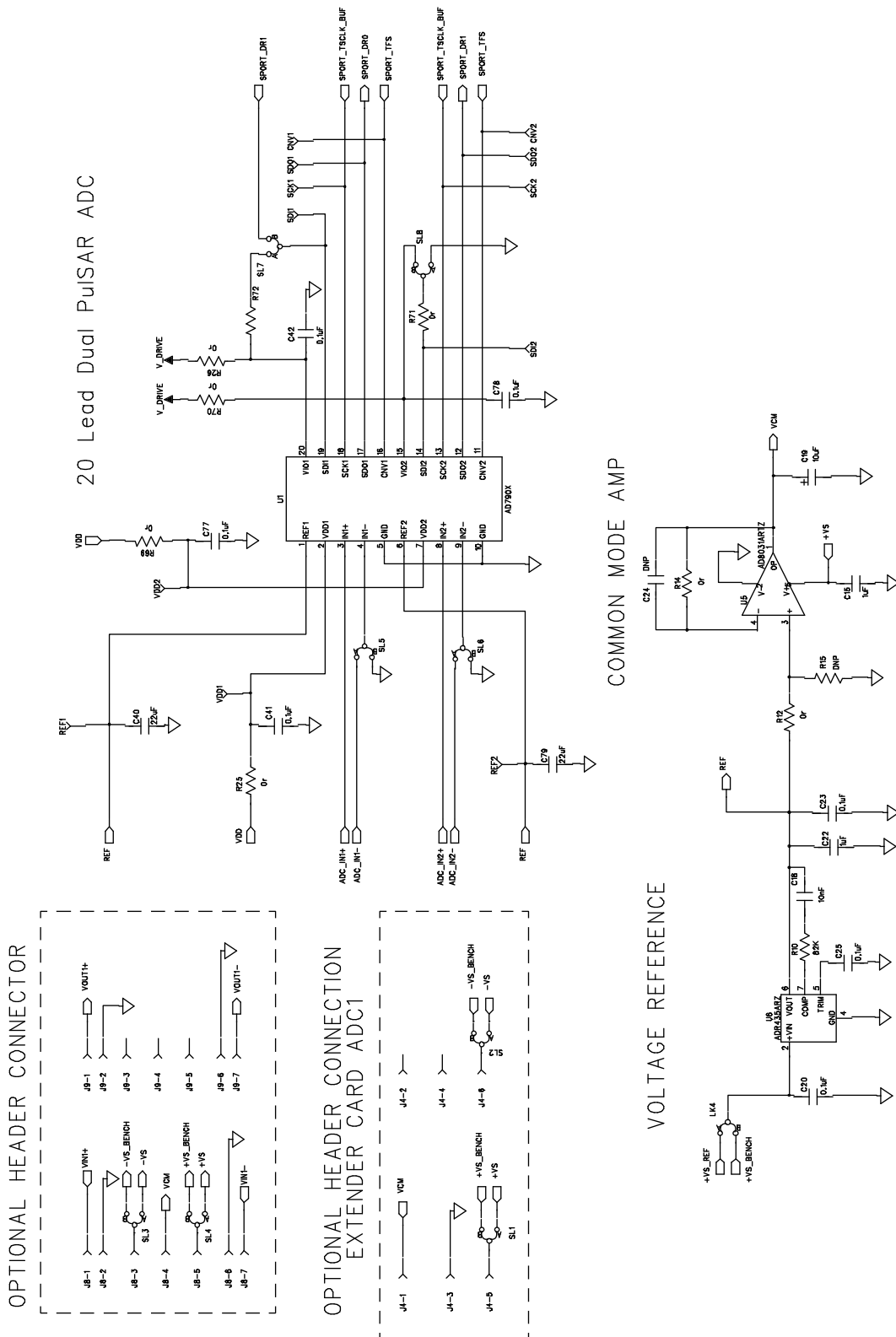

Figure 28. Schematic, Page 3

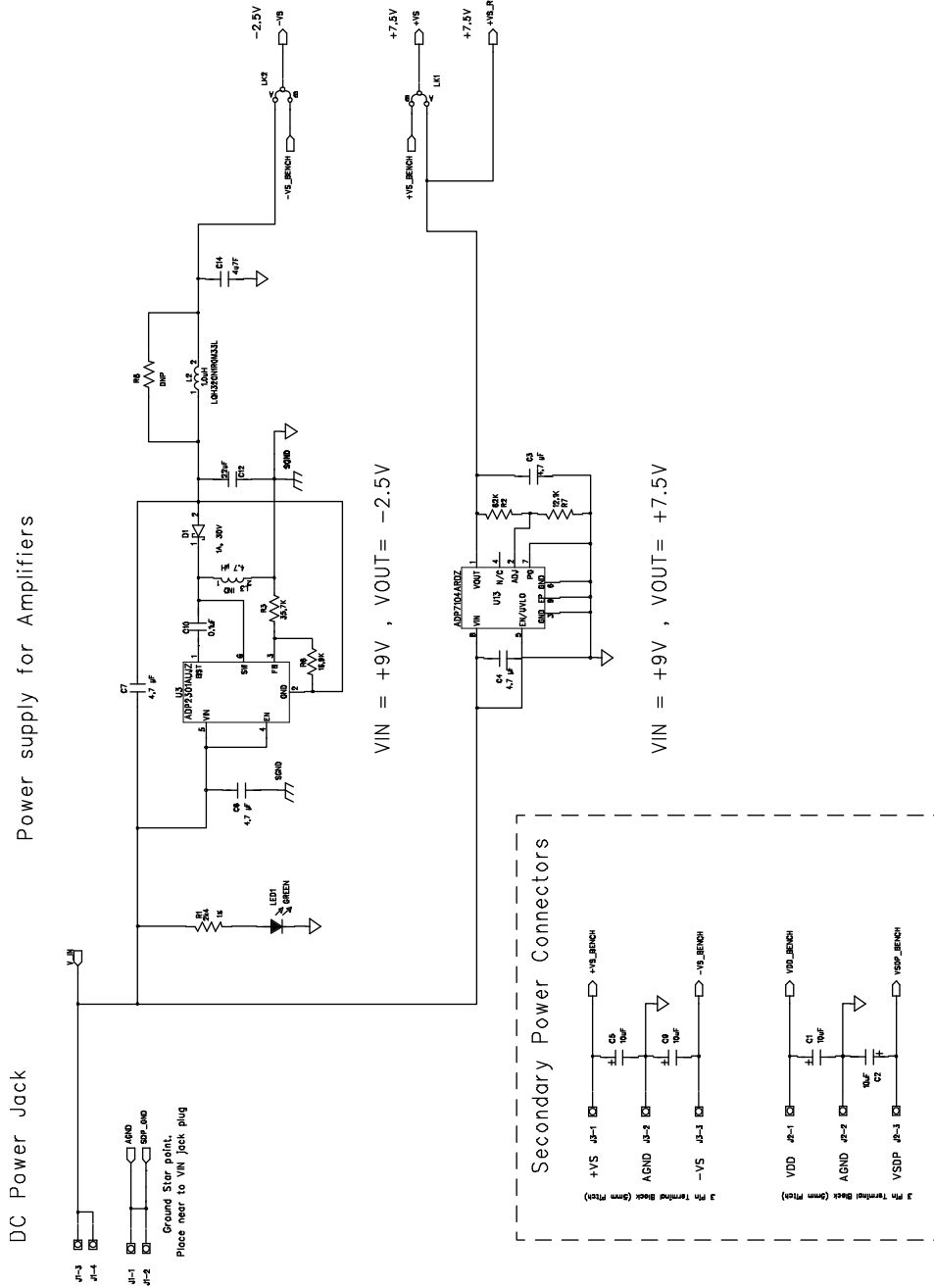

Figure 29. Schematic, Page 4

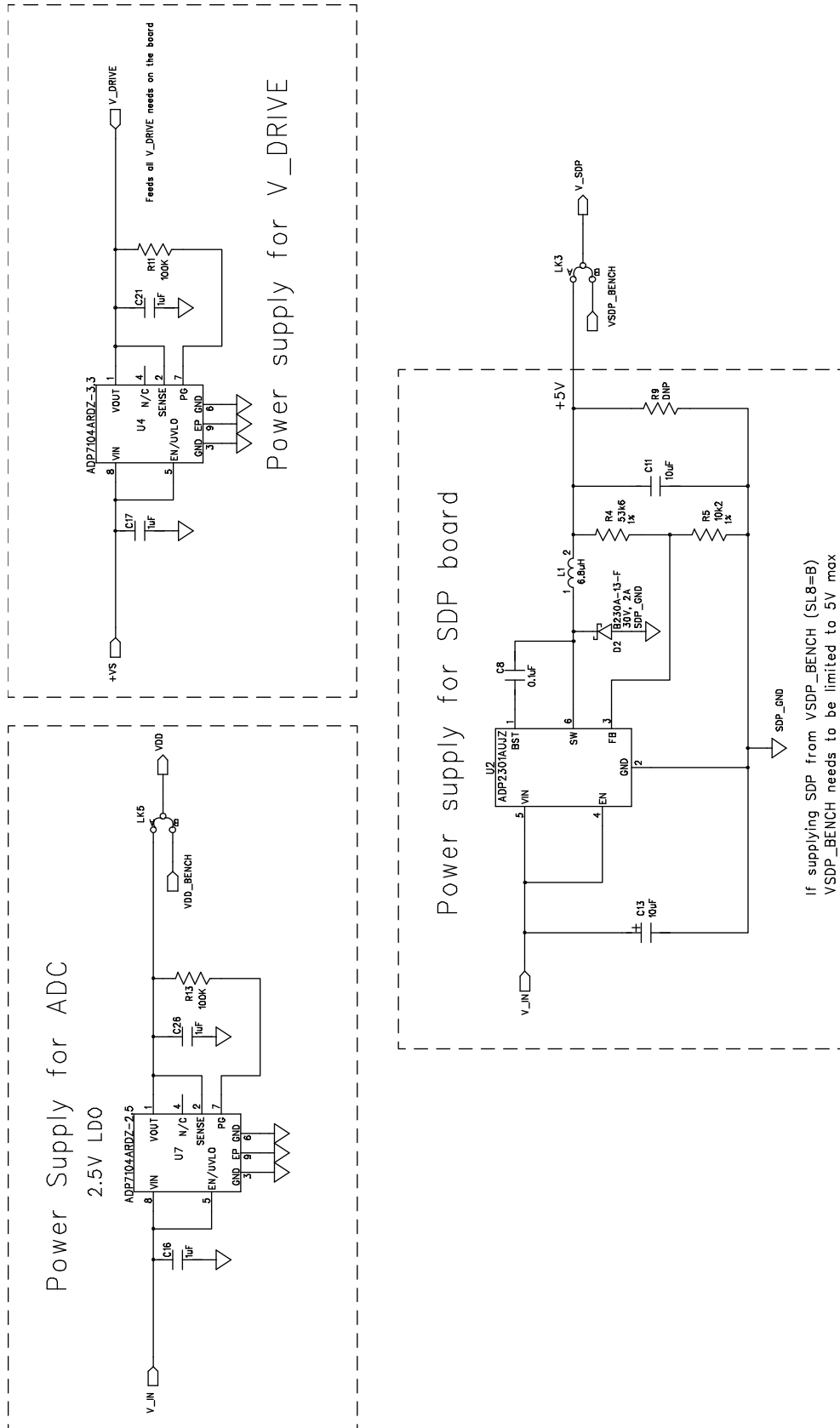

Figure 30. Schematic, Page 5

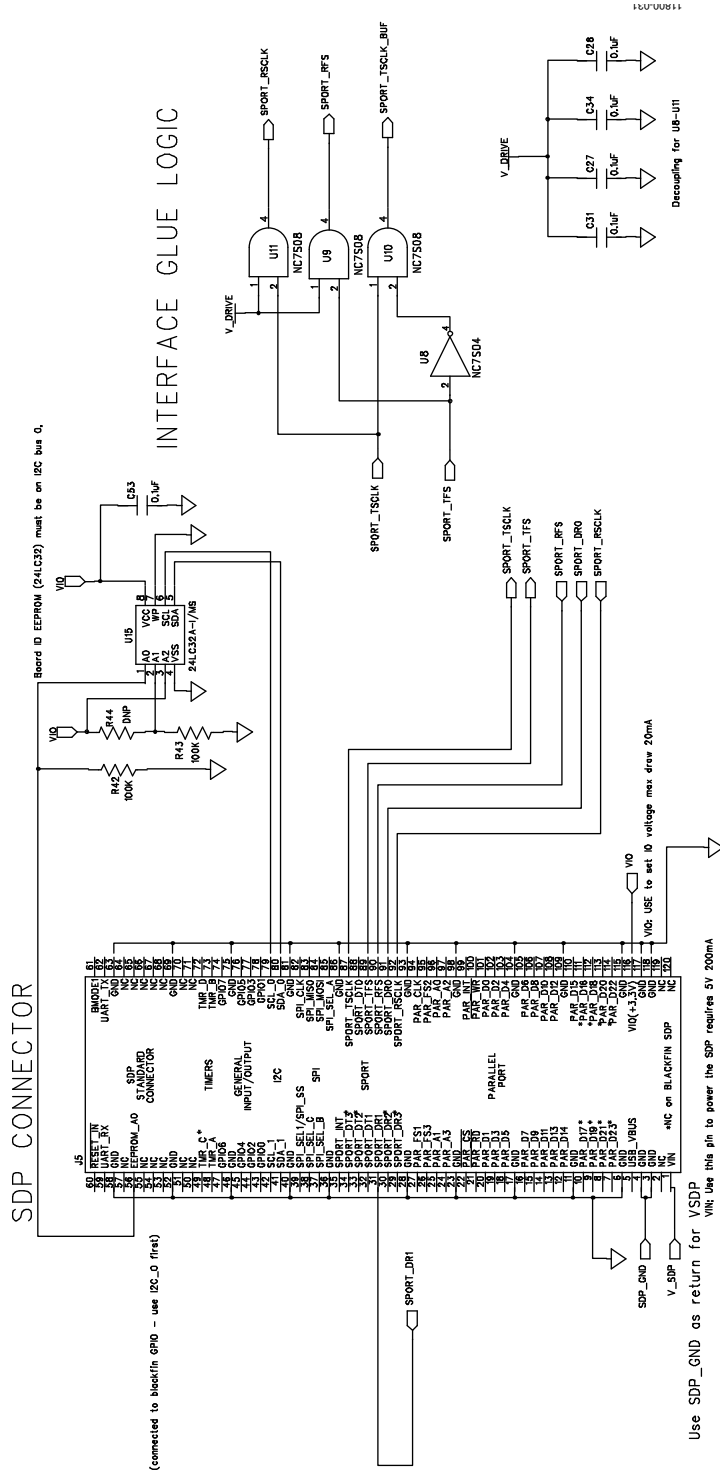

Figure 31. Schematic, Page 6

