



Chipsmall Limited consists of a professional team with an average of over 10 year of expertise in the distribution of electronic components. Based in Hongkong, we have already established firm and mutual-benefit business relationships with customers from,Europe,America and south Asia,supplying obsolete and hard-to-find components to meet their specific needs.

With the principle of “Quality Parts,Customers Priority,Honest Operation,and Considerate Service”,our business mainly focus on the distribution of electronic components. Line cards we deal with include Microchip,ALPS,ROHM,Xilinx,Pulse,ON,Everlight and Freescale. Main products comprise IC,Modules,Potentiometer,IC Socket,Relay,Connector.Our parts cover such applications as commercial,industrial, and automotives areas.

We are looking forward to setting up business relationship with you and hope to provide you with the best service and solution. Let us make a better world for our industry!



Contact us

Tel: +86-755-8981 8866 Fax: +86-755-8427 6832

Email & Skype: info@chipsmall.com Web: www.chipsmall.com

Address: A1208, Overseas Decoration Building, #122 Zhenhua RD., Futian, Shenzhen, China



FEATURES

- Fast throughput rate: 200 kSPS**
- Specified for AV_{DD} of 2.7 V to 5.25 V**
- Low power**
 - 3.6 mW max at 200 kSPS with 3 V supply**
 - 7.5 mW max at 200 kSPS with 5 V supply**
- 4 (single-ended) inputs with sequencer**
- Wide input bandwidth**
 - 70 dB Min SNR at 50 kHz input frequency**
- Flexible power/serial clock speed management**
- No pipeline delays**
- High speed serial interface SPI[®]-/QSPI[™]-/
MICROWIRE[™]-/DSP-compatible**
- Shutdown mode: 0.5 μ A max**
- 16-lead TSSOP package**
- Qualified for automotive applications**

GENERAL DESCRIPTION

The AD7923 is a 12-bit, high speed, low power, 4-channel, successive approximation (SAR) ADC. It operates from a single 2.7 V to 5.25 V power supply and features throughput rates up to 200 kSPS. It contains a low noise, wide bandwidth track-and-hold amplifier that can handle input frequencies in excess of 8 MHz.

The conversion process and data acquisition are controlled by \overline{CS} and the serial clock, allowing the device to easily interface with microprocessors or DSPs. The input signal is sampled on the falling edge of \overline{CS} ; the conversion is also initiated at this point.

The AD7923 uses advanced design techniques to achieve very low power dissipation at maximum throughput rates. At maximum throughput rates, it consumes 1.2 mA maximum with 3 V supplies and 1.5 mA maximum with 5 V supplies.

Through the configuration of the control register, the analog input range can be selected as 0 V to REF_{IN} or 0 V to $2 \times REF_{IN}$, with either straight binary or twos complement output coding. The AD7923 features four single-ended analog inputs with a channel sequencer to allow a preprogrammed selection of channels to be converted sequentially.

The conversion time for the AD7923 is determined by the serial clock, SCLK, frequency, since this is used as the master clock to control the conversion. The conversion time can be as short as 800 ns with a 20 MHz SCLK.

FUNCTIONAL BLOCK DIAGRAM

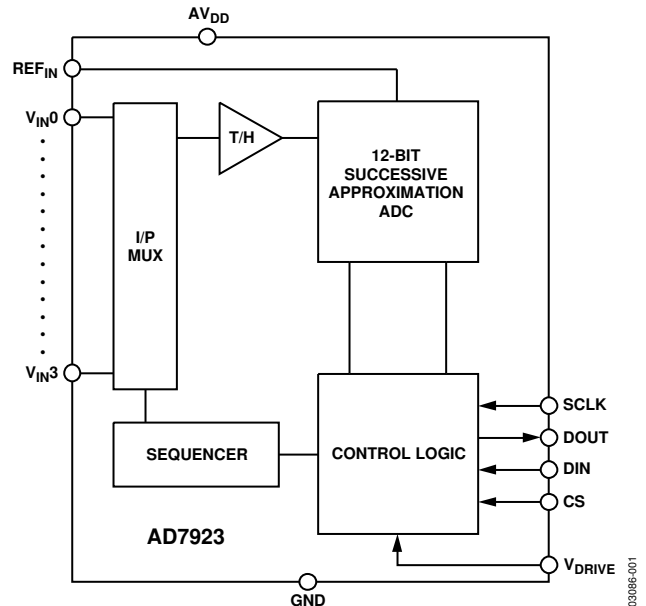

Figure 1.

PRODUCT HIGHLIGHTS

1. **High Throughput with Low Power Consumption.**
The AD7923 offers up to 200 kSPS throughput rates. At the maximum throughput rate with 3 V supplies, the AD7923 dissipates just 3.6 mW of power.
2. **Four Single-Ended Inputs with a Channel Sequencer.**
3. **Single-Supply Operation with V_{DRIVE} Function.**
The V_{DRIVE} function allows the serial interface to connect directly to either 3 V or 5 V processor systems independent of AV_{DD} .
4. **Flexible Power/Serial Clock Speed Management.**
The conversion rate is determined by the serial clock, allowing the conversion time to be reduced through the serial clock speed increase. The part also features various shutdown modes to maximize power efficiency at lower throughput rates. Current consumption is 0.5 μ A maximum when in full shutdown.
5. **No Pipeline Delay.**
The part features a SAR ADC with accurate control of the sampling instant via a \overline{CS} input and once off conversion control.

Rev. D

Document Feedback

Information furnished by Analog Devices is believed to be accurate and reliable. However, no responsibility is assumed by Analog Devices for its use, nor for any infringements of patents or other rights of third parties that may result from its use. Specifications subject to change without notice. No license is granted by implication or otherwise under any patent or patent rights of Analog Devices. Trademarks and registered trademarks are the property of their respective owners.

AD7923* PRODUCT PAGE QUICK LINKS

Last Content Update: 02/23/2017

COMPARABLE PARTS

View a parametric search of comparable parts.

EVALUATION KITS

- AD7923 Evaluation kit

DOCUMENTATION

Application Notes

- AN-742: Frequency Domain Response of Switched-Capacitor ADCs
- AN-931: Understanding PulsAR ADC Support Circuitry

Data Sheet

- AD7923-DSCC: Military Data Sheet
- AD7923-EP: Enhanced Product Data Sheet
- AD7923: 4-Channel, 200 kSPS, 12-Bit ADC with Sequencer in 16-Lead TSSOP Data Sheet

Product Highlight

- 8- to 18-Bit SAR ADCs ... From the Leader in High Performance Analog

Technical Books

- The Data Conversion Handbook, 2005

REFERENCE MATERIALS

Product Selection Guide

- SAR ADC & Driver Quick-Match Guide

Technical Articles

- MS-1779: Nine Often Overlooked ADC Specifications
- MS-2210: Designing Power Supplies for High Speed ADC

Tutorials

- MT-001: Taking the Mystery out of the Infamous Formula, "SNR=6.02N + 1.76dB", and Why You Should Care
- MT-002: What the Nyquist Criterion Means to Your Sampled Data System Design
- MT-031: Grounding Data Converters and Solving the Mystery of "AGND" and "DGND"

DESIGN RESOURCES

- AD7923 Material Declaration
- PCN-PDN Information
- Quality And Reliability
- Symbols and Footprints

DISCUSSIONS

View all AD7923 EngineerZone Discussions.

SAMPLE AND BUY

Visit the product page to see pricing options.

TECHNICAL SUPPORT

Submit a technical question or find your regional support number.

DOCUMENT FEEDBACK

Submit feedback for this data sheet.

TABLE OF CONTENTS

Specifications.....	3	ADC Transfer Function.....	15
Timing Specifications.....	5	Typical Connection Diagram	16
Absolute Maximum Ratings.....	6	Modes of Operation	17
ESD Caution.....	6	Powering Up the AD7923	18
Pin Configuration and Function Description	7	Power vs. Throughput Rate.....	19
Typical Performance Characteristics	8	Serial Interface	20
Terminology	10	Microprocessor Interfacing.....	21
Control Register Descriptions	12	Application Hints	23
Sequencer Operation	13	Grounding and Layout	23
Theory of Operation	14	Outline Dimensions	24
Circuit Information.....	14	Ordering Guide	24
Converter Operation.....	14	Automotive Products.....	24

REVISION HISTORY

6/13—Rev. C to Rev. D

Deleted Evaluating the AD7923 Performance Section.....	23
Changes to Ordering Guide	24

5/11—Rev. B to Rev. C

Changes to Features Section.....	1
Updated Outline Dimensions	24
Changes to Ordering Guide	24
Added to Automotive Products Section.....	24

12/08—Rev. A to Rev. B

Changes to ESD Parameter, Table 3	6
Changes to Ordering Guide	24

8/05—Rev. 0 to Rev. A

Update Format	Universal
Change to Table 1	3
Change to Table 3	6
Change to Reference Section.....	16
Changes to Ordering Guide	24

11/02—Revision 0: Initial Version

SPECIFICATIONS

$V_{DD} = V_{DRIVE} = 2.7\text{ V to }5.25\text{ V}$, $REF_{IN} = 2.5\text{ V}$, $f_{SCLK} = 20\text{ MHz}$, $T_A = T_{MIN}$ to T_{MAX} , unless otherwise noted.

Table 1.

Parameter	B Version ¹	Unit	Test Conditions/Comments
DYNAMIC PERFORMANCE			
Signal-to-(Noise + Distortion) (SINAD) ²	70	dB min	$f_{IN} = 50\text{ kHz sine wave}$, $f_{SCLK} = 20\text{ MHz}$ @ 5 V, $-40^{\circ}\text{C to }+85^{\circ}\text{C}$
	69	dB min	@ 5 V, $85^{\circ}\text{C to }125^{\circ}\text{C}$, typ 70 dB
	69	dB min	@ 3 V typ 70 dB, $-40^{\circ}\text{C to }+125^{\circ}\text{C}$
Signal-to-Noise (SNR) ²	70	dB min	
Total Harmonic Distortion (THD) ²	-77	dB max	@ 5 V typ, -84 dB
	-73	dB max	@ 3 V typ, -77 dB
Peak Harmonic or Spurious Noise (SFDR) ²	-78	dB max	@ 5 V typ, -86 dB
	-76	dB max	@ 3 V typ, -80 dB
Intermodulation Distortion (IMD) ²			$f_A = 40.1\text{ kHz}$, $f_B = 41.5\text{ kHz}$
Second Order Terms	-90	dB typ	
Third Order Terms	-90	dB typ	
Aperture Delay	10	ns typ	
Aperture Jitter	50	ps typ	
Channel-to-Channel Isolation	-85	dB typ	$f_{IN} = 400\text{ kHz}$
Full Power Bandwidth	8.2	MHz typ	@ 3 dB
	1.6	MHz typ	@ 0.1 dB
DC ACCURACY²			
Resolution	12	Bits	
Integral Nonlinearity	± 1	LSB max	
Differential Nonlinearity	$-0.9/+1.5$	LSB max	Guaranteed no missed codes to 12 bits
0 V to REF_{IN} Input Range			Straight binary output coding
Offset Error	± 8	LSB max	Typ $\pm 0.5\text{ LSB}$
Offset Error Match	± 0.5	LSB max	
Gain Error	± 1.5	LSB max	
Gain Error Match	± 0.5	LSB max	
0 V to $2 \times REF_{IN}$ Input Range			$-REF_{IN}$ to $+REF_{IN}$ biased about REF_{IN} with twos complement output coding
Positive Gain Error	± 1.5	LSB max	
Positive Gain Error Match	± 0.5	LSB max	
Zero-Code Error	± 8	LSB max	Typ $\pm 0.8\text{ LSB}$
Zero-Code Error Match	± 0.5	LSB max	
Negative Gain Error	± 1	LSB max	
Negative Gain Error Match	± 0.5	LSB max	
ANALOG INPUT			
Input Voltage Range	0 to REF_{IN}	V	Range bit set to 1
	0 to $2 \times REF_{IN}$	V	Range bit set to 0, $V_{DD} = 4.75\text{ V to }5.25\text{ V}$
DC Leakage Current	± 1	$\mu\text{A max}$	
Input Capacitance	20	pF typ	
REFERENCE INPUT			
REF_{IN} Input Voltage	2.5	V	$\pm 1\%$ specified performance
DC Leakage Current	± 1	$\mu\text{A max}$	
REF_{IN} Input Impedance	36	k Ω typ	$f_{SAMPLE} = 200\text{ kSPS}$
LOGIC INPUTS			
Input High Voltage, V_{INH}	$0.7 \times V_{DRIVE}$	V min	
Input Low Voltage, V_{INL}	$0.3 \times V_{DRIVE}$	V max	
Input Current, I_{IN}	± 1	$\mu\text{A max}$	Typ 10 nA, $V_{IN} = 0\text{ V or }V_{DRIVE}$
Input Capacitance, C_{IN}^3	10	pF max	

Parameter	B Version ¹	Unit	Test Conditions/Comments
LOGIC OUTPUTS			
Output High Voltage, V_{OH}	$V_{DRIVE} - 0.2$	V min	$I_{SOURCE} = 200 \mu A$, $AV_{DD} = 2.7 V$ to $5.25 V$ $I_{SINK} = 200 \mu A$
Output Low Voltage, V_{OL}	0.4	V max	
Floating-State Leakage Current	± 1	μA max	Coding bit set to 0 Coding bit set to 1
Floating-State Output Capacitance ³	10	pF max	
Output Coding	Twos Complement Straight (Natural) Binary		
CONVERSION RATE			
Conversion Time			16 SCLK cycles with SCLK at 20 MHz Sinewave input Full-scale step Input See Serial Interface section
Track-and-Hold Acquisition Time	800	ns max	
	300	ns max	
	300	ns max	
Throughput Rate	200	kSPS max	
POWER REQUIREMENTS			
AV_{DD}	2.7/5.25	V min/max	Digital I/Ps = 0 V or V_{DRIVE} $AV_{DD} = 4.75 V$ to $5.25 V$, $f_{SCLK} = 20 MHz$ $AV_{DD} = 2.7 V$ to $3.6 V$, $f_{SCLK} = 20 MHz$ $AV_{DD} = 2.7 V$ to $5.25 V$, SCLK on or off $AV_{DD} = 4.75 V$ to $5.25 V$, $f_{SCLK} = 20 MHz$ $AV_{DD} = 2.7 V$ to $3.6 V$, $f_{SCLK} = 20 MHz$ $AV_{DD} = 4.75 V$ to $5.25 V$, $f_{SAMPLE} = 200 kSPS$ $AV_{DD} = 2.7 V$ to $3.6 V$, $f_{SAMPLE} = 200 kSPS$ SCLK on or off (20 nA typ) SCLK on or off (20 nA typ) $AV_{DD} = 5 V$, $f_{SCLK} = 20 MHz$ $AV_{DD} = 3 V$, $f_{SCLK} = 20 MHz$ $AV_{DD} = 5 V$ $AV_{DD} = 3 V$ $AV_{DD} = 5 V$ $AV_{DD} = 3 V$
V_{DRIVE}	2.7/5.25	V min/max	
I_{DD} ⁴			
During Conversion	2.7	mA max	
	2.0	mA max	
Normal Mode (Static)	600	μA typ	
Normal Mode (Operational) $f_{SAMPLE} = 200 kSPS$	1.5	mA max	
	1.2	mA max	
Using Auto Shutdown Mode $f_{SAMPLE} = 200 kSPS$	900	μA typ	
	650	μA typ	
Auto Shutdown (Static)	0.5	μA max	
Full Shutdown Mode	0.5	μA max	
Power Dissipation ⁴			
Normal Mode (Operational) $f_{SAMPLE} = 200 kSPS$	7.5	mW max	
	3.6	mW max	
Auto Shutdown (Static)	2.5	μW max	
	1.5	μW max	
Full Shutdown Mode	2.5	μW max	
	1.5	μW max	

¹ Temperature range: B Version: $-40^{\circ}C$ to $+125^{\circ}C$.

² See Terminology section.

³ Sample tested @ $25^{\circ}C$ to ensure compliance.

⁴ See Power vs. Throughput Rate section.

TIMING SPECIFICATIONS

$AV_{DD} = 2.7\text{ V to }5.25\text{ V}$, $V_{DRIVE} \leq AV_{DD}$, $REF_{IN} = 2.5\text{ V}$, $T_A = T_{MIN}$ to T_{MAX} , unless otherwise noted.¹

Table 2.

Parameter	Limit at T_{MIN} , T_{MAX}			Description
	$AV_{DD} = 3\text{ V}$	$AV_{DD} = 5\text{ V}$	Unit	
f_{SCLK}^2	10	10	kHz min	
	20	20	MHz max	
$t_{CONVERT}$	$16 \times t_{SCLK}$	$16 \times t_{SCLK}$		
t_{QUIET}	50	50	ns min	Minimum quiet time required between \overline{CS} rising edge and start of next conversion
t_2	10	10	ns min	\overline{CS} to SCLK set-up time
t_3^3	35	30	ns max	Delay from \overline{CS} until DOUT three-state disabled
t_4^3	40	40	ns max	Data access time after SCLK falling edge
t_5	$0.4 \times t_{SCLK}$	$0.4 \times t_{SCLK}$	ns min	SCLK low pulse width
t_6	$0.4 \times t_{SCLK}$	$0.4 \times t_{SCLK}$	ns min	SCLK high pulse width
t_7	10	10	ns min	SCLK to DOUT valid hold time
t_8^4	15/45	15/35	ns min/max	SCLK falling edge to DOUT high impedance
t_9	10	10	ns min	DIN set-up time prior to SCLK falling edge
t_{10}	5	5	ns min	DIN hold time after SCLK falling edge
t_{11}	20	20	ns min	Sixteenth SCLK falling edge to \overline{CS} high
t_{12}	1	1	μs max	Power-Up time from full power-down/auto shutdown mode

¹ Sample tested at 25°C to ensure compliance. All input signals are specified with $t_R = t_F = 5\text{ ns}$ (10% to 90% of AV_{DD}) and timed from a voltage level of 1.6 V. See Figure 2. The 3 V operating range spans from 2.7 V to 3.6 V. The 5 V operating range spans from 4.75 V to 5.25 V.

² The mark/space ratio for the SCLK input is 40/60 to 60/40.

³ Measured with the load circuit of Figure 2 and defined as the time required for the output to cross 0.4 V or $0.7 \times V_{DRIVE}$.

⁴ t_8 is derived from the measured time taken by the data outputs to change 0.5 V when loaded with the circuit of Figure 2. The measured number is then extrapolated back to remove the effects of charging or discharging the 50 pF capacitor. This means that the time, quoted in the timing characteristics t_8 , is the true bus relinquish time of the part and is independent of the bus loading.

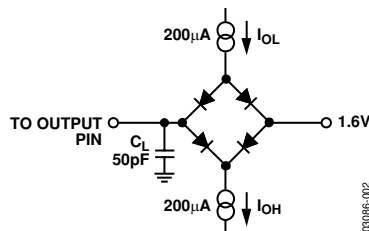

Figure 2. Load Circuit for Digital Output Timing Specification

ABSOLUTE MAXIMUM RATINGS

$T_A = 25^\circ\text{C}$, unless otherwise noted.

Table 3.

Parameter	Rating
AV_{DD} to AGND	-0.3 V to +7 V
V_{DRIVE} to AGND	-0.3 V to $AV_{DD} + 0.3$ V
Analog Input Voltage to AGND	-0.3 V to $AV_{DD} + 0.3$ V
Digital Input Voltage to AGND	-0.3 V to +7 V
Digital Output Voltage to AGND	-0.3 V to $AV_{DD} + 0.3$ V
REF_{IN} to AGND	-0.3 V to $AV_{DD} + 0.3$ V
Input Current to Any Pin Except Supplies ¹	± 10 mA
Operating Temperature Range	
Commercial (B Version)	-40°C to +125°C
Storage Temperature Range	-65°C to +150°C
Junction Temperature	150°C
TSSOP Package, Power Dissipation	450 mW
θ_{JA} Thermal Impedance	150.4°C/W (TSSOP)
θ_{JC} Thermal Impedance	27.6°C/W (TSSOP)
Lead Temperature, Soldering	
Vapor Phase (60 sec)	215°C
Infrared (15 sec)	220°C
Pb-free Temperature, Soldering	
Reflow	260(+0)°C
ESD	1.5 kV

¹ Transient currents of up to 100 mA do not cause SCR latchup.

ESD CAUTION

ESD (electrostatic discharge) sensitive device. Electrostatic charges as high as 4000 V readily accumulate on the human body and test equipment and can discharge without detection. Although this product features proprietary ESD protection circuitry, permanent damage may occur on devices subjected to high energy electrostatic discharges. Therefore, proper ESD precautions are recommended to avoid performance degradation or loss of functionality.



Stresses above those listed under Absolute Maximum Ratings may cause permanent damage to the device. This is a stress rating only and functional operation of the device at these or any other conditions above those indicated in the operational section of this specification is not implied. Exposure to absolute maximum rating conditions for extended periods may affect device reliability.

PIN CONFIGURATION AND FUNCTION DESCRIPTION

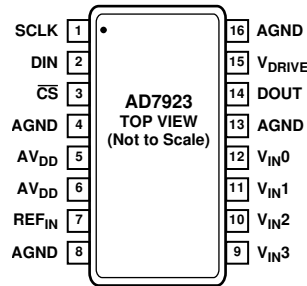

Figure 3. Pin Configuration

Table 4. Pin Function Descriptions

Pin No.	Mnemonic	Function
1	SCLK	Serial Clock. Logic Input. SCLK provides the serial clock for accessing data for the part. This clock input is also used as the clock source for the AD7923 conversion process.
2	DIN	Data In. Logic Input. Data to be written to the control register is provided on this input and is clocked into the register on the falling edge of SCLK (see the Control Register Descriptions section).
3	\overline{CS}	Chip Select. Active low logic input. This input provides the dual function of initiating conversions on the AD7923 and framing the serial data transfer.
4, 8, 13, 16	AGND	Analog Ground. Ground reference point for all analog circuitry on the AD7923. All analog input signals and any external reference signal should be referred to this AGND voltage. All AGND pins should be connected together.
5, 6	AV _{DD}	Analog Power Supply Input. The AV _{DD} range for the AD7923 is from 2.7 V to 5.25 V. For the 0 V to 2 × REF _{IN} range, AV _{DD} should be from 4.75 V to 5.25 V.
7	REF _{IN}	Reference Input for the AD7923. An external reference must be applied to this input. The voltage range for the external reference is 2.5 V ± 1% for specified performance.
12 to 9	V _{IN0} to V _{IN3}	Analog Input 0 through Analog Input 3. Four single-ended analog input channels that are multiplexed into the on-chip track-and-hold. The analog input channel to be converted is selected by using the Address Bits ADD1 and ADD0 of the control register. The address bits in conjunction with the SEQ1 and SEQ0 bits allow the sequencer to be programmed. The input range for all input channels can extend from 0 V to REF _{IN} or from 0 V to 2 × REF _{IN} as selected via the range bit in the control register. Any unused input channels must be connected to AGND to avoid noise pickup.
14	DOUT	Data Out. Logic Output. The conversion result from the AD7923 is provided on this output pin as a serial data stream. The AD7923 serial data stream consists of two leading 0s, and two address bits indicating which channel the conversion result corresponds to, followed by 12 bits of conversion data, MSB first. The output coding can be selected as straight binary or twos complement via the coding bit in the control register. The data bits are clocked out of the AD7923 on the SCLK falling edge.
15	V _{DRIVE}	Logic Power Supply Input. The voltage supplied at this pin determines at which voltage the serial interface operates.

TYPICAL PERFORMANCE CHARACTERISTICS

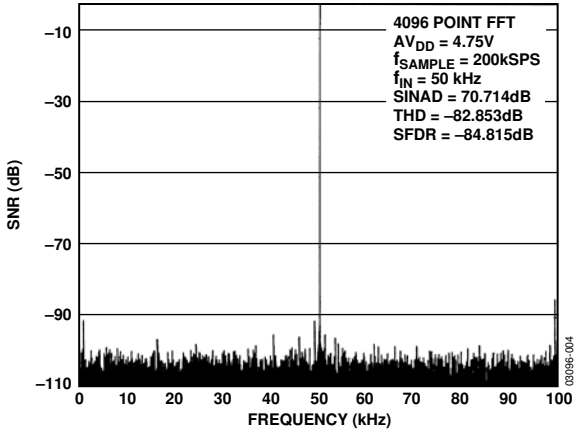

Figure 4. Dynamic Performance at 200 kSPS

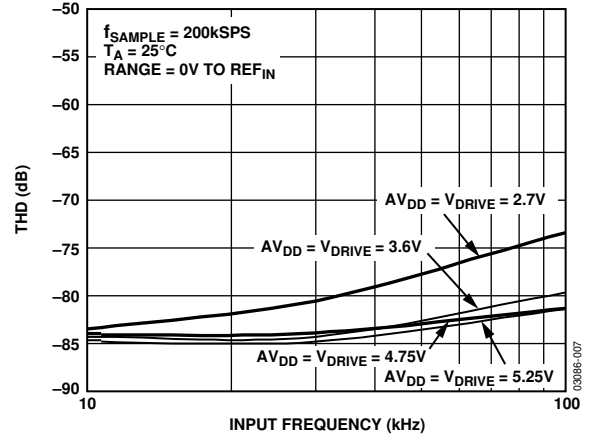

Figure 7. THD vs. Analog Input Frequency for Various Supply Voltages at 200 kSPS

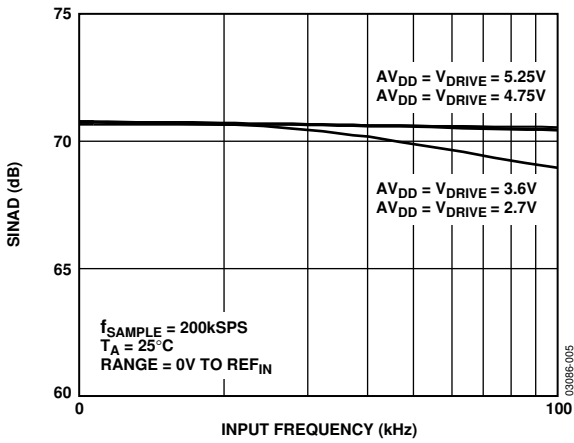

Figure 5. SINAD vs. Analog Input Frequency for Various Supply Voltages at 200 kSPS

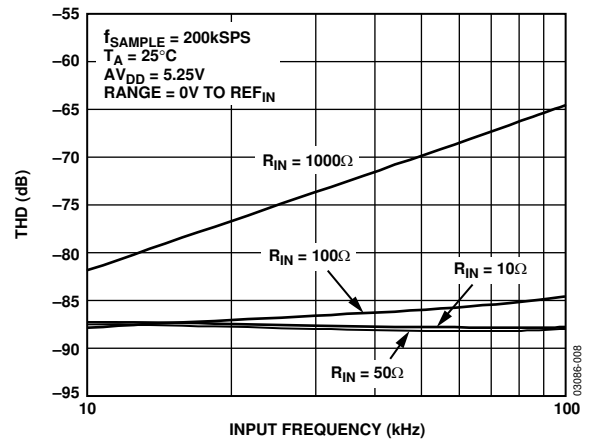

Figure 8. THD vs. Analog Input Frequency for Various Source Impedances

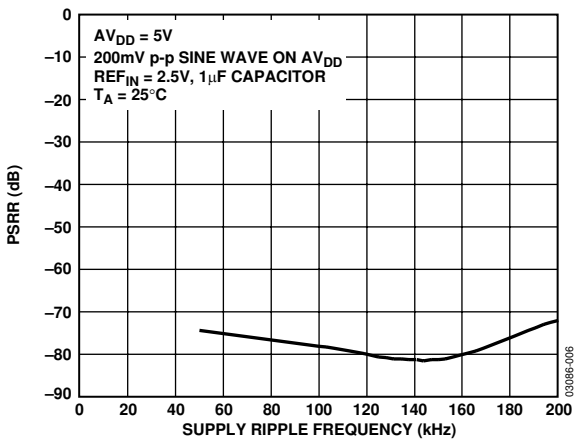

Figure 6. PSRR vs. Supply Ripple Frequency

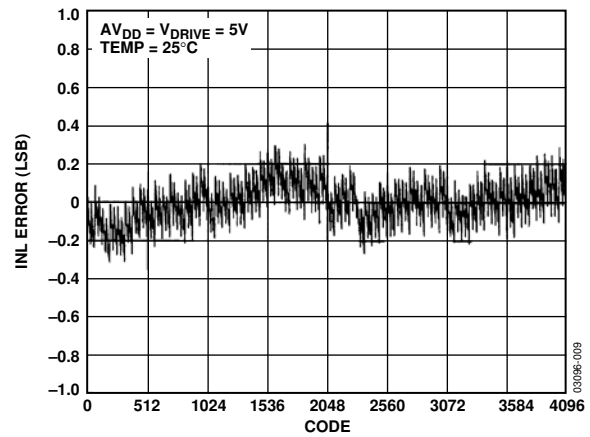

Figure 9. Typical INL

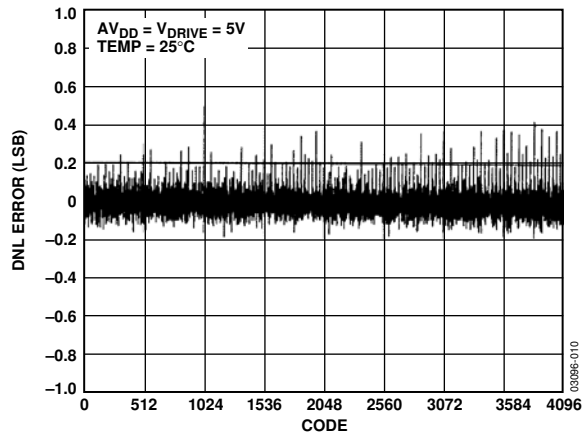

Figure 10. Typical DNL

TERMINOLOGY

Integral Nonlinearity

This is the maximum deviation from a straight line passing through the endpoints of the ADC transfer function. The endpoints of the transfer function are zero scale, a point 1 LSB below the first code transition, and full scale, a point 1 LSB above the last code transition.

Differential Nonlinearity

This is the difference between the measured and the ideal 1 LSB change between any two adjacent codes in the ADC.

Offset Error

This is the deviation of the first code transition (00 ... 000) to (00 ... 001) from the ideal, that is, AGND + 1 LSB.

Offset Error Match

This is the difference in offset error between any two channels.

Gain Error

This is the deviation of the last code transition (111 ... 110) to (111 ... 111) from the ideal (that is, $REF_{IN} - 1$ LSB) after the offset error has been adjusted.

Gain Error Match

This is the difference in gain error between any two channels.

Zero-Code Error

This applies when using the twos complement output coding option, in particular, with the $2 \times REF_{IN}$ input range when $-REF_{IN}$ to $+REF_{IN}$ is biased around the REF_{IN} point. It is defined as the deviation of the midscale transition (all 0s to all 1s) from the ideal V_{IN} voltage, that is, $REF_{IN} - 1$ LSB.

Zero-Code Error Match

This is the difference in zero-code error between any two channels.

Positive Gain Error

This applies when using the twos complement output coding option, in particular, with the $2 \times REF_{IN}$ input range when $-REF_{IN}$ to $+REF_{IN}$ is biased around the REF_{IN} point. It is the deviation of the last code transition (011 ... 110) to (011 ... 111) from the ideal (that is, $+REF_{IN} - 1$ LSB) after the zero-code error has been adjusted.

Positive Gain Error Match

This is the difference in positive gain error between any two channels.

Negative Gain Error

This applies when using the twos complement output coding option, in particular, with the $2 \times REF_{IN}$ input range when $-REF_{IN}$ to $+REF_{IN}$ is biased around the REF_{IN} point. It is the deviation of the first code transition (100 ... 000) to (100 ... 001) from the ideal (that is, $-REF_{IN} + 1$ LSB) after the zero-code error has been adjusted.

Negative Gain Error Match

This is the difference in negative gain error between any two channels.

Channel-to-Channel Isolation

Channel-to-channel isolation is a measure of the level of cross-talk between channels. It is measured by applying a full-scale 400 kHz sine wave signal to all three nonselected input channels and determining how much that signal is attenuated in the selected channel with a 50 kHz signal. The figure is given in the worst-case across all four channels for the AD7923.

Power Supply Rejection (PSR)

Variations in power supply affect the full-scale transition, but not the converter's linearity. Power supply rejection is the maximum change in the full-scale transition point from a change in power supply voltage from the nominal value.

Figure 6 shows the power supply rejection ratio vs. supply ripple frequency for the AD7923 with no decoupling. The power supply rejection ratio is defined as the ratio of the power in the ADC output at full-scale frequency, f , to the power of a 200 mV p-p sine wave applied to the ADC AV_{DD} supply of frequency f_s :

$$PSSR (dB) = 10 \log(P_f/P_{f_s})$$

P_f is equal to the power at frequency f in the ADC output; P_{f_s} is equal to the power at frequency f_s coupled onto the ADC AV_{DD} supply.

Track-and-Hold Acquisition Time

The track-and-hold amplifier returns into track mode at the end of conversion. Track-and-hold acquisition time is the time required for the output of the track-and-hold amplifier to reach its final value, within ± 1 LSB, after the end of conversion.

Signal-to-(Noise + Distortion) (SINAD) Ratio

This is the measured ratio of SINAD at the output of the ADC. The signal is the rms amplitude of the fundamental. Noise is the sum of all nonfundamental signals up to half the sampling frequency ($f_s/2$), excluding dc. The ratio is dependent on the number of quantization levels in the digitization process, the more levels, the smaller the quantization noise. The theoretical SINAD ratio for an ideal N-bit converter with a sine wave input is given by

$$SINAD = (6.02N + 1.76) \text{ dB}$$

Thus for a 12-bit converter, this is 74 dB.

Total Harmonic Distortion (THD)

THD is the ratio of the rms sum of harmonics to the fundamental. For the AD7923, it is defined as

$$THD(\text{dB}) = 20 \log \frac{\sqrt{V_2^2 + V_3^2 + V_4^2 + V_5^2 + V_6^2}}{V_1}$$

where V_1 is the rms amplitude of the fundamental and V_2 , V_3 , V_4 , V_5 , and V_6 are the rms amplitudes of the second through the sixth harmonics.

CONTROL REGISTER DESCRIPTIONS

The control register on the AD7923 is a 12-bit, write-only register. Data is loaded from the DIN pin of the AD7923 on the falling edge of SCLK. The data is transferred on the DIN line at the same time that the conversion result is read from the part. The data transferred on the DIN line corresponds to the

AD7923 configuration for the next conversion. This requires 16 serial clocks for every data transfer. Only the information provided on the first 12 falling clock edges (after \overline{CS} falling edge) is loaded to the control register. MSB denotes the first bit in the data stream. The bit functions are outlined in Table 5.

Table 5. Control Register Bit Functions

MSB											LSB
WRITE	SEQ1	DONTC	DONTC	ADD1	ADD0	PM1	PM0	SEQ0	DONTC	RANGE	CODING

Table 6.

Bit	Name	Description
11	WRITE	The value written to this bit of the control register determines whether the following 11 bits are loaded to the control register. If this bit is a 1, the following 11 bits are written to the control register. If it is a 0, the remaining 11 bits are not loaded to the control register and it remains unchanged.
10	SEQ1	The SEQ1 bit in the control register is used with the SEQ0 bit to control the use of the sequencer function (see Table 9).
7–6	ADD1 ADD0	These two address bits are loaded at the end of the present conversion and select which analog input channel is converted in the next serial transfer, or they can also be used to select the final channel in a consecutive sequence, as described in Table 9. The selected input channel is decoded, as shown in Table 7. The next channel to be converted on is selected by the mux on the 14th SCLK falling edge. Channel address bits corresponding to the conversion result are also output on the DOUT serial data stream prior to the 12 bits of data (see the Serial Interface section).
5, 4	PM1 PM0	Power management bits. These two bits decode the mode of operation of the AD7923, as shown in Table 8.
3	SEQ0	The SEQ0 bit in the control register is used with the SEQ1 bit to control the use of the sequencer function. (see Table 9).
2, 9–8	DONTC	Don't care.
1	RANGE	This bit selects the analog input range to be used on the AD7923. If it is set to 0, the analog input range extends from 0 V to $2 \times \text{REF}_{\text{IN}}$. If it is set to 1, the analog input range extends from 0 V to REF_{IN} (for the next conversion). For the 0 V to $2 \times \text{REF}_{\text{IN}}$ range, $\text{AV}_{\text{DD}} = 4.75 \text{ V}$ to 5.25 V .
0	CODING	This bit selects the type of output coding the AD7923 uses for the conversion result. If this bit is set to 0, the output coding for the part is twos complement. If this bit is set to 1, the output coding from the part is straight binary (for the next conversion).

Table 7. Channel Selection

ADD1	ADD0	Analog Input Channel
0	0	$V_{\text{IN}0}$
0	1	$V_{\text{IN}1}$
1	0	$V_{\text{IN}2}$
1	1	$V_{\text{IN}3}$

Table 8. Power Mode Selection

PM1	PM0	Mode
1	1	Normal operation. In this mode, the AD7923 remains in full power mode, regardless of the status of any of the logic inputs. This mode allows the fastest possible throughput rate from the AD7923.
1	0	Full shutdown. In this mode, the AD7923 is in full shutdown mode with all circuitry on the AD7923 powering down. The AD7923 retains the information in the control register while in full shutdown. The part remains in full shutdown until these bits are changed.
0	1	Auto shutdown. In this mode, the AD7923 automatically enters full shutdown mode at the end of each conversion when the control register is updated. Wake-up time from full shutdown is 1 μ s, and the user should ensure that 1 μ s has elapsed before attempting to perform a valid conversion on the part in this mode.
0	0	Invalid selection. This configuration is not allowed.

SEQUENCER OPERATION

The configuration of the SEQ1 and SEQ0 bits in the control register allows the user to select a particular mode of operation of the sequencer function. Table 9 outlines the three modes of operation of the sequencer.

Table 9. Sequence Selection

SEQ1	SEQ0	Sequence Type
0	X	This configuration means that the sequence function is not used. The analog input channel selected for each individual conversion is determined by the contents of Channel Address Bits ADD1 and ADD0 in each prior write operation. This mode of operation reflects the traditional operation of a multichannel ADC without the sequencer function being used, where each write to the AD7923 selects the next channel for conversion (see Figure 11).
1	0	If the SEQ1 and SEQ0 bits are set in this way, the sequence function is not interrupted upon completion of the write operation. This allows other bits in the control register to be altered between conversions while in a sequence without terminating the cycle.
1	1	This configuration is used in conjunction with Channel Address Bits ADD1 and ADD0 to program continuous conversions on a consecutive sequence of channels from Channel 0 to a selected final channel as determined by the channel address bits in the control register (see Figure 12).

Figure 11 reflects the traditional operation of a multichannel ADC, where each serial transfer selects the next channel for conversion. In this mode of operation the sequencer function is not used.

Figure 12 shows how to program the AD7923 to continuously convert on a sequence of consecutive channels from Channel 0 to a selected final channel. To exit this mode of operation and revert back to the traditional mode of operation of a multichannel ADC (as outlined in Figure 11), ensure that the write bit = 1 and SEQ1 = SEQ0 = 0 on the next serial transfer.

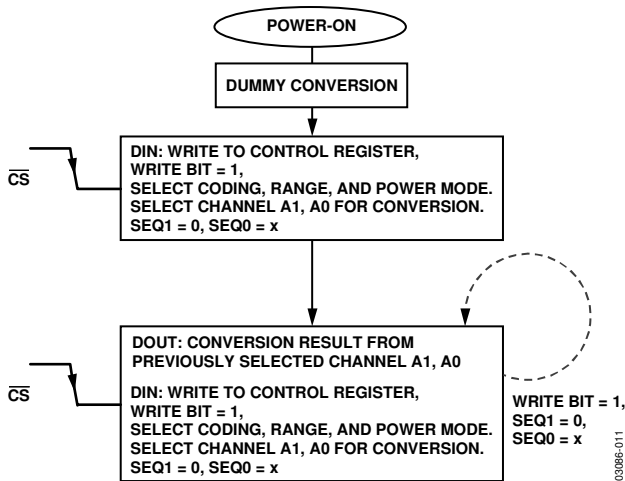

Figure 11. SEQ1 Bit = 0, SEQ0 Bit = X Flowchart

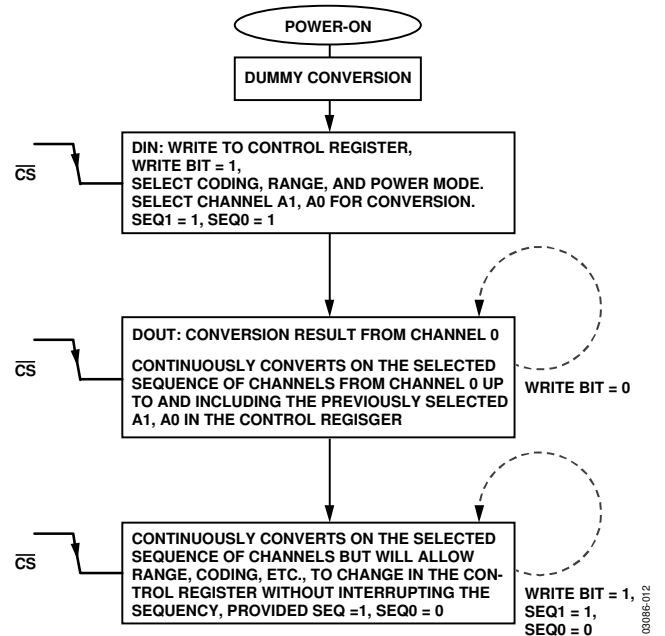

Figure 12. SEQ1 Bit = 1, SEQ0 Bit = 1 Flowchart

THEORY OF OPERATION

CIRCUIT INFORMATION

The AD7923 is a high speed, 4-channel, 12-bit single-supply ADC. The part can be operated from a 2.7 V to 5.25 V supply. When operated from either a 5 V or 3 V supply, the AD7923 is capable of throughput rates of 200 kSPS. The conversion time can be as short as 800 ns when provided with a 20 MHz clock.

The AD7923 provides the user with an on-chip track-and-hold ADC and with a serial interface housed in a 16-lead TSSOP package. The AD7923 has four, single-ended input channels with a channel sequencer, allowing the user to select a channel sequence through which the ADC can cycle with each consecutive \overline{CS} falling edge. The serial clock input accesses data from the part, controls the transfer of data written to the ADC, and provides the clock source for the successive approximation ADC. The analog input range is 0 V to REF_{IN} or 0 V to $2 \times REF_{IN}$, depending on the status of the RANGE bit in the control register. For the 0 to $2 \times REF_{IN}$ range, the part must be operated from a 4.75 V to 5.25 V AV_{DD} supply.

The AD7923 provides flexible power management options to allow the user to achieve the best power performance for a given throughput rate. These options are selected by programming the power management bits, PM1 and PM0, in the control register.

CONVERTER OPERATION

The AD7923 is a 12-bit successive approximation ADC based around a capacitive DAC. It can convert analog input signals in the range 0 V to REF_{IN} or 0 V to $2 \times REF_{IN}$. Figure 13 and Figure 14 show simplified schematics of the ADC. The ADC is comprised of a control logic, SAR, and capacitive DAC, which are used to add and subtract fixed amounts of charge from the sampling capacitor to bring the comparator back into a balanced condition. Figure 13 shows the ADC during its acquisition phase. SW2 is closed and SW1 is in Position A. The comparator is held in a balanced condition and the sampling capacitor acquires the signal on the selected V_{IN} channel.

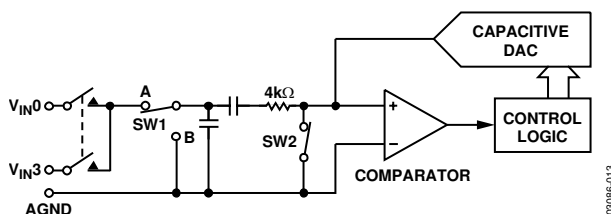

Figure 13. ADC Acquisition Phase

When the ADC starts a conversion (see Figure 14), SW2 opens and SW1 moves to Position B, causing the comparator to become unbalanced. The control logic and the capacitive DAC are used to add and subtract fixed amounts of charge from the sampling capacitor to bring the comparator back into balance.

When the comparator is rebalanced, the conversion is complete. The control logic generates the ADC output code. Figure 16 and Figure 17 show the ADC transfer functions.

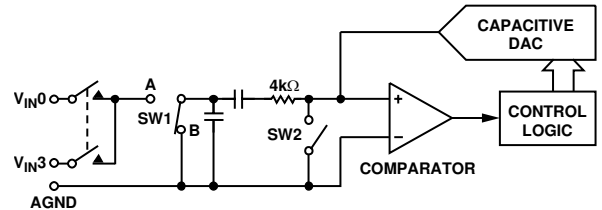

Figure 14. ADC Conversion Phase

Analog Input

Figure 15 shows an equivalent circuit of the analog input structure of the AD7923. The two diodes D1 and D2 provide ESD protection for the analog inputs. Care must be taken to ensure that the analog input signal never exceeds the supply rails by more than 200 mV; otherwise these diodes become forward-biased and start conducting current into the substrate. 10 mA is the maximum current these diodes can conduct without causing irreversible damage to the part. Capacitor C1, shown in Figure 15, is typically around 4 pF and can primarily be attributed to pin capacitance. The resistor R1 is a lumped component made up of the on resistance of the track-and-hold switch and includes the on resistance of the input multiplexer. The total resistance is typically about 400 Ω . Capacitor C2 is the ADC sampling capacitor and has a capacitance of 30 pF typically. For ac applications, removing high frequency components from the analog input signal is recommended by using an RC low-pass filter on the relevant analog input pin. In applications where harmonic distortion and the signal-to-noise ratio are critical, the analog input should be driven from a low impedance source. Large source impedances significantly affect the ac performance of the ADC. This may necessitate the use of an input buffer amplifier. The choice of the op amp is a function of the particular application.

When no amplifier is used to drive the analog input, the source impedance should be limited to low values. The maximum source impedance depends on the amount of THD that can be tolerated. The THD increases as the source impedance increases and performance degrades (see Figure 8).

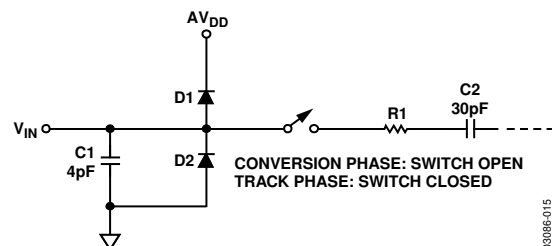

Figure 15. Equivalent Analog Input Circuit

ADC TRANSFER FUNCTION

The output coding of the AD7923 is either straight binary or twos complement, depending on the status of the LSB in the control register. The designed code transitions occur at successive LSB values (for example, 1 LSB, 2 LSBs). The LSB size is $REF_{IN} / 4096$ for the AD7923. The ideal transfer characteristic for the AD7923 when straight binary coding is selected is shown in Figure 16 and the ideal transfer characteristic for the AD7923 when twos complement coding is selected is shown in Figure 17.

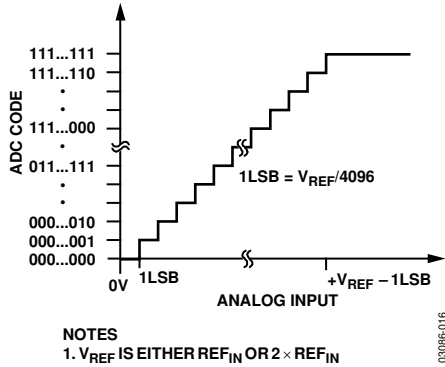

Figure 16. Straight Binary Transfer Characteristic

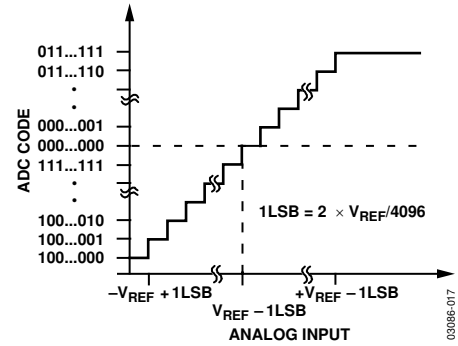

Figure 17. Twos Complement Transfer Characteristic with $REF_{IN} \pm REF_{IN}$ Input Range

Handling Bipolar Input Signals

Figure 18 shows how useful the combination of the $2 \times REF_{IN}$ input range and the twos complement output coding scheme is for handling bipolar input signals. If the bipolar input signal is biased around REF_{IN} and twos complement output coding is selected, then REF_{IN} becomes the zero-code point, $-REF_{IN}$ is negative full scale, and $+REF_{IN}$ becomes positive full scale with a dynamic range of $2 \times REF_{IN}$.

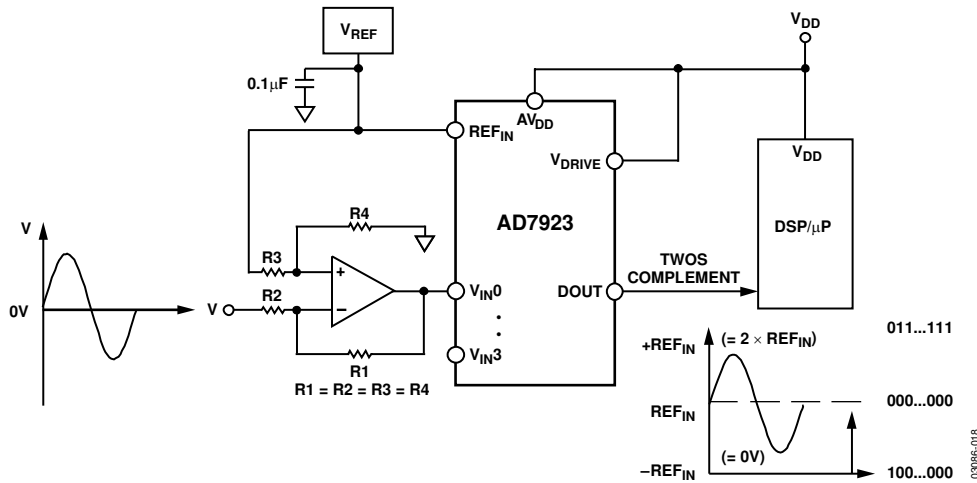
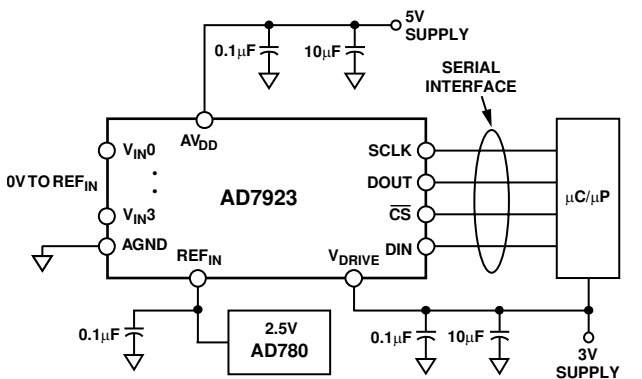

Figure 18. Handling Bipolar Signals

TYPICAL CONNECTION DIAGRAM

Figure 19 shows a typical connection diagram for the AD7923. In this setup the AGND pin is connected to the analog ground plane of the system. In Figure 19, REF_{IN} is connected to a decoupled 2.5 V supply from a reference source, the AD780, to provide an analog input range of 0 V to 2.5 V (if the range bit is 1) or 0 V to 5 V (if the range bit is 0). Although the AD7923 is connected to AV_{DD} of 5 V, the serial interface is connected to a 3 V microprocessor. The V_{DRIVE} pin of the AD7923 is connected to the same 3 V supply of the microprocessor to allow a 3 V logic interface (see the Digital Inputs section). The conversion result is output in a 16-bit word. This 16-bit data stream consists of two leading 0s, two address bits indicating which channel the conversion result corresponds to, followed by the 12 bits of conversion data. For applications where power consumption is a concern, the power-down modes should be used between conversions or bursts of several conversions to improve power performance. See the Modes of Operation section.



NOTES

1. ALL UNUSED INPUT CHANNELS MUST BE CONNECTED TO AGND.

03086-019

Figure 19. Typical Connection Diagram

Analog Input Selection

Any one of four analog input channels can be selected for conversion by programming the multiplexer with Address Bits ADD1 and ADD0 in the control register. The channel configurations are shown in Table 7.

The AD7923 can also be configured to automatically cycle through selected channels. The sequencer feature is accessed via the SEQ1 and SEQ0 bits in the control register (see Table 9). The AD7923 can be programmed to continuously convert on a number of consecutive channels in ascending order from Channel 0 to a selected final channel as determined by Channel Address Bits ADD1 and ADD0. This is possible if the SEQ1 and SEQ0 bits are set to 1, 1. The next serial transfer then acts on the sequence programmed by executing a conversion on Channel 0. The next serial transfer results in a conversion on Channel 1, and so on, until the channel selected via Address Bits ADD1 and ADD0 is reached. It is not necessary to write to

the control register again once a sequencer operation has been initiated. The write bit must be set to 0 or the DIN line must be set low to ensure that the control register is not accidentally overwritten or the sequence operation is interrupted. If the control register is written to at any time during the sequence, the user must ensure that the SEQ1 and SEQ0 bits are set to 1, 0 to avoid interrupting the automatic conversion sequence. This pattern continues until the AD7923 is written to and the SEQ1 and SEQ0 bits are configured with any bit combination except 1, 0, resulting in the termination of the sequence. If uninterupted, however (write bit = 0, or write bit = 1 and SEQ1 and SEQ0 bits are set to 1, 0), then upon completion of the sequence, the AD7923 sequencer returns to Channel 0 and commences the sequence again.

Regardless of which channel selection method is used, the 16-bit word output from the AD7923 during each conversion always contains two leading 0s, and two channel address bits that the conversion result corresponds to, followed by the 12-bit conversion result. (see the Serial Interface section).

Digital Inputs

The digital inputs applied to the AD7923 are not limited by the maximum ratings that limit the analog inputs. Instead, the digital inputs applied can go to 7 V and are not restricted by the AV_{DD} + 0.3 V limit as on the analog inputs.

Another advantage of SCLK, DIN, and \overline{CS} not being restricted by the AV_{DD} + 0.3 V limit is that possible power supply sequencing issues are avoided. If \overline{CS} , DIN, or SCLK are applied before AV_{DD}, there is no risk of latchup as there would be on the analog inputs if a signal greater than 0.3 V were applied prior to AV_{DD}.

V_{DRIVE}

The AD7923 also has the V_{DRIVE} feature. V_{DRIVE} controls the voltage at which the serial interface operates. V_{DRIVE} allows the ADC to easily interface to both 3 V and 5 V processors. For example, if the AD7923 were operated with an AV_{DD} of 5 V, the V_{DRIVE} pin could be powered from a 3 V supply. The AD7923 has a larger dynamic range with an AV_{DD} of 5 V while still being able to interface to 3 V processors. Care should be taken to ensure that V_{DRIVE} does not exceed AV_{DD} by more than 0.3 V (see the Absolute Maximum Ratings section).

Reference

An external reference source should be used to supply the 2.5 V reference to the AD7923. Errors in the reference source result in gain errors in the AD7923 transfer function and add to the specified full-scale errors of the part. A capacitor of at least 0.1 μF should be placed on the REFIN pin. Suitable reference sources for the AD7923 include the AD780, REF 192, and the AD1582.

If 2.5 V is applied to the REF_{IN} pin, the analog input range can be either 0 V to 2.5 V or 0 V to 5 V, depending on the setting of the range bit in the control register.

MODES OF OPERATION

The AD7923 has a number of different modes of operation, which are designed to provide flexible power management options. These options can be chosen to optimize the power dissipation/throughput rate ratio for differing application requirements. The mode of operation of the AD7923 is controlled by the power management bits, PM1 and PM0, in the control register, as detailed in Table 8. When power supplies are first applied to the AD7923, care should be taken to ensure that the part is placed in the required mode of operation (see the Powering Up the AD7923 section).

Normal Mode (PM1 = PM0 = 1)

This mode is intended for the fastest throughput rate performance where the user does not have to worry about power-up time since the AD7923 remains fully powered at all times. Figure 20 shows the general diagram of the operation of the AD7923 in this mode.

The conversion is initiated on the falling edge of \overline{CS} and the track-and-hold enters hold mode, as described in the Serial Interface section. The data presented to the AD7923 on the DIN line during the first 12 clock cycles of the data transfer is loaded into the control register (provided the write bit is set to 1). The part remains fully powered up in normal mode at the end of the conversion as long as PM1 and PM0 are set to 1 in the write transfer during that same conversion. To ensure continued operation in normal mode, PM1 and PM0 must both be loaded with 1 on every data transfer, assuming a write operation is taking place. If the write bit is set to 0, the power management bits are left unchanged and the part remains in normal mode.

Sixteen serial clock cycles are required to complete the conversion and access the conversion result. The track-and-hold go back into track on the 14th SCLK falling edge. \overline{CS} may then idle high until the next conversion or may idle low until sometime prior to the next conversion (effectively idling \overline{CS} low).

For specified performance, the throughput rate should not exceed 200 kSPS, which means there should be no less than 5 μ s between consecutive falling edges of \overline{CS} when converting. The actual frequency of the SCLK used determines the duration of the conversion within this 5 μ s cycle; however, once a conversion is complete, and \overline{CS} has returned high, a minimum of the quiet time, t_{QUIET} , must elapse before bringing \overline{CS} low again to initiate another conversion.

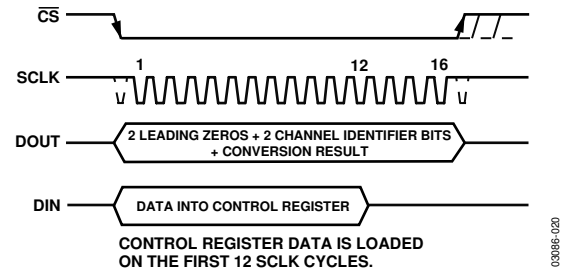

Figure 20. Normal Mode Operation

Full Shutdown (PM1 = 1, PM0 = 0)

In this mode, all internal circuitry on the AD7923 is powered down. The part retains information in the control register during full shutdown. The AD7923 remains in full shutdown until the power management bits in the control register, PM1 and PM0, are changed.

If a write to the control register occurs while the part is in full shutdown, with the power management bits changed to PM0 = PM1 = 1, normal mode, the part begins to power up on the \overline{CS} rising edge. The track-and-hold that was in hold while the part was in full shutdown returns to tracking on the 14th SCLK falling edge. A full 16-SCLK transfer must occur to ensure that the control register contents are updated; however, the DOUT line is not driven during this wake-up transfer.

To ensure that the part is fully powered up, $t_{POWER\ UP}$ (t_{12}) should have elapsed before the next \overline{CS} falling edge; otherwise invalid data is read if a conversion is initiated before this time. Figure 21 shows the general diagram for this sequence.

Auto Shutdown (PM1 = 0, PM0 = 1)

In this mode, the AD7923 automatically enters shutdown at the end of each conversion when the control register is updated. When the part is in shutdown, the track-and-hold is in hold mode. Figure 22 shows the general diagram of the operation of the AD7923 in this mode. In shutdown mode all internal circuitry on the AD7923 is powered down. The part retains information in the control register during shutdown. The AD7923 remains in shutdown until the next \overline{CS} falling edge it receives. On this \overline{CS} falling edge, the track-and-hold that was in hold while the part was in shutdown returns to tracking. Wake-up time from auto shutdown is 1 μ s maximum, and the user should ensure that 1 μ s has elapsed before attempting a valid conversion. When running the AD7923 with a 20 MHz clock, one dummy 16 SCLK transfer should be sufficient to ensure that the part is fully powered up. During this dummy transfer, the contents of the control register should remain unchanged, therefore the write bit should be 0 on the DIN line. Depending on the SCLK frequency used, this dummy transfer may affect the achievable throughput rate of the part, with every other data transfer being a valid conversion result. If, for example, the maximum SCLK frequency of 20 MHz is used, the auto shut-down mode could be used at the full throughput rate of 200 kSPS without affecting the throughput rate at all.

Only a portion of the cycle time is taken up by the conversion time and the dummy transfer for wakeup. In this mode, the power consumption of the part is greatly reduced because the part enters shutdown at the end of each conversion. When the control register is programmed to move into auto shutdown, it does so at the end of the conversion. The user can move the ADC in and out of the low power state by controlling the \overline{CS} signal.

POWERING UP THE AD7923

When supplies are first applied to the AD7923, the ADC can power up in any of the operating modes of the part. To ensure that the part is placed into the required operating mode, the user should perform a dummy cycle operation, as outlined in Figure 23 through Figure 25.

The dummy conversion operation must be performed to place the part into the desired mode of operation. To ensure that the part is in normal mode, this dummy cycle operation can be performed with the DIN line tied high, that is, PM1, PM0 = 1, 1 (depending on other required settings in the control register), but the minimum power-up time of 1 μ s must be allowed from the rising edge of \overline{CS} , where the control register is updated,

before attempting the first valid conversion. This is to allow for the possibility that the part initially powered up in shutdown.

If the desired mode of operation is full shutdown, then again only one dummy cycle is required after supplies are applied. In this dummy cycle, the user simply sets the power management bits, PM1, PM0 = 1, 0, and upon the rising edge of \overline{CS} at the end of that serial transfer, the part enters full shutdown. If the desired mode of operation is auto shutdown after supplies are applied, two dummy cycles are required, the first with DIN tied high and the second dummy cycle to set the power management bits PM1 and PM0 = 0,1. On the second \overline{CS} rising edge after the supplies are applied, the control register contains the correct information and the part enters auto shutdown mode as programmed. If power consumption is of critical concern, then in the first dummy cycle the user may set PM1, PM0 = 1, 0, that is, full shutdown, and then place the part into auto shutdown in the second dummy cycle. For illustration purposes, Figure 25 is shown with DIN tied high on the first dummy cycle in this case.

Figure 23, Figure 24, and Figure 25 each show the required dummy cycle(s) after supplies are applied in the case of normal mode, full shutdown mode, and auto shutdown mode, respectively, being the desired mode of operation.

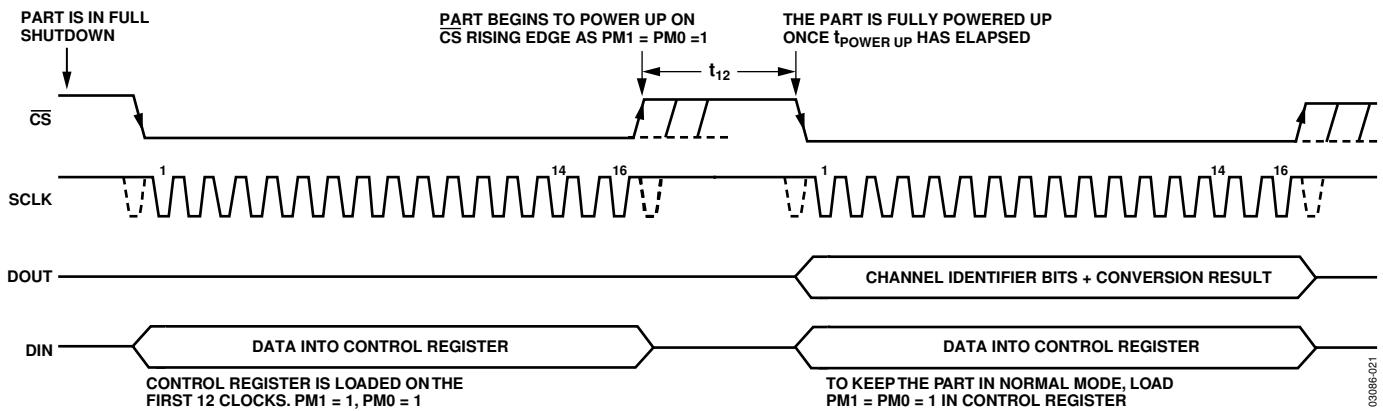

Figure 21. Full Shutdown Mode Operation

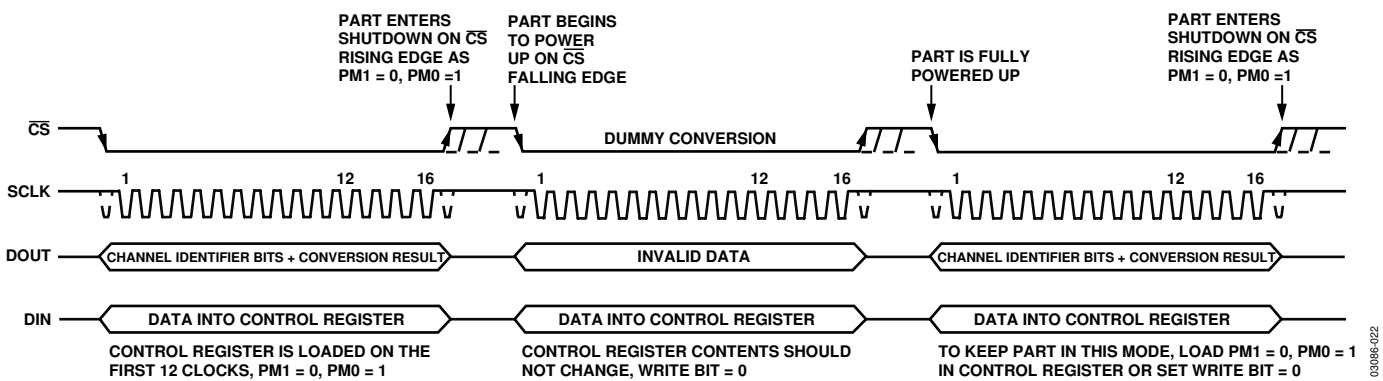

Figure 22. Auto Shutdown Mode Operation

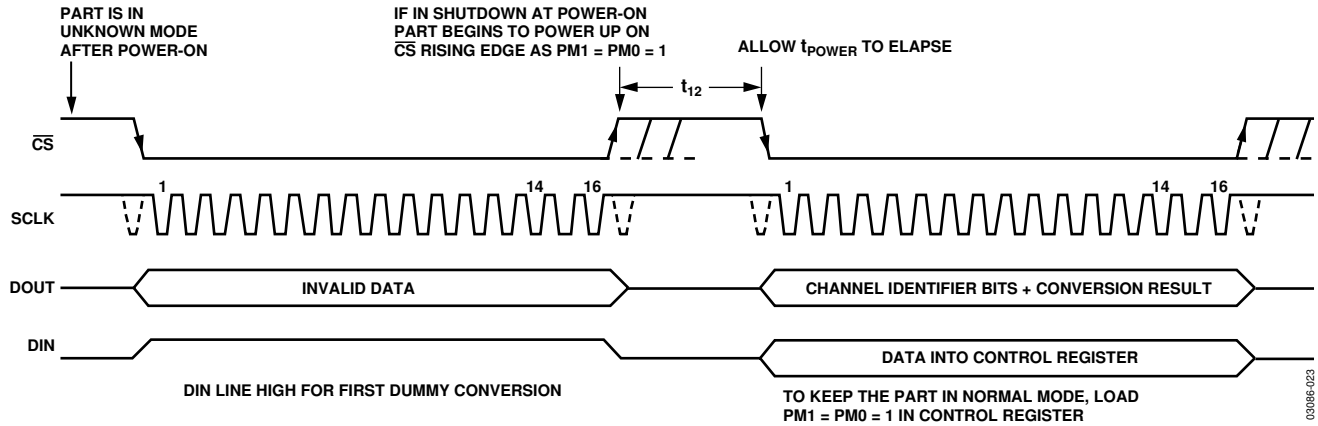

Figure 23. Placing the AD7923 into Normal Mode after Supplies are First Applied

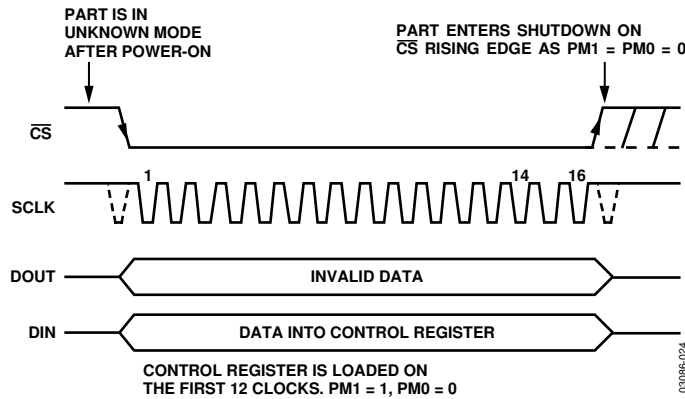

Figure 24. Placing the AD7923 into Full Shutdown Mode after Supplies are First Applied

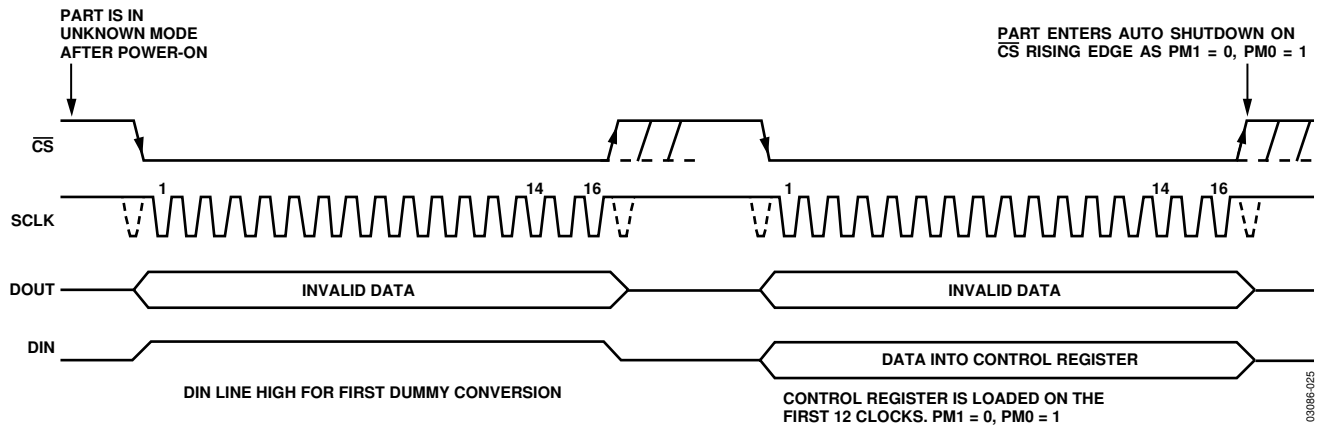

Figure 25. Placing the AD7923 into Auto Shutdown Mode after Supplies are First Applied

POWER vs. THROUGHPUT RATE

In auto shutdown mode, the average power consumption of the ADC can be reduced at any given throughput rate. The power saving depends on the SCLK frequency used, that is, conversion time. In some cases where the conversion time is a large proportion of the cycle time, the throughput rate needs to be reduced to take advantage of the power-down modes. Assuming a 20 MHz SCLK is used, the conversion time is 800 ns, but the

cycle time is 5 μ s when the sampling rate is at a maximum of 200 kSPS. If the AD7923 is placed into shutdown for the remainder of the cycle time, then on average far less power is consumed in every cycle compared to leaving the device in normal mode. Furthermore, Figure 26 shows how, as the throughput rate is reduced, the part remains in its shutdown longer and the average power consumption drops accordingly over time.

For example, if the AD7923 is operated in a continuous sampling mode, with a throughput rate of 200 kSPS and an SCLK of 20 MHz ($AV_{DD} = 5\text{ V}$), and the device is placed in auto shutdown mode, that is, if $PM1 = 0$ and $PM0 = 1$, then the power consumption is calculated as follows:

The maximum power dissipation during conversion is 13.5 mW ($I_{DD} = 2.7\text{ mA max}$, $AV_{DD} = 5\text{ V}$). If the power-up time from auto shutdown is one dummy cycle, that is, $1\text{ }\mu\text{s}$, and the remaining conversion time is another cycle, that is, 800 ns , then the AD7923 can be said to dissipate 13.5 mW for $1.8\text{ }\mu\text{s}$ during each conversion cycle. For the remainder of the conversion cycle, $3.2\text{ }\mu\text{s}$, the part remains in shutdown. The AD7923 can be said to dissipate $2.5\text{ }\mu\text{W}$ for the remaining $3.2\text{ }\mu\text{s}$ of the conversion cycle. If the throughput rate is 200 kSPS, the cycle time is $5\text{ }\mu\text{s}$ and the average power dissipated during each cycle is $(1.8/5) \times (13.5\text{ mW}) + (3.2/5) \times (2.5\text{ }\mu\text{W}) = 4.8616\text{ mW}$.

Figure 26 shows the maximum power vs. throughput rate when using the auto shutdown mode with 5 V and 3 V supplies.

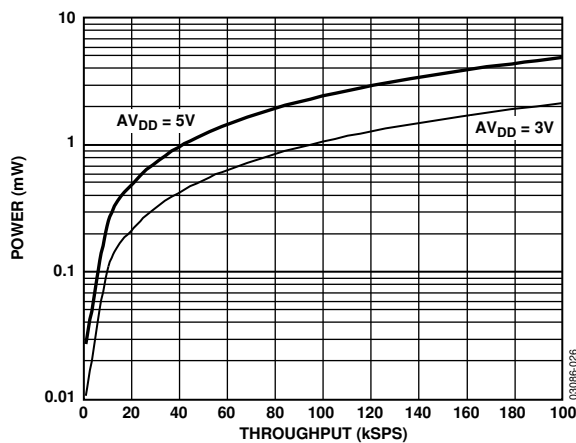

Figure 26. Power vs. Throughput Rate

SERIAL INTERFACE

Figure 27 shows the detailed timing diagrams for serial interfacing to the AD7923. The serial clock provides the conversion clock and controls the transfer of information to and from the AD7923 during each conversion.

The \overline{CS} signal initiates the data transfer and conversion process. The falling edge of \overline{CS} puts the track-and-hold into hold mode and takes the bus out of three-state; the analog input is sampled at this point. The conversion is also initiated at this point and requires 16 SCLK cycles to complete. The track-and-hold returns to track mode at Point B on the 14th SCLK falling edge, as shown in Figure 27. On the 16th SCLK falling edge the DOUT line returns to three-state. If the rising edge of \overline{CS} occurs before 16 SCLKs have elapsed, the conversion is terminated, the DOUT line returns to three-state, and the control register is not updated;

otherwise DOUT returns to three-state on the 16th SCLK falling edge, as shown in Figure 27.

Sixteen serial clock cycles are required to perform the conversion process and to access data from the AD7923. For the AD7923, the 12 bits of data are preceded by two leading 0s and Channel Address Bits $ADD1$ and $ADD0$, identifying which channel the result corresponds to. \overline{CS} going low clocks out the first leading 0 to be read by the microcontroller or DSP on the first falling edge of SCLK. The first falling edge of SCLK also clocks out the second leading 0 to be read by the microcontroller or DSP on the second SCLK falling edge, and so on. The remaining two address bits and 12 data bits are then clocked out by subsequent SCLK falling edges, beginning with the first Address Bit $ADD1$, thus the second falling clock edge on the serial clock has the second leading 0 and also clocks out Address Bit $ADD1$. The final bit in the data transfer is valid on the 16th falling edge, having been clocked out on the previous (15th) falling edge.

Writing information to the control register takes place on the first 12 falling edges of SCLK in a data transfer, assuming the MSB, that is, the write bit, has been set to 1.

The 16-bit word read from the AD7923 always contain two leading 0s, two channel address bits that the conversion result corresponds to, followed by the 12-bit conversion result.

Writing Between Conversions

As outlined in the operating modes section, not less than $5\text{ }\mu\text{s}$ should be left between consecutive valid conversions. There is one exception, however: consider the case when writing to the AD7923 to power it up from shutdown prior to a valid conversion. The user must write to the part to tell it to power up before it can convert successfully. Once the serial write to power up has finished, the user might want to perform the conversion as soon as possible without waiting an additional $5\text{ }\mu\text{s}$ before bringing \overline{CS} low for the conversion. In this case, as long as there is a minimum of $5\text{ }\mu\text{s}$ between each valid conversion, only the quiet time between the \overline{CS} rising edge at the end of the write to power up and the next \overline{CS} falling edge needs to be met. Figure 28 illustrates this point. Note that when writing to the AD7923 between these valid conversions, the DOUT line is not driven during the extra write operation.

It is critical that an extra write operation as outlined above is never issued between valid conversions when the AD7923 is executing a sequence function, because the falling edge of \overline{CS} in the extra write moves the mux to the next channel in the sequence. This means that when the next valid conversion takes place a channel result would be missed.

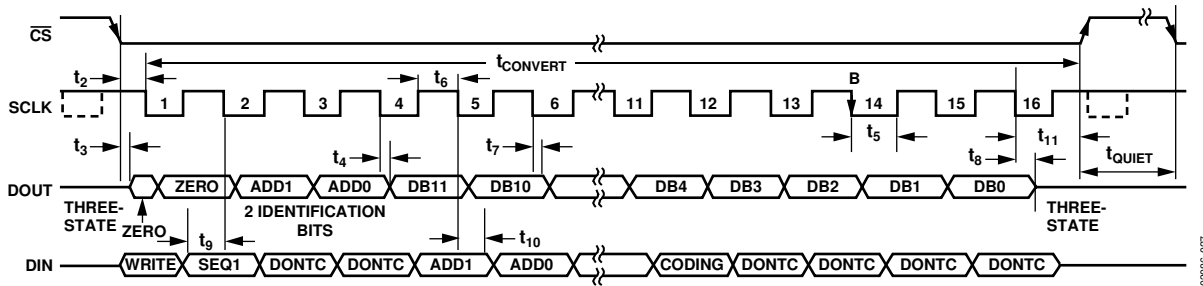

Figure 27. Serial Interface Timing Diagram

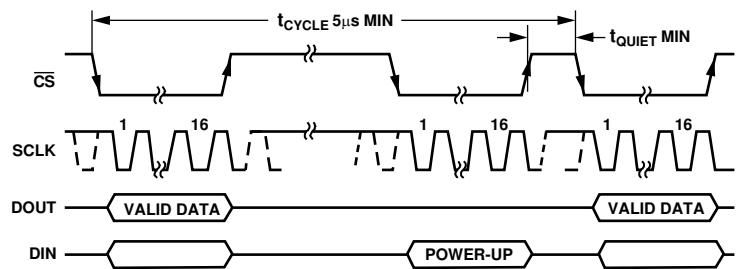

Figure 28. General Timing Diagram

MICROPROCESSOR INTERFACING

The serial interface on the AD7923 allows the part to be directly connected to a range of many different microprocessors. This section explains how to interface the AD7923 with some of the more common microcontroller and DSP serial interface protocols.

AD7923-to-TMS320C541

The serial interface on the TMS320C541 uses a continuous serial clock and frame synchronization signals to synchronize the data transfer operations with peripheral devices like the AD7923. The CS input allows easy interfacing between the TMS320C541 and the AD7923 without any glue logic required. The serial port of the TMS320C541 is set up to operate in burst mode with internal CLKX0 (Tx serial clock on Serial Port 0) and FSX0 (Tx frame sync from Serial Port 0). The serial port control register (SPC) must have the following setup: FO = 0, FSM = 1, MCM = 1, and TXM = 1. The connection diagram is shown in Figure 29. It should be noted that for signal processing applications, it is imperative that the frame synchronization signal from the TMS320C541 provides equidistant sampling. The VDRIVE pin of the AD7923 takes the same supply voltage as the TMS320C541. This allows the ADC to operate at a higher voltage than the serial interface, that is, the TMS320C541, if necessary.

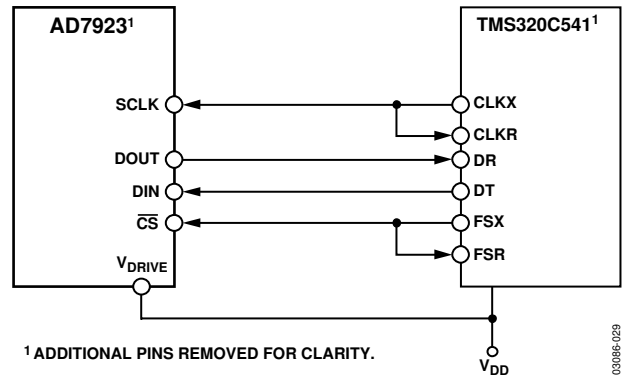

Figure 29. Interfacing to the TMS320C541

AD7923-to-ADSP-21xx

The ADSP-21xx family of DSPs is interfaced directly to the AD7923 without any glue logic required. The VDRIVE pin of the AD7923 takes the same supply voltage as the ADSP-218x, which allows the ADC to operate at a higher voltage than the serial interface, that is, ADSP-218x, if necessary.

The SPORT0 control register should be set up as follows:

- TFSW = RFSW = 1, alternate framing
- INVRFS = INVTFS = 1, active low frame signal
- DTYPE = 00, right justify data
- SLEN = 1111, 16-bit data-words
- ISCLK = 1, internal serial clock
- TFSR = RFSR = 1, frame every word
- IRFS = 0
- ITFS = 1

The connection diagram is shown in Figure 30. The ADSP-218x has the TFS and RFS of the SPORT tied together, with TFS set as an output and RFS set as an input. The DSP operates in alternate framing mode and the SPORT control register is set up as described. The frame synchronization signal generated on the TFS is tied to \overline{CS} and, as with all signal processing applications, equidistant sampling is necessary. However, in this example, the timer interrupt is used to control the sampling rate of the ADC, and under certain conditions equidistant sampling might not be achieved.

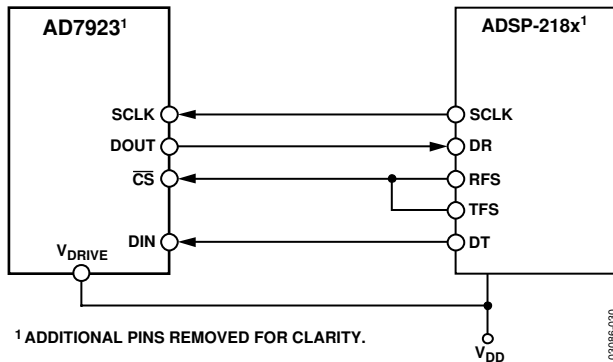

Figure 30. Interfacing to the ADSP-218x

The timer register, for instance, is loaded with a value that provides an interrupt at the required sample interval. When an interrupt is received, a value is transmitted with TFS/DT (ADC control word). The TFS is used to control the RFS and therefore the reading of data. The frequency of the serial clock is set in the SCLKDIV register. When the instruction to transmit with TFS is given (that is, AX0 = TX0), the state of the SCLK is checked. The DSP waits until the SCLK has gone high, low, and high before the transmission starts. If the timer and SCLK values are chosen such that the instruction to transmit occurs on or near the rising edge of SCLK, the data can be transmitted, or it can wait until the next clock edge.

For example, if the ADSP-2189 has a 20 MHz crystal such that it has a master clock frequency of 40 MHz, then the master cycle time is 25 ns. If the SCLKDIV register is loaded with the value 3, then a SCLK of 5 MHz is obtained, and eight master clock periods elapse for every SCLK period. Depending on the

throughput rate selected, if the timer registers are loaded with the value 803, 100.5 SCLKs occur between interrupts and subsequently between transmit instructions. This situation results in nonequidistant sampling since the transmit instruction occurs on a SCLK edge. If the number of SCLKs between interrupts is an integer of N, equidistant sampling is implemented by the DSP.

AD7923-to-DSP563xx

The connection diagram in Figure 31 shows how the AD7923 can be connected to the synchronous serial interface (ESSI) of the DSP563xx family of DSPs from Motorola. Each ESSI (two on board) is operated in synchronous mode (SYN bit in CRB = 1), with an internally generated word length frame sync for both Tx and Rx (bits FSL1 = 0 and FSL0 = 0 in CRB). Normal operation of the ESSI is selected by making MOD = 0 in the CRB. Set the word length to 16 by setting bits WL1 = 1 and WL0 = 0 in CRA. The FSP bit in the CRB should be set to 1 so the frame sync is negative. It should be noted that for signal processing applications, it is imperative that the frame synchronization signal from the DSP563xx provides equidistant sampling.

In the example shown in Figure 31, the serial clock is taken from the ESSI, therefore the SCK0 pin must be set as an output, SCKD = 1. The V_{DRIVE} pin of the AD7923 takes the same supply voltage as the DSP563xx, which allows the ADC to operate at a higher voltage than the serial interface, that is, DSP563xx, if necessary.

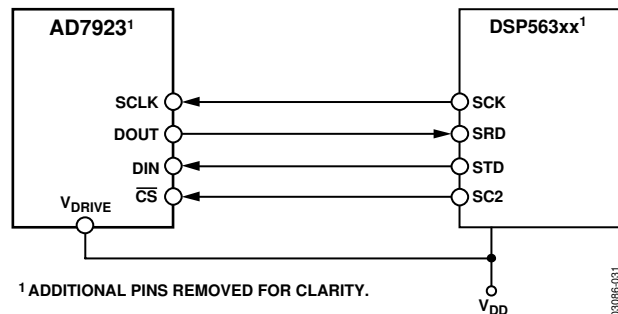

Figure 31. Interfacing to the DSP563xx

APPLICATION HINTS

GROUNDING AND LAYOUT

The AD7923 has very good immunity to noise on the power supplies as can be seen by the PSRR vs. supply ripple frequency plot, Figure 6. However, care should still be taken in grounding and layout.

The printed circuit board that houses the AD7923 should be designed such that the analog and digital sections are separated and confined to certain areas of the board. This facilitates the use of ground planes that can be separated easily. A minimum etch technique is generally best for ground planes since it gives the best shielding. All three AGND pins of the AD7923 should be sunk into the AGND plane. Digital and analog ground planes should be joined at only one place. If the AD7923 is in a system where multiple devices require an AGND to DGND connection, the connection should still be made at one point only, a star ground point that should be established as close as possible to the AD7923.

Avoid running digital lines under the device since they couple noise onto the die. The analog ground plane should be allowed to run under the AD7923 to avoid noise coupling. The power supply lines to the AD7923 should use as large a trace as possible to provide low impedance paths and reduce the effects of glitches on the power supply line. Fast switching signals, like clocks, should be shielded with digital ground to avoid radiating noise to other sections of the board, and clock signals should

never be run near the analog inputs. Avoid crossover of digital and analog signals. Traces on opposite sides of the board should run at right angles to each other. This reduces the effects of feedthrough through the board. A microstrip technique is by far the best technique, but is not always possible with a double-sided board. In this technique, the component side of the board is dedicated to ground planes, while signals are placed on the solder side.

Good decoupling is also important. All analog supplies should be decoupled with 10 μF tantalum in parallel with 0.1 μF capacitors to AGND. To achieve the best results from these decoupling components, they must be placed as close as possible to the device, ideally right up against the device. The 0.1 μF capacitors should have low effective series resistance (ESR) and low effective series inductance (ESI), such as the common ceramic types or surface mount types, which provide a low impedance path to ground at high frequencies to handle transient currents from internal logic switching.

OUTLINE DIMENSIONS

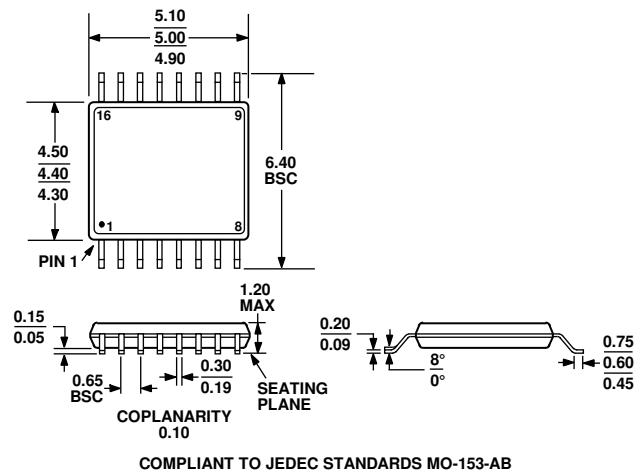

Figure 32. 16-Lead Thin Shrink Small Outline Package [TSSOP]
(RU-16)
Dimensions shown in millimeters

ORDERING GUIDE

Model ^{1, 2}	Temperature Range	Linearity Error (LSB) ³	Package Option	Package Description
AD7923BRU	-40°C to +125°C	±1	RU-16	16-Lead TSSOP
AD7923BRUZ	-40°C to +125°C	±1	RU-16	16-Lead TSSOP
AD7923BRUZ-REEL	-40°C to +125°C	±1	RU-16	16-Lead TSSOP
AD7923BRUZ-REEL7	-40°C to +125°C	±1	RU-16	16-Lead TSSOP
AD7923WYRUZ-REEL7	-40°C to +125°C	±1	RU-16	16-Lead TSSOP

¹ Z = RoHS Compliant Part.

² W = Qualified for Automotive Applications.

³ Linearity error refers to integral linearity error.

AUTOMOTIVE PRODUCTS

The AD7923W models are available with controlled manufacturing to support the quality and reliability requirements of automotive applications. Note that these automotive models may have specifications that differ from the commercial models; therefore, designers should review the Specifications section of this data sheet carefully. Only the automotive grade products shown are available for use in automotive applications. Contact your local Analog Devices account representative for specific product ordering information and to obtain the specific Automotive Reliability reports for these models.