



Chipsmall Limited consists of a professional team with an average of over 10 year of expertise in the distribution of electronic components. Based in Hongkong, we have already established firm and mutual-benefit business relationships with customers from,Europe,America and south Asia,supplying obsolete and hard-to-find components to meet their specific needs.

With the principle of “Quality Parts,Customers Priority,Honest Operation,and Considerate Service”,our business mainly focus on the distribution of electronic components. Line cards we deal with include Microchip,ALPS,ROHM,Xilinx,Pulse,ON,Everlight and Freescale. Main products comprise IC,Modules,Potentiometer,IC Socket,Relay,Connector.Our parts cover such applications as commercial,industrial, and automotives areas.

We are looking forward to setting up business relationship with you and hope to provide you with the best service and solution. Let us make a better world for our industry!



Contact us

Tel: +86-755-8981 8866 Fax: +86-755-8427 6832

Email & Skype: info@chipsmall.com Web: www.chipsmall.com

Address: A1208, Overseas Decoration Building, #122 Zhenhua RD., Futian, Shenzhen, China



6-Lead SOT-23 ADC Driver for the 8-/10-Lead Family of 14-/16-/18-Bit PuLSAR ADC Evaluation Boards

FEATURES

- Enables quick breadboarding/prototyping
- User defined circuit configuration
- Edge-mounted header for easy connections
- Standalone power supply for power supply adjustments

COMPATIBLE PuLSAR EVALUATION BOARDS

8-lead PuLSAR evaluation board

16-bit ADCs: [AD7683](#), [AD7684](#), [AD7694](#)

10-lead PuLSAR evaluation board

14-bit ADCs: [AD7942](#), [AD7946](#)

16-bit ADCs: [AD7685](#), [AD7686](#), [AD7687](#), [AD7688](#), [AD7693](#), [AD7980](#), [AD7983](#), [AD7988-5](#)

18-bit ADCs: [AD7690](#), [AD7691](#), [AD7982](#), [AD7984](#), [AD7989-5](#)

GENERAL DESCRIPTION

The Analog Devices, Inc., 6-lead SOT-23 ADC driver is used to evaluate the performance of amplifiers in an SOT package with the 8-/10-lead family of 14-/16-/18-bit PuLSAR® ADC evaluation boards. This add-on board can easily be inserted on either side of the ADC evaluation board using the 7-pin header. Figure 1 shows the mounted SOT-23 ADC driver on the ADC evaluation board. Figure 5 and Figure 6 show the bare SOT-23 ADC driver—component side and solder side, respectively.

Figure 2 shows the evaluation board schematic. Figure 3 shows how the user can configure the 6-lead SOT-23 ADC driver to drive a single-ended ADC. Figure 4 shows how the user can configure the 6-lead SOT-23 ADC driver to drive a single-ended signal into a differential ADC. The bill of materials is listed in Table 1.

MOUNTED 6-LEAD SOT-23 ADC DRIVER

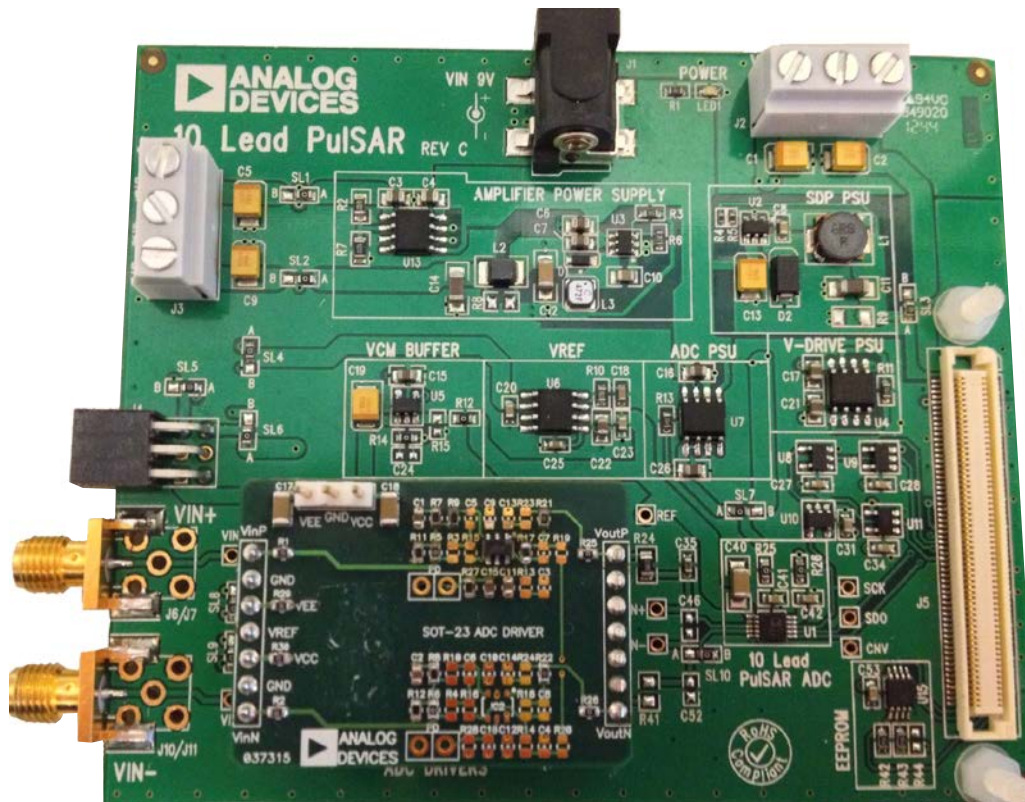

NOTES

1. TO ROUTE THE INPUTS, OUTPUTS, AND SUPPLIES ONTO THE 6-LEAD SOT-23 ADC DRIVER PROPERLY, R20, R21, R28, R35, R36, AND R40 ON THE ADC EVALUATION BOARD MUST BE REMOVED. FOR MORE INFORMATION, SEE THE UG-340 FOR THE ADC EVALUATION BOARD SCHEMATICS.

Figure 1. A 6-Lead SOT-23 ADC Driver Mounted onto a 10-Lead PuLSAR ADC Evaluation Board

12232-001

TABLE OF CONTENTS

Features	1	Evaluation Board Schematics and Artwork.....	3
Compatible PulsAR Evaluation Boards	1	Populated Schematics	4
General Description	1	Evaluation Board Layout Pattern	6
Mounted 6-Lead SOT-23 ADC Driver	1	Bill of Materials.....	7
Revision History	2		

REVISION HISTORY

5/14—Revision 0: Initial Version

EVALUATION BOARD SCHEMATICS AND ARTWORK

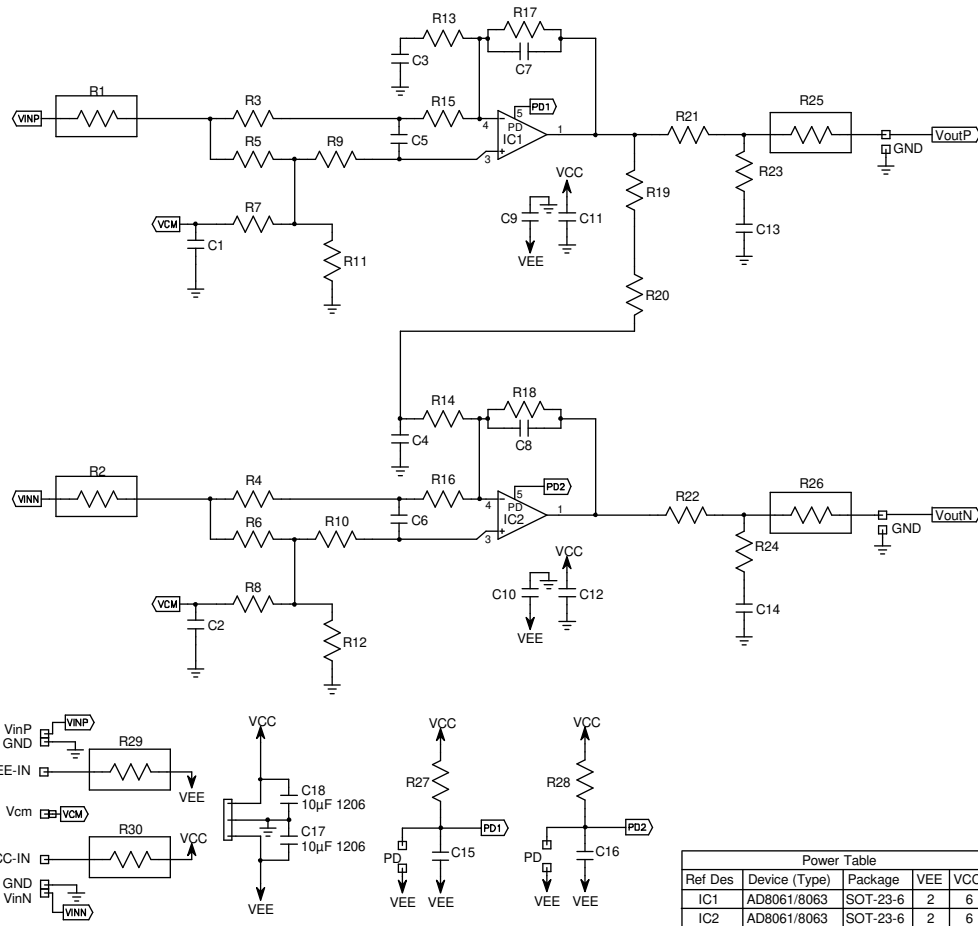

NOTES
 TO ROUTE THE INPUTS, OUTPUTS, AND SUPPLIES ONTO THE 6-LEAD SOT-23 ADC DRIVER PROPERLY, R20, R21, R28, R35, R36, AND R40 ON THE ADC EVALUATION BOARD MUST BE REMOVED. FOR MORE INFORMATION, SEE THE UG-340 FOR THE ADC EVALUATION BOARD SCHEMATICS.

Figure 2. 6-Lead SOT-23 ADC Driver Schematic

12232-904

POPULATED SCHEMATICS

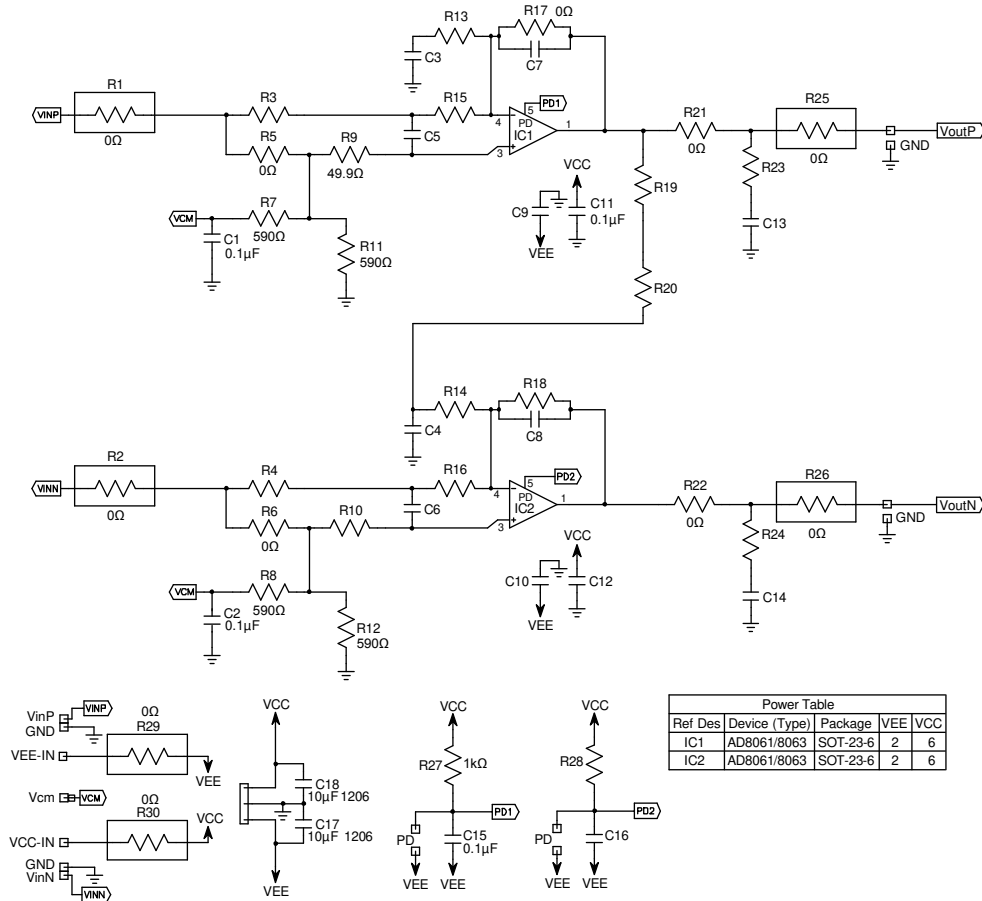

NOTES

TO ROUTE THE INPUTS, OUTPUTS, AND SUPPLIES ONTO THE 6-LEAD SOT-23 ADC DRIVER PROPERLY, R20, R21, R28, R35, R36, AND R40 ON THE ADC EVALUATION BOARD MUST BE REMOVED. FOR MORE INFORMATION, SEE THE UG-340 FOR THE ADC EVALUATION BOARD SCHEMATICS.

Figure 3. Configuring the 6-Lead SOT-23 ADC Driver to Drive a Single-Ended ADC

122932-005

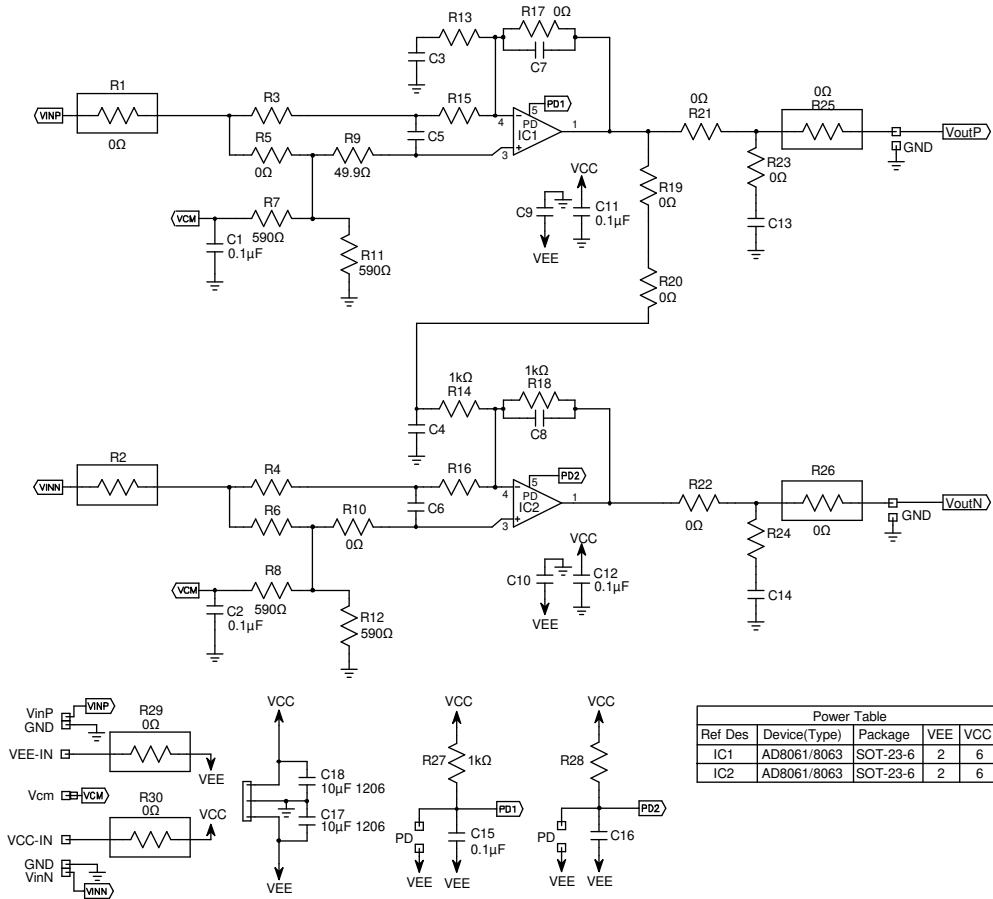

NOTES

TO ROUTE THE INPUTS, OUTPUTS, AND SUPPLIES ONTO THE 6-LEAD SOT-23 ADC DRIVER PROPERLY, R20, R21, R28, R35, R36, AND R40 ON THE ADC EVALUATION BOARD MUST BE REMOVED. FOR MORE INFORMATION, SEE THE UG-340 FOR THE ADC EVALUATION BOARD SCHEMATICS.

Figure 4. Configuring the 6-Lead SOT-23 ADC Driver to Drive a Single-Ended Signal into a Differential ADC

12232-006

EVALUATION BOARD LAYOUT PATTERN

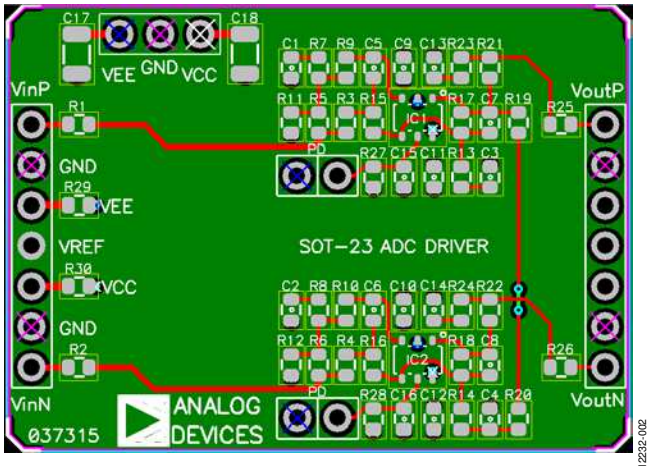

Figure 5. 6-Lead SOT-23 ADC Driver, Component Side

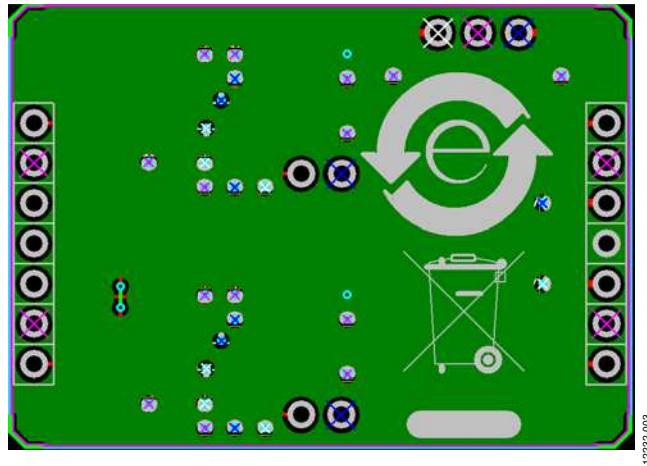

Figure 6. 6-Lead SOT-23 ADC Driver, Solder Side

BILL OF MATERIALS

Table 1.

Quantity	Reference Designator	Description	Package
3	VEE, GND, VCC	3-pin power supply header	3-pin header
8	VinP, VinN, GND, VCC, VEE, VREF, VOUTP, VOUTN	Supply input and output connections	7-pin header
1	PD	Jumper to control power-down	2-pin jumper
2	C17, C18	10 μ F capacitor	1206
16	C1 to C16	Capacitor, user defined	0603
1	DUT	See the amplifier data sheet for SOT-23 package dimensions	SOT-23
30	R1 to R30	Resistor, user defined	R0603

NOTES

**ESD Caution**

ESD (electrostatic discharge) sensitive device. Charged devices and circuit boards can discharge without detection. Although this product features patented or proprietary protection circuitry, damage may occur on devices subjected to high energy ESD. Therefore, proper ESD precautions should be taken to avoid performance degradation or loss of functionality.

Legal Terms and Conditions

By using the evaluation board discussed herein (together with any tools, components documentation or support materials, the "Evaluation Board"), you are agreeing to be bound by the terms and conditions set forth below ("Agreement") unless you have purchased the Evaluation Board, in which case the Analog Devices Standard Terms and Conditions of Sale shall govern. Do not use the Evaluation Board until you have read and agreed to the Agreement. Your use of the Evaluation Board shall signify your acceptance of the Agreement. This Agreement is made by and between you ("Customer") and Analog Devices, Inc. ("ADI"), with its principal place of business at One Technology Way, Norwood, MA 02062, USA. Subject to the terms and conditions of the Agreement, ADI hereby grants to Customer a free, limited, personal, temporary, non-exclusive, non-sublicensable, non-transferable license to use the Evaluation Board FOR EVALUATION PURPOSES ONLY. Customer understands and agrees that the Evaluation Board is provided for the sole and exclusive purpose referenced above, and agrees not to use the Evaluation Board for any other purpose. Furthermore, the license granted is expressly made subject to the following additional limitations: Customer shall not (i) rent, lease, display, sell, transfer, assign, sublicense, or distribute the Evaluation Board; and (ii) permit any Third Party to access the Evaluation Board. As used herein, the term "Third Party" includes any entity other than ADI, Customer, their employees, affiliates and in-house consultants. The Evaluation Board is NOT sold to Customer; all rights not expressly granted herein, including ownership of the Evaluation Board, are reserved by ADI. CONFIDENTIALITY. This Agreement and the Evaluation Board shall all be considered the confidential and proprietary information of ADI. Customer may not disclose or transfer any portion of the Evaluation Board to any other party for any reason. Upon discontinuation of use of the Evaluation Board or termination of this Agreement, Customer agrees to promptly return the Evaluation Board to ADI. ADDITIONAL RESTRICTIONS. Customer may not disassemble, decompile or reverse engineer chips on the Evaluation Board. Customer shall inform ADI of any occurred damages or any modifications or alterations it makes to the Evaluation Board, including but not limited to soldering or any other activity that affects the material content of the Evaluation Board. Modifications to the Evaluation Board must comply with applicable law, including but not limited to the RoHS Directive. TERMINATION. ADI may terminate this Agreement at any time upon giving written notice to Customer. Customer agrees to return to ADI the Evaluation Board at that time. LIMITATION OF LIABILITY. THE EVALUATION BOARD PROVIDED HEREUNDER IS PROVIDED "AS IS" AND ADI MAKES NO WARRANTIES OR REPRESENTATIONS OF ANY KIND WITH RESPECT TO IT. ADI SPECIFICALLY DISCLAIMS ANY REPRESENTATIONS, ENDORSEMENTS, GUARANTEES, OR WARRANTIES, EXPRESS OR IMPLIED, RELATED TO THE EVALUATION BOARD INCLUDING, BUT NOT LIMITED TO, THE IMPLIED WARRANTY OF MERCHANTABILITY, TITLE, FITNESS FOR A PARTICULAR PURPOSE OR NON-INFRINGEMENT OF INTELLECTUAL PROPERTY RIGHTS. IN NO EVENT WILL ADI AND ITS LICENSORS BE LIABLE FOR ANY INCIDENTAL, SPECIAL, INDIRECT, OR CONSEQUENTIAL DAMAGES RESULTING FROM CUSTOMER'S POSSESSION OR USE OF THE EVALUATION BOARD, INCLUDING BUT NOT LIMITED TO LOST PROFITS, DELAY COSTS, LABOR COSTS OR LOSS OF GOODWILL. ADI'S TOTAL LIABILITY FROM ANY AND ALL CAUSES SHALL BE LIMITED TO THE AMOUNT OF ONE HUNDRED US DOLLARS (\$100.00). EXPORT. Customer agrees that it will not directly or indirectly export the Evaluation Board to another country, and that it will comply with all applicable United States federal laws and regulations relating to exports. GOVERNING LAW. This Agreement shall be governed by and construed in accordance with the substantive laws of the Commonwealth of Massachusetts (excluding conflict of law rules). Any legal action regarding this Agreement will be heard in the state or federal courts having jurisdiction in Suffolk County, Massachusetts, and Customer hereby submits to the personal jurisdiction and venue of such courts. The United Nations Convention on Contracts for the International Sale of Goods shall not apply to this Agreement and is expressly disclaimed.