



Chipsmall Limited consists of a professional team with an average of over 10 year of expertise in the distribution of electronic components. Based in Hongkong, we have already established firm and mutual-benefit business relationships with customers from,Europe,America and south Asia,supplying obsolete and hard-to-find components to meet their specific needs.

With the principle of "Quality Parts,Customers Priority,Honest Operation,and Considerate Service",our business mainly focus on the distribution of electronic components. Line cards we deal with include Microchip,ALPS,ROHM,Xilinx,Pulse,ON,Everlight and Freescale. Main products comprise IC,Modules,Potentiometer,IC Socket,Relay,Connector.Our parts cover such applications as commercial,industrial, and automotives areas.

We are looking forward to setting up business relationship with you and hope to provide you with the best service and solution. Let us make a better world for our industry!



Contact us

Tel: +86-755-8981 8866 Fax: +86-755-8427 6832

Email & Skype: info@chipsmall.com Web: www.chipsmall.com

Address: A1208, Overseas Decoration Building, #122 Zhenhua RD., Futian, Shenzhen, China



EVAL-AD7997EBZ/AD7998EBZ

FEATURES

- Full-featured evaluation board for the AD7997/AD7998
- PC software for control and measurement of the AD7997/AD7998
- USB interface (cable provided)
- Various linking options

GENERAL DESCRIPTION

This data sheet describes the evaluation board for testing the AD7997/AD7998 devices. These devices are 10-/12-bit, low power, successive approximation analog-to-digital converters (ADCs) with an I²C-compatible interface. The parts operate from a single 2.7 V to 5.5 V power supply and features a 2 μ s conversion time.

The AD7997/AD7998 contain an 8-channel multiplexer and track-and-hold amplifier that can handle input frequencies of up to 11 MHz.

Full details on these devices are provided in the AD7997/AD7998 data sheet available from Analog Devices, Inc., which should be consulted in conjunction with this data sheet.

On-board components for the EVAL-AD7997/AD7998 include two AD5245 digital potentiometers, eight AD8691 operational amplifiers, one AD780 (a pin programmable 2.5 V or 3 V ultra-high precision band gap reference), and one TMP37 precision temperature sensor.

The available link options are described in Table 2 and Table 3.

FUNCTIONAL BLOCK DIAGRAM

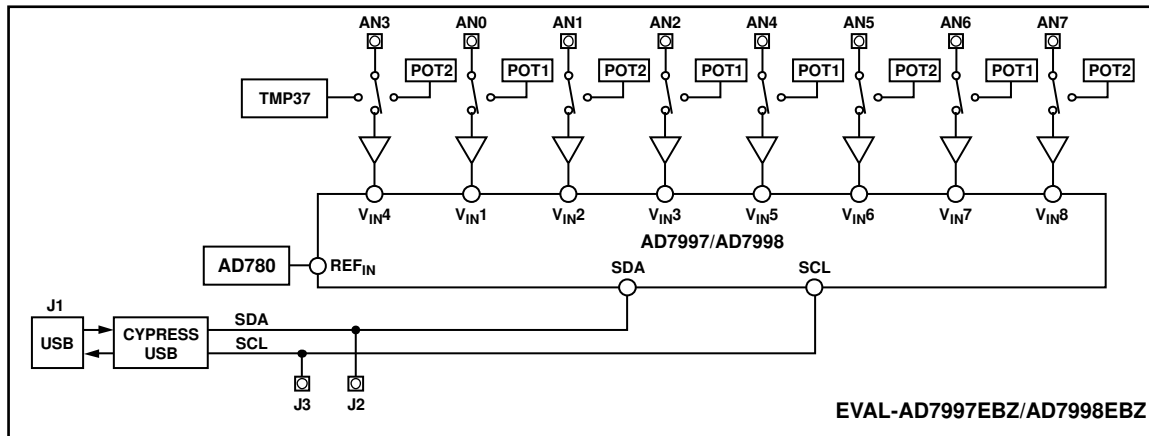

Figure 1.

Rev. 0

Evaluation boards are only intended for device evaluation and not for production purposes. Evaluation boards are supplied "as is" and without warranties of any kind, express, implied, or statutory including, but not limited to, any implied warranty of merchantability or fitness for a particular purpose. No license is granted by implication or otherwise under any patents or other intellectual property by application or use of evaluation boards. Information furnished by Analog Devices is believed to be accurate and reliable. However, no responsibility is assumed by Analog Devices for its use, nor for any infringements of patents or other rights of third parties that may result from its use. Analog Devices reserves the right to change devices or specifications at any time without notice. Trademarks and registered trademarks are the property of their respective owners. Evaluation boards are not authorized to be used in life support devices or systems.

TABLE OF CONTENTS

Features	1	Evaluation Board Software.....	6
General Description	1	Installing the Software	6
Functional Block Diagram	1	Using the Software	6
Revision History	2	Main Window	7
Evaluation Board Hardware.....	3	Evaluation Board Schematics and Artwork.....	8
Initial Setup Conditions	3	Ordering Information.....	12
Power Supplies	3	Bill of Materials.....	12
USB Connector	3	Ordering Guide	12
Sockets	3	ESD Caution.....	12
Links	4		

REVISION HISTORY

11/08—Revision 0: Initial Version

EVALUATION BOARD HARDWARE

INITIAL SETUP CONDITIONS

Care should be taken before applying power and signals to the evaluation board to ensure that all link positions are set as required by the operating mode.

POWER SUPPLIES

The EVAL-AD7997EBZ/AD7998EBZ are powered via the 5 V supply from the USB connector, J1. The 5 V supply can be used to power the [AD7997/AD7998](#) directly through the EMC_FILTER. A regulated voltage from the on-board [ADP3303](#), a high precision, low power, 3.3 V output voltage regulator, can also be used. To select the power supply for the AD7997/AD7998, choose LK7 (see the Links section).

USB CONNECTOR

A standard USB connector, J1, is used to connect the evaluation board to the USB port of a PC. A standard USB connector cable is included with the AD7997/AD7998 evaluation board kits.

Because the USB connector powers the board, there is no need for an external power supply.

Communication between the AD7997/AD7998 evaluation boards and the PC is over the USB interface. The on-board USB controller controls this communication.

SOCKETS

There are 10 input sockets (AN0 through AN7, J2, and J3) relevant to the operation of the AD7997/AD7998 on these evaluation boards. The functions of these sockets are outlined in Table 1.

Table 1. Socket Functions

Socket	Function
AN0 to AN7	Subminiature BNC (SMB) Connector. The analog input signal for V_{IN1} through V_{IN8} of the AD7997/AD7998 is applied to these sockets.
J2	Subminiature BNC (SMB) Connector. This socket is connected to the SDA track on the evaluation board.
J3	Subminiature BNC (SMB) Connector. This socket is connected to the SCL track on the evaluation board.

EVAL-AD7997EBZ/AD7998EBZ

LINKS

Link options can be set to change the configuration of the circuits. Table 2 shows the positions in which all the links are set when the evaluation boards are shipped.

The functions of these link options are summarized in Table 3. The positions of the links can be changed when the evaluation board is connected to the power supply.

Table 2. Initial Link Positions

Link No.	Position	Function
LK1	A	V_{IN1} is connected to digital Potentiometer 1.
LK2	A	Operational amplifier is supplied from J1 (Channel 1).
LK3	A	Operational amplifier is used on Channel 1.
LK4	A	V_{IN2} is connected to digital Potentiometer 2.
LK5	A	Operational amplifier is supplied from J1 (Channel 2).
LK6	A	Operational amplifier is used on Channel 2.
LK7	A	Power source of AD7997/AD7998 is set to 5 V (J1 connector).
LK8	Insert	External reference voltage has a value of 3 V.
LK9	B	Reference input of AD7997/AD7998 is connected to 5 V.
LK10	A	Operational amplifier is used on Channel 3.
LK11	A	Operational amplifier is supplied from J1 (Channel 3).
LK12	A	V_{IN3} is connected to digital Potentiometer 1.
LK13	A	Operational amplifier is used on Channel 4.
LK14	A	Operational amplifier is supplied from J1 (Channel 4).
LK15	A	V_{IN4} is connected to digital Potentiometer 2.
LK16	A	Operational amplifier is used on Channel 5.
LK17	A	Operational amplifier is supplied from J1 (Channel 5).
LK18	A	V_{IN5} is connected to digital Potentiometer 1.
LK19	A	Operational amplifier is used on Channel 6.
LK20	A	Operational amplifier is supplied from J1 (Channel 6).
LK21	A	V_{IN6} is connected to digital Potentiometer 2.
LK22	A	Operational amplifier is used on Channel 7.
LK23	A	Operational amplifier is supplied from J1 (Channel 7).
LK24	A	V_{IN7} is connected to digital Potentiometer 1.
LK25	A	Operational amplifier is used on Channel 8.
LK26	A	Operational amplifier is supplied from J1 (Channel 8).
LK27	A	V_{IN8} is connected to digital Potentiometer 2.

Table 3. Link Options

Link No.	Function
LK1, LK4, LK12, LK18, LK21, LK24, LK27	<p>These links connect the input of V_{IN1} through V_{IN8} to the corresponding AN0 through AN7 socket, where V_{IN1} connects to AN0 and so on. Alternatively, these links connect to an input socket or to a digital potentiometer.</p> <p>In Position A, V_{INX} is connected to the digital potentiometer.</p> <p>In Position B, V_{INX} is connected to the ANx input socket.</p>
LK2, LK5, LK11, LK14, LK17, LK20, LK23, LK26	<p>These links connect the power supply pins of the operational amplifiers to 3.6 V regulated output from the on-board ADP3330 voltage regulators, or to 5 V supply from J1.</p> <p>In Position A, an operational amplifier is supplied from J1.</p> <p>In Position B, an operational amplifier is supplied from the ADP3330.</p>
LK3, LK6, K10, LK13, LK16, LK19, LK22, LK25	<p>These links tie the operational amplifiers to the analog inputs of the AD7997/AD7998.</p> <p>In Position A, the operational amplifier is used.</p> <p>In Position B, the operational amplifier is not used.</p>
LK7	<p>LK7 selects the power source for V_{DD} on the AD7997/AD7998.</p> <p>In Position A, LK7 selects the 5 V supply from the USB connector.</p> <p>In Position B, LK7 selects the 3.3 V regulated output from the on-board ADP3303 voltage regulator.</p>
LK8	<p>LK8 changes the value of the external reference voltage (AD780).</p> <p>If this link is inserted, the reference voltage is 3 V.</p> <p>If this link is not inserted, the reference voltage is 2.5 V.</p>
LK9	<p>LK9 changes the source of the reference voltage for the AD7997/AD7998.</p> <p>In Position A, an external reference source is used (AD780).</p> <p>In Position B, the 5 V supply from J1 is used as a reference voltage.</p>
LK15	<p>LK15 connects the input of V_{IN4} to the AN3 input socket, to a digital potentiometer or to a temperature sensor.</p> <p>In Position A, V_{IN4} is connected to digital Potentiometer 2.</p> <p>In Position B, V_{IN4} is connected to the AN3 input socket.</p> <p>In Position C, V_{IN4} is connected to the temperature sensor.</p>

EVALUATION BOARD SOFTWARE

INSTALLING THE SOFTWARE

The EVAL-AD7997EBZ/AD7998EBZ evaluation board kits include a CD that contains software for controlling and evaluating the functionality of the [AD7997/AD7998](#). To install the software.

1. Start the Windows® operating system and insert the CD.
2. Wait while the installation program automatically begins. This program installs the evaluation software as well as electronic versions of the evaluation board data sheet and the AD7997/AD7998 device data sheet. All literature on the CD is in the Adobe® Systems, Inc., portable document-

ation format (PDF) and requires Acrobat Reader® to be viewed or printed. The user interface on the PC is a dedicated program written especially for the AD7997/AD7998.

3. Connect the evaluation board to the PC when the installation process is finished.

USING THE SOFTWARE

The software that controls the AD7997/AD7998 consists of one window shown in Figure 2. This window, which appears when the software is run, allows you to display and read samples from the evaluation board.



Figure 2. AD7997/AD7998 Evaluation Board Window

MAIN WINDOW

The upper and left portion of the evaluation board window contains a menu bar and controls. The middle-right and bottom-right portions contain digital storage oscilloscopes (DSOs).

Menu Bar

The menu bar (not visible in Figure 2) consists of the **File** and **About** menus.

File Menu

Print front Panel. Prints front panel on active printer.

Save as Picture. Saves front panel as a .jpg file.

Exit. Exits the program.

About Menu

Analog.com. Opens Analog Devices Web page.

Software Version. Displays information about the current version of the software.

Controls

The controls include control buttons, list boxes, and indicators.

Sample. Samples selected channels.

Continuous. Repeats the sampling process.

Limit. Opens window to configure limit registers (Channel 1 only).

Sweep. Starts the sweep function.

LEDs (CH1, CH2, ... CH8). Selects the input channel of the [AD7997/AD7998](#). When more than one channel is selected, the AD7997/AD7998 work in sequence mode.

Load Firmware. Loads the firmware to the Cypress USB device.

Temperature. Enables temperature measurements.

Potentiometer Value Selector (Pot 1/Pot 2). Changes the value of the selected digital potentiometer.

Codes/Volts. Determines whether data is displayed in codes or volts.

Exit. Exits the program.

Alert LED. Indicates if an alert occurred (Channel 1 only).

Ref – VDD – 5V. Selects reference voltage source (power supply voltage or AD780).

2.5V/3V. Changes the value of the external reference voltage (AD780).

Clear Charts. Clears the charts displayed.

Autoscale On/Autoscale Off. Click this button to turn the autoscale feature on or off.

Alert. Shows limits on the upper digital storage oscilloscope.

Channel 1/Channel 2/.../Channel 8. Selects the input channel of the AD7797/AD7798 for the sweep function.

Digital Storage Oscilloscopes

The middle portion of the evaluation board window displays a waveform. When samples are uploaded from the evaluation board, they are displayed here. At the bottom left of the upper DSO are zoom options that allow you to zoom in and out while viewing a sample. To the left of this DSO, information about the sample taken is displayed, such as measured values in codes and in volts.

The lower portion of the main window displays a waveform of the sweep function. At the bottom left of the lower DSO are zoom options that allow you to zoom in and out while viewing a sample. To the right of the DSO, information about the sample taken and the value of each point of sweep function is displayed.

Taking Samples

During the sweep function, 256 samples are taken directly from the digital potentiometer output. The output of the digital potentiometer is incremented by 1, from 0 to 255, and for each increment, the AD7997/AD7998 take a sample. After the measurement, all 256 values are displayed on the digital storage oscilloscope in the lower portion of the main window (see Figure 2).

To instruct the AD7997/AD7998 to take samples click either **Sample** or **Continuous**.

- Click **Sample** to perform one conversion. The result is uploaded and displayed.
- Click **Continuous** to start taking samples. When **Continuous** is selected, other controls can be changed.

EVALUATION BOARD SCHEMATICS AND ARTWORK

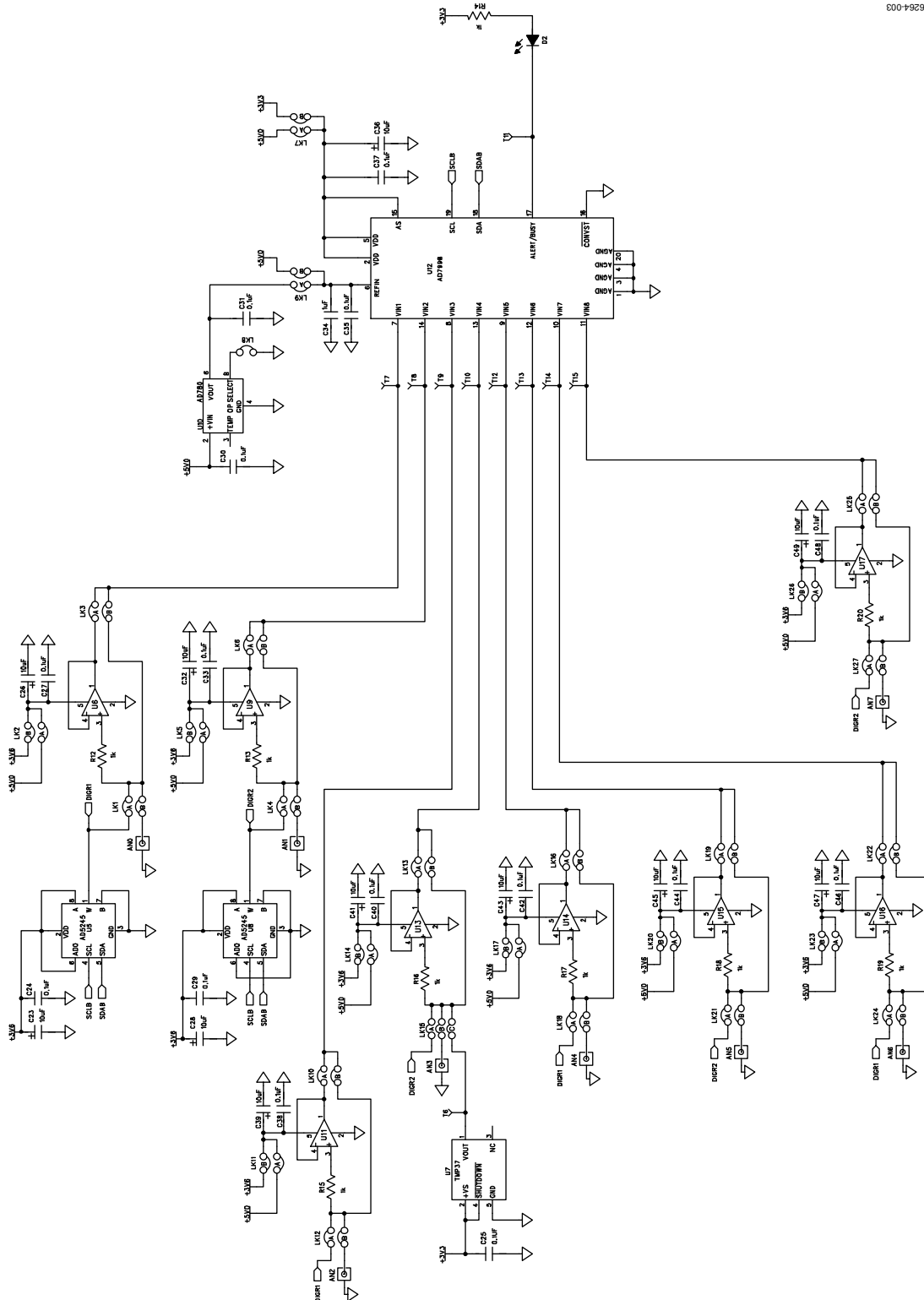

06264-003

Figure 3. AD7997/AD7998 Evaluation Board Schematic 1

USB

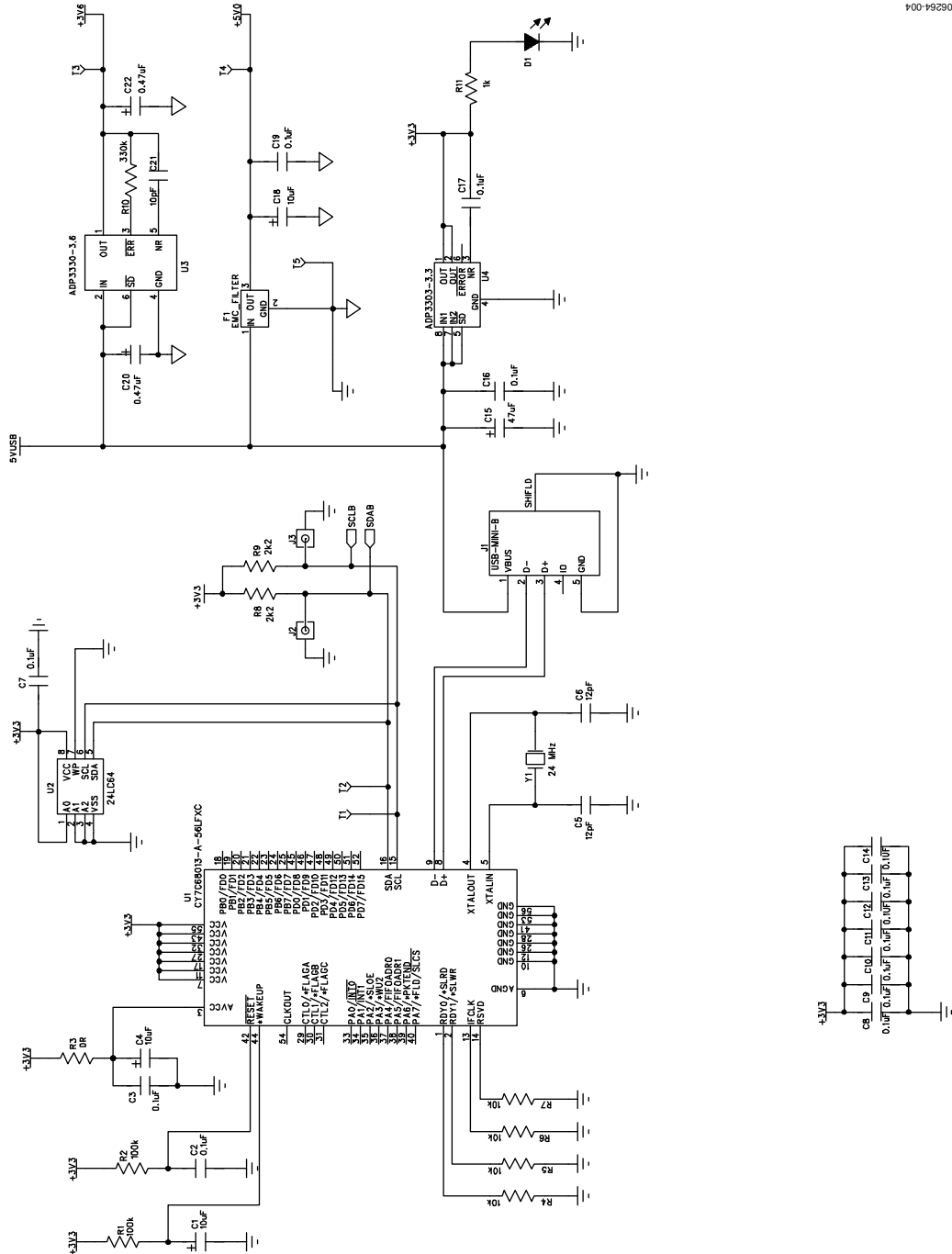

Figure 4. AD7997/AD7998 Evaluation Board Schematic 2

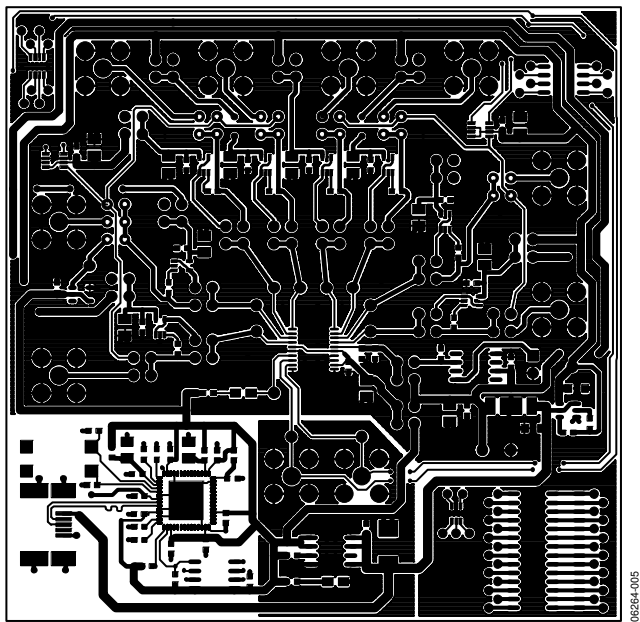

Figure 5. Component Side Artwork

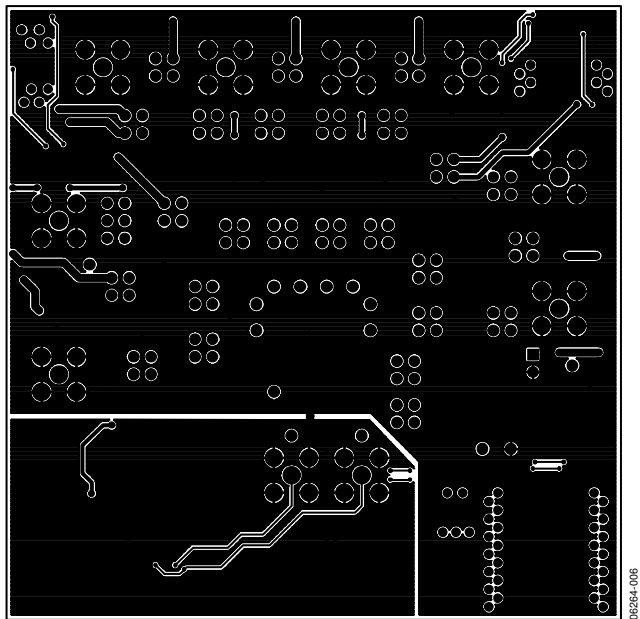

Figure 6. Solder Side Artwork

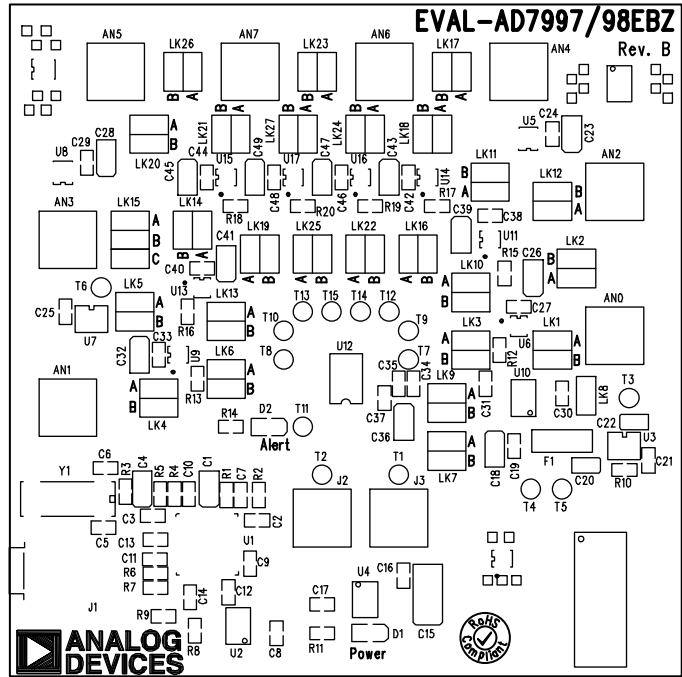

Figure 7. Component Placement Drawing

EVAL-AD7997EBZ/AD7998EBZ

ORDERING INFORMATION

BILL OF MATERIALS

Table 4. Components Listing

Qty.	Reference Designator	Description	Supplier/Number ¹
8	AN0 to AN7	Jack, SMB PCB 50 Ω	FEC 1111349
14	C1, C4, C18, C23, C26, C28, C32, C36, C39, C41, C43, C45, C47, C49	Case A, 10 μF, 10 V capacitor	FEC 197130
28	C2, C3, C7 to C14, C16, C17, C19, C24, C25, C27, C29, C30, C31, C33, C35, C37, C38, C40, C42, C44, C46, C48	0603, 0.1 μF, 16 V capacitor	FEC 9406140
2	C5, C6	0603, 12 pF, 50 V capacitor	FEC 721979
1	C15	Case C, 47 μF, 10 V capacitor	FEC 197324
2	C20, C22	Case A, 0.47 μF, 25 V capacitor	FEC 498828
1	C21	10 pF, 50 V SMD ceramic capacitor	Phycomp FEV721967
1	C34	1 μF, 16 V multilayer ceramic capacitor	FEC 1327680
1	D1	SMD green LED	FEC 5790852
1	D2	SMD red LED	FEC 5790840
1	F1	EMC filter, 1.0 nF 3-terminal capacitor	FEC 9528202
1	J1	USB mini-B SMT connector	Digi-Key WM2499TR-ND
2	J2, J3	Jack, SMB PCB 50 Ω	FEC 1111349
26	LK1 to LK14, LK16 to LK27	4-pin 2 row 36 + 36 way header and red jumper socket	FEC 1022244/FEC 150411
1	LK15	6-pin 2 row 36 + 36 way header and red jumper socket	FEC 148535/FEC 150411
2	R1, R2	0603, 100 kΩ resistor	FEC 9330402
1	R3	0 Ω resistor	FEC 933-1662
4	R4 to R7	0603, 10 kΩ resistor	FEC 9330399
2	R8, R9	0603, 2.2 kΩ resistor	FEC 9330810
1	R10	0603, 330 kΩ resistor	FEC 9331042
10	R11 to R20	0603, 1 kΩ resistor	FEC 9330380
15	T1 to T15	Test point	FEC 8731144
1	U1	Cypress USB microcontroller	Digi-Key 428-1669-ND
1	U2	EEPROM serial 64 kΩ	FEC 9758070
1	U3	High accuracy low dropout regulator	Analog Devices ADP3330ARTZ-3.6
1	U4	High accuracy low dropout regulator	Analog Devices ADP3303ARZ-3.3
2	U5, U8	Digital potentiometer	Analog Devices AD5245BRJZ10
8	U6, U9, U11, U13 to U17	Operational amplifier	Analog Devices AD8691AKSZ-R2
1	U7	Low voltage temperature sensor	Analog Devices TMP37GRTZ
1	U10	Precision band gap voltage reference	Analog Devices AD780ARZ
1	U12	8-channel ADC	Analog Devices AD7998/AD7998BRUZ-0
1	Y1	24 MHz SMD crystal	FEC 9509658

¹ FEC = Farnell Electronics.

ORDERING GUIDE

Model	Description
EVAL-AD7997EBZ ¹	AD7997 Evaluation Board
EVAL-AD7998EBZ ¹	AD7998 Evaluation Board

¹ Z = RoHS Compliant Part.

ESD CAUTION



ESD (electrostatic discharge) sensitive device.
Charged devices and circuit boards can discharge without detection. Although this product features patented or proprietary protection circuitry, damage may occur on devices subjected to high energy ESD. Therefore, proper ESD precautions should be taken to avoid performance degradation or loss of functionality.