



Chipsmall Limited consists of a professional team with an average of over 10 year of expertise in the distribution of electronic components. Based in Hongkong, we have already established firm and mutual-benefit business relationships with customers from,Europe,America and south Asia,supplying obsolete and hard-to-find components to meet their specific needs.

With the principle of "Quality Parts,Customers Priority,Honest Operation,and Considerate Service",our business mainly focus on the distribution of electronic components. Line cards we deal with include Microchip,ALPS,ROHM,Xilinx,Pulse,ON,Everlight and Freescale. Main products comprise IC,Modules,Potentiometer,IC Socket,Relay,Connector.Our parts cover such applications as commercial,industrial, and automotives areas.

We are looking forward to setting up business relationship with you and hope to provide you with the best service and solution. Let us make a better world for our industry!



## Contact us

Tel: +86-755-8981 8866 Fax: +86-755-8427 6832

Email & Skype: info@chipsmall.com Web: www.chipsmall.com

Address: A1208, Overseas Decoration Building, #122 Zhenhua RD., Futian, Shenzhen, China



## Evaluating the **ADE9000** High Performance, Multiphase Energy, Power Quality Monitoring IC

### FEATURES

Full featured evaluation board for the **ADE9000**  
 PC control in conjunction with the **EVAL-SDP-CB1Z** system  
 demonstration platform (SDP)  
 PC software for control and data analysis (time and  
 frequency domain)  
 Standalone capability

### EVALUATION KIT CONTENTS

**EVAL-ADE9000EBZ** evaluation board

### ADDITIONAL EQUIPMENT NEEDED

**EVAL-SDP-CB1Z** (must be ordered separately)  
 Includes a mini USB cable  
 Current transformers or Rogowski coils for 3-phase current  
 channels and the neutral channel  
 Precision current and voltage signal source  
 PC running Windows XP SP2, Windows Vista, or Windows 7  
 with USB 2.0 port

### DOCUMENTS NEEDED

**ADE9000** data sheet  
**EVAL-ADE9000EBZ** user guide

### SOFTWARE NEEDED

**EVAL-ADE9000EBZ** evaluation software

### ONLINE RESOURCES

Design and integration files  
 Schematics, layout files, and bill of materials

### GENERAL DESCRIPTION

The **EVAL-ADE9000EBZ** evaluation board allows the performance of the **ADE9000** energy monitoring IC to be evaluated in a context very similar to an actual power quality monitor. The kit requires purchasing a second board: the controller board for the system demonstration platform (**EVAL-SDP-CB1Z**) and current sensors. The **ADE9000** evaluation kit includes evaluation software, written in LabVIEW®, which provides access to the registers and features of the device using a PC interface.

Consult the **ADE9000** data sheet in conjunction with this user guide when using the evaluation board.

### TYPICAL EVALUATION BOARD SETUP

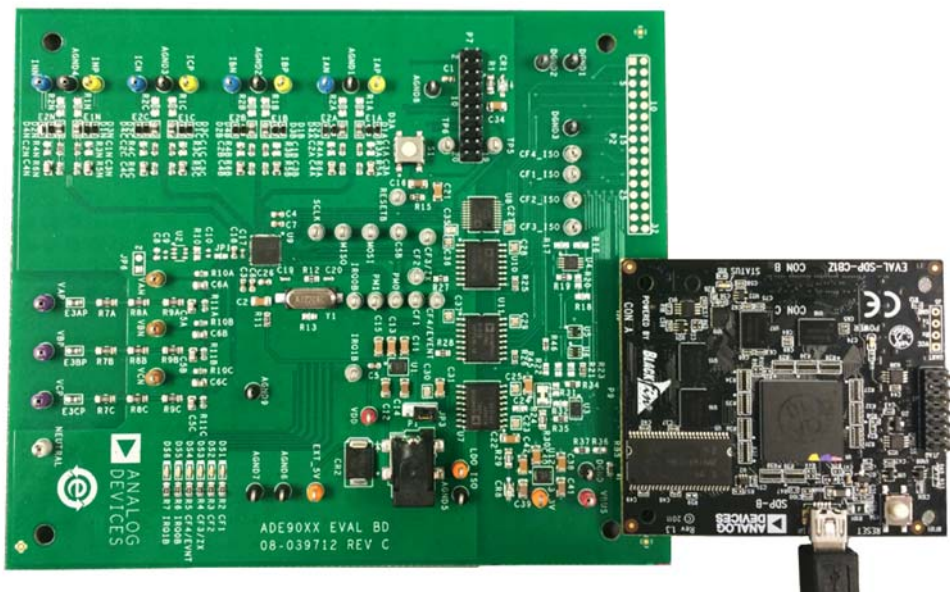

Figure 1. **EVAL-ADE9000EBZ** (Left) Connected to **EVAL-SDP-CB1Z** SDP Interface Board (Right)

15326-001

**TABLE OF CONTENTS**

Features .....	1	Using the Evaluation Board with Another Microcontroller.....	6
Evaluation Kit Contents.....	1	Evaluation Board Software.....	7
Additional Equipment Needed .....	1	Installing the Drivers .....	7
Documents Needed.....	1	Installing and Uninstalling the EVAL-ADE9000EBZ	
Software Needed .....	1	Software .....	7
Online Resources .....	1	Main Window .....	7
General Description .....	1	Evaluation Software Functions .....	9
Typical Evaluation Board Setup.....	1	Read/Write Registers Option.....	9
Revision History .....	2	Powers and Energies .....	13
Evaluation Kit Connection Diagram .....	3	RMS Window.....	16
Evaluation Board Hardware.....	4	Waveform Buffer Window .....	17
Overview.....	4	Angle Window.....	18
Powering Up the Evaluation Boards .....	4	Quick Startup Window.....	19
Analog Inputs.....	4	Interrupts Window.....	20
Current Sense Inputs: IAP, IAN, IBP, IBN, ICP, ICN, INP, and		Power Quality Window .....	21
INN Test Pins .....	4	Troubleshooting.....	23
Using Current Sense Transformers .....	4	Evaluation Board Schematics and Artwork.....	24
Using Rogowski Coils .....	5	Ordering Information.....	29
Phase Voltage Sense Inputs: VAP and VAN, VBP and VBN,		Bill of Materials.....	29
and VCP and VCN Test Pins .....	5		
Setting Up the Evaluation Board as an Energy Meter .....	6		

**REVISION HISTORY**

**1/2017—Revision 0: Initial Version**

# EVALUATION BOARD CONNECTION DIAGRAM

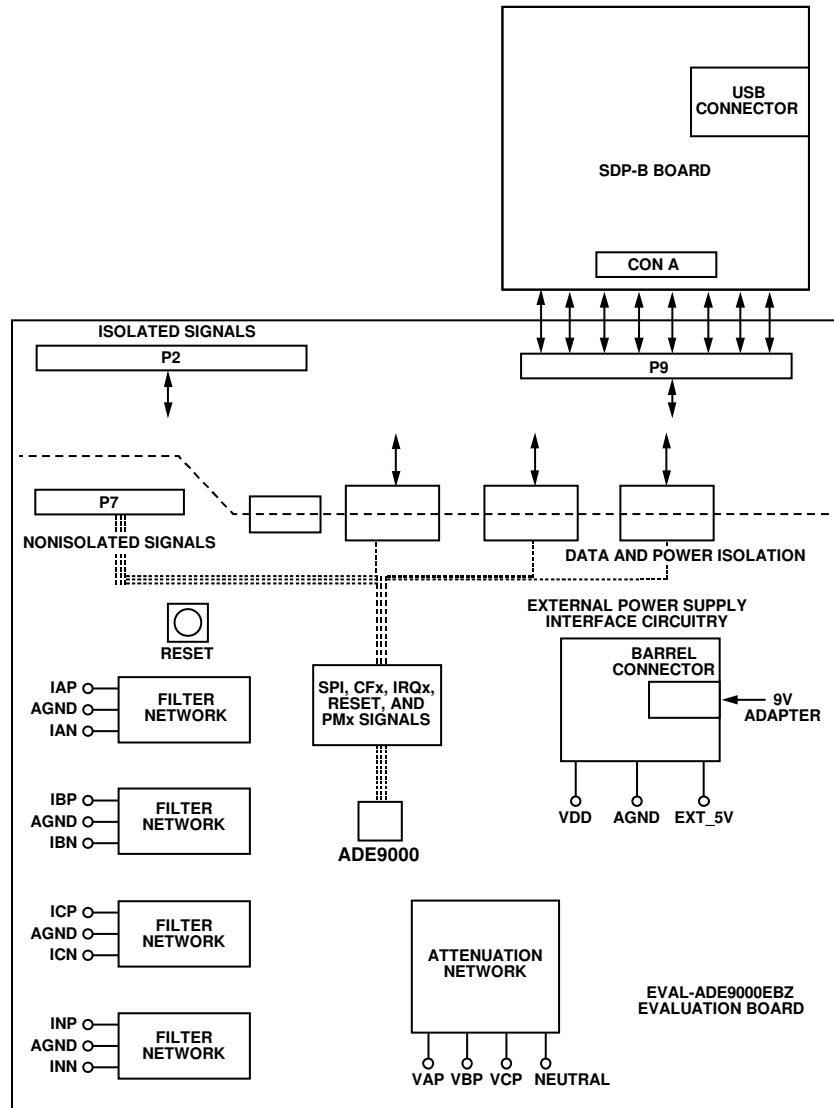

Figure 2. Evaluation Board Connection Diagram

15326-002

## EVALUATION BOARD HARDWARE

### OVERVIEW

The EVAL-ADE9000EBZ and the SDP-B (also referred to as the EVAL-SDP-CB1Z or the Blackfin® SDP board) boards are both required to evaluate the ADE9000.

When ordering the EVAL-ADE9000EBZ evaluation board, order the EVAL-SDP-CB1Z; the evaluation kit and the SDP-B board are purchased and packaged separately, but must be used together.

The EVAL-ADE9000EBZ board is connected to the SDP-B board using the 120-pin connector, P9, on the EVAL-ADE9000EBZ evaluation board. The SDP-B board consists of an ADSP-BF527 microcontroller that handles all the communications from the PC to the ADE9000 device that populates the evaluation board.

### POWERING UP THE EVALUATION BOARDS

The ADE9000 can be powered through the USB of the SDP-B board or an external power supply.

Power the ADE9000 externally by connecting a 3.3 V supply to the VDD test point, or a 5 V to 16 V dc supply to the EXT\_5V test point or barrel jack. When using an external supply, connect Pin 1 and Pin 2 at J3. Connect Pin 2 and Pin 3 to power the ADE9000 with internal isolated power from the SDP-B board.

### ANALOG INPUTS

Current and voltage signals are connected at the test pins placed on the evaluation board. All analog input signals are filtered using the on-board antialiasing filters before the signals are connected to the ADE9000. The components used on the board are the recommended values to be used with the ADE9000.

### CURRENT SENSE INPUTS: IAP, IAN, IBP, IBN, ICP, ICN, INP, AND INN TEST PINS

Figure 3 shows the structure used for the Phase A current channel in the evaluation board. The same signal path is used for the other current channels. Therefore, the explanation in this section applies to other current channels on the evaluation board, such as Phase B, Phase C, and the neutral phase.

E1A and E2A are ferrite beads that filter any high frequency noise present on the wires. Immediately following the ferrite beads, there are four protection diodes per current channel used for overcurrent protection. The antialiasing filter network appears after the protection network.

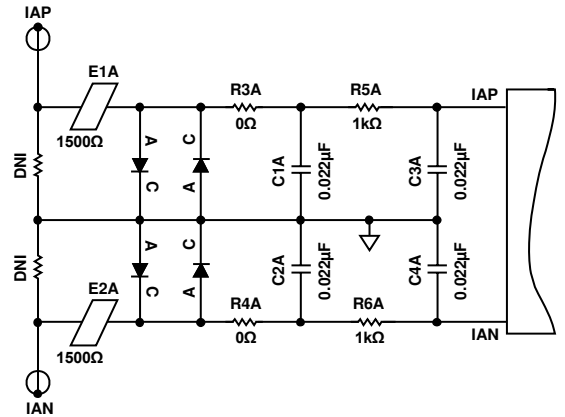

Figure 3. Phase A Current Input Structure on the Evaluation Board

### USING CURRENT SENSE TRANSFORMERS

Figure 4 shows an example of a current transformer sensor configuration. When using current sense transformers, populate the R1A and R2A burden resistors according to the full-scale current and the current transformer (CT) turns ratio of the application. The CT turns ratio and the burden resistor values must be chosen such that the IAP pin to AGND pin and IAN pin to AGND pin potentials do not exceed ±0.5 V peak. The C1A and C2A capacitors are not populated when the current transformer is used. An example burden resistor calculation, where the maximum expected current at current transformer primary is 50 A rms, the CT turns ratio is 3000:1, and the secondary current at 50 A is as follows,

$$I_{SECONDARY} = \frac{50}{3000} = 16.66 \text{ mA}$$

To allow headroom, the input signal into the current channel analog-to-digital converter (ADC) at maximum current is set at half of full scale. Because the full-scale differential input is ±0.707 V rms, the total burden resistor,  $R_B$ , can be calculated as

$$R_B = \left( \frac{0.707}{2} \times \frac{1}{16.66 \text{ mA}} \right) = 21.2 \text{ } \Omega$$

Because the total burden resistor is split to have a differential configuration,

$$R1A = R2A = \frac{R_B}{2} = \frac{21.2}{2} = 10.6 \text{ } \Omega$$

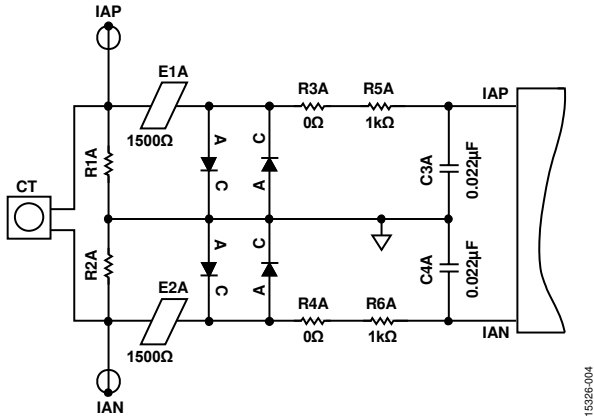

Figure 4. Example of a Current Transformer Connection

**USING ROGOWSKI COILS**

Figure 5 shows an example of a configuration using a Rogowski coil current sensor. The R1A and R2A burden resistors are not used in this configuration, and are therefore removed from the board. Because Rogowski coil sensors have a gain that increases with frequency (20 dB/decade), the high frequency components of the current signal are amplified by a larger factor. Therefore, two stages of resistor capacitor (RC) filtering are required to attenuate the high frequency components and to avoid aliasing. The R3A and R4A resistors must be 100 Ω and are used in conjunction with the 22 nF C1A and C2A capacitors to form a low-pass filter with a cutoff frequency of 72 kHz. This first stage is followed by the 1 kΩ/22 nF RC filter combination that provides a cutoff frequency of 7.2 kHz. The Rogowski coil must be chosen such that the IAP to AGND and IAN to AGND potentials do not exceed ±0.5 V peak.

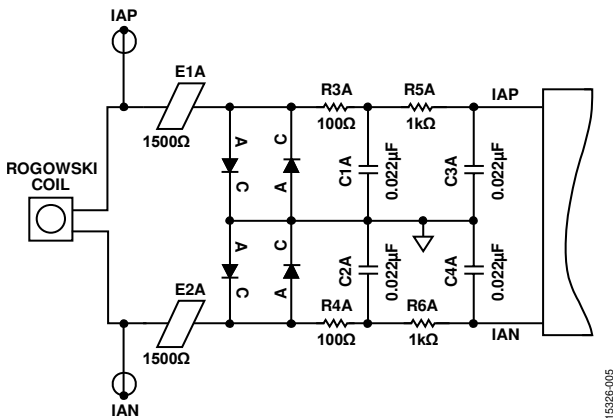

Figure 5. Example of a Rogowski Coil Connection

**PHASE VOLTAGE SENSE INPUTS: VAP AND VAN, VBP AND VBN, AND VCP AND VCN TEST PINS**

Figure 6 shows the Phase A voltage channel signal path on the evaluation board. The same signal path is also replicated on the Phase B and Phase C channels; therefore, the description in this section applies to the Phase B and Phase C channels.

E3AP is a ferrite bead that filters any high frequency noise present on the wires. There are three 330 kΩ resistors connected in series, forming an attenuation network with a 1 kΩ resistor, R11A. This setup provides an attenuation ratio of 990:1. The R11A and C5A RC combination and the R10A and C6A RC combination have the same cutoff frequency as that of the RC filters used on the current channels. This matching is essential to avoid large phase errors between the voltage and current signals. If a different attenuation ratio is preferred, replace the R7A, R8A, and R9A resistors with alternate resistors. The resistors must be chosen such that the maximum signal at the VAP pin is ±0.5 V peak with respect to the AGND pin. The Phase A line is connected to the VAP test point and the neutral line (in the case of the 3-phase, 4-wire wye configuration) is connected to the NEUTRAL test point. The NEUTRAL test point is tied to the AGND potential of the ADE9000.

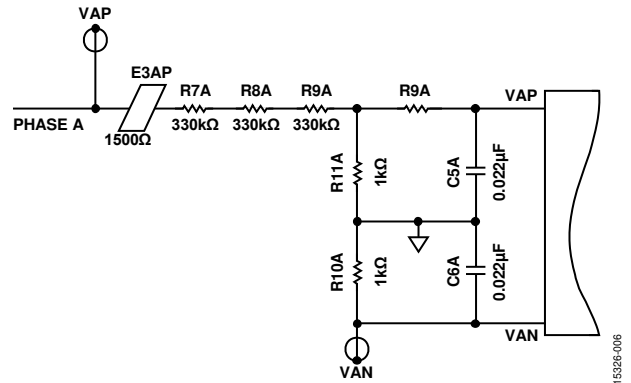

Figure 6. Phase A Voltage Input Structure on the Evaluation Board

**SETTING UP THE EVALUATION BOARD AS AN ENERGY METER**

Figure 7 shows a typical setup for the EVAL-ADE9000EBZ evaluation board. In this example, an energy meter for a 3-phase, 4-wire, wye distribution system is shown. Current transformers sense the phase currents and are connected as shown in Figure 7. The line voltages are connected directly to the board as shown.

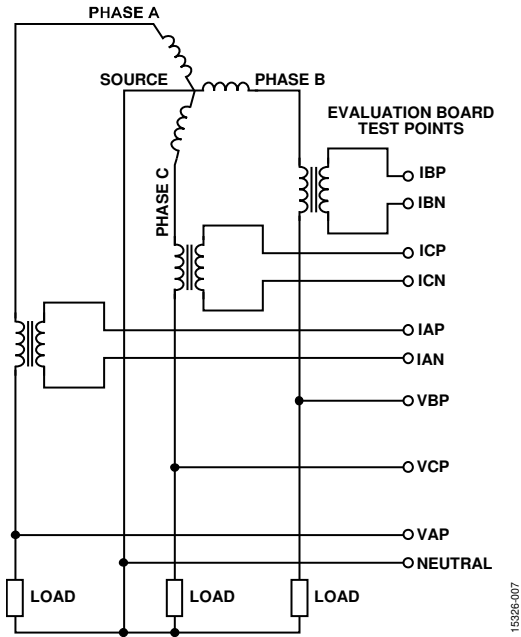

Figure 7. Typical Setup for the EVAL-ADE9000EBZ for 3-Phase, 4-Wire, Wye Distribution System

Figure 8 shows a typical setup for the EVAL-ADE9000EBZ evaluation board as an energy meter for a 3-phase, 3-wire, delta distribution system. The Phase B voltage is considered a reference and therefore is tied to the NEUTRAL test point on the evaluation board.

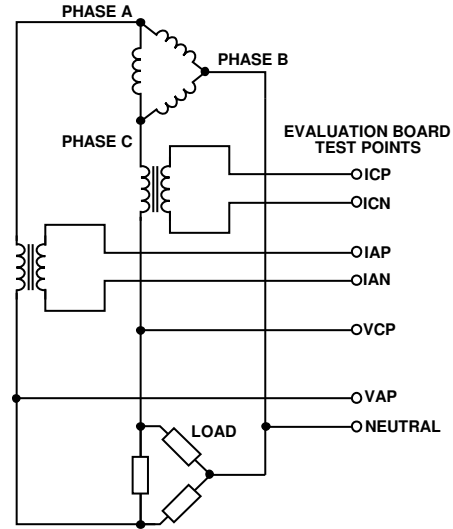

Figure 8. Typical Setup for the EVAL-ADE9000EBZ for a 3-Phase, 3-Wire, Delta Distribution System

**USING THE EVALUATION BOARD WITH ANOTHER MICROCONTROLLER**

It is possible to manage the ADE9000 evaluation board with a different microcontroller mounted on another board. The evaluation board can be connected to this second board through the P2 connector. The SDP-B board in this case is unused and not connected. If nonisolated signals are to be used with the external microcontroller, the P7 connector can be used. In this case, the U7, U8, U10, and U11 isolators must be removed from the EVAL-ADE9000EBZ evaluation board. Note that the P2 and P9 connectors have isolated signals, whereas the P7 connector is nonisolated. It is necessary to have isolation on the host side if signals from the P7 connector are used.

## EVALUATION BOARD SOFTWARE

The **EVAL-ADE9000EBZ** is supported by Windows®-based software that allows the user to access all the functionality of the **ADE9000**. The software communicates with the **SDP-B** board using the USB. The **SDP-B** microcontroller communicates with the **ADE9000** placed on the evaluation board to process the requests sent from the PC.

### INSTALLING THE DRIVERS

Make sure to have administrator privileges to install and run the evaluation software. Disconnect the **SDP-B** board.

1. Install SDPDriversNET.exe located in the **SDP Drivers\** folder. This installs the SDP drivers and the .NET framework required to install LabVIEW run-time engine. .NET 3.5 or higher is required to install LabVIEW run-time engine.
2. Connect the USB cable from the PC to the **SDP-B** board. Windows detects the device and locates the correct driver automatically.

### INSTALLING AND UNINSTALLING THE EVAL-ADE9000EBZ SOFTWARE

The **ADE9000** evaluation software is supplied with the evaluation software package. It contains an installer to install the **EVAL-ADE9000EBZ** evaluation software. The program to be installed is a LabVIEW-based program that runs on the PC.

When running the software on a PC that does not have LabVIEW 2014 for the first time, run the installer. The installer installs a LabVIEW run-time engine that enables the PC to open the evaluation software executable without any issues. This installer is available in the **LabVIEW\InstallationFiles** folder. If LabVIEW 2014 is available on the PC, the executable can be directly opened from the **Executable\** folder.

To install and launch the **EVAL-ADE9000EBZ** evaluation software, use the following procedure:

1. Double click **InstallationFiles\setup.exe** to launch the setup program that automatically installs all the software components, including the uninstall program, and creates the required directories.
2. To launch the software, click **Start, All Programs, ADE9000** and click **ADE9000\_Evaluation\_Software**. When the software runs for the first time, right-click **ADE9000\_Evaluation\_Software.exe** and select **run as the administrator**.

Both the **EVAL-ADE9000EBZ** evaluation software program and the run-time engine are uninstalled using the **Add/Remove Programs** option in the Control Panel.

Before installing a new version of the **EVAL-ADE9000EBZ** evaluation software, use the following procedure:

1. Uninstall the previous version of the evaluation software.
2. Select the add/remove programs option in the Windows Control Panel.
3. Select the program to uninstall and click **Add/Remove**.

### MAIN WINDOW

When the software executable opens, the main window of the evaluation software appears, as shown in Figure 9. When opened for the first time, the software searches for two files: the register file, **ADE9000\_reg\_map.bin**, and the SDP microcontroller code file, **ADE9000.ldr**. These files can be found in the **\Executable\data** folder. After manually choosing the location of these files the first time, the **ADE9000coms.ini** file is updated with their file paths. This update allows the software to find the files correctly during the next run.

The software recognizes the device on the evaluation board, (the **ADE9000**) and displays the device features in the **IC being evaluated:** box of the window. The SDP code version and the version register value of the IC are displayed in their corresponding boxes in the window.

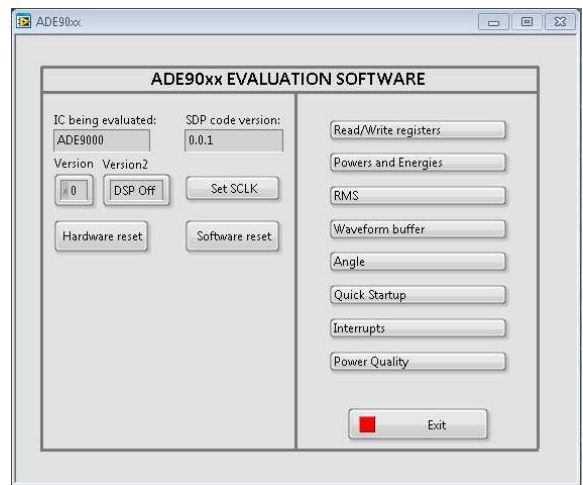

Figure 9. Main Window of the Evaluation Software

Three different operations can be performed using the options present in the left pane of the main window (see Figure 9). These operations are enacted using the following buttons:

1. **Set SCLK.** Click this option to open the **Select SPI Frequency** window, as shown in Figure 10. Set the serial peripheral interface (SPI) clock frequency for communication between the [ADE9000](#) and the [SDP-B](#) board using this window. Enter the intended SCLK frequency value on the SCLK control and click **Check if Valid**. The **Check if Valid** option rounds off the clock frequency to the closest setting that is possible in the [SDP-B](#) board. Finally, click **Set SCLK** to set the SCLK frequency in the [SDP-B](#) board. The window closes automatically. The default SPI clock rate is 10 MHz.
2. **Software reset.** Click this option to perform a software reset on the [ADE9000](#). A dialog box appears confirming the completion of the reset operation.

3. **Hardware reset.** Click this option to perform a hardware reset on the [ADE9000](#). A dialog box appears confirming the completion of the reset operation.

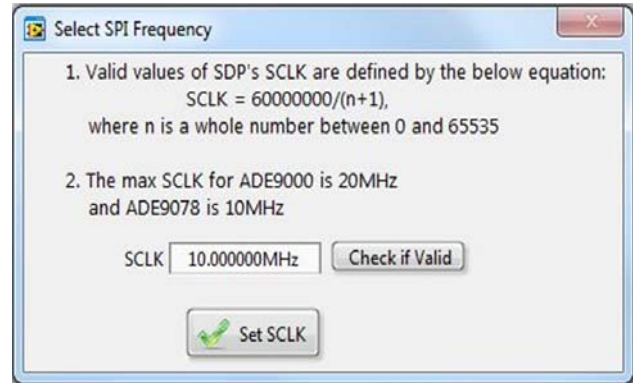

Figure 10. **Set SCLK** Option on the [SDP-B](#) Board

## EVALUATION SOFTWARE FUNCTIONS

The right pane of the main window (see Figure 9) consists of eight options, each of which can be used to evaluate a particular functionality of the ADE9000. The functionalities that can be evaluated are represented by the following options:

- Read/Write registers
- Powers and Energies
- RMS
- Waveform buffer
- Angle
- Quick Startup
- Interrupts
- Power Quality

Clicking any of these eight options opens a corresponding window. To close any of these windows, the same option must be clicked again in the main window. Multiple windows can be left open on the monitor to evaluate different features at the same time.

### READ/WRITE REGISTERS OPTION

The first option in the right pane of the main window is **Read/Write registers**. Click this option to open the **Read/Write registers** window, as shown in Figure 11. There are four tabs available within this window: **Single access**, **Sequential access**, **All register access**, and **Read on Interrupt**.

Each tab helps perform read/write operations to the ADE9000 at different capacities.

#### Single Access Tab

The **Single access** tab contains a **Name** selection box. Click the down arrow in the selection box to open a list of all the registers within ADE9000. Any of the registers can be selected for communication purposes. After the registers are selected, the **Address** box and **Length** box are updated on the screen. Alternatively, the address of the register can be written first, which updates the register name and the length fields. The individual bit fields within the register can be accessed via the **Bitfield** box. Data can be written to and read from the IC using the **Write** and **Read** options. The white boxes in the window denote the description of the register and the corresponding bit fields. Figure 11 shows the window when the **Single access** tab is selected.

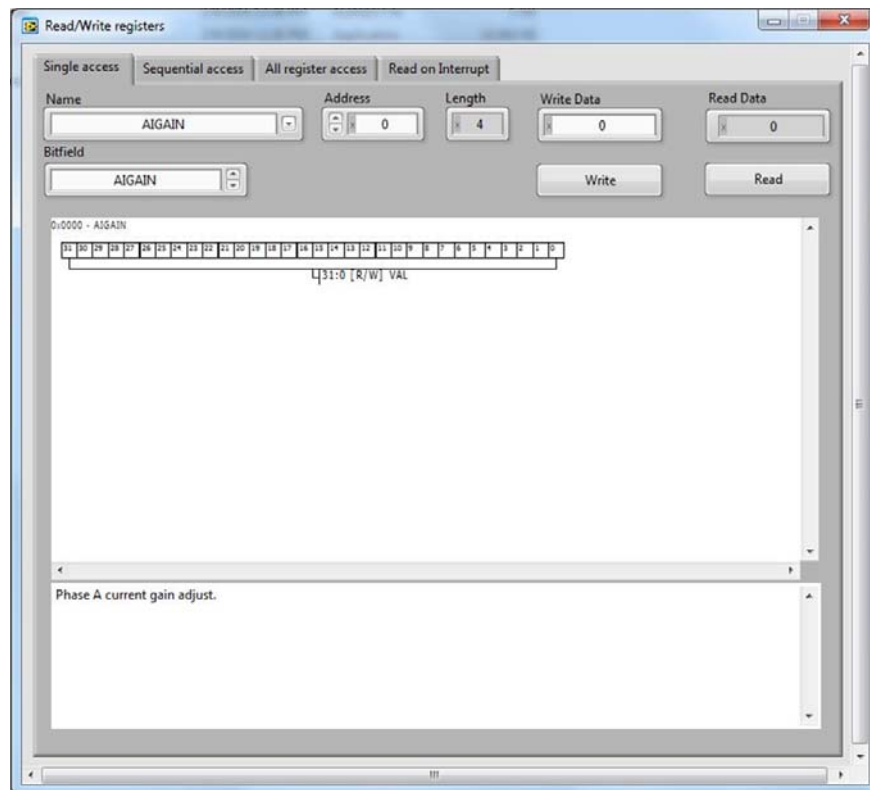

Figure 11. Single access Tab in the Read/Write registers Window

**Sequential Access Tab**

The **Sequential access** tab allows the user to perform read or write operations on four different registers, in a particular order. The **Enable** checkboxes at the beginning of each of the steps

(Step 1 through Step 4) can be selected to enable that particular step. When all the required settings are entered, click **Execute Sequence** to perform the operations in sequence. Figure 12 shows the window when the **Sequential access** tab is selected.

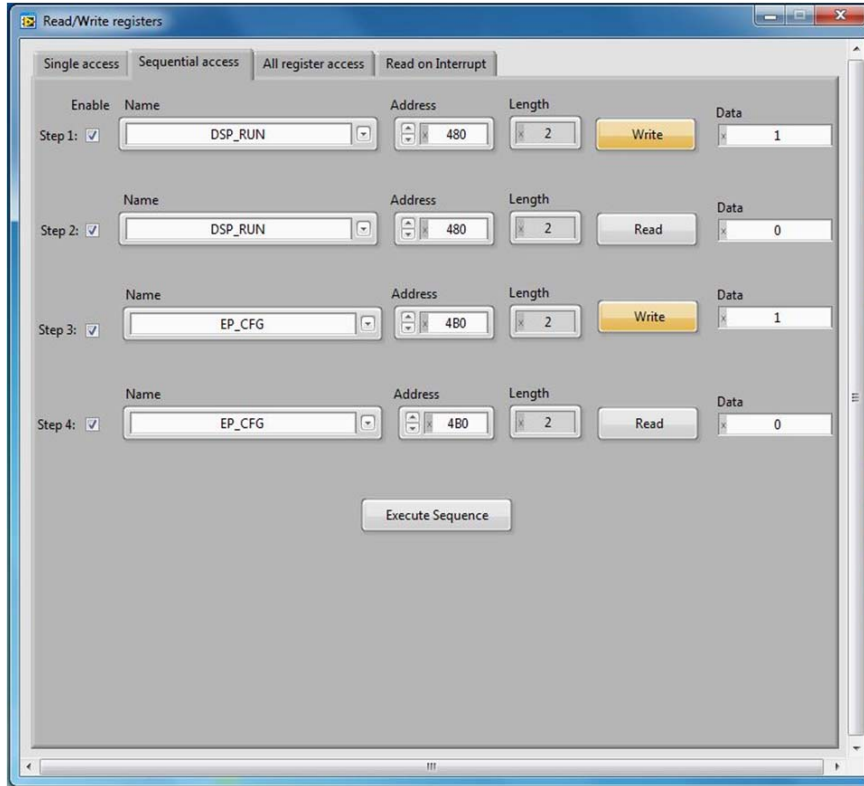

Figure 12. **Sequential access** Tab in the **Read/Write registers** Window

15326-013

**All Register Access Tab**

The **All register access** tab allows the user to read from all the registers on the device and to write all writable registers by clicking a single option. Click **Read and display all registers** to read the registers and output the results to the **Register values** table. Enter the file path for saving the register values and click **Save data to file** to generate a text file with all the register values. Any notes for reference can be added to the file using the **Notes** field. The saved text file can also be edited and used to write back to

the registers. When attempting to write back to the registers, edit the hexadecimal register value in the text file and specify the file path next to the **Read from file and update display** option (perform this action before clicking this option). Click **Read from file and update display** to update the table in the window with the values from the file. At this point, clicking the **Write register values from display** option writes to all the writable registers within the **ADE9000**. Figure 13 shows the window with the **All register access** tab selected.

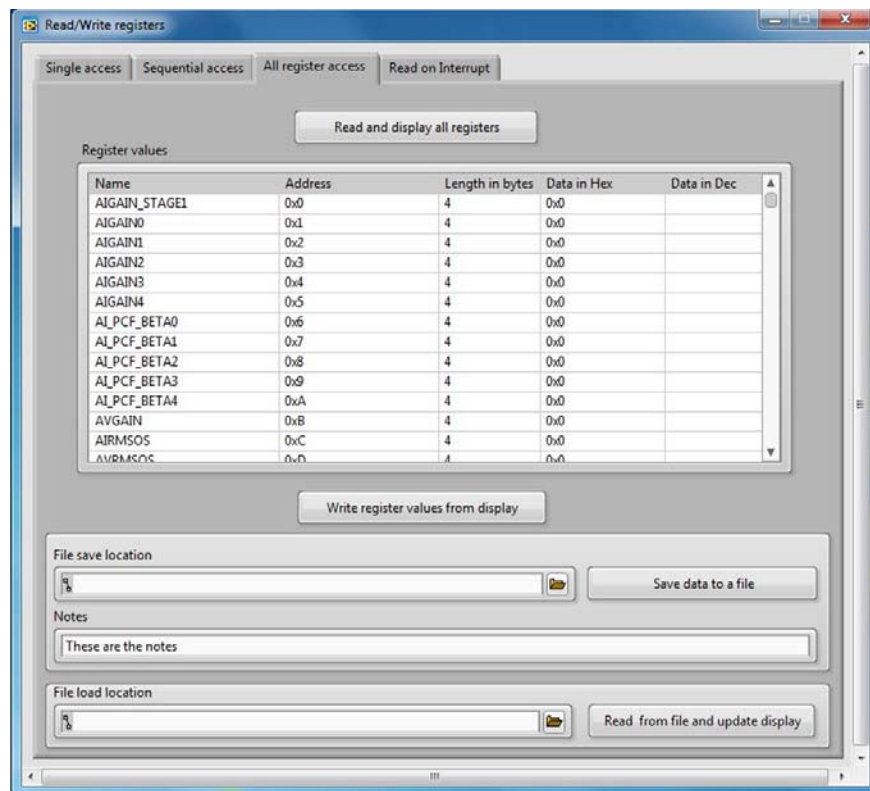

Figure 13. All register access Tab in the Read/Write registers Window

15026-014

**Read on Interrupt Tab**

The **Read on Interrupt** tab allows the user to read any particular register on any particular interrupt event. Examples of cases where using this tab may be useful are as follows:

- Reading the AVRMS register result on each DREADY interrupt.
- Reading the AWATTHR\_HI register result at every EGYRDY interrupt.

The register and the interrupt can be selected from their respective boxes in the window. The number of desired register reads is entered in the **No. of interrupts** field. Click **Read on interrupts** at this point to perform the read operation. The results are available in the **Read-back values** table. Click **Save data to a file** to save the readback values. Figure 14 shows the window when the **Read on Interrupt** tab is selected.

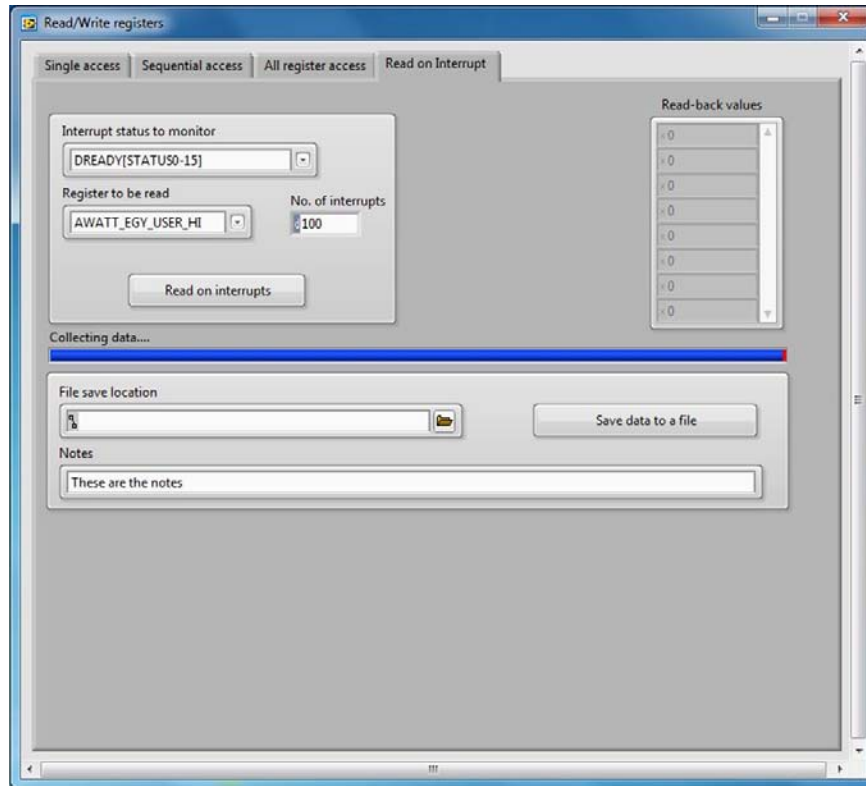

Figure 14. **Read on Interrupt** Tab in the **Read/Write registers** Window

15326-015

**POWERS AND ENERGIES**

The next functionality available in the evaluation software is powers and energies, located in the **Powers and Energies** window. This window contains the **Powers**, **Energies**, and **CF** tabs.

**Powers Tab**

The **Powers** tab allows the user to read from all the instantaneous powers and accumulated powers available in the [ADE9000](#).

Before evaluating the accumulated powers, it is recommended to set the **Power update rate (ms)** field and click **Set**. This action writes to the PWR\_TIME register accordingly. Figure 15 shows the window when the **Powers** tab is selected in the evaluation software. The signal path for the independent current and voltage channels is found in the RMS Window section. Note that the **update continuously** option must be disabled before writing a value to any register.

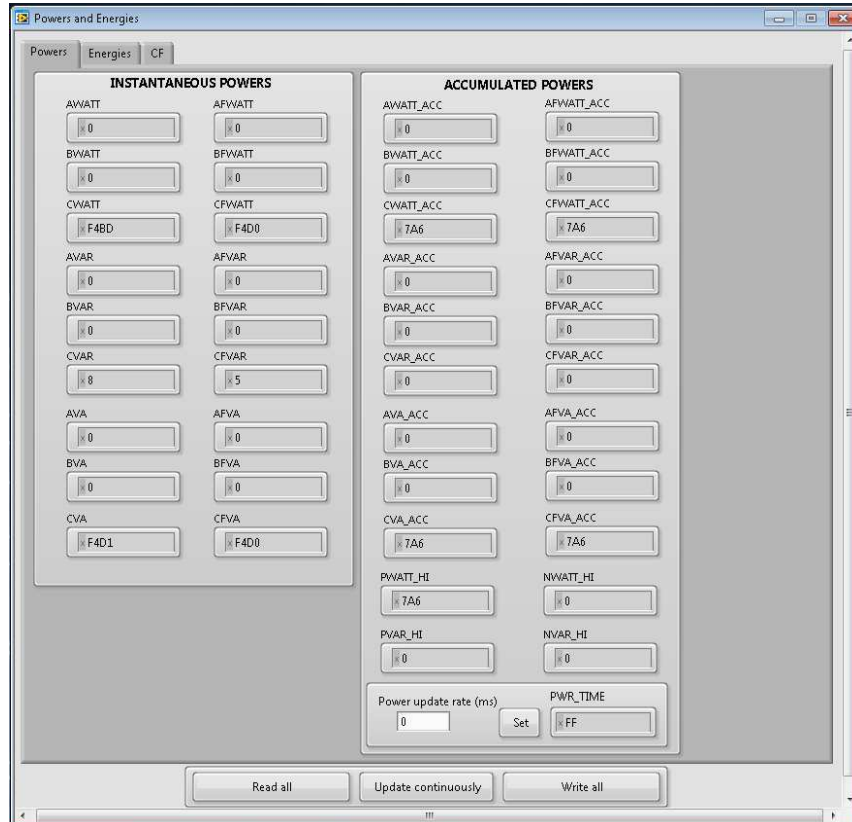

Figure 15. Powers Tab in the Powers and Energies Window

**Energies Tab**

The **Energies** tab allows the user to set the EP\_CFG register and the EGY\_TIME register correctly and to read the energy results from the ADE9000. Figure 16 shows the **Energies** tab. In the **ENERGY SETTINGS** pane, there are different options available for the user, such as the **Accumulation Setting**, which, when turned on, can be further specified using the **Sample-based** or **Half-Line Cycle** options. Select the **Enable accumulation** box to

overwrite the user energy register at every EGYRDY bit interval (EGY\_LD\_ACCUM = 1). After all inputs are populated, click **Set** to write to the registers appropriately. Then, select the **Enable energy/power calculations** box and click **Set**. The **ENERGY** pane displays the energy results. Note that the **Update continuously** option must be disabled before writing a value to any register.

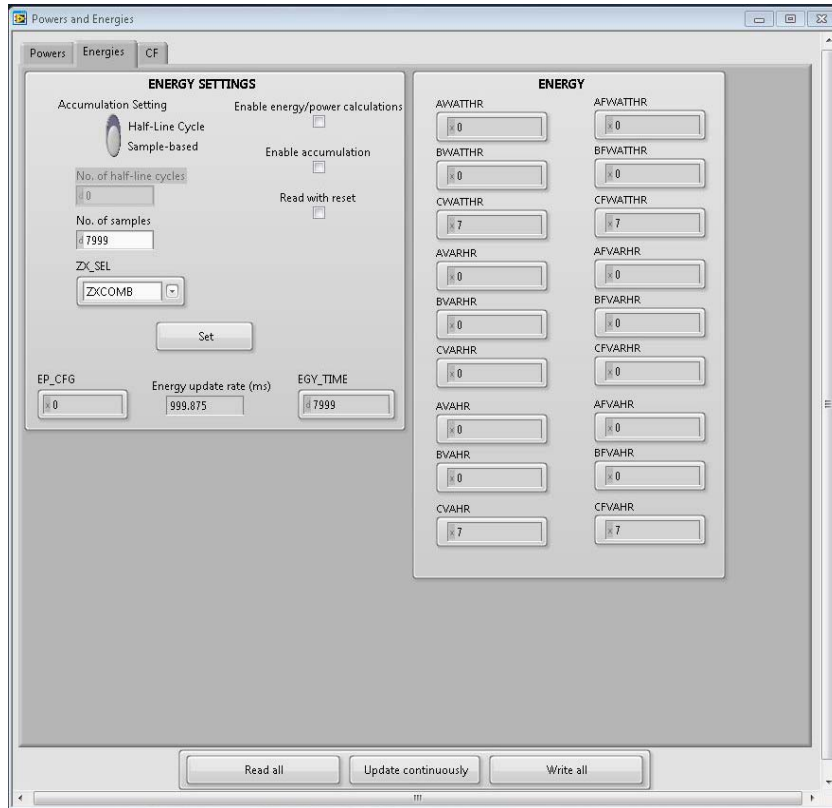

Figure 16. **Energies** Tab in the **Powers and Energies** Window

**CF Tab**

The CF tab allows the user to configure the CF1 to CF4 pins of the ADE9000. There is a wide range of configurability available in the ADE9000 with respect to the functionality of the CF1 to CF4 pins. Some of the major settings that affect the CF1 to CF4 pins results include the phases enabled in each CF1 to CF4 pin, the type of energy represented, and the CF1DEN to CF4DEN register values. These settings can be set using the CF tab, as shown in

Figure 17. There are additional functionalities muxed onto the CF3 and CF4 pins, which can also be controlled using this tab. Common threshold settings such as WTHR, VARTHR, and VATHR can also be set in the COMMON SETTINGS pane of the CF tab. The CF1 to CF4 low pulse widths can be fixed at a particular value by enabling the corresponding check boxes for each of the CF1 to CF4 pins and setting a value for the CF\_LTMR[18:0] bit field to execute this pulse width setting.

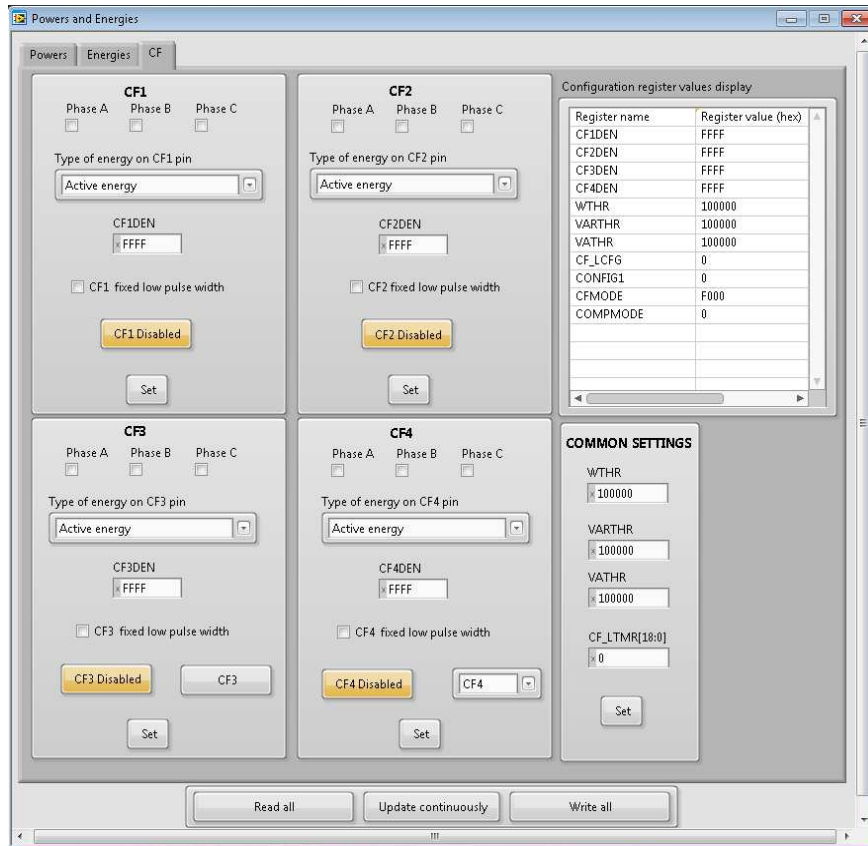

Figure 17. CF Tab in the Powers and Energies Window

**RMS WINDOW**

The RMS window allows the user to visualize the datapath inside the ADE9000, configure the high-pass filter, integrator, programmable gain amplifier (PGA) gain levels, ADC\_REDIRECT register values, VCONSEL and ICONSEL settings, and view the results. To perform the configuration changes, enter the changes to the respective boxes in the window and click **Write**, located in the bottom right corner of the signal path, as shown in Figure 19. The different gain and offset registers can also be accessed via the tabs within this window.

There are several tabs within the **RMS** window. The first tab is the **Continuous monitor** tab, shown in Figure 18. The current and voltage rms results are shown separately on the screen.

There are individual tabs present for each of the voltage and current channels. Under each of these tabs, there are multiple subtabs. The **IA** and **VA** tabs are shown in Figure 19 and Figure 20, respectively. The **VB** and **VC** datapaths are very similar to the **VA** datapath; the **IB** and **IC** datapaths are very similar to the **IA** datapath. To enable or disable the **Multi-point Gain and Phase** calibration, click **Disabled**. The state of this option controls the multi-point gain and phase register accessibility.

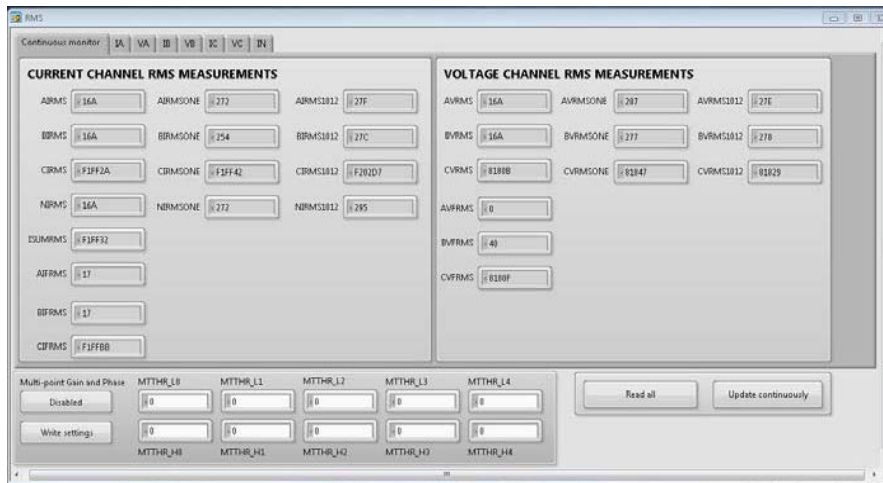

Figure 18. Continuous monitor Tab in the RMS Window

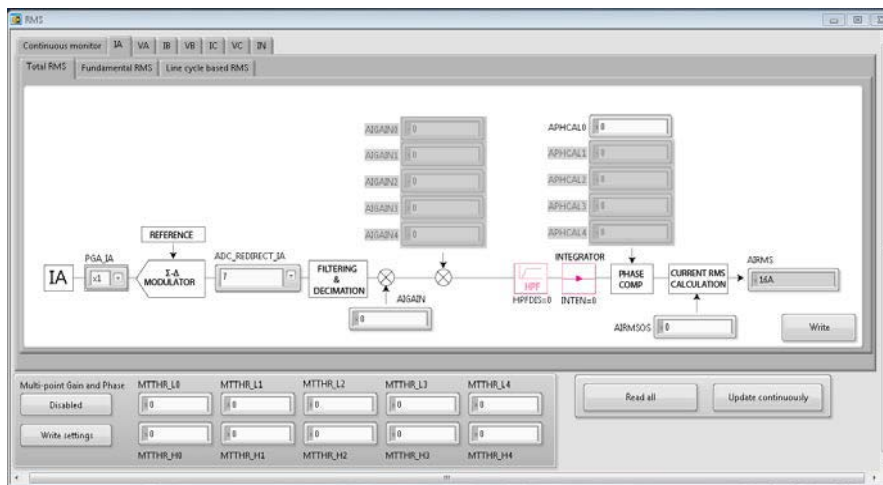

Figure 19. IA Tab (Total RMS Subtab) in the RMS Window

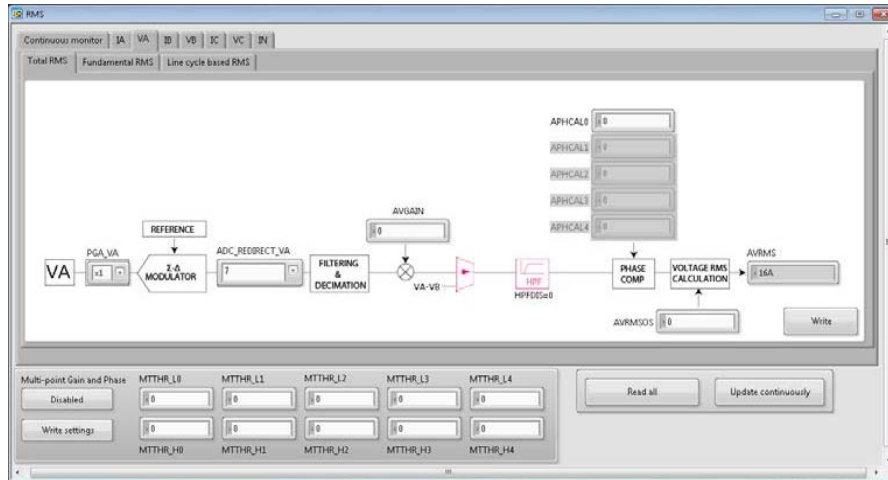

Figure 20. VA Tab (Total RMS Subtab) in the RMS Window

**WAVEFORM BUFFER WINDOW**

The **Waveform Buffer** window has two panes. The upper pane of the window controls the different settings of the waveform buffer. Settings such as the operation mode, specifying which channels burst, the source of the waveforms, and the number of samples to be collected are selected from this upper pane of the window. After all the settings are entered, click **Run** to start the filling process of the buffer. When the filling is complete, the buffer samples are plotted in the time domain under the **Waveforms** tab. Figure 21 shows the **Waveform Buffer** window with the **Waveforms** tab selected.

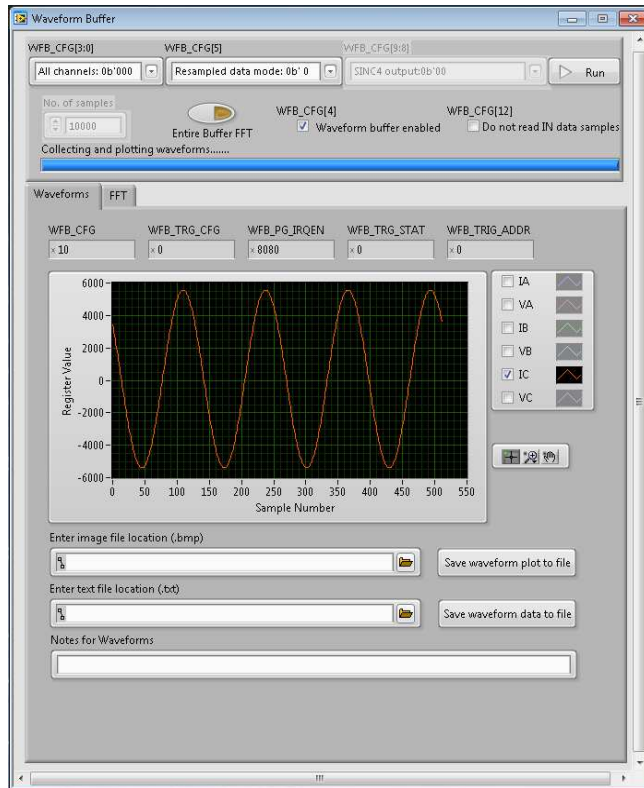

Figure 21. Waveforms Tab in the Waveform Buffer Window

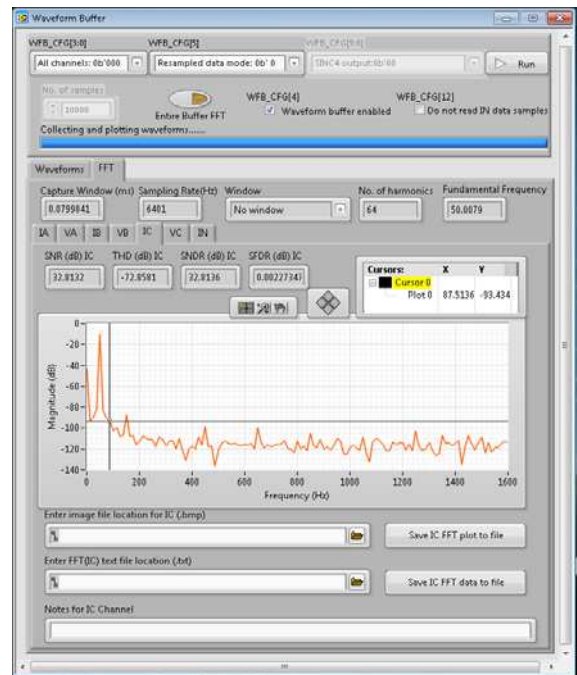

Figure 22. FFT Tab in the Waveform Buffer Window

When the **FFT** tab is selected, the window appears as shown in Figure 22. The FFT of all the waveforms is computed and plotted automatically based on the waveforms. The window allows the user to save the waveform and FFT data into a text file. The waveform and FFT display images can be saved to a .bmp file as well.

**ANGLE WINDOW**

The **Angle** window is shown in Figure 23. This window allows the user to visualize the angles of three voltage and three current channels with respect to each other. In the **Angle register readings** pane, all nine angle register values are displayed. Using these register results, the angles are computed in degrees and displayed in their respective boxes. The dial to the right of the screen provides a phasor-like representation of the six signals.

The frequency values are displayed below the dial. These values are computed from the **COM PERIOD** and **APERIOD** register values. The **Angle** window does not require the user to perform a write. The user can save the values in the window to a file, perform a single read of the screen quantities, or perform a continuous update of the quantities using the respective options in the window.

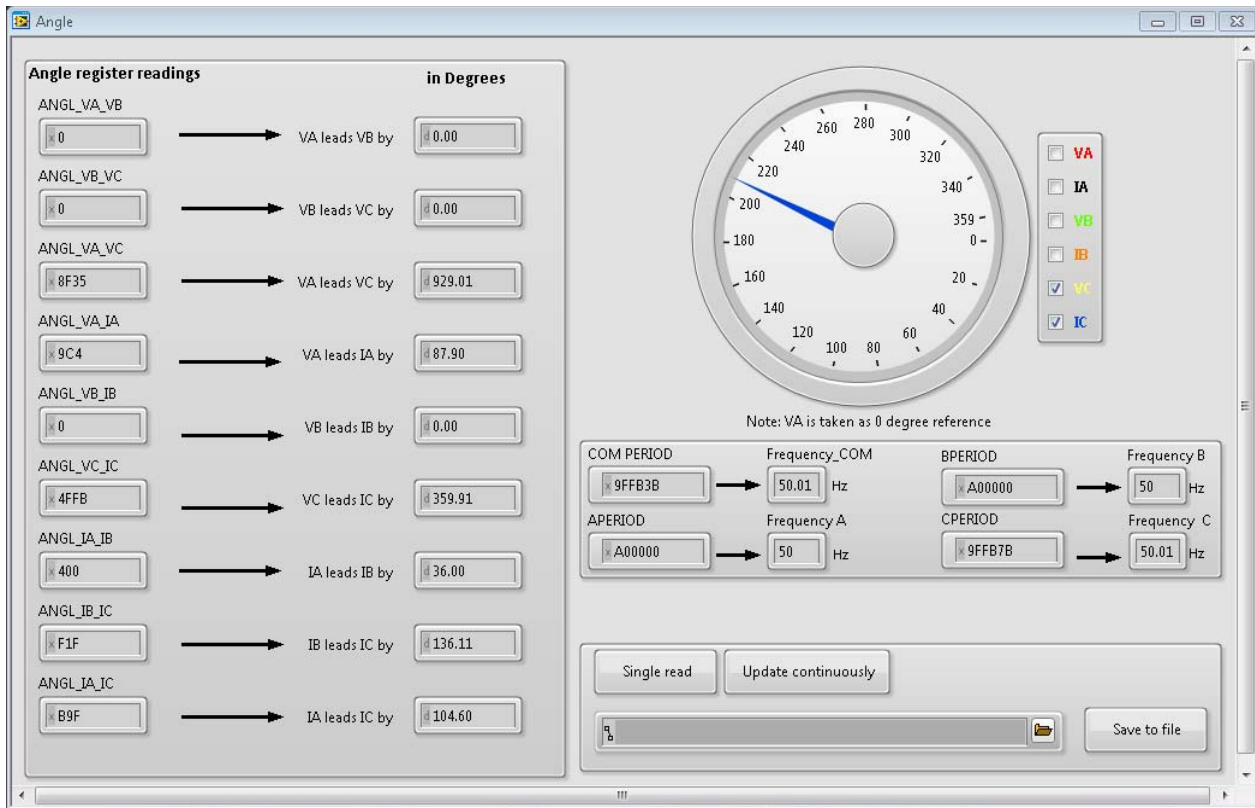

Figure 23. Angle Window

15296-024

**QUICK STARTUP WINDOW**

There are three tabs within the **Quick Startup** window: the **Configuration** tab, the **Input circuitry** tab, and the **Startup procedure** tab. The **Startup procedure** tab is the main tab that performs the quick start-up routine, as well as all the necessary initializations. However, before the start-up routine and the initializations, make sure that the inputs are operating in the correct 3-phase configuration and that they are not overranging the ADCs.

The **Configuration** tab accepts the user response on a few parameters and selects the appropriate **VCONSEL[2:0]** and **ICONSEL[0]** settings for the user. The **Input circuitry** tab can be used as a quick calculator for determining if the input signal exceeds the current channel and the voltage channel ADCs inside the **ADE9000**. By feeding in the system parameters and input signals, along with the PGA setting, the software calculates the signal level at the ADCs. If the signal level exceeds the full-scale range of the ADCs, the indicator turns red. This indication signals to the user that the system parameters must be adjusted.

The **Startup procedure** tab performs the following initialization steps, which must be completed sequentially (see Figure 26):

1. Sets the PGA for all channels.
2. Sets SELFREQ and VLEVEL.
3. Enables the integrator and sets **DICOEFF**. This step is skipped for everything except the di/dt sensor.
4. Enables the DSP.
5. Disables the CF1 to CF4 pin outputs, enables the energy and powers functionality, and reads all the energy registers on reset.
6. Performs a quick gain calibration and obtains calibration conversion constants, such as V/LSB, A/LSB, and Wh/LSB.
7. Obtains the CF1DEN to CF4DEN values from the **Meter constant** and writes these values to the registers.
8. Enables the CF1 and CF2 pins and configures them such that the CF1 pin denotes the sum of all the total active energy of the phases and the CF2 pin denotes the sum of all the total reactive energy phases.

These steps must be performed sequentially. The user must click the options in each step to perform the operation.

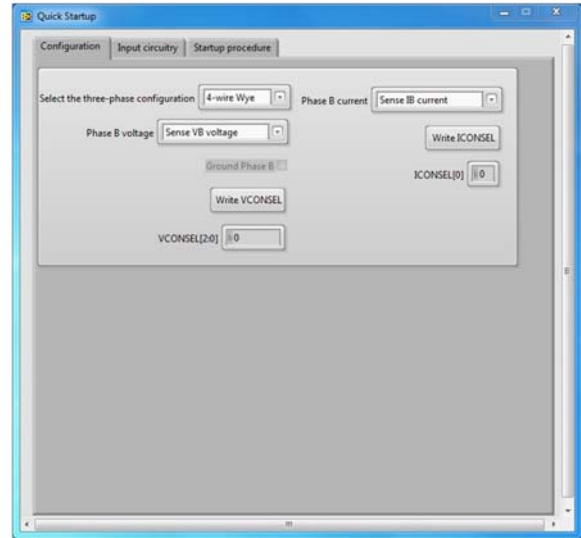

Figure 24. Configuration Tab in the Quick Startup Window

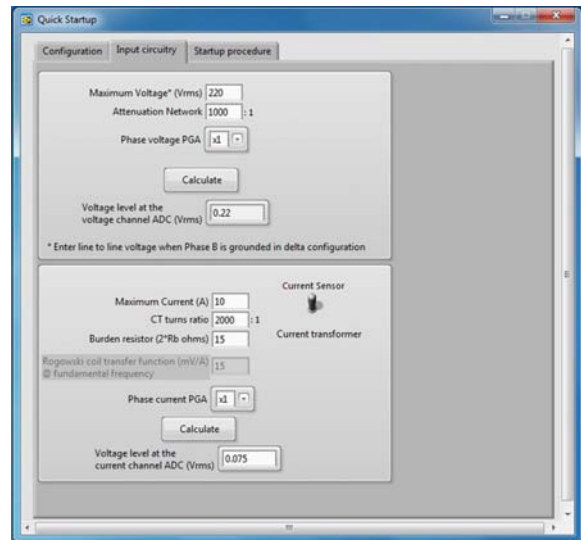

Figure 25. Input Circuitry Tab in the Quick Startup Window



Figure 26. Startup Procedure Tab in the Quick Startup Window

**INTERRUPTS WINDOW**

The **Interrupts** window displays the status of all the interrupt events. The individual bits of the **STATUS0** and **STATUS1** registers are shown as green LEDs in the window (see Figure 27). If the LED is lit, it indicates that the corresponding status bit is set to 1. Next to each of the LEDs, a checkbox represents the corresponding **MASK0** and **MASK1** bits. If the **MASK1** and **MASK0** bits must be set, select the corresponding checkbox and click **Write Mask Registers**. Click **Write '1' to all set status bits** to reset all status bits simultaneously. If specific values must be written to the

status bits, write to the bits using the controls under the **Write to STATUSx registers** option on the screen.

To view the **IRQ0** and **IRQ1** pin logic level, click **Check IRQx pin logic state**. If the LED is lit, this means that the pin is in a logic low state. Click **Auto Clear** to reset the interrupts available on the pins on the fly. The **IRQ0** and **IRQ1** pins can be monitored on a scope to understand the rate at which the interrupts are being set. The **Route all events to IRQ1 pin** option sets the configuration bit that routes all interrupt events to be accessible via the **IRQ1** pin.

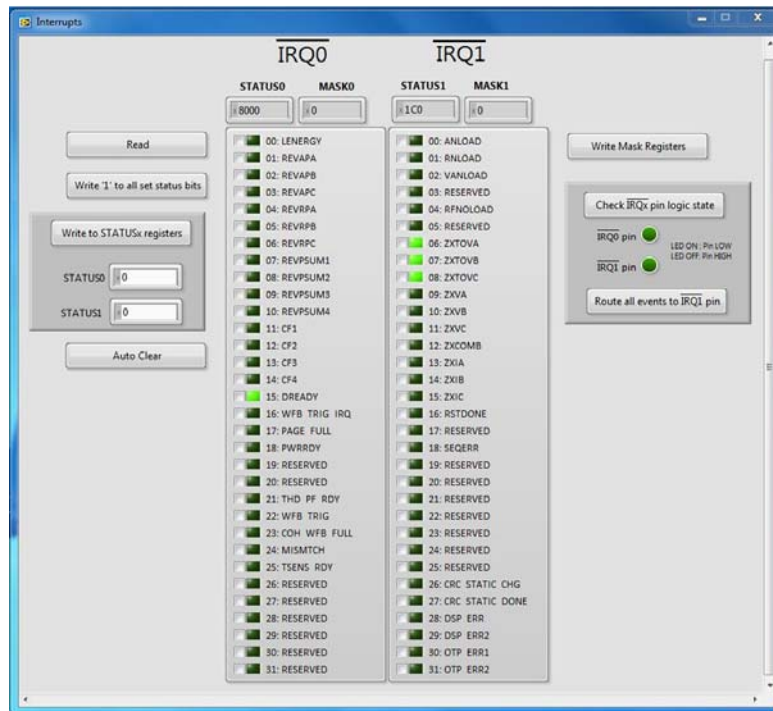

Figure 27. Interrupts Window

15326-02B

**POWER QUALITY WINDOW**

The **Power Quality** window allows the user to access all the power quality features of the **ADE9000**. The window is subdivided into the **Voltage monitor**, **Current monitor**, and **Power Factor and THD** tabs.

**Voltage Monitor Tab**

The **Voltage monitor** tab is shown in Figure 28. This tab evaluates the **DIP**, **SWELL**, **ZX & ZXTOUT**, **VPEAK**, and **PHASE SEQUENCE ERROR DETECTION** features. This tab

allows the user to configure all the control inputs for the features and to monitor the status bits as LEDs. The corresponding mask bits can also be set using the checkboxes in the tab.

**Current Monitor Tab**

The **Current monitor** tab is shown in Figure 29. This tab is organized in the same way as the **Voltage monitor** tab. The **IPEAK**, **ZX**, and **OI** power quality features are accessible in this tab.

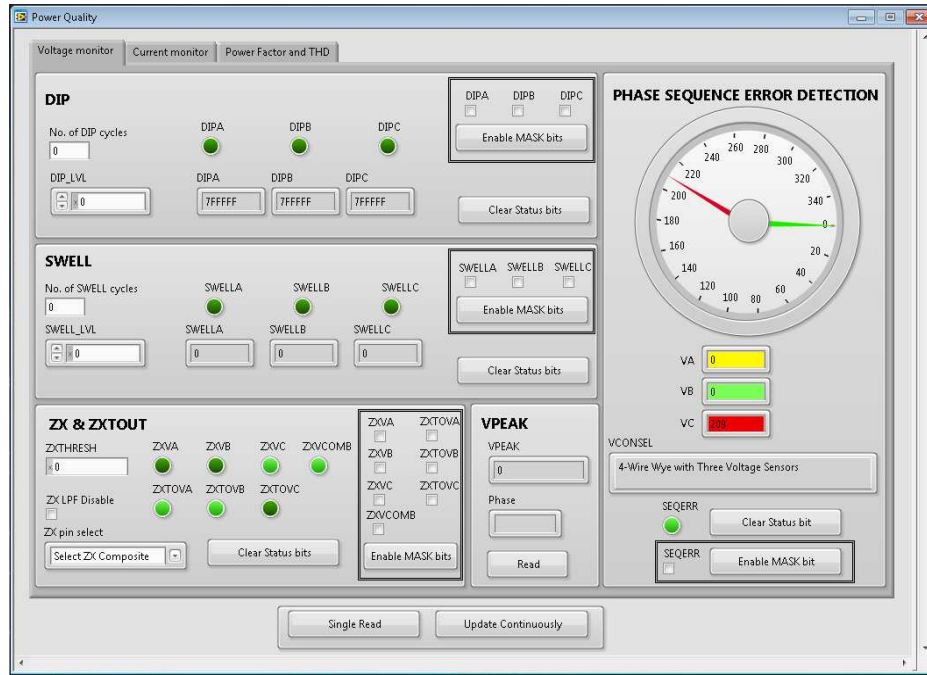

Figure 28. Voltage monitor Tab in the Power Quality Window

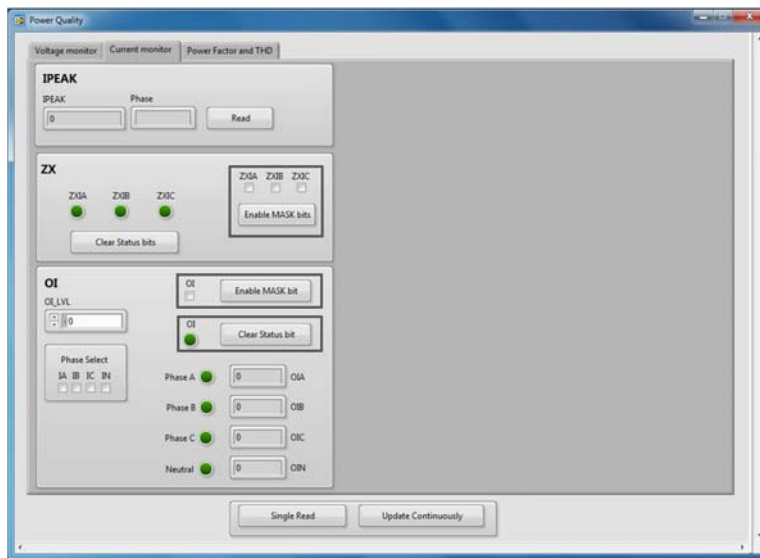

Figure 29. Current monitor Tab in the Power Quality Window

**Power Factor and THD Tab**

The **Power Factor and THD** tab is shown in Figure 30. This window reads all the power factor and total harmonic distortion

(THD) register results from the device, converts these results to meaningful results, and displays them.

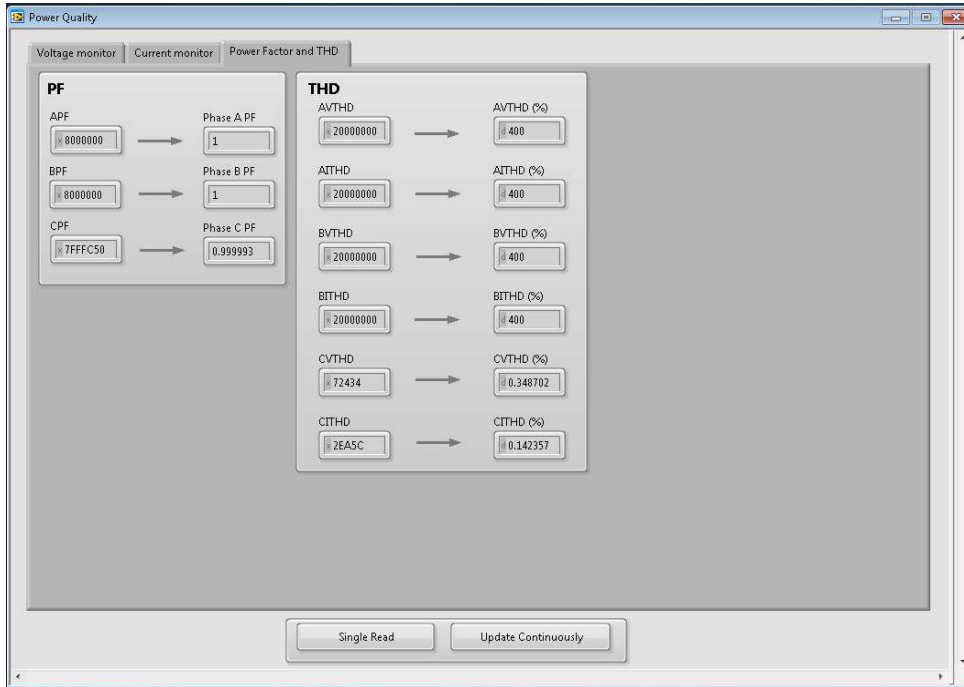

Figure 30. **Power Factor and THD** Tab in the **Power Quality** Window

## TROUBLESHOOTING

If the software does not detect the **SDP-B** board, the message shown in Figure 31 is displayed.

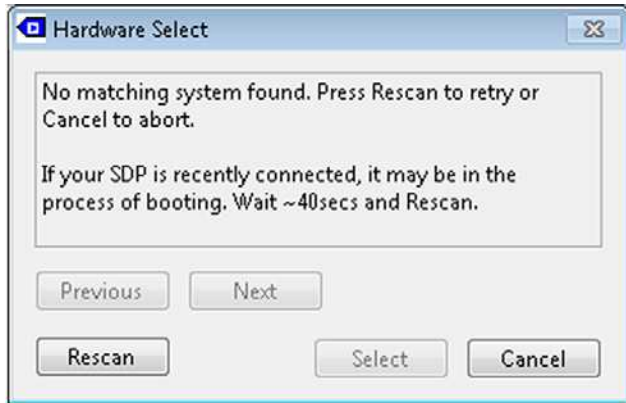

Figure 31. **Hardware Select** Message

If this message appears, take the following steps:

1. Verify that the **SDP-B** board is connected to the PC using the USB cable. The window in Figure 32 appears on the task bar; Windows then installs any other necessary drivers.
2. After the installation is complete, click **Rescan**.
3. When another window appears, check if the LED on the board is flashing; if so, click **Select**.

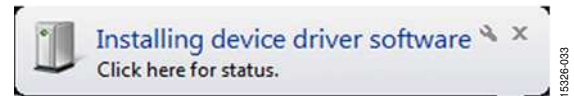

Figure 32. **Installing device driver software** Message

EVALUATION BOARD SCHEMATICS AND ARTWORK

865-926251

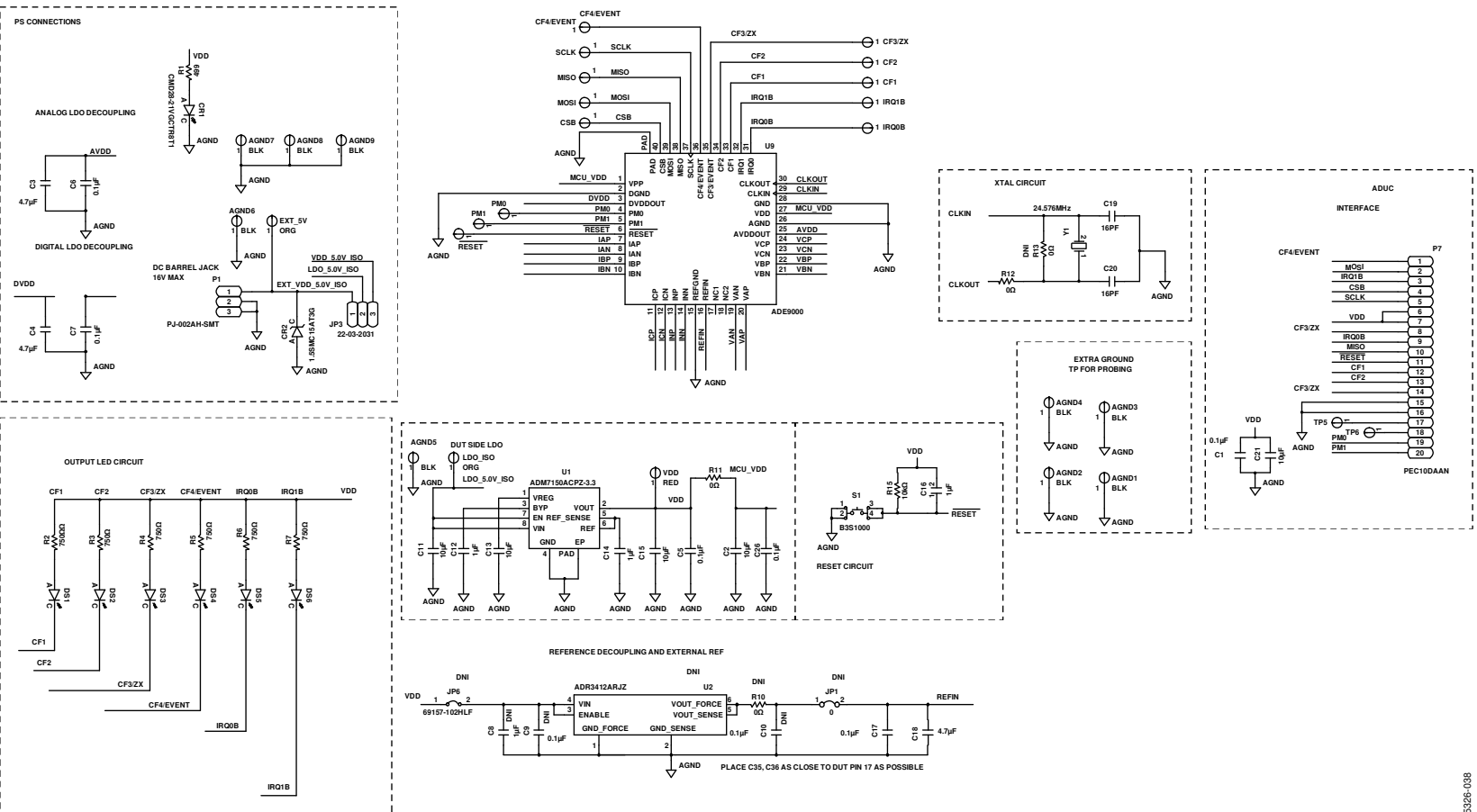

Figure 33. Evaluation Board Schematic—ADE9000

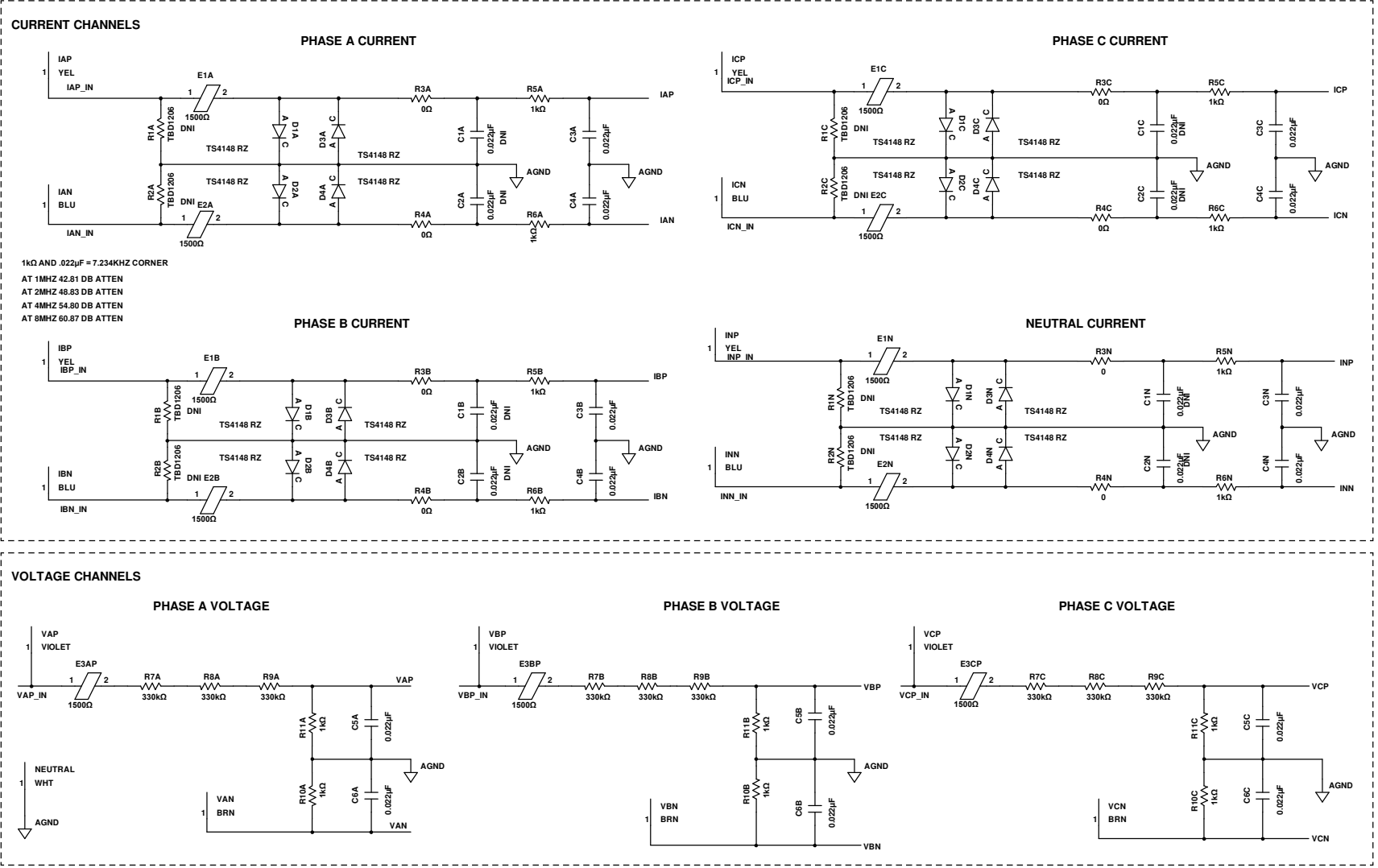

Figure 34. Evaluation Board Schematic—Current and Voltage Channels

153296-037