



Chipsmall Limited consists of a professional team with an average of over 10 year of expertise in the distribution of electronic components. Based in Hongkong, we have already established firm and mutual-benefit business relationships with customers from,Europe,America and south Asia,supplying obsolete and hard-to-find components to meet their specific needs.

With the principle of "Quality Parts,Customers Priority,Honest Operation,and Considerate Service",our business mainly focus on the distribution of electronic components. Line cards we deal with include Microchip,ALPS,ROHM,Xilinx,Pulse,ON,Everlight and Freescale. Main products comprise IC,Modules,Potentiometer,IC Socket,Relay,Connector.Our parts cover such applications as commercial,industrial, and automotives areas.

We are looking forward to setting up business relationship with you and hope to provide you with the best service and solution. Let us make a better world for our industry!



Contact us

Tel: +86-755-8981 8866 Fax: +86-755-8427 6832

Email & Skype: info@chipsmall.com Web: www.chipsmall.com

Address: A1208, Overseas Decoration Building, #122 Zhenhua RD., Futian, Shenzhen, China



EVAL-ADG936EB/EVAL-ADG936REB

FEATURES

Evaluation board for the ADG936/ADG936-R RF through for board calibration

INTRODUCTION

This application note describes the evaluation board for the ADG936/ADG936-R wideband switches.

The ADG936/ADG936-R are wideband analog switches that comprise two independently selectable SPDT switches using a CMOS process to provide high isolation and low insertion loss to 1 GHz. The ADG936 is an absorptive/matched dual SPDT with 50 Ω terminated shunt legs, and the ADG936-R is a reflective dual SPDT. These devices are designed such that the isolation is high over the dc to 1 GHz frequency range. They have on-board CMOS control logic and therefore eliminate the need for external controlling circuitry. The control inputs are CMOS compatible.

Full data on the ADG936/ADG936-R is available in the ADG936/ADG936-R data sheet at www.analog.com and should be consulted when using the evaluation board.

OPERATING THE EVAL-ADG936EB/ EVAL-ADG936REB

The ADG936x evaluation board allows designers to evaluate these high performance wideband switches with a minimum of effort. To prove that these devices meet the user's requirements, the user only requires a power supply and a network analyzer.

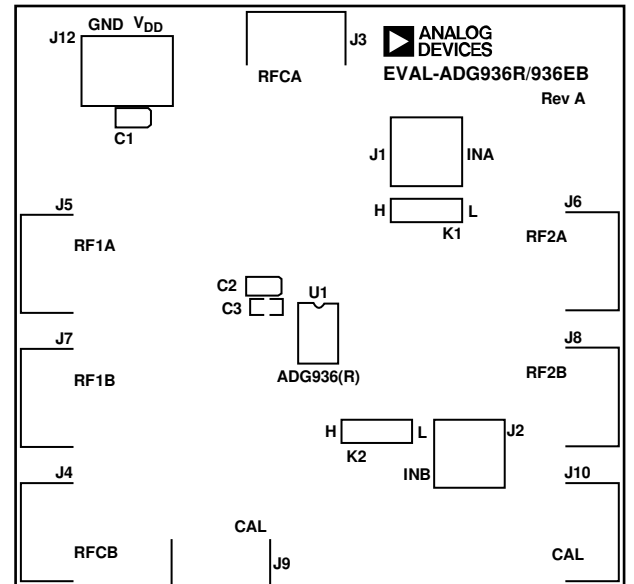

EVAL-ADG936R/936EB COMPONENT SIDE VIEW SILKSCREEN

Figure 1. Evaluation Board Top View

POWER SUPPLIES

To power the EVAL-ADG936EB/EVAL-ADG936REB, supply the voltage between the V_{DD} and GND inputs, J12, for the analog supply of the ADG936/ADG936-R. V_{DD} can range from 1.65 V to 2.75 V.

The control inputs, INA and INB, are applied by the SMB connectors or can be tied high to V_{DD} or low to GND by using the links (K1 and K2) on board. See Table 1 for details.

Table 1. Link Operation

INA (K1)	RF1A	RF2A
L	Off	On
H	On	Off
INB (K2)	RF1B	RF2B
L	Off	On
H	On	Off

Rev. 0

Information furnished by Analog Devices is believed to be accurate and reliable. However, no responsibility is assumed by Analog Devices for its use, nor for any infringements of patents or other rights of third parties that may result from its use. Specifications subject to change without notice. No license is granted by implication or otherwise under any patent or patent rights of Analog Devices. Trademarks and registered trademarks are the property of their respective owners.

EVAL-ADG936EB/EVAL-ADG936REB

EVAL-ADG936EB/EVAL-ADG936REB

The EVAL-ADG936EB/EVAL-ADG936REB allow designers to evaluate the high performance wideband switches with a minimum of effort.

The RFCA port is connected through a 50 Ω transmission line to a SMA connector, J3, and the RFCB port is connected through a 50 Ω transmission line to a SMA connector, J4. RF1A, RF2A, RF1B, and RF2B are connected through 50 Ω transmission lines to the SMA Connectors J5, J6, J7, and J8, respectively. A through transmission line connects J9 and J10, which is used to estimate the loss of the PCB over the environmental conditions being evaluated (see Figure 2).

The board is constructed of a 4-layer FR4 material with a dielectric constant of 4.3 and an overall thickness of 0.062 inches. Two ground layers with grounded planes provide ground for the RF transmission lines. The transmission lines were designed using a coplanar waveguide with a ground plane model using a trace width of 0.024 inches, a clearance to ground plane of 0.008 inches, a dielectric thickness of 0.02 inches, and a metal thickness of 0.0021 inches.

Two 10 μF surface-mount tantalum decoupling capacitors are provided on the V_{DD} line, with one placed close to the DUT along with a 100 pF ceramic capacitor on the V_{DD} line.

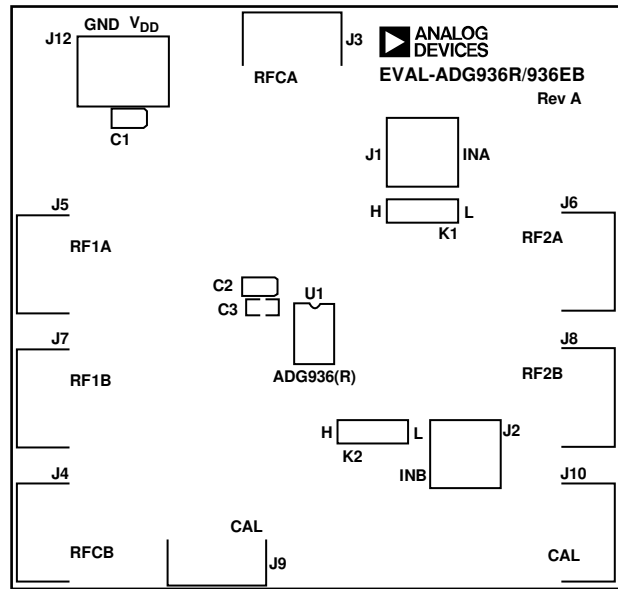

EVAL-ADG936R/936EB COMPONENT SIDE VIEW SILKSCREEN

Figure 2. ADG936x Evaluation Board Top View

Table 2. Components Listing

Item	Quantity	Reference	Part Description	Supplier/No.
1	2	C1, C2	10 μF , 10 V tantalum capacitors	FEC 197-130
2	1	C3	100 pF NPO ceramic capacitor	FEC 722-080
3	2	J1, J2	Straight SMB jacks	FEC 310-682
4	8	J3, J4, J5, J6, J7, J8, J9, J10	SMA end-launch RF connectors	Johnson Components 142-0701-851
5	1	J12	2-pin terminal block	FEC 151-785
6	2	K1, K2	JUMPER2\SIP3	FEC 512-047/FEC 150-410
7	1	U1	ADG936/ADG936R	Analog Devices, Inc.

ORDERING GUIDE

Model	Description
EVAL-ADG936REB	Evaluation Board
EVAL-ADG936EB	Evaluation Board

ESD CAUTION



ESD (electrostatic discharge) sensitive device. Charged devices and circuit boards can discharge without detection. Although this product features patented or proprietary protection circuitry, damage may occur on devices subjected to high energy ESD. Therefore, proper ESD precautions should be taken to avoid performance degradation or loss of functionality.