



Chipsmall Limited consists of a professional team with an average of over 10 year of expertise in the distribution of electronic components. Based in Hongkong, we have already established firm and mutual-benefit business relationships with customers from,Europe,America and south Asia,supplying obsolete and hard-to-find components to meet their specific needs.

With the principle of “Quality Parts,Customers Priority,Honest Operation,and Considerate Service”,our business mainly focus on the distribution of electronic components. Line cards we deal with include Microchip,ALPS,ROHM,Xilinx,Pulse,ON,Everlight and Freescale. Main products comprise IC,Modules,Potentiometer,IC Socket,Relay,Connector.Our parts cover such applications as commercial,industrial, and automotives areas.

We are looking forward to setting up business relationship with you and hope to provide you with the best service and solution. Let us make a better world for our industry!



Contact us

Tel: +86-755-8981 8866 Fax: +86-755-8427 6832

Email & Skype: info@chipsmall.com Web: www.chipsmall.com

Address: A1208, Overseas Decoration Building, #122 Zhenhua RD., Futian, Shenzhen, China



Evaluating the **ADM1062** to **ADM1169** for Complex Sequencing

FEATURES

Full-featured evaluation kits for **ADM1062** to **ADM1169**
I²C interface supports all product-related software
10 adjustable voltages reference for input emulation
Switch-controlled, open-drain/push-pull digital inputs
Extra headers for easy probing
Includes point to point patch cables for easy wiring
Multiboard cascade support

EVALUATION KIT CONTENTS

EVAL-ADM1062CASZ to EVAL-ADM1169CASZ
evaluation board
samples of the relevant device are included
ADM1062 to **ADM1169** device socket
8-way, 150 mm Micromatch ribbon cable
Patch cables

ADDITIONAL EQUIPMENT NEEDED

USB-to-I²C dongle **USB-SDP-CABLEZ**
9 V to 14.4 V power supply

RELATED DOCUMENTS

ADM1062 to **ADM1169** data sheets

SOFTWARE NEEDED

ADM1062 to **ADM1169** evaluation software

GENERAL DESCRIPTION

This user guide describes how to use the **ADM1062** to **ADM1169** evaluation kits. The kits provide all of the support circuitry required to operate the **ADM1062/ADM1063/ADM1064/ADM1065/ADM1066/ADM1067/ADM1068/ADM1069/ADM1166/ADM1168/ADM1169** (hereafter referred to as **ADM1062** to **ADM1169**) in their various modes and configurations, including multiple board setups. The **ADM1062** to **ADM1169** data sheets, available at www.analog.com, provide additional information, and should be consulted when using the evaluation board. All documents and software tools are available at www.analog.com/power-management.

Note that **USB-SDP-CABLEZ** is not included in the evaluation kit and should be ordered separately. Only one dongle is required in multiboard cascade setup. One device socket is included in each kit. Sockets for different device packages are not included. Refer to the Socket Selection Guide section for details regarding the corresponding socket types.

EVALUATION KIT SELECTION GUIDE

Table 1. Contents of Available Evaluation Kits

Evaluation Kit Model	Contains Evaluation Board	Contains IC Socket	Corresponding Devices
EVAL-ADM1062TQEBZ	EVAL-ADM1062-69CASZ	SOCKET-ADM106xTQZ	ADM1062ASUZ
EVAL-ADM1063TQEBZ	EVAL-ADM1062-69CASZ	SOCKET-ADM106xTQZ	ADM1063ASUZ
EVAL-ADM1064TQEBZ	EVAL-ADM1062-69CASZ	SOCKET-ADM106xTQZ	ADM1064ASUZ
EVAL-ADM1065TQEBZ	EVAL-ADM1062-69CASZ	SOCKET-ADM106xTQZ	ADM1065ASUZ
EVAL-ADM1066TQEBZ	EVAL-ADM1062-69CASZ	SOCKET-ADM106xTQZ	ADM1066ASUZ
EVAL-ADM1067TQEBZ	EVAL-ADM1062-69CASZ	SOCKET-ADM106xTQZ	ADM1067ASUZ
EVAL-ADM1068LQEBZ	EVAL-ADM1062-69CASZ	SOCKET-ADM106xLQZ	ADM1068ASTZ
EVAL-ADM1069LQEBZ	EVAL-ADM1062-69CASZ	SOCKET-ADM106xLQZ	ADM1069ASTZ
EVAL-ADM1166TQEBZ	EVAL-ADM1062-69CASZ	SOCKET-ADM106xTQZ	ADM1166ASUZ
EVAL-ADM1168LQEBZ	EVAL-ADM1062-69CASZ	SOCKET-ADM106xLQZ	ADM1168ASTZ
EVAL-ADM1169LQEBZ	EVAL-ADM1062-69CASZ	SOCKET-ADM106xLQZ	ADM1169ASTZ

TABLE OF CONTENTS

Features	1	I ² C Interface	4
Evaluation Kit Contents.....	1	Multiple Board Setup	4
Additional Equipment Needed	1	Switch, Jumper, and LED Functions.....	5
Related Documents	1	Socket Selection Guide	8
Software Needed	1	Margining Guide	9
General Description	1	Evaluation Kit Quick Start Guide.....	10
Evaluation Kit Selection Guide.....	1	Hardware Setup	10
Revision History	2	Software Setup	11
Evaluation Board Hardware	3	Demo 1	12
Supported Devices.....	3	Demo 2	13
Power Supplies	3	Evaluation Board Schematics.....	14
Inputs Emulation.....	3	Ordering Information.....	18
Output Signals.....	3	Bill of Materials.....	18

REVISION HISTORY

4/14—Rev. B to Rev. C

Change to Evaluation Kit Contents Section, Additional Equipment Section, and General Description Section.....	1
Change to I ² C Interface Section.....	4

7/13—Rev. A to Rev. B

Changes to Power Supplies Section and Figure 1.....	3
Changes to Demo 2 Section	13

9/11—Rev. 0 to Rev. A

Changes to Package Contents Section, changes to General Description Section, and Added Table 1	1
Changes to Output Signals Section and Changes to Figure 1	3
Changes to Figure 2.....	4
Changes to Table 2.....	5
Changes to Table 5.....	7
Added Evaluation Kits Quick Start Guide, added Figure 4 to Figure 16, Renumbered Sequentially	10

2/10—Revision 0: Initial Version

EVALUATION BOARD HARDWARE

The EVAL-ADM1062-69CASZ evaluation board is designed for advanced evaluation of [ADM1062](#) to [ADM1169](#) SuperSequencer® ICs. The board is easy to use, easy to probe, allows flexible wiring, and offers multiple board cascadability.

SUPPORTED DEVICES

The evaluation board is designed to support all [ADM1062](#) to [ADM1169](#) devices in various packages. A device socket is generally required for use with this board.

Devices can be easily fitted and changed using the [ADM1062](#) to [ADM1169](#) device sockets. Solder pads for a single 48-lead thin, plastic quad flat package (TQFP) is also available on the board, allowing the user to solder parts onto the board.

Note the labeling on the board. For example, VP1/VX4 indicates a change in function depending on the [ADM1062](#) to [ADM1169](#) device in use. The text on the left, VP1, is for use with the [ADM1062](#) to [ADM1067](#) and [ADM1166](#), whereas the text on the right, VX4, is for use with the [ADM1068/ADM1069/ADM1168/ADM1169](#).

POWER SUPPLIES

The evaluation board can accept 9 V to 14.4 V from a bench power supply through Connector J1 and Connector J2. It also supports a wall-mountable switching power supply with the same voltage range using Connector J3. J3 is grounded in the core and has polarity protection circuits to prevent damage due to incorrect polarity setup. The current consumption of the board depends on the exact configuration but is typically less than 200 mA.

INPUTS EMULATION

Ten onboard adjustable voltage regulators from Analog Devices, Inc., provide input supply emulation for all different setups supported by the [ADM1062](#) to [ADM1169](#) devices. Each regulator operates independently and output voltages can be easily adjusted by hand using an on-board rotating potentiometer.

Every regulator can be enabled or disabled by the user or by the [ADM1062](#) to [ADM1169](#) device, depending on the jumper configuration. Each regulator has an LED assigned to it to indicate its status.

All regulators have a feedback pin that allows the user to evaluate the margining function of the [ADM1062](#) to [ADM1169](#) devices.

An additional on-board two-way, push-pull/open-drain switch, S3, can be used by the user to emulate digital inputs, if required.

OUTPUT SIGNALS

PDO output signals from the [ADM1062](#) to [ADM1169](#) devices can be easily wired across to the regulator enable control circuits to control the on-board voltage regulators. This allows the board to perform simulations for real-world sequencing applications. The DAC output signals can also be wired to the feedback node of the regulators to achieve supply margining.

The wiring is made easy with the point-to-point patch cables included in the evaluation kit. The user can easily cross link the PDO output to a regulators enable input or connect DAC outputs to a regulator's feedback node.

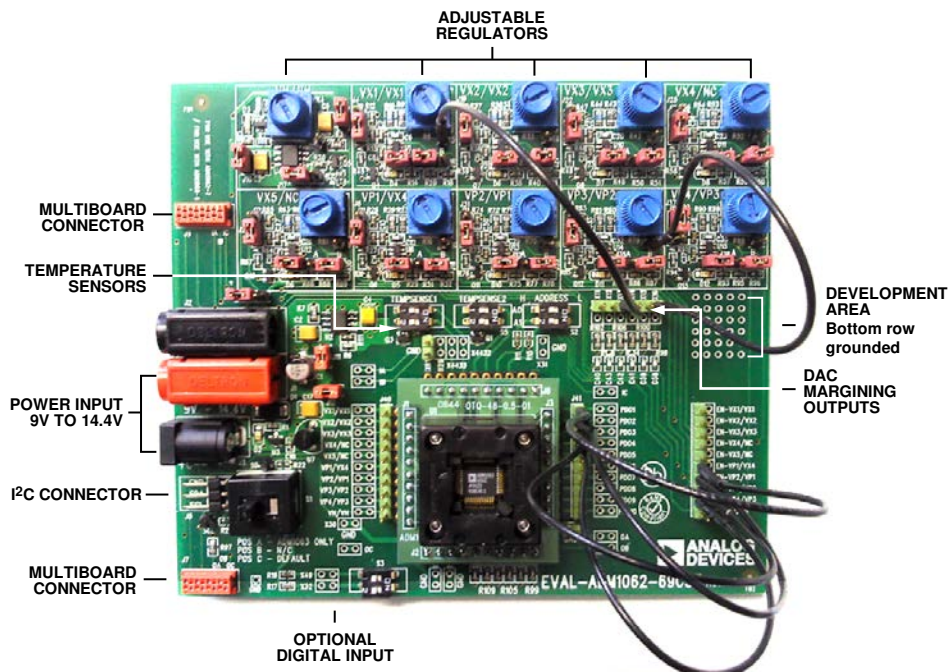

Figure 1. Evaluation Board Wiring with Point-To-Point Patch Cables

08644-001

I²C INTERFACE

The evaluation board supports an I²C interface. The user can connect from the PC USB port to the board using the [USB-SDP-CABLEZ](#) dongle from Analog Devices. The dongle has internal pull-ups for the SDA and SCL bus. Users can use their own I²C cable. The evaluation board can provide on-board 3.3 V voltage pull-up by populating R21 and R22.

The board is compatible with all [ADM1062](#) to [ADM1169](#) evaluation software.

MULTIPLE BOARD SETUP

Connector J7 and Connector J9, along with the eight-way ribbon cable, allow multiple EVAL-ADM1062-69CASZ boards to be connected together to evaluate complex cascade sequencing setups.

The connection cable carries both power and I²C communication signals across every board that is connected. The user only needs to connect the power and I²C cable to one board. It is recommended to connect the power supply to the board in the middle of the multiple board setup to avoid uneven power dissipation in the traces/cables.

Apart from power and I²C signals, the cable also links three independent GPIO signal lines between the two boards that it connects. The user can connect them to the inputs and/or outputs of the [ADM1062](#) to [ADM1169](#) devices to achieve sequencing across multiple boards. This allows multiple [ADM1062](#) to [ADM1169](#) devices to work together to increase the number of supply rails to be sequenced and monitored.

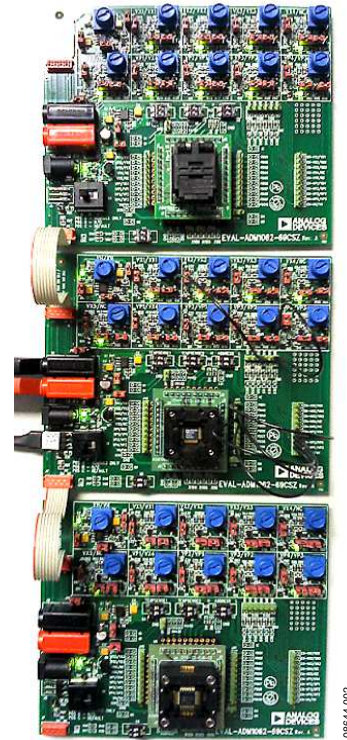

Figure 2. Multiple Boards Connection

SWITCH, JUMPER, AND LED FUNCTIONS**Table 2. Connector Functions**

Switch	Description	Default
S1 S1-A	I ² C/mode control switch. Position A allows the use of the ADM1063 device. Position B allows the board to be isolated from I ² C communications. Position C allows the use of the ADM1062 , ADM1064 to ADM1069 , ADM1166 , ADM1168 , and ADM1169 devices.	Position C
S2 S2-1	Device address switch. On: Address Pin A0 pulled down to ground. Off: Address Pin A0 pulled up to VDDCAP.	Off
S2-2	On: Address Pin A1 pulled down to ground. Off: Address Pin A1 pulled up to VDDCAP.	Off
S3 S3-1	Optional digital input switch. Use in conjunction with X49. X49 connected: push-pull. X49 disconnected: open-drain. On: X49 pulled to ground. Off: X49 pulled to 3.3 V/high impedance.	Disconnected Off
S3-2	Use in conjunction with X32. X32 connected: push-pull. X32 disconnected: open-drain. On: X32 pulled to ground. Off: X32 pulled to 3.3 V/high impedance.	Disconnected Off
S4 S4-1, S4-2	External Temperature Sensor 1 control switch (for use with the ADM1062 and ADM1063). Both on: External Temperature Sensor 1 connected. Both off: External Temperature Sensor 1 disconnected.	Both off
S5 S5-1, S5-2	External Temperature Sensor 2 control switch (for use with the ADM1063 only). Both on: External Temperature Sensor 2 connected. Both off: External Temperature Sensor 2 disconnected.	Both off

Table 3. Jumper Functions

Jumper	Corresponding Regulator/Rails	Description	Default
J13	VH/VH	Rail isolation jumper. Disconnect to isolate the corresponding regulators from its power supply. Can be used for debug.	Connected
J6	VX1/VX1		
J20	VX2/VX2		
J23	VX3/VX3		
J26	VX4/NC		
J29	VX5/NC		
J14	VP1/VX4		
J32	VP2/VP1		
J35	VP3/VP2		
J38	VP4/VP3		
J11	7 V (intermediate)		
J12	3.3 V (pull-up)		

Jumper	Corresponding Regulator/Rails	Description	Default
J10	VH	Controls the output of the VH regulator.	Connected
J15	ADM1062 to ADM1169 VH pin	Controls the source voltage connected to the VH pin of the ADM1062 to ADM1169 device. Connect left: connect VH pin to on-board VH regulator. Connect right: connect VH pin directly to board supply. Leave unconnected: leave VH pin unconnected.	Connect left
J17	VH/VH	Regulator control jumpers. Position A: regulator always on. Position B: regulator controlled by the PDO output signal of the ADM1062 to ADM1169. Unplugged: regulator shutdown.	Position A
J16	VX1/VX1		
J21	VX2/VX2		
J24	VX3/VX3		
J27	VX4/NC		
J30	VX5/NC		
J18	VP1/VX4		
J33	VP2/VP1		
J36	VP3/VP2		
J39	VP4/VP3		
J4	VX1/VX1	Regulator output voltage divider control jumpers. Position A: normal regulator output. Position B: 1/3 of normal regulator output. Unplugged: disconnect regulator output.	Position A
J19	VX2/VX2		
J22	VX3/VX3		
J25	VX4/NC		
J28	VX5/NC		
J8	VP1/VX4		
J31	VP2/VP1		
J34	VP3/VP2		
J37	VP4/VP3		
J40	VXx/VPx/VH		
J41	PDOx	Connector used for device outputs probing.	

Table 4. LED Functions

LED	Rails	Description
D3	VH/VH	Power indication LEDs. On position indicates voltage on corresponding rail.
D4	VX1/VX1	
D6	VX2/VX2	
D7	VX3/VX3	
D8	VX4/NC	
D9	VX5/NC	
D5	VP1/VX4	
D10	VP2/VP1	
D11	VP3/VP2	
D12	VP4/VP3	
D2	Board main power input	

Table 5. Patching Through-Hole Connection Points

Connection Points	Connected To	Description
VX1/VX1 VX2/VX2 VX3/VX3 VX4/NC VX5/NC VP1/VX4 VP2/VP1 VP3/VP2 VP4/VP3 VH/VH	VX1/VX1 pin of the ADM1062 to ADM1169 VX2/VX2 pin of the ADM1062 to ADM1169 VX3/VX3 pin of the ADM1062 to ADM1169 VX4/NC pin of the ADM1062 to ADM1169 VX5/NC pin of the ADM1062 to ADM1067 and ADM1166 VP1/VX4 pin of the ADM1062 to ADM1169 VP2/VP1 pin of the ADM1062 to ADM1169 VP3/VP2 pin of the ADM1062 to ADM1169 VP4/VP3 pin of the ADM1062 to ADM1067 and ADM1166 VH/VH pin of the ADM1062 to ADM1169	Input connections of the ADM1062 to ADM1169 .
PDO1 PDO2 PDO3 PDO4 PDO5 PDO6 PDO7 PDO8 PDO9 PDO10	PDO1 pin of the ADM1062 to ADM1169 PDO2 pin of the ADM1062 to ADM1169 PDO3 pin of the ADM1062 to ADM1169 PDO4 pin of the ADM1062 to ADM1169 PDO5 pin of the ADM1062 to ADM1169 PDO6 pin of the ADM1062 to ADM1169 PDO7 pin of the ADM1062 to ADM1169 PDO8 pin of the ADM1062 to ADM1169 PDO9 pin of the ADM1062 to ADM1067 and ADM1166 PDO10 pin of the ADM1062 to ADM1067 and ADM1166	Output connections of the ADM1062 to ADM1169 .
EN-VX1/VX1 EN-VX2/VX2 EN-VX3/VX3 EN-VX4/NC EN-VX5/NC EN-VP1/VX4 EN-VP2/VP1 EN-VP3/VP2 EN-VP4/VP3 EN-VH/VH	VX1/VX1 regulator VX2/VX2 regulator VX3/VX3 regulator VX4/NC regulator VX5/NC regulator VP1/VX4 regulator VP2/VP1 regulator VP3/VP2 regulator VP4/VP3 regulator VH/VH regulator	Connected to the enable circuit of the regulators; connect to PDO outputs directly to allow the ADM1062 to ADM1169 device to take control of the regulator.
X11 X12 X13 X14	DAC1 pin of the ADM1062 , ADM1066 , ADM1067 , ADM1069 , ADM1166 , and ADM1169 DAC2 pin of the ADM1062 , ADM1066 , ADM1067 , ADM1069 , ADM1166 , and ADM1169 DAC3 pin of the ADM1062 , ADM1066 , ADM1067 , ADM1069 , ADM1166 , and ADM1169 DAC4 pin of the ADM1062 , ADM1066 , ADM1067 , ADM1069 , ADM1166 , and ADM1169	DAC outputs of the ADM1062 , ADM1066 , ADM1067 , ADM1069 , ADM1166 , and ADM1169
X15 X16	DAC5 pin of the ADM1062 , ADM1066 , ADM1067 , ADM1069 , and ADM1166 DAC6 pin of the ADM1062 , ADM1066 , ADM1067 , ADM1069 , and ADM1166	DAC outputs of the ADM1062 , ADM1066 , ADM1067 , ADM1069 , and ADM1166

Connection Points	Connected To	Description
T4 T5 T6 T7 T8 T9 T10 T11 T12 T13	SET pin of VH/VH regulator (ADP3367) Feedback pin of the VX1/VX1 regulator Feedback pin of the VX2/VX2 regulator Feedback pin of the VX3/VX3 regulator Feedback pin of the VX4/NC regulator Feedback pin of the VX5/NC regulator Feedback pin of the VP1/VX4 regulator Feedback pin of the VP2/VP1 regulator Feedback pin of the VP3/VP2 regulator Feedback pin of the VP4/VP3 regulator	Connected to the feedback pin of the regulators; connect to the X11 to X16 inputs for supply margining (see the Margining Guide section).
X49 X32	S3-1 S3-2	Optional digital inputs can be set as open-drain or push-pull.
IA IB IC	J9 (OA of the connected board) J9 (OB of the connected board) J9 (OC of the connected board)	I/Os for multiple board setup.
OA OB OC	J7 (IA of the connected board) J7 (IB of the connected board) J7 (IC of the connected board)	I/Os for multiple board setup.

SOCKET SELECTION GUIDE

Table 6.

Model	Description	Corresponding Devices
SOCKET-ADM106xTQZ	ADM1062TQ to ADM1166TQ daughter card	ADM1062 to ADM1067 and ADM1166 in TQFP
SOCKET-ADM106xLFZ	ADM1062LF to ADM1166LF daughter card	ADM1062 to ADM1067 and ADM1166 in LFCSP
SOCKET-ADM106xLQZ	ADM1068LQ to ADM1169LQ daughter card	ADM1068 , ADM1069 , ADM1168 and ADM1169 in LQFP
SOCKET-ADM1069LFZ	ADM1069LF daughter card	ADM1069 and ADM1169 in LFCSP

MARGINING GUIDE

The [ADP3331](#) LDO is used to provide adjustable V_X and V_P input voltages.

The feedback topology for this part is different from other regulators (see Figure 3). Another voltage divider is used inside the part to provide feedback voltage to the error amplifier. This causes margining calculation in the [ADM1062](#) to [ADM1169](#) evaluation software tool to be different.

A separate Excel tool has been created for users to calculate the settings for margining function.

Note that closed-loop margining is less affected by this topology, although the margining range may differ from the calculated values in the software tool. For the V_H pin, the use of [ADP3367](#) results in the margining functions performing correctly with both open and closed loop.

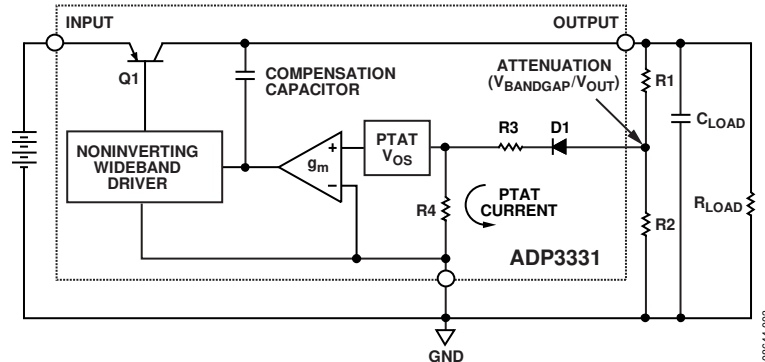

Figure 3. [ADP3331](#) Functional Diagram

EVALUATION KIT QUICK START GUIDE

HARDWARE SETUP

For **ADM1062 to ADM1067** and **ADM1166** Evaluation Kits

1. Put jumpers J4, J19, J22, J25, and J28 into Position A. This puts the output of LDOs connected to VXx inputs to lower voltage ranges.
2. Put jumpers J16, J21, J24, J27, J30, J18, J33, J36, and J39 into Position B. This makes the LDOs connected to VXx and VPx inputs enabled by external signals.
3. Use the point-to-point patch cables to connect the PDOx pins to the enable pins of the LDOs as shown in Figure 4 and Figure 5.

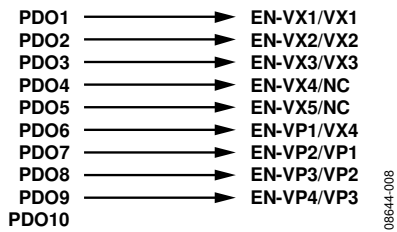

Figure 4. Demo Patch Connection 1

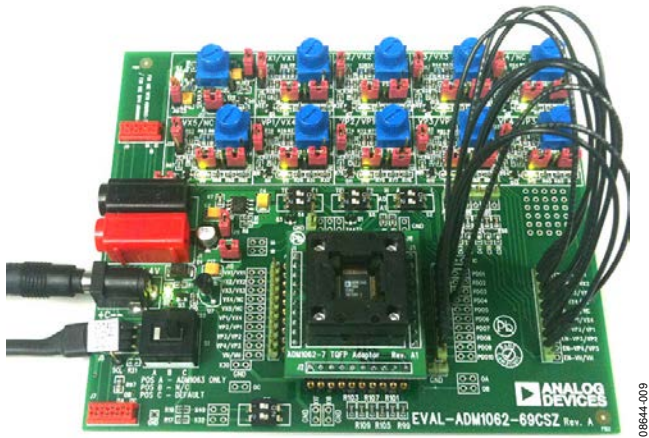

Figure 5. Evaluation Kit Quick Start Setup

For **ADM1068 to ADM1069** and **ADM1168 to ADM1169** Evaluation Kits

1. Put jumpers J4, J19, and J22 into Position A. This puts the output of LDOs connected to VXx inputs to a lower voltage range.
2. Remove the jumpers J27 and J30 to disable the LDOs that are not used.
3. Put jumpers J16, J21, J24, J18, J33, J36, and J39 into Position B. This makes the LDOs connected to VXx and VPx inputs enabled by external signals.
4. Use the point-to-point patch cables to connect the PDOx pins to the enable pins of the LDOs as shown in Figure 6.

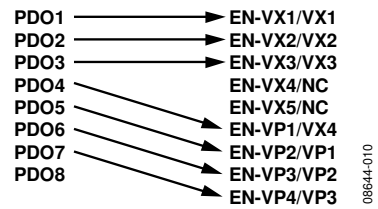

Figure 6. Demo Patch Connection 2

5. For the **ADM1063** evaluation kit, switch S1 to Position A.
6. Keep every other switch and jumper in the default positions.
7. Place the device into the IC socket, and connect the board to the PC using the USB-to-I²C dongle.
8. Apply power to the board.

SOFTWARE SETUP

1. Download and install the ADM106x and ADM116x Super-Sequencer [evaluation software](#) from analog.com. The software package includes a GUI evaluation tool, a command-line based Prog106x tool, and USB-to-I²C dongle drivers.
2. Download the [Supersequencer quick start demo configurations.zip](#) file; this contains the device configuration files for the demo. There are two demo configurations for each device types, demo1 and demo2. Each configuration is saved in both *.txt and *.hex format. Users can use the GUI evaluation software to load the *.txt file or use the Prog106x tool to load the *.hex file. This user guide describes the former; for details of the Prog106x tool refer to user guide UG-049.
3. Run the GUI ADM106x and ADM116x SuperSequencer evaluation software, and select the appropriate I²C interface, then click **Work Online** as shown in Figure 7.

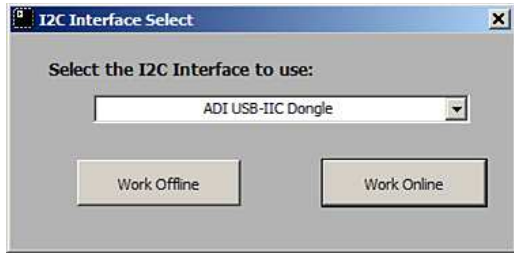

Figure 7. I²C Interface Select

08644-011

4. The software searches for all the [ADM1062](#) to [ADM1169](#) devices connected to the interface. Verify the device and address that appears in the device list and click **Continue**.

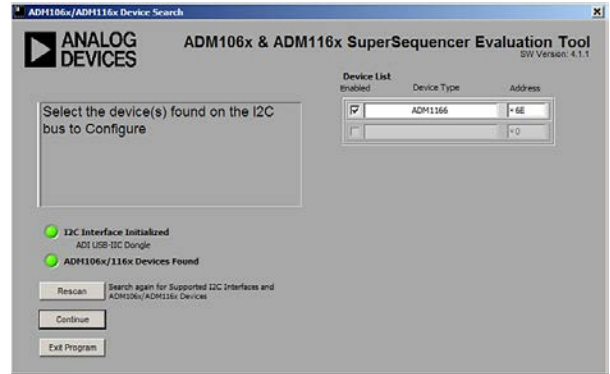

Figure 8. Device Search

08644-012

5. Click **No** in the pop-up window to prevent usage of information from the previous session.



Figure 9. Prevent Usage of Previous Information

08644-013

DEMO 1

1. Use the menu bar and navigate to **File->Recall Settings From File**, or use the shortcut key **Ctrl + R**.



Figure 10. Recall Settings

2. Click **Recall** and then navigate to and select the Demo1 .txt file of the appropriate device.

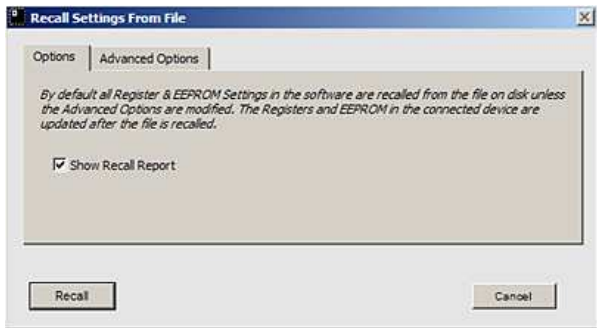

Figure 11. Recall Settings

3. Verify the checksums and click **OK**.



Figure 12. Verify Checksums

4. Observe the LEDs on the evaluation board flashing in periodic sequence. The Demo 1 configuration simply uses the timeout exit condition of the sequencing engine to sequence the enable signals of the LDOs.
5. Examine the details of the device outputs configuration and sequencing engine content in the **Outputs and Sequencing Engine** tabs of the GUI as shown in Figure 13 and Figure 14.

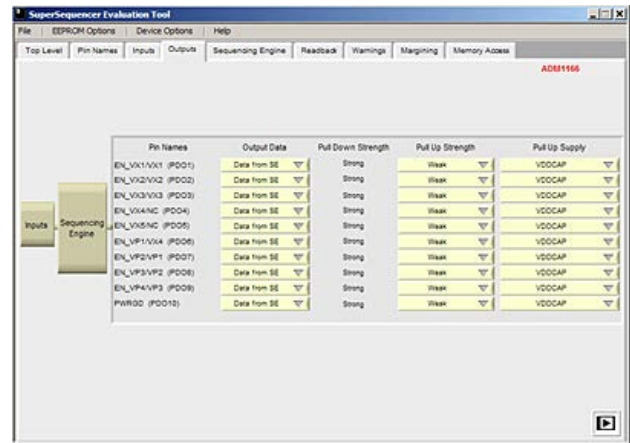

Figure 13. Outputs Tab

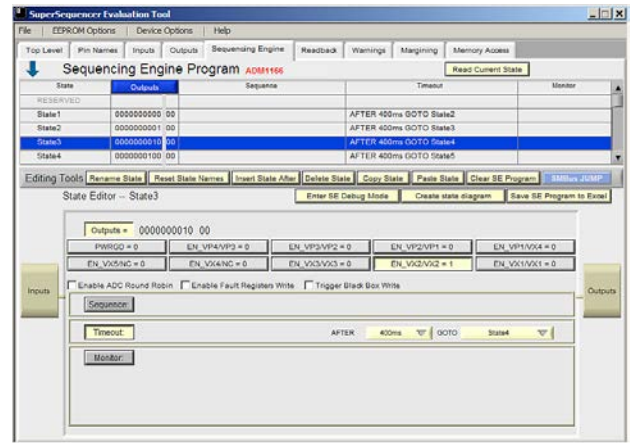

Figure 14. Sequencing Engine Tab

DEMO 2

Use the same method described in the Demo 1 section to load the corresponding Demo 2 configuration .txt file into the device.

The sequencing engine configuration in Demo 2 is more complex and closely resembles the setup for a real application. Most of the sequencing engine states use all three exit conditions, namely sequence, timeout, and monitor. The status of each supply being enabled is checked, ensuring that all supplies are powered up to the correct level and are stable before advancing the sequencing engine.

If the supply did not rise to the expected level after the timeout period, the sequencing engine can exit to a user-defined fault state. In each state, the sequencing engine also monitors the status of the supplies being enabled in previous states to ensure the integrity of the supply chain. The status of each inputs can be defined using the **Inputs** tab shown in Figure 15.

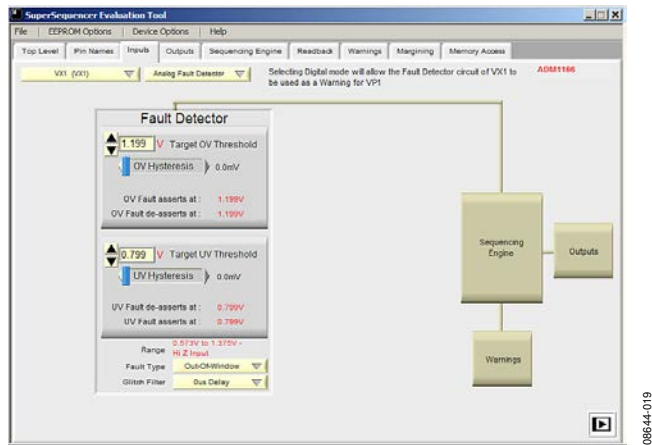

Figure 15. Inputs Tab

In Demo 2, a window comparator is applied to each of the inputs except for VH. Use the knob of on-board potentiometer to adjust the voltages on VXx and VPx inputs to the exact level in order to advance the sequencing engine, starting from VX1.

Observe the sequencing engine advancement based on the status of the on-board LEDs, or use a DMM to probe each VXx and VPx inputs while tweaking the knob to get the accurate voltage reading. For devices with ADC functions, use the **Readback** tab to continuously read the voltage level on each inputs as shown in Figure 16. Note that the J4, J19, J22, J25, J28 jumpers may need to be in Position B to achieve low voltage on the VXx inputs.

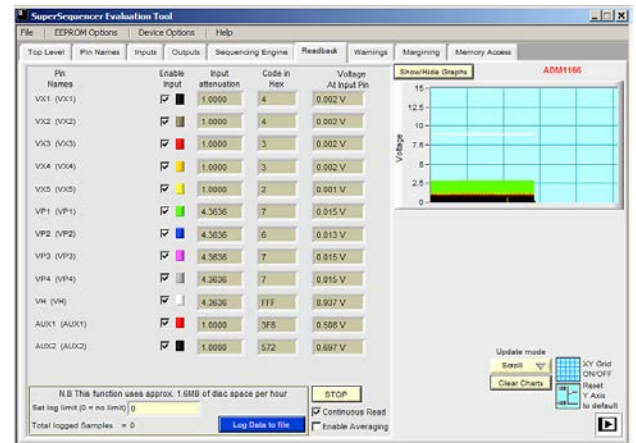
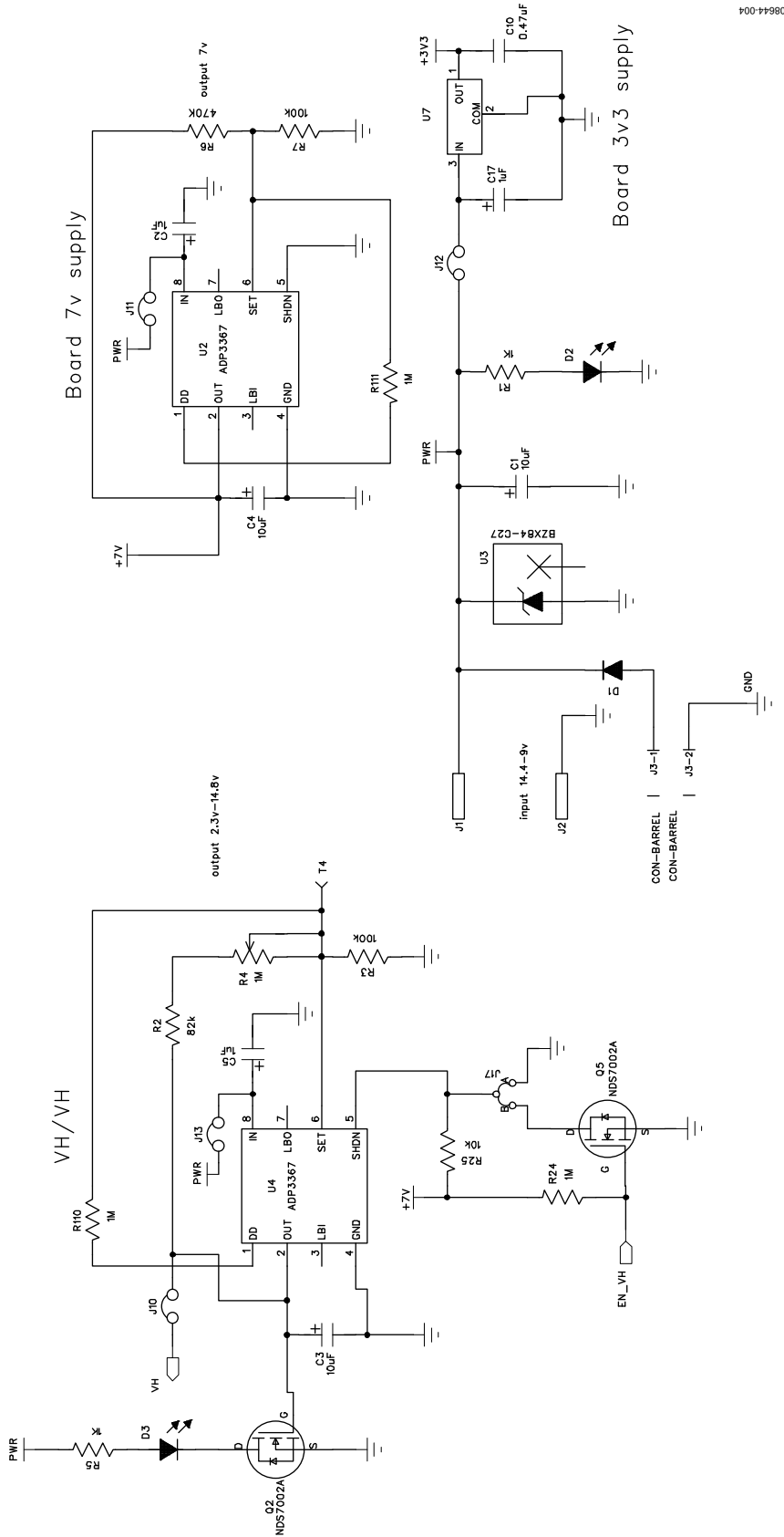

Figure 16. Readback Tab

EVALUATION BOARD SCHEMATICS



08644-004

Figure 17. Board Schematic 1

50044980

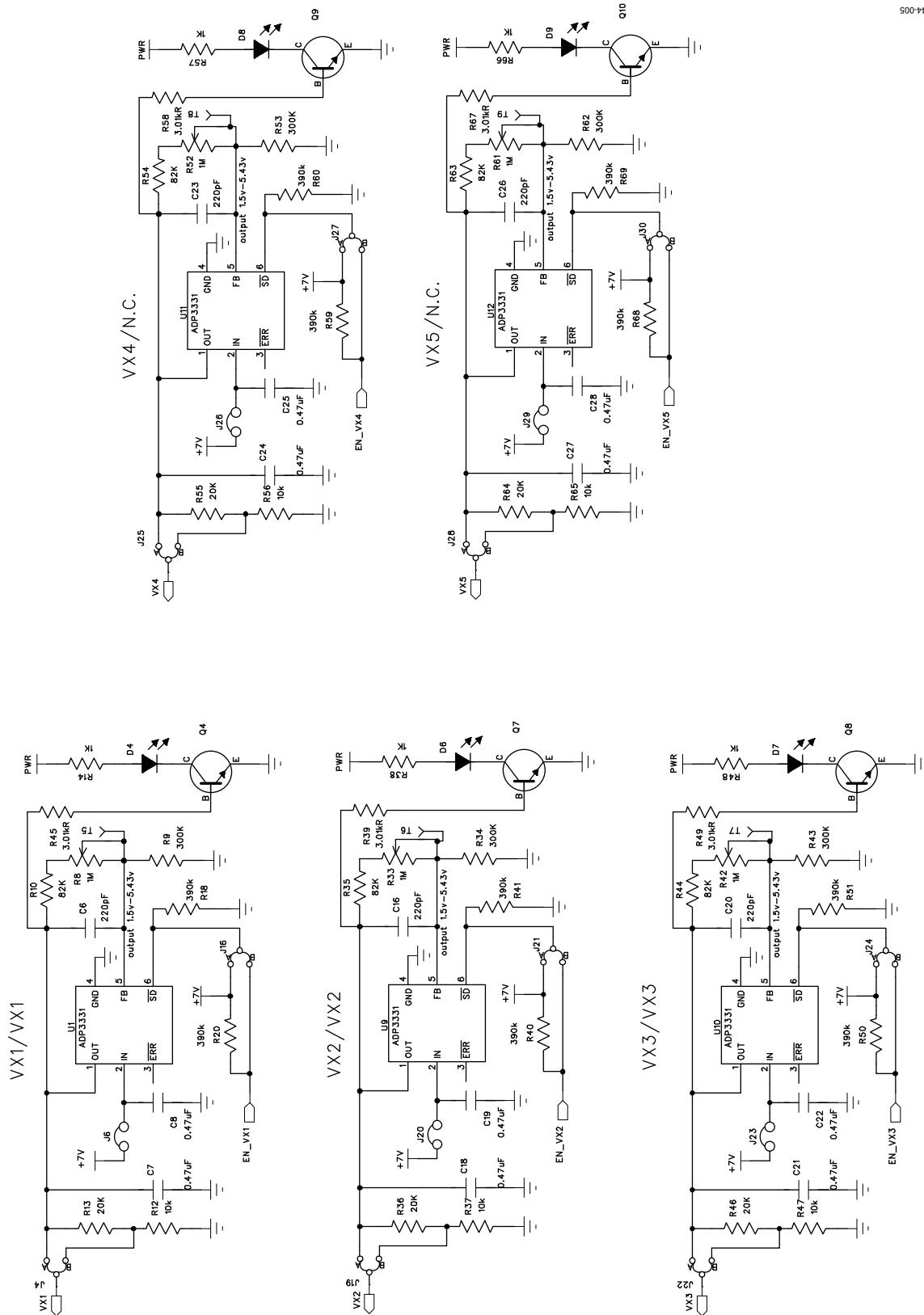

Figure 18. Board Schematic 2

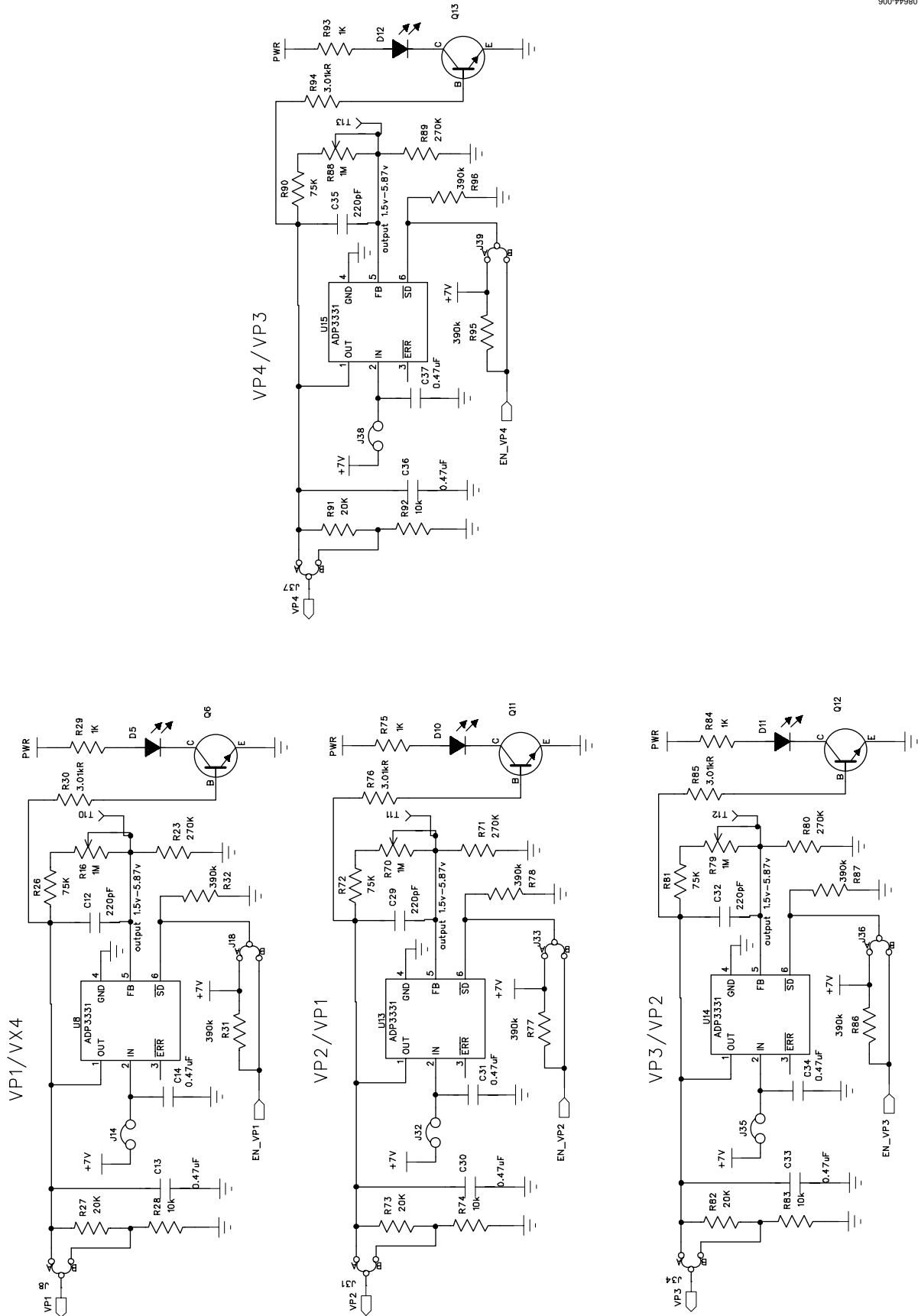

Figure 19. Board Schematic 3

ORDERING INFORMATION

BILL OF MATERIALS

Table 7.

Reference Designator	Description	Manufacturer	Part Number	Stock Code ¹
C1	Aluminum electrolytic capacitor, Case C, 35 V, 10 μ F	Panasonic	EEE1VA100SR	FEC 9697012
C7, C8, C10, C13, C14, C18, C19, C21, C22, C24, C25, C27, C28, C30, C31, C33, C34, C36, C37	SMD capacitor, 0.47 μ F, 20%	Phycomp	CC0603MRY5V7BB474	FEC 3188851
C3, C4, C9, C11, C15	16 V SMD tantalum capacitor, 10 μ F, 10%	AVX	TAJB106K016R	FEC 498-737
C6, C12, C16, C20, C23, C26, C29, C32, C35, C38, C39, C40 to C43	SMD capacitor, 220 pF, 5%	Phycomp	CC0603JRNPO9BN221	FEC 430948
C2, C5, C17	Capacitor, Case B, 1.0 μ F, 35 V, 10%	Kemet	B45196E6105K209	FEC 9754032
D1	Diode, Schottky, 2 A, 20 V, SMB	Vishay	SL22	FEC 9550780
D2 to D12	Green 0805 chip LED	Kingbright	KP-2012SGC	FEC 1318243
EN-VH/VH, EN-VP1/VX4, EN-VP2/VP1, EN-VP3/VP2, EN-VP4/VP3, EN-VX1/VX1, EN-VX2/VX2, EN-VX3/VX3, EN-VX4/NC, EN-VX5/NC	Patchwork area, not populated	N/A	N/A	N/A
GND, IA, IB, IC	Plated hole, keep free of solder	N/A	N/A	N/A
J1	Red 4 mm banana socket	Deltron	571-0500-01	FEC 1101127
J2	Black 4 mm banana socket	Deltron	571-0100-01	FEC 1101128
J6, J10 to J14, J20, J23, J26, J29, J32, J35, J38	2-pin (0.1" pitch) header and shorting shunt	Harwin	M20-9990246, M7566-05	FEC 1022247, FEC 150-411
J4, J8, J15 to J19, J21, J22, J24, J25, J27, J28, J30, J31, J33, J34, J36, J37, J39	3-pin (0.1" pitch) header and shorting shunt inserted in Position A	Harwin	M20-9990346, M7566-05	FEC 1022249, FEC 150-411
J3	2.1 mm dc barrel power connector	Cliff	DC10A	FEC 224-959
J40, J41	Header, 1-row, 10-way	Tyco Electronics	1-826629-0	FEC 3418376
J5	Header, right angle, 1-row, 3-way	Harwin	M22-2030305	FEC 672129
J7, J9	8-way top entry socket (board-to-board)	Tyco Electronics/Amp	7-215079-8	FEC 148593
OA, OB, OC, PDO1 to PDO10	Patchwork area, not populated	N/A	N/A	N/A
Q1, Q3	Transistor, PNP, SOT-23	NXP	BC807-40	FEC 1081222
Q2, Q5	N-channel, enhancement mode, TMOSFET	Fairchild	NDS7002A	FEC 984-5437
Q4, Q6 to Q13	General-purpose NPN SMD transistor	NXP	BC850C	FEC 1081241
R1, R5, R14, R29, R38, R57, R48, R66, R75, R84, R93	Resistor, RC22H, 0603, 1 k Ω , 1%	Phycomp	RC0603FR-071KL	FEC 9238484
R2, R10, R35, R44, R54, R63	Resistor, 0603, 82 k Ω , 1%	Multicomp	MC 0.063W 0603 1% 82K	FEC 9331573
R3, R7	Resistor, RC22H, 0603, 100 k Ω , 1%	Phycomp	RC0603FR-07100KL	FEC 9238727
R4, R8, R16, R33, R42, R52, R61, R70, R79, R88	3/8" square (10 mm) single-turn potentiometer, 1 M Ω	Vishay	M63M105KB30T607	FEC 9608290
R6	Resistor, RC22H, 0603, 470 k Ω , 1%	Phycomp	RC0603FR-07470KL	FEC 9238808
R11, R15	Resistor, 110 k Ω , 1%	Multicomp	MC 01W 0603 1% 110K	FEC 9332464
R12, R17, R19, R25, R28, R37, R47, R56, R65, R74, R83, R92	10 k Ω resistor, 1%	Vishay Dale	CRCW060310K0FKEA	FEC 1469748
R13, R27, R36, R46, R55, R64, R73, R82, R91	Resistor, 0603, 20 k Ω , 1%	Multicomp	MC 0.063W 0603 1% 20K	FEC 9330771
R18, R20, R31, R32, R40, R41, R50, R51, R59, R60, R68, R69, R77, R78, R86, R87, R95, R96	Resistor, 0603, 390 k Ω , 1%	Multicomp	MC 0.063W 0603 1% 390K	FEC 9331166

Reference Designator	Description	Manufacturer	Part Number	Stock Code ¹
R21, R22	DNP	N/A	N/A	Not assembled
R23, R71, R80, R89	Resistor, 0603, 270 k Ω , 1%	Multicomp	MC 0.063W 0603 1% 270K	FEC 9330941
R24, R110, R111	Resistor, RC21, 0603, 1 M Ω , 5%	Phycomp	RC0603JR-071ML	FEC 9233741
R26, R72, R81, R90	Resistor, 0603, 75 k Ω , 1%	Multicomp	MC 0.063W 0603 1% 75K	FEC 9331522
R30, R39, R45, R49, R58, R67, R76, R85, R94	Resistor, 0603, 3.01 k Ω , 1%	Vishay Dale	CRCW06033K01FKEA	FEC 1469791
R9, R34, R43, R53, R62	Resistor, 0603, 300 k Ω , 1%	Multicomp	MC 0.063W 0603 1% 300K	FEC 9330992
R98, R99, R100 to R109	Resistor, 0805, 49.9 k Ω , 1%	Vishay Dale	CRCW080549K9FKEA	FEC 1469934
R97	Resistor, RC11, 0805, 0 Ω , 1%	Phycomp	9233750RL	FEC 9233750RL
S1	DPDT switch	Multicomp	6MD1S4M2RE	FEC 1550249
S2 to S5	2-way, dual-in-line switch	Grayhill	78B02T	FEC 9479031
SCL, SDA, T4 to T13	Plated hole, keep free of solder	N/A	N/A	N/A
U1, U8, U9, U10 to U15	Adjustable LDO regulator	Analog Devices	ADP3331 ARTZ	ADP3331 ARTZ
U2, U4	LDO	Analog Devices	ADP3367 ARZ	ADP3367 ARZ
U3	Diode, Zener, 27 V, 250 mW	NXP	BZX84-C27	FEC 1081413
U5	10-pin single-in-line socket terminal strip (eight 10-pin strips required)	Tyco	510-AG91D10-ESL	FEC 1172526
U6	DNP	N/A	N/A	Not assembled
U7	Voltage regulator, 3.3 V	STMicroelectronics	L78L33ACZ	FEC 1467768
VH/VH, VP1/VX4, VP2/VP1, VP3/VP2, VP4/VP3, VX1/VX1, VX2/VX2, VX3/VX3, VX4/NC, VX5/NC, X11 to X18, X29 to X32, X49, X4432, X4433	Patchwork area, not populated	N/A	N/A	N/A
X60, X61	Header, straight, 2-way	Tyco	826926-2	FEC 1248140

¹ FEC = Farnell ordering code.

NOTES

I²C refers to a communications protocol originally developed by Philips Semiconductor (now NXP Semiconductors).

**ESD Caution**

ESD (electrostatic discharge) sensitive device. Charged devices and circuit boards can discharge without detection. Although this product features patented or proprietary protection circuitry, damage may occur on devices subjected to high energy ESD. Therefore, proper ESD precautions should be taken to avoid performance degradation or loss of functionality.

Legal Terms and Conditions

By using the evaluation board discussed herein (together with any tools, components documentation or support materials, the "Evaluation Board"), you are agreeing to be bound by the terms and conditions set forth below ("Agreement") unless you have purchased the Evaluation Board, in which case the Analog Devices Standard Terms and Conditions of Sale shall govern. Do not use the Evaluation Board until you have read and agreed to the Agreement. Your use of the Evaluation Board shall signify your acceptance of the Agreement. This Agreement is made by and between you ("Customer") and Analog Devices, Inc. ("ADI"), with its principal place of business at One Technology Way, Norwood, MA 02062, USA. Subject to the terms and conditions of the Agreement, ADI hereby grants to Customer a free, limited, personal, temporary, non-exclusive, non-sublicensable, non-transferable license to use the Evaluation Board FOR EVALUATION PURPOSES ONLY. Customer understands and agrees that the Evaluation Board is provided for the sole and exclusive purpose referenced above, and agrees not to use the Evaluation Board for any other purpose. Furthermore, the license granted is expressly made subject to the following additional limitations: Customer shall not (i) rent, lease, display, sell, transfer, assign, sublicense, or distribute the Evaluation Board; and (ii) permit any Third Party to access the Evaluation Board. As used herein, the term "Third Party" includes any entity other than ADI, Customer, their employees, affiliates and in-house consultants. The Evaluation Board is NOT sold to Customer; all rights not expressly granted herein, including ownership of the Evaluation Board, are reserved by ADI. CONFIDENTIALITY. This Agreement and the Evaluation Board shall all be considered the confidential and proprietary information of ADI. Customer may not disclose or transfer any portion of the Evaluation Board to any other party for any reason. Upon discontinuation of use of the Evaluation Board or termination of this Agreement, Customer agrees to promptly return the Evaluation Board to ADI. ADDITIONAL RESTRICTIONS. Customer may not disassemble, decompile or reverse engineer chips on the Evaluation Board. Customer shall inform ADI of any occurred damages or any modifications or alterations it makes to the Evaluation Board, including but not limited to soldering or any other activity that affects the material content of the Evaluation Board. Modifications to the Evaluation Board must comply with applicable law, including but not limited to the RoHS Directive. TERMINATION. ADI may terminate this Agreement at any time upon giving written notice to Customer. Customer agrees to return to ADI the Evaluation Board at that time. LIMITATION OF LIABILITY. THE EVALUATION BOARD PROVIDED HEREUNDER IS PROVIDED "AS IS" AND ADI MAKES NO WARRANTIES OR REPRESENTATIONS OF ANY KIND WITH RESPECT TO IT. ADI SPECIFICALLY DISCLAIMS ANY REPRESENTATIONS, ENDORSEMENTS, GUARANTEES, OR WARRANTIES, EXPRESS OR IMPLIED, RELATED TO THE EVALUATION BOARD INCLUDING, BUT NOT LIMITED TO, THE IMPLIED WARRANTY OF MERCHANTABILITY, TITLE, FITNESS FOR A PARTICULAR PURPOSE OR NON-INFRINGEMENT OF INTELLECTUAL PROPERTY RIGHTS. IN NO EVENT WILL ADI AND ITS LICENSORS BE LIABLE FOR ANY INCIDENTAL, SPECIAL, INDIRECT, OR CONSEQUENTIAL DAMAGES RESULTING FROM CUSTOMER'S POSSESSION OR USE OF THE EVALUATION BOARD, INCLUDING BUT NOT LIMITED TO LOST PROFITS, DELAY COSTS, LABOR COSTS OR LOSS OF GOODWILL. ADI'S TOTAL LIABILITY FROM ANY AND ALL CAUSES SHALL BE LIMITED TO THE AMOUNT OF ONE HUNDRED US DOLLARS (\$100.00). EXPORT. Customer agrees that it will not directly or indirectly export the Evaluation Board to another country, and that it will comply with all applicable United States federal laws and regulations relating to exports. GOVERNING LAW. This Agreement shall be governed by and construed in accordance with the substantive laws of the Commonwealth of Massachusetts (excluding conflict of law rules). Any legal action regarding this Agreement will be heard in the state or federal courts having jurisdiction in Suffolk County, Massachusetts, and Customer hereby submits to the personal jurisdiction and venue of such courts. The United Nations Convention on Contracts for the International Sale of Goods shall not apply to this Agreement and is expressly disclaimed.