



Chipsmall Limited consists of a professional team with an average of over 10 year of expertise in the distribution of electronic components. Based in Hongkong, we have already established firm and mutual-benefit business relationships with customers from,Europe,America and south Asia,supplying obsolete and hard-to-find components to meet their specific needs.

With the principle of “Quality Parts,Customers Priority,Honest Operation,and Considerate Service”,our business mainly focus on the distribution of electronic components. Line cards we deal with include Microchip,ALPS,ROHM,Xilinx,Pulse,ON,Everlight and Freescale. Main products comprise IC,Modules,Potentiometer,IC Socket,Relay,Connector.Our parts cover such applications as commercial,industrial, and automotives areas.

We are looking forward to setting up business relationship with you and hope to provide you with the best service and solution. Let us make a better world for our industry!



Contact us

Tel: +86-755-8981 8866 Fax: +86-755-8427 6832

Email & Skype: info@chipsmall.com Web: www.chipsmall.com

Address: A1208, Overseas Decoration Building, #122 Zhenhua RD., Futian, Shenzhen, China



Evaluation Board for the [ADM2582E/ADM2587E](#) 2.5 kV rms Signal and Power Isolated RS-485 Transceivers with ± 15 kV ESD Protection

FEATURES

- Power and signal isolated RS-485/RS-422 transceiver
- Convenient connections for power and signal through screw terminal blocks
- Configurable as half duplex or full duplex
- 5 V or 3.3 V operation
- Easily configurable through jumper connections
- Test points for measuring all signals
- Layout optimized for emissions according to the [AN-0971 Application Note](#)
- Passed EN 55022(2001) Class B emissions standard
- Passed IEC 61000-4-5 surge testing up to 2 kV

EVALUATION KIT CONTENTS

EVAL-ADM2582EEBZ or EVAL-ADM2587EEBZ

GENERAL DESCRIPTION

The [ADM2582E/ADM2587E](#) evaluation board can be used for easy evaluation of the [ADM2582E](#) and [ADM2587E](#) power and signal isolated RS-485 transceivers. Screw terminal blocks provide convenient connections for the power and signal connections.

The evaluation board is easily configured through jumper connections. The board can be used in half-duplex or full-duplex configurations and has a 120 Ω termination resistor fitted on the receiver input. The evaluation board can be used with either the 16 Mbps [ADM2582E](#) or the 500 kbps [ADM2587E](#). The driver and receiver are enabled and disabled by jumper connections. Test points are included on the power and signal lines on both sides of the isolation barrier.

EVALUATION BOARD

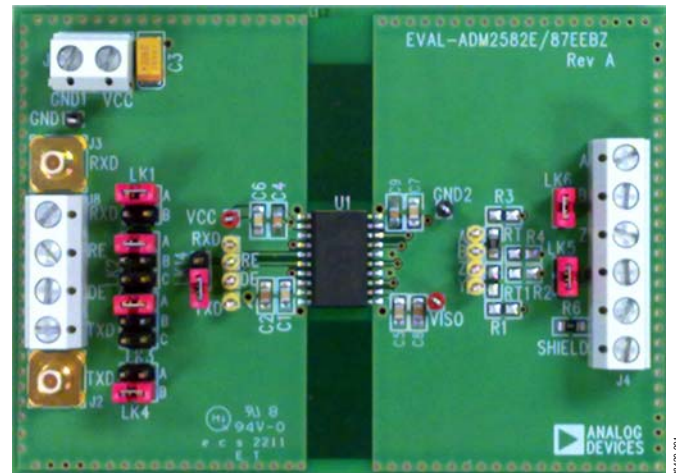

Figure 1.

RADIATED EMISSIONS

The [ADM2582E/ADM2587E](#) evaluation board is designed to reduce emissions generated by the high frequency switching elements used by the *isoPower*[®] technology to transfer power through its transformer. The layout of the evaluation board was generated using the guidelines provided in the [AN-0971 Application Note, Recommendations for Control of Radiated Emissions with isoPower Devices](#). The emissions of the evaluation board were measured by an independent test facility and passed the EN 55022(2001) Class B emissions standard.

IEC 61000-4-5 SURGE TEST

The [ADM2582E/ADM2587E](#) evaluation board was tested at an independent test facility using the circuit shown in Figure 2. The evaluation board passed the IEC 61000-4-5 surge testing up to 2 kV. The test pulses used and results of the testing are shown in Table 1.

TABLE OF CONTENTS

Features 1
 Evaluation Kit Contents..... 1
 General Description 1
 Evaluation Board 1
 Radiated Emissions 1
 IEC 61000-4-5 Surge Test 1
 Revision History 2
 IEC 61000-4-5 Surge Test Circuit and Results..... 3
 Evaluation Board Hardware Configuration 4

Jumper Settings.....4
 Termination and Pull-Up/Pull-Down Resistors5
 Decoupling and Reservoir Capacitors.....5
 Board Internal Layer Thickness5
 Evaluation Board Schematics.....6
 Assembly Drawings and Board Layout7
 Ordering Information 10
 Bill of Materials..... 10
 Related Links..... 10

REVISION HISTORY

5/12—Rev. A to Rev. B

Changes to User Guide Title, Features Section, and IEC 61000-4-5 Surge Test Section 1
 Changes to Table 1 3
 Changes to Jumper Settings Section and Table 2 4
 Changes to Decoupling and Reservoir Capacitors Section 5
 Moved Evaluation Board Schematics Section 6
 Changes to Figure 3 6
 Moved Assembly Drawings and Board Layout Section 7
 Changes to Related Links Section 10

10/11—Rev. 0 to Rev. A

Changes to User Guide Title, Features Section, and Figure 11
 Added Evaluation Kit Contents Section and IEC61000-4-5 Surge Test Section.....1
 Added IEC61000-4-5 Surge Test Circuit and Results Section, Figure 2, and Table 1; Renumbered Sequentially3
 Changes to Figure 3.....4
 Changes to LK14 Description and Image Columns, Table 2.....8
 Added Termination and Pull-Up/Pull-Down Resistors Section ...9
 Changes to Decoupling and Reservoir Capacitors Section9
 Added Ordering Guide Section, Bill of Materials Section, Table 4, and Related Links Section..... 10

11/09—Revision 0: Initial Version

IEC 61000-4-5 SURGE TEST CIRCUIT AND RESULTS

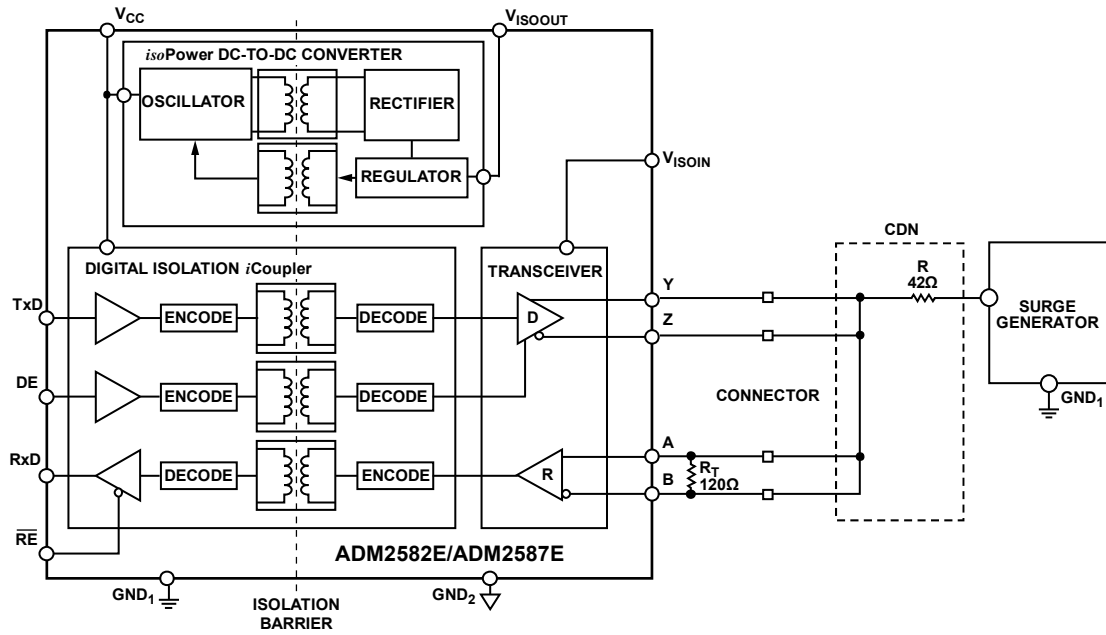

Figure 2. Block Diagram of the IEC 61000-4-5 Surge Test on the ADM2582E/ADM2587E Evaluation Board

09420-026

Table 1. Results of Surge Test to EN 61000-4-5, Passed Up to 2 kV (Test Report Available on Request at transceivers@analog.com)

Voltage (V)	Polarity	Number of Pulses	Result
260	+	1	Passed
2000	+	1	Passed



































EVALUATION BOARD HARDWARE CONFIGURATION

JUMPER SETTINGS

The inputs to the [ADM2582E/ADM2587E](#) can be configured using the jumpers on the evaluation board (see Table 2). Note that multiple jumper blocks should not be placed on LK1 to LK4 because the input sources may be shorted together.

For each link, a single jumper block can be moved from one position to another, as specified in Table 2. In addition, if LK14 is closed to connect DE and \overline{RE} , either LK2 or LK3 should be free of any jumpers to avoid shorting two input sources together.

Table 2. Jumper Configuration

Link	Connection	Description	Image
LK1	A	Connects the receiver output (Rx _D) of the ADM2582E/ADM2587E to the J3 connector.	 
	B	Connects the receiver output (Rx _D) of the ADM2582E/ADM2587E to the J8-1 terminal block connector.	 
LK2	A	Connects the receiver enable input (\overline{RE}) of the ADM2582E/ADM2587E to V _{CC} . This setting disables the receiver.	  
	B	Connects the receiver enable input (\overline{RE}) of the ADM2582E/ADM2587E to GND ₁ . This setting enables the receiver.	  
	C	Connects the receiver enable input (\overline{RE}) of the ADM2582E/ADM2587E to the J8-2 terminal block connector.	  
LK3	A	Connects the driver enable input (DE) of the ADM2582E/ADM2587E to V _{CC} . This setting enables the driver.	  
	B	Connects the driver enable input (DE) of the ADM2582E/ADM2587E to GND ₁ . This setting disables the driver.	  
	C	Connects the driver enable input (DE) of the ADM2582E/ADM2587E to the J8-3 terminal block connector.	  
LK4	A	Connects the driver input (Tx _D) of the ADM2582E/ADM2587E to the J8-4 terminal block connector.	 
	B	Connects the driver input (Tx _D) of the ADM2582E/ADM2587E to the J2 connector.	 
LK5	Closed	Connects the ADM2582E/ADM2587E Receiver Input A to Driver Output Y. When LK5 and LK6 are both closed, the evaluation board is configured for half-duplex operation.	 LK5
	Open	When LK5 and LK6 are both open, the evaluation board is configured for full-duplex operation.	 LK5
LK6	Closed	Connects the ADM2582E/ADM2587E Receiver Input B to Driver Output Z. When LK5 and LK6 are both closed, the evaluation board is configured for half-duplex operation.	 LK6
	Open	When LK5 and LK6 are both open, the evaluation board is configured for full-duplex operation.	 LK6
LK14	Closed	Connects the driver enable input (DE) of the ADM2582E/ADM2587E to the receiver enable input (\overline{RE}); that is, the input for both DE and \overline{RE} is set by LK3 (when LK2 is left open). This setting ensures that when the driver is enabled, the receiver is disabled, or that when the driver is disabled, the receiver is enabled. Note: leave either LK2 or LK3 open in all positions to avoid shorting two input sources together.	 LK14   
	Open	Disconnects the driver enable input (DE) of the ADM2582E/ADM2587E from the receiver enable input (\overline{RE}) of the ADM2582E/ADM2587E .	 LK14

TERMINATION AND PULL-UP/PULL-DOWN RESISTORS

The evaluation board includes the RT and RT1 footprints for fitting termination resistors between the A and B receiver inputs and the Y and Z driver outputs. By default, the board is fitted with a 120 Ω resistor, RT, between A and B. This resistor should be removed if the board is connected to a bus that is already terminated at both ends. For more information about proper termination, see the [AN-960 Application Note, RS-485/RS-422 Circuit Implementation Guide](#).

Although the [ADM2582E/ADM2587E](#) have a built-in receiver fail-safe for the bus idle condition, there are footprints on the evaluation board for fitting the R3 and R1 pull-up resistors to VISO on A and Y, as well as the R4 and R2 pull-down resistors to GND2 on B and Z. These resistors can be fitted if the user is connecting to other parts that require such external biasing resistors on the bus. The exact value required for a 200 mV minimum differential voltage in the bus idle condition depends on the supply voltage (for example, 960 Ω for 3.3 V and 1440 Ω for 5 V). For more information about the bus idle fail-safe, see the [AN-960 Application Note, RS-485/RS-422 Circuit Implementation Guide](#).

DECOUPLING AND RESERVOIR CAPACITORS

The evaluation board uses the following decoupling and reservoir capacitors:

- On the logic side of the board, the C1 and C2 capacitors should be 100 nF and 10 μ F ceramic capacitors, respectively, and the C4 and C6 capacitors should be 10 nF and 100 nF ceramic capacitors, respectively.
- On the bus side of the board, the C5 and C8 capacitors should be 100 nF and 10 μ F ceramic capacitors, respectively, and the C7 and C9 capacitors should be 100 nF and 10 nF ceramic capacitors, respectively.

BOARD INTERNAL LAYER THICKNESS

The [ADM2582E/ADM2587E](#) evaluation board consists of six layers with four internal layers. The spacing between the internal board layers was chosen as specified in Table 3 to maximize the stitching capacitance on the board.

Table 3. Spacing Between Layers of the Evaluation Board

Layers	Space Between Layers (mm)
1 to 2	0.1016
2 to 3	0.2032
3 to 4	0.2032
4 to 5	0.2032
5 to 6	0.1016

ASSEMBLY DRAWINGS AND BOARD LAYOUT

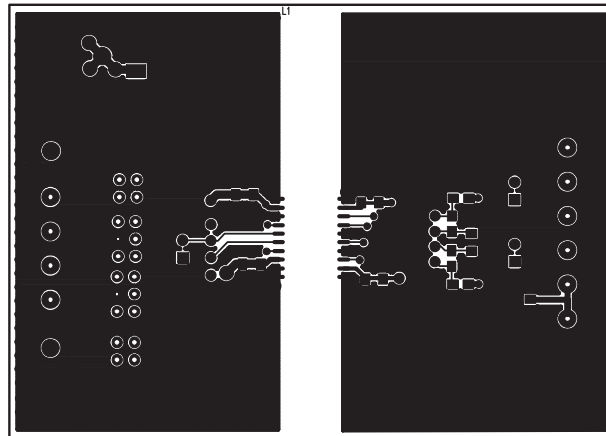

Figure 4. Top Layer

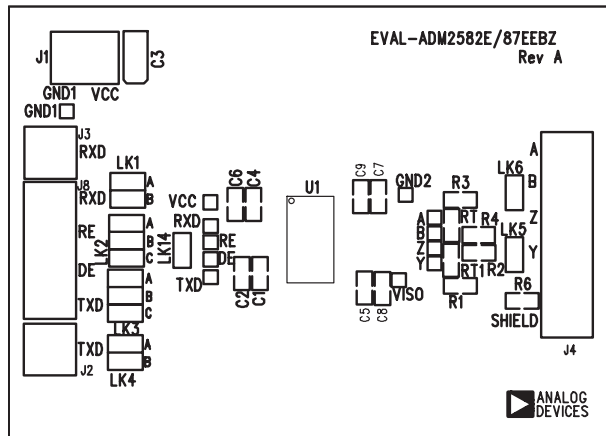

Figure 5. Silkscreen

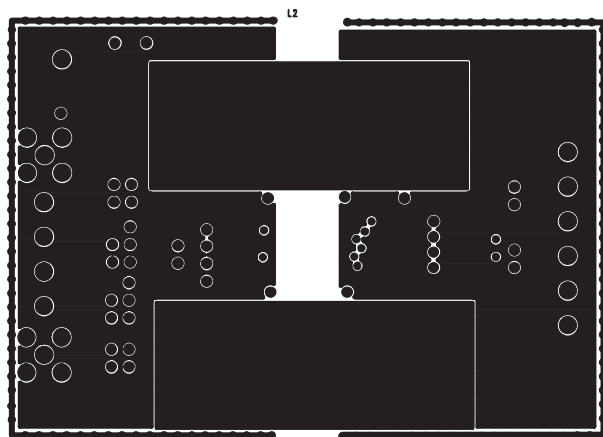

Figure 6. Internal Layer 2

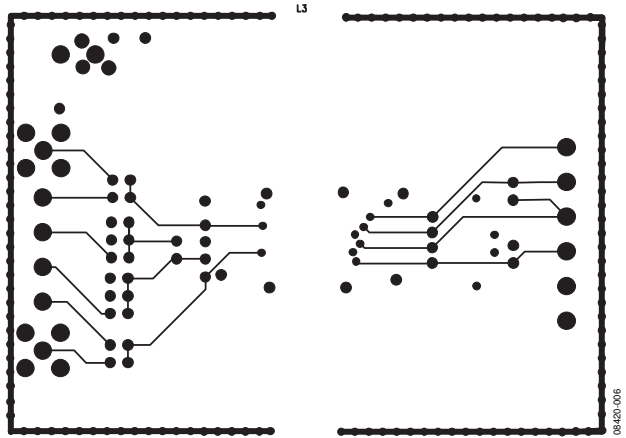

Figure 7. Internal Layer 3

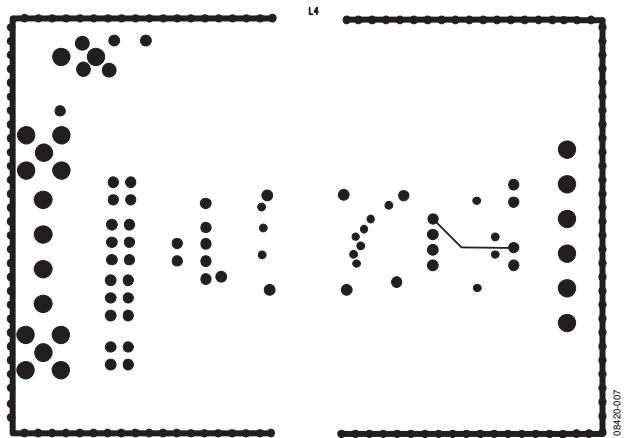

Figure 8. Internal Layer 4

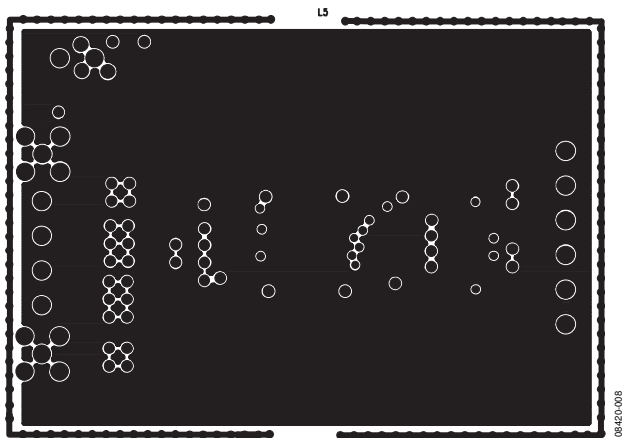

Figure 9. Internal Layer 5

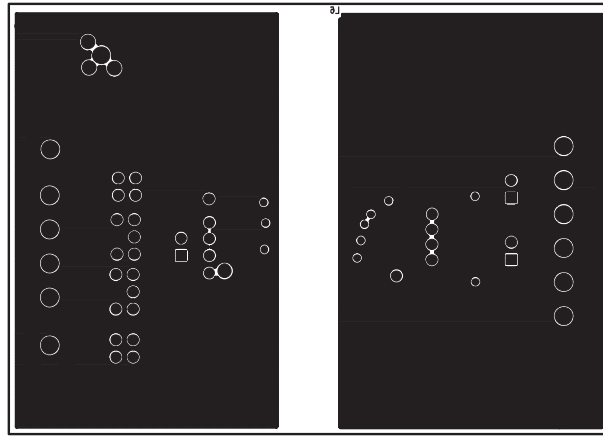

Figure 10. Bottom Solder Layer

ORDERING INFORMATION

BILL OF MATERIALS

Table 4.

Quantity	Reference Designator	Description	Supplier	Part No.
4	R1, R2, R3, R4	Resistor, size 0805 (not inserted)	Not inserted	Not inserted
1	R6	Resistor, 0 Ω , size 0805	Vishay Draloric	CRCW08050000Z0EA
1	RT	Resistor, 120 Ω , size 0805	Multicomp	MC 0.1W 0805 1%
1	RT1	Resistor, size 0805 (not inserted)	Not inserted	Not inserted
4	C1, C5, C6, C7	Capacitor, size 0805, 100 nF	Multicomp	MCCA000274
2	C2, C8	Capacitor, size 0805, 10 μ F	AVX	0805ZD106KAT2A
1	C3	Capacitor, tantalum, Case C, 22 μ F	AVX	TAJC226K016RNJ
2	C4, C9	Capacitor, size 0805, 10 nF	AVX	08053C103KAT2A
1	J1	CON\POWER2, 2-pin terminal block (5 mm pitch)	Camden Electronics	CTB5000/2
2	J2, J3	PCB SMB jack (square)	Multicomp	24-14-2-TGG
1	J4	CON\POWER6, 6-pin terminal block	Camden Electronics	CTB5000/6
1	J8	CON\POWER4, 4-pin terminal block	Camden Electronics	CTB5000/4
2	LK1, LK4	4-pin (2 \times 2), 2.54 mm header and shorting block	Harwin	M20-9953646 and M7566-05
2	LK2, LK3	6-pin (3 \times 2), 2.54 mm header and shorting block	Harwin	M20-9953646 and M7566-05
3	LK5, LK6, LK14	2-pin (1 \times 2), 2.54 mm header and shorting block	Harwin	M20-9953646 and M7566-05
1	U1	20-lead, wide-body SOIC	Analog Devices, Inc.	ADM2582EBRWZ or ADM2587EBRWZ
2	GND1, GND2	Test point, black	Vero Technologies	20-2137
2	VCC, VISO	Test point, red	Vero Technologies	20-313137
8	RXD, \overline{RE} , DE, TXD, A, B, Y, Z	Test point, yellow	Vero Technologies	20-313140

RELATED LINKS

Resource	Description
ADM2582E	16 Mbps, 2.5 kV rms Signal and Power Isolated RS-485 Transceiver with \pm 15 kV ESD Protection
ADM2587E	500 kbps, 2.5 kV rms Signal and Power Isolated RS-485 Transceiver with \pm 15 kV ESD Protection
AN-960	RS-485/RS-422 Circuit Implementation Guide
AN-0971	Recommendations for Control of Radiated Emissions with <i>iso</i> Power Devices

NOTES

NOTES

**ESD Caution**

ESD (electrostatic discharge) sensitive device. Charged devices and circuit boards can discharge without detection. Although this product features patented or proprietary protection circuitry, damage may occur on devices subjected to high energy ESD. Therefore, proper ESD precautions should be taken to avoid performance degradation or loss of functionality.

Legal Terms and Conditions

By using the evaluation board discussed herein (together with any tools, components documentation or support materials, the "Evaluation Board"), you are agreeing to be bound by the terms and conditions set forth below ("Agreement") unless you have purchased the Evaluation Board, in which case the Analog Devices Standard Terms and Conditions of Sale shall govern. Do not use the Evaluation Board until you have read and agreed to the Agreement. Your use of the Evaluation Board shall signify your acceptance of the Agreement. This Agreement is made by and between you ("Customer") and Analog Devices, Inc. ("ADI"), with its principal place of business at One Technology Way, Norwood, MA 02062, USA. Subject to the terms and conditions of the Agreement, ADI hereby grants to Customer a free, limited, personal, temporary, non-exclusive, non-sublicensable, non-transferable license to use the Evaluation Board FOR EVALUATION PURPOSES ONLY. Customer understands and agrees that the Evaluation Board is provided for the sole and exclusive purpose referenced above, and agrees not to use the Evaluation Board for any other purpose. Furthermore, the license granted is expressly made subject to the following additional limitations: Customer shall not (i) rent, lease, display, sell, transfer, assign, sublicense, or distribute the Evaluation Board; and (ii) permit any Third Party to access the Evaluation Board. As used herein, the term "Third Party" includes any entity other than ADI, Customer, their employees, affiliates and in-house consultants. The Evaluation Board is NOT sold to Customer; all rights not expressly granted herein, including ownership of the Evaluation Board, are reserved by ADI. CONFIDENTIALITY. This Agreement and the Evaluation Board shall all be considered the confidential and proprietary information of ADI. Customer may not disclose or transfer any portion of the Evaluation Board to any other party for any reason. Upon discontinuation of use of the Evaluation Board or termination of this Agreement, Customer agrees to promptly return the Evaluation Board to ADI. ADDITIONAL RESTRICTIONS. Customer may not disassemble, decompile or reverse engineer chips on the Evaluation Board. Customer shall inform ADI of any occurred damages or any modifications or alterations it makes to the Evaluation Board, including but not limited to soldering or any other activity that affects the material content of the Evaluation Board. Modifications to the Evaluation Board must comply with applicable law, including but not limited to the RoHS Directive. TERMINATION. ADI may terminate this Agreement at any time upon giving written notice to Customer. Customer agrees to return to ADI the Evaluation Board at that time. LIMITATION OF LIABILITY. THE EVALUATION BOARD PROVIDED HEREUNDER IS PROVIDED "AS IS" AND ADI MAKES NO WARRANTIES OR REPRESENTATIONS OF ANY KIND WITH RESPECT TO IT. ADI SPECIFICALLY DISCLAIMS ANY REPRESENTATIONS, ENDORSEMENTS, GUARANTEES, OR WARRANTIES, EXPRESS OR IMPLIED, RELATED TO THE EVALUATION BOARD INCLUDING, BUT NOT LIMITED TO, THE IMPLIED WARRANTY OF MERCHANTABILITY, TITLE, FITNESS FOR A PARTICULAR PURPOSE OR NON-INFRINGEMENT OF INTELLECTUAL PROPERTY RIGHTS. IN NO EVENT WILL ADI AND ITS LICENSORS BE LIABLE FOR ANY INCIDENTAL, SPECIAL, INDIRECT, OR CONSEQUENTIAL DAMAGES RESULTING FROM CUSTOMER'S POSSESSION OR USE OF THE EVALUATION BOARD, INCLUDING BUT NOT LIMITED TO LOST PROFITS, DELAY COSTS, LABOR COSTS OR LOSS OF GOODWILL. ADI'S TOTAL LIABILITY FROM ANY AND ALL CAUSES SHALL BE LIMITED TO THE AMOUNT OF ONE HUNDRED US DOLLARS (\$100.00). EXPORT. Customer agrees that it will not directly or indirectly export the Evaluation Board to another country, and that it will comply with all applicable United States federal laws and regulations relating to exports. GOVERNING LAW. This Agreement shall be governed by and construed in accordance with the substantive laws of the Commonwealth of Massachusetts (excluding conflict of law rules). Any legal action regarding this Agreement will be heard in the state or federal courts having jurisdiction in Suffolk County, Massachusetts, and Customer hereby submits to the personal jurisdiction and venue of such courts. The United Nations Convention on Contracts for the International Sale of Goods shall not apply to this Agreement and is expressly disclaimed.