



Chipsmall Limited consists of a professional team with an average of over 10 year of expertise in the distribution of electronic components. Based in Hongkong, we have already established firm and mutual-benefit business relationships with customers from,Europe,America and south Asia,supplying obsolete and hard-to-find components to meet their specific needs.

With the principle of “Quality Parts,Customers Priority,Honest Operation,and Considerate Service”,our business mainly focus on the distribution of electronic components. Line cards we deal with include Microchip,ALPS,ROHM,Xilinx,Pulse,ON,Everlight and Freescale. Main products comprise IC,Modules,Potentiometer,IC Socket,Relay,Connector.Our parts cover such applications as commercial,industrial, and automotives areas.

We are looking forward to setting up business relationship with you and hope to provide you with the best service and solution. Let us make a better world for our industry!



Contact us

Tel: +86-755-8981 8866 Fax: +86-755-8427 6832

Email & Skype: info@chipsmall.com Web: www.chipsmall.com

Address: A1208, Overseas Decoration Building, #122 Zhenhua RD., Futian, Shenzhen, China



Evaluating the ADT7310/ADT7410 Temperature Sensors

FEATURES

- Easy access to the ADT7310/ADT7410
- Connects to any PC USB port
- Self-contained evaluation system
- Test points for access to interface signals
- Secondary evaluation board allows remote temperature testing

PACKAGE CONTENTS

- ADT7310/ADT7410 evaluation board
- Secondary ADT7310/ADT7410 evaluation board
- USB cable
- CD including
 - Evaluation software
 - UG-047 user guide

PRODUCT DESCRIPTION

The ADT7310/ADT7410 evaluation board allows you to evaluate all features of the ADT7310/ADT7410 high accuracy temperature sensors. There are two boards—the main evaluation board and the secondary evaluation board—within the evaluation kit that have both the ADT7410 and ADT7310 on board.

The secondary board connects to the main board and can be used to measure temperatures that are remote from the main board while still using the evaluation software.

EVALUATION BOARD BLOCK DIAGRAMS

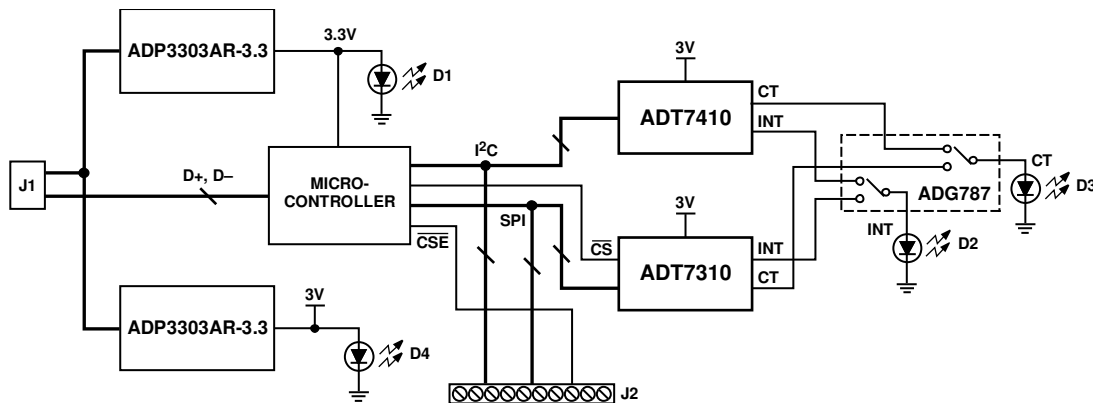

Figure 1. Main Evaluation Board

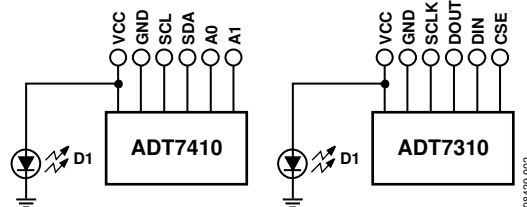

Figure 2. Secondary Evaluation Board

08429-001

08429-002

TABLE OF CONTENTS

Features	1	Connecting the Secondary Board to the Main Evaluation Board.....	4
Package Contents.....	1	Evaluation Board Software.....	5
Product Description.....	1	Installing and Running the Software	5
Evaluation Board Block Diagrams	1	Selecting the Device to Evaluate.....	5
Revision History	2	Evaluating the ADT7310/ADT7410	6
Evaluation Board	3	Configuration Register Tab.....	6
Setting Up the Evaluation Board.....	3	Temperature Monitor Tab	7
Evaluation Board Description	3	ADT7310/ADT7410 Registers Tab.....	8
Evaluation Board Hardware.....	4	Easy Setup.....	8
Connectors on the Main Board.....	4	Evaluation Board Schematics and Artwork.....	9
Connectors on the Secondary Board.....	4	ESD Caution.....	12
Indicator LEDs.....	4		

REVISION HISTORY

9/09—Revision 0: Initial Version

EVALUATION BOARD

SETTING UP THE EVALUATION BOARD

Follow these steps to set up the ADT7310/ADT7410 evaluation board:

1. Install the evaluation software from the evaluation kit CD before connecting the evaluation board to your computer. Run the file **AD7x10 Evaluation Software Install.exe**, and follow all on-screen installation instructions.
2. Plug the USB connector from the USB port on your PC into the mini-USB socket (J3) on the evaluation board. The power indicator LED on the board should illuminate.
3. Your computer will automatically associate the evaluation software with the board. The evaluation software is not digitally signed. If a message window appears during the association process, click **Continue Anyway**.
4. Ensure that all switches and links are in their default positions; Switch 3 and Switch 4 should be set to the on position.
5. Start the ADT7310/ADT7410 evaluation software.

EVALUATION BOARD DESCRIPTION

The ADT7310/ADT7410 evaluation board allows you to evaluate all features of the ADT7310/ADT7410. The board is powered via the USB connection to the host PC. The evaluation software allows data to be read from and written to the ADT7310/ADT7410. The evaluation software should be installed on your PC before the board is plugged in.

Figure 1 is a block diagram of the ADT7310/ADT7410 evaluation board, showing all the main components and how they are connected. Figure 12 and Figure 13 show the silkscreens for the evaluation board to aid in locating components on the board.

The main components on the board are the ADT7310/ADT7410 high accuracy temperature sensors, U1 and U2.

Also on the main evaluation board is a microcontroller. This microcontroller sets up and controls the ADT7310/ADT7410 over an SPI or I²C interface and takes care of the USB protocol to and from the PC.

The ADT7310/ADT7410 main evaluation board is powered via the USB connection. The V_{DD} signal goes through an ADP3303 voltage regulator (3.3 V output) before being distributed around the board. The LEDs illuminate when the board is powered.

The secondary board can be connected to the main board via Connector J2. There is one ADT7310 and one ADT7410 on the secondary board. The secondary board can be placed at some distance from the main board to easily measure the temperature of interest. There are also LEDs on the secondary board, which illuminate to indicate that the secondary board is powered.

There are connectors and test points available on all signals of interest to ensure easy accessibility.

EVALUATION BOARD HARDWARE

CONNECTORS ON THE MAIN BOARD

J1

J1 is a mini-USB socket. Connect the USB cable to this socket. The USB signals, D+ and D–, along with power and ground for the evaluation board, are connected to this socket.

J2

This connector is a 10-pin terminal block connector. It provides access to the ADT7310/ADT7410 serial interface, interrupt, and GPIO signals, as well as to the power and ground signals.

Table 1. J2 Connector Signals

J2 Pin	Signal
1	VCC
2	GND
3	SDA
4	SCL
5	A0
6	A1
7	SCLK
8	DOUT
9	DIN
10	CSE

Note that Pin 3 and Pin 4 are labeled incorrectly on the PCB; the correct pinout is listed in Table 1.

CONNECTORS ON THE SECONDARY BOARD

J1

There is no connector mounted, but connections can be made to the ADT7410 on the secondary board at this location.

Table 2. J1 Connector Signals

J1 Pin	Signal
1	VCC
2	GND
3	SCL
4	SDA
5	A0
6	A1

J3

There is no connector mounted, but connections can be made to the ADT7310 on the secondary board at this location.

Table 3. J3 Connector Signals

J3 Pin	Signal
1	VCC
2	GND
3	SCLK
4	DOUT
5	DIN
6	CSE

INDICATOR LEDS

There are four indicator LEDs on the ADT7310/ADT7410 main evaluation board and two LEDs on the secondary board. If an LED is illuminated, the corresponding signal is active.

Table 4. Indicator LEDs—Main Board

LED	Signal	Color
D1	3.3 V	Green
D2	INT	Red
D3	CT	Red
D4	3 V	Green

Table 5. Indicator LEDs—Secondary Board

LED	Signal	Color
D1	ADT7410 V _{DD}	Green
D2	ADT7310 V _{DD}	Green

CONNECTING THE SECONDARY BOARD TO THE MAIN EVALUATION BOARD

You can use the evaluation board software to evaluate the sensors on the secondary board. Connect the interfaces on Connector J1 (for the ADT7410) and Connector J3 (for the ADT7310) of the secondary interface to Connector J2 on the main evaluation board. Ensure that all communication wires are connected securely from J1 and J3 to J2 on the main board.

For the ADT7410, the A0 and A1 pins are address pins. The evaluation software assumes that the external ADT7410 has A0 connected high and A1 connected low. A0 on the secondary board must be connected directly to V_{DD} on the secondary board. Do not connect A0 from the secondary board to the main board because doing so would prevent communications between the two boards.

Note that on the main board SDA and SCL are labeled incorrectly. See Table 1 for the correct pinout of the Main Board Connector J2.

EVALUATION BOARD SOFTWARE

The evaluation software is operated in conjunction with the evaluation hardware and allows you to investigate the properties of the ADT7310/ADT7410.

INSTALLING AND RUNNING THE SOFTWARE

The software should be installed before the evaluation board is plugged into the host computer.

To install the evaluation software, run the **AD7x10 Evaluation Software Install.exe** program from the evaluation kit CD, and follow all on-screen installation instructions. The software installs by default into the **ADT7x10 Evaluation Software** directory within the **Analog Devices** folder, accessible from your **Programs** menu.

Before running the software, ensure that the evaluation board is plugged into the USB port of the host computer. Run the software from the **ADT7x10 Evaluation Software** directory.

SELECTING THE DEVICE TO EVALUATE

Select to evaluate the ADT7410 or ADT7310 (see Figure 3). The ADT7410 uses I²C communication, whereas the ADT7310 uses SPI communication with the on-board host microcontroller.

Selecting an External Part or an On-Board Part

It is possible to evaluate the on-board ADT7310/ADT7410 or to evaluate ADT7310/ADT7410 devices that are external to the main board. A secondary board is included in the evaluation kit to enable temperature testing of parts that are remote from the main board. The secondary evaluation board, or any other external ADT7310 or ADT7410 device, should be connected to the main board through Connector J2.

Click the relevant button (**On Board** or **External**) to select an on-board device or an external device to evaluate (see Figure 4).



Figure 3. ADT7x10 Evaluation Software Start-Up Window

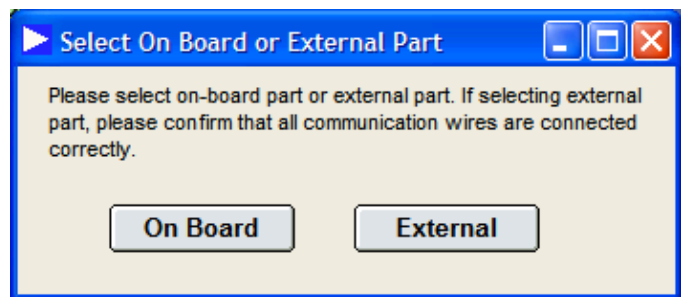

Figure 4. Select On Board or External Part Window

EVALUATING THE ADT7310/ADT7410

The evaluation software is tailored for the ADT7310 or the ADT7410, depending on which device you select in the ADT7x10 Evaluation Software Start-Up window.

CONFIGURATION REGISTER TAB

The **Configuration Register** tab, as shown in Figure 5, allows you to change the ADC resolution from 13 bits to 16 bits, to set

the operational and interrupt modes of the part, to define the number of faults in the fault queue, and to set the polarity of the CT and INT pins. See the [ADT7310](#) or [ADT7410](#) data sheet for more information on the effect of the configuration settings on the behavior of the part.

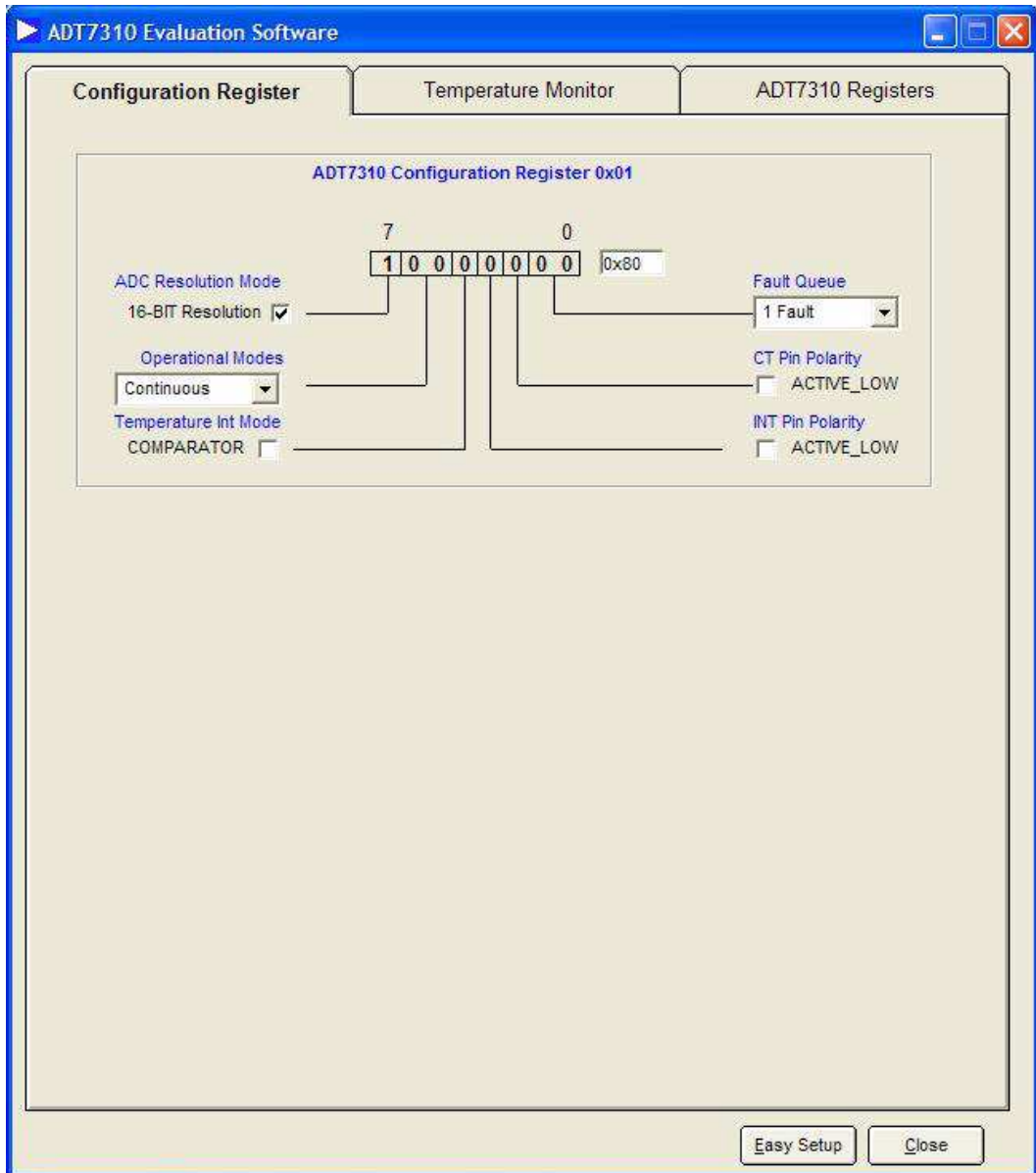

Figure 5. ADT7310 Configuration Register Tab

TEMPERATURE MONITOR TAB

The **Temperature Monitor** tab is shown in Figure 6. The current temperature from the part being evaluated is plotted in this window. Both the ADC temperature reading and the current temperature, displayed in degrees Celsius, are plotted. The high and low temperature limits are also displayed on the plots.

The **Temperature Threshold** area is labeled 1 in Figure 6. If the measured temperature goes above or below the programmed high and low limits, or above the programmed critical threshold, the corresponding button turns green.

The **Temperature Value** area, labeled 2 in Figure 6, shows the measured ADC value and the temperature value converted into degrees Celsius.

The **Set Temperature Limits** area, labeled 3 in Figure 6, allows you to update the high, low, critical, and hysteresis temperature

limits. These values are displayed as decimal ADC values. Because the conversion format from ADC code to temperature is two's complement, any value greater than 4095 corresponds to a negative temperature value. Use the arrow keys or type a number in the box to update the limits.

The **Log Data** button is labeled 4 in Figure 6. Click this button to open the window shown in Figure 7. You can log data to an Excel or text file and select whether to log the temperature as an ADC value or as a degree Celsius value, or both. The **Logging** window also allows you to set a longer logging interval than the default 50 ms.

The **Temperature Values** area, labeled 5 in Figure 6, displays the temperature and limit values in degrees Celsius. These values update automatically when you change any of the ADC values in the **Set Temperature Limits** area.

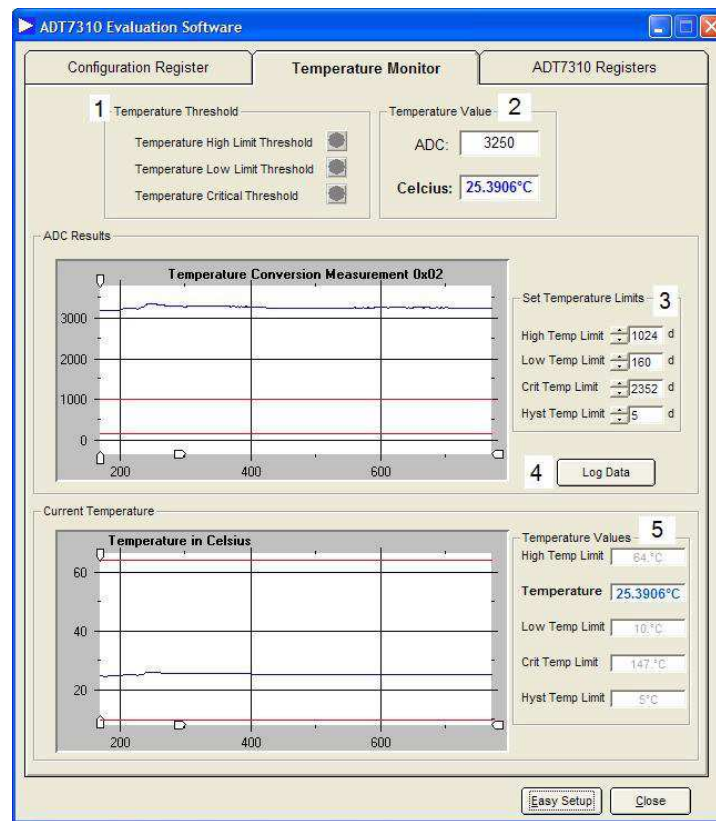

Figure 6. Temperature Monitor Tab

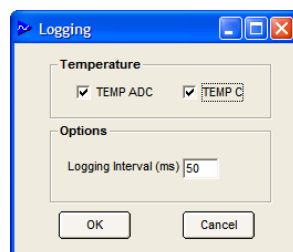

Figure 7. Logging Window

ADT7310/ADT7410 REGISTERS TAB

The **ADT7310 Registers** tab is shown in Figure 8. When evaluating the ADT7410, this tab is labeled **ADT7410 Registers**. This window displays the contents of all the on-chip registers and allows you to read to and write from these registers.

EASY SETUP

Clicking **Easy Setup** at the bottom of the **ADT7310/ADT7410 Evaluation Software** window returns the part to its original power-on state.

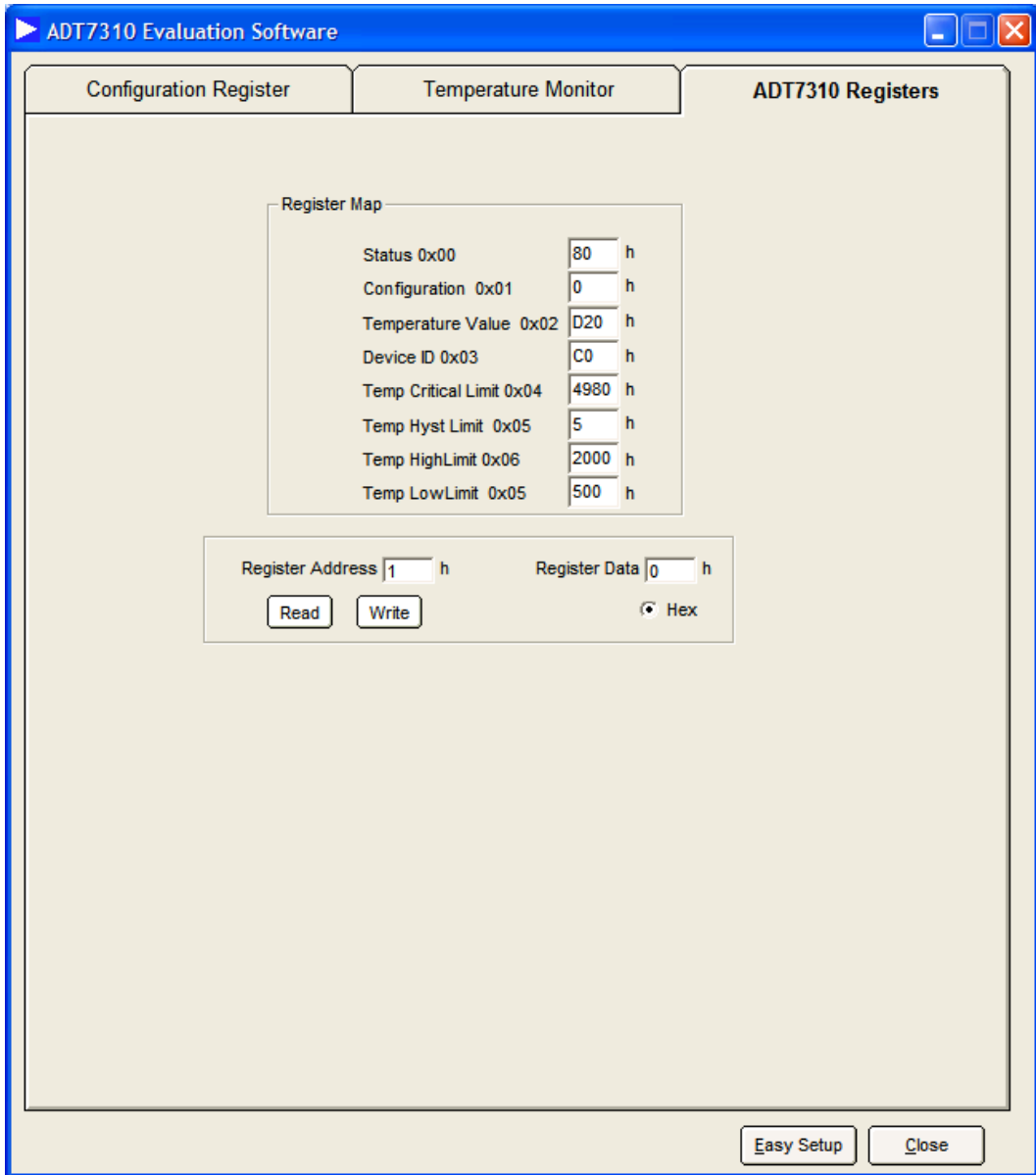

Figure 8. ADT7310 Registers

EVALUATION BOARD SCHEMATICS AND ARTWORK

600-62980

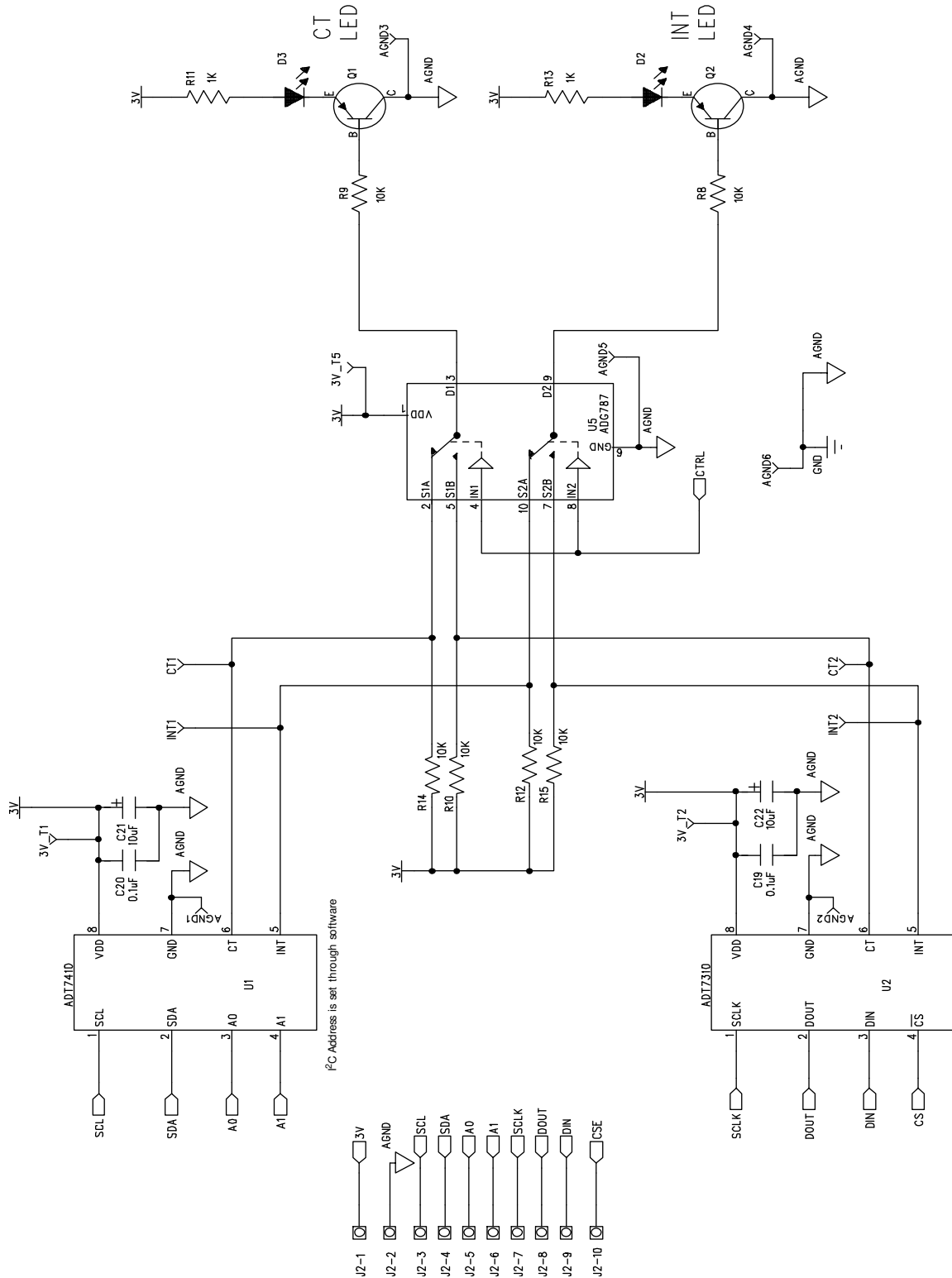

Figure 9. ADT7310/ADT7410 Main Evaluation Board Schematic, ADT7310/ADT7410 Section

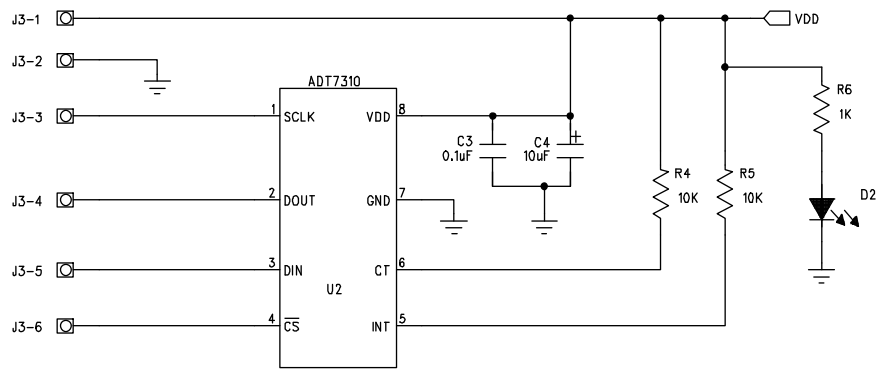
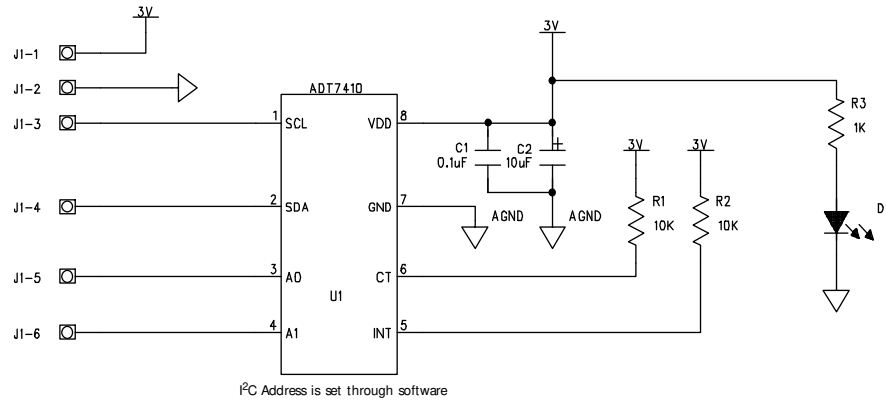

Figure 11. ADT7310/ADT7410 Secondary Evaluation Board Schematic

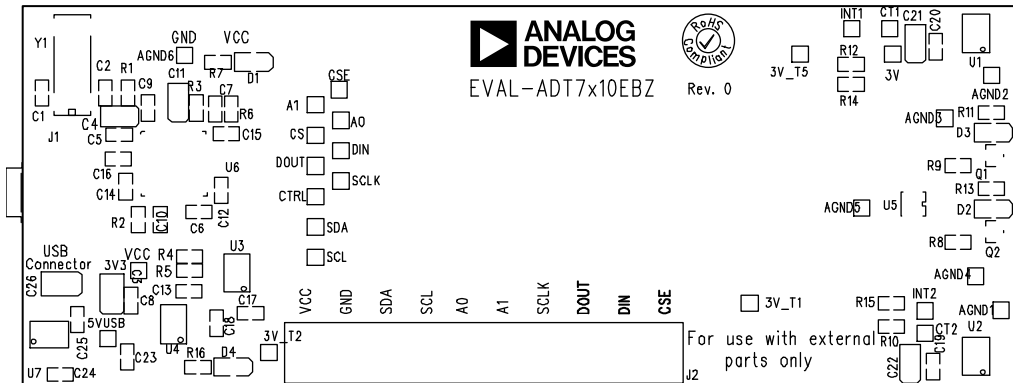

Figure 12. ADT7310/ADT7410 Main Evaluation Board Silkscreen

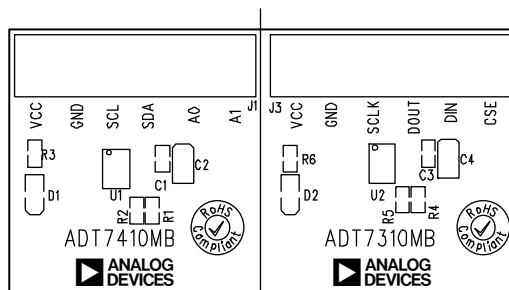

Figure 13. ADT7310/ADT7410 Secondary Evaluation Board Silkscreen

NOTES

ESD CAUTION

**ESD (electrostatic discharge) sensitive device.**

Charged devices and circuit boards can discharge without detection. Although this product features patented or proprietary protection circuitry, damage may occur on devices subjected to high energy ESD. Therefore, proper ESD precautions should be taken to avoid performance degradation or loss of functionality.

Evaluation boards are only intended for device evaluation and not for production purposes. Evaluation boards are supplied "as is" and without warranties of any kind, express, implied, or statutory including, but not limited to, any implied warranty of merchantability or fitness for a particular purpose. No license is granted by implication or otherwise under any patents or other intellectual property by application or use of evaluation boards. Information furnished by Analog Devices is believed to be accurate and reliable. However, no responsibility is assumed by Analog Devices for its use, nor for any infringements of patents or other rights of third parties that may result from its use. Analog Devices reserves the right to change devices or specifications at any time without notice. Trademarks and registered trademarks are the property of their respective owners. Evaluation boards are not authorized to be used in life support devices or systems.