



Chipsmall Limited consists of a professional team with an average of over 10 year of expertise in the distribution of electronic components. Based in Hongkong, we have already established firm and mutual-benefit business relationships with customers from,Europe,America and south Asia,supplying obsolete and hard-to-find components to meet their specific needs.

With the principle of “Quality Parts,Customers Priority,Honest Operation,and Considerate Service”,our business mainly focus on the distribution of electronic components. Line cards we deal with include Microchip,ALPS,ROHM,Xilinx,Pulse,ON,Everlight and Freescale. Main products comprise IC,Modules,Potentiometer,IC Socket,Relay,Connector.Our parts cover such applications as commercial,industrial, and automotives areas.

We are looking forward to setting up business relationship with you and hope to provide you with the best service and solution. Let us make a better world for our industry!



Contact us

Tel: +86-755-8981 8866 Fax: +86-755-8427 6832

Email & Skype: info@chipsmall.com Web: www.chipsmall.com

Address: A1208, Overseas Decoration Building, #122 Zhenhua RD., Futian, Shenzhen, China



DESCRIPTION

The EVAL-ADXL335Z is a simple evaluation board that allows quick evaluation of the performance of the [ADXL335](#) three-axis accelerometer. The EVAL-ADXL335Z has a 6-pin, 0.1 inch spaced header for access to all power and signal lines that the user can attach to a prototyping board (breadboard) or wire using a standard plug. Four holes are provided for mechanical attachment of the EVAL-ADXL335Z to the application.

The dimensions of the EVAL-ADXL335Z are 20 mm × 20 mm with mounting holes set 15 mm × 15 mm at the corners of the printed circuit board (PCB).

CIRCUIT DESCRIPTION

The schematic of the EVAL-ADXL335Z is shown in Figure 1. Analog bandwidth can be set by changing Capacitors C2, C3, and C4. See the ADXL335 data sheet for a complete description of the operation of the accelerometer.

The part layout of the EVAL-ADXL335Z is shown in Figure 2. The EVAL-ADXL335Z has four factory installed 100 nF capacitors. C1 at V_S is a bypass capacitor to reduce supply noise. C2, C3, and C4 at X_{OUT} , Y_{OUT} , and Z_{OUT} are filter capacitors to set the bandwidth to 50 Hz (see Figure 1). Many applications require a different bandwidth, in which case the user can change C2, C3, and C4 as appropriate.

SPECIAL NOTES ON HANDLING

The EVAL-ADXL335Z is not reverse polarity protected. Reversing the +V supply and ground pins can cause damage to the ADXL335.

Dropping the EVAL-ADXL335Z on a hard surface can generate several thousand gees (g) of acceleration, which may exceed the data sheet absolute maximum limits. See the ADXL335 data sheet for more information.

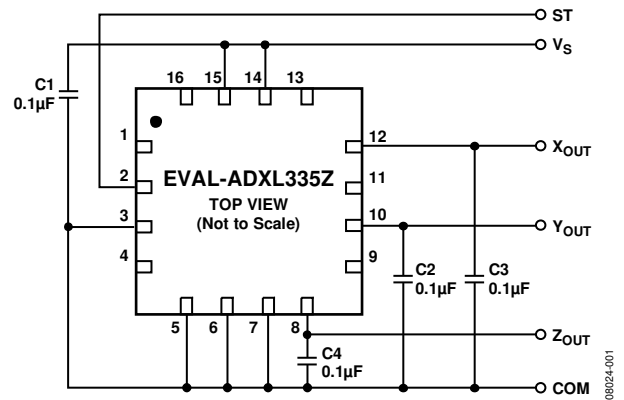

Figure 1. EVAL-ADXL335Z Schematic

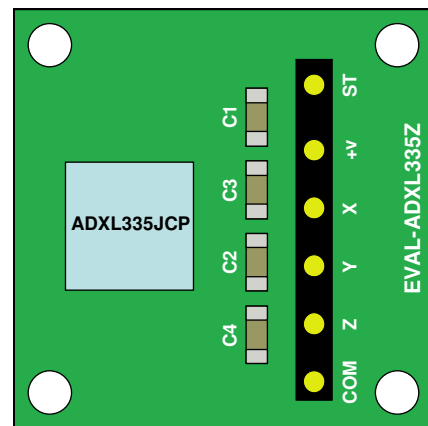

Figure 2. EVAL-ADXL335Z Physical Layout

ORDERING GUIDE

| Model | Package Description |
|----------------------------|---------------------|
| EVAL-ADXL335Z ¹ | Evaluation Board |

¹ Z = RoHS Compliant Part.

Rev. 0

Evaluation boards are only intended for device evaluation and not for production purposes. Evaluation boards are supplied "as is" and without warranties of any kind, express, implied, or statutory including, but not limited to, any implied warranty of merchantability or fitness for a particular purpose. No license is granted by implication or otherwise under any patents or other intellectual property by application or use of evaluation boards. Information furnished by Analog Devices is believed to be accurate and reliable. However, no responsibility is assumed by Analog Devices for its use, nor for any infringements of patents or other rights of third parties that may result from its use. Analog Devices reserves the right to change devices or specifications at any time without notice. Trademarks and registered trademarks are the property of their respective owners. Evaluation boards are not authorized to be used in life support devices or systems.

EVAL-ADXL335Z

NOTES