



Chipsmall Limited consists of a professional team with an average of over 10 year of expertise in the distribution of electronic components. Based in Hongkong, we have already established firm and mutual-benefit business relationships with customers from,Europe,America and south Asia,supplying obsolete and hard-to-find components to meet their specific needs.

With the principle of “Quality Parts,Customers Priority,Honest Operation,and Considerate Service”,our business mainly focus on the distribution of electronic components. Line cards we deal with include Microchip,ALPS,ROHM,Xilinx,Pulse,ON,Everlight and Freescale. Main products comprise IC,Modules,Potentiometer,IC Socket,Relay,Connector.Our parts cover such applications as commercial,industrial, and automotives areas.

We are looking forward to setting up business relationship with you and hope to provide you with the best service and solution. Let us make a better world for our industry!



## Contact us

Tel: +86-755-8981 8866 Fax: +86-755-8427 6832

Email & Skype: info@chipsmall.com Web: www.chipsmall.com

Address: A1208, Overseas Decoration Building, #122 Zhenhua RD., Futian, Shenzhen, China



## Universal Evaluation Board for Dual High Speed Op Amps Offered in 8-Lead 3 mm × 3 mm LFCSP

### FEATURES

- Enables quick breadboarding/prototyping**
- User defined circuit configuration**
- Edge mounted SMA connector provisions**
- Easy connection to test equipment and other circuits**

### GENERAL DESCRIPTION

The Analog Devices, Inc., dual LFCSP universal evaluation board is designed to help users evaluate dual high speed op amps offered in 8-lead, 3 mm × 3 mm lead frame chip scale packages (LFCSP). The dual LFCSP board is a bare board (that is, there are no components soldered to the board) that enables users to quickly prototype a variety of dual op amp circuits, which minimizes risk and reduces time to market. Figure 1 and Figure 2

show the bare evaluation board, component side and solder side, respectively.

The evaluation board is a 6-layer printed circuit board (PCB) that accepts SMA edge mounted connectors on the inputs and outputs for efficient connection to test equipment or other circuitry. The ground plane and component placement are designed to minimize parasitic inductances and capacitances. The evaluation board components are primarily SMT 0603 case size, with the exception of the electrolytic bypass capacitors (C1 and C2), which are 1206 case size.

Figure 3 shows the evaluation board schematic. Figure 4 and Figure 5 show the assembly drawing and the layout pattern of the component side, respectively. The bill of materials is listed in Table 1.

### EVALUATION BOARD LAYOUT PATTERN

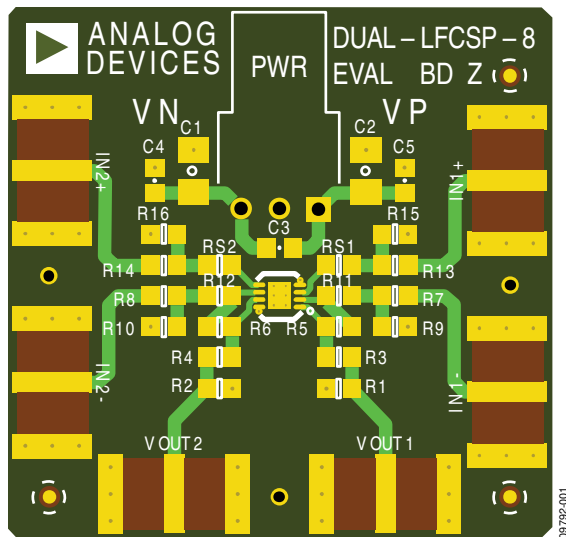

Figure 1. Evaluation Board, Component Side

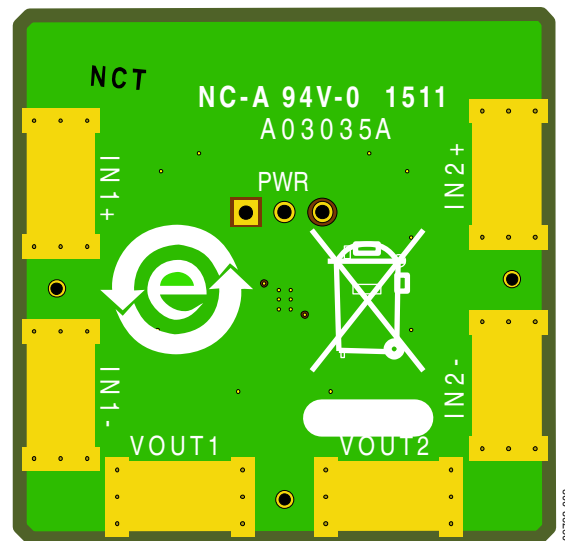

Figure 2. Evaluation Board, Solder Side

**TABLE OF CONTENTS**

|                                       |   |  |   |
|---------------------------------------|---|--|---|
| Features .....                        | 1 | Evaluation Board Schematic and Artwork.....                | 3 |
| General Description .....             | 1 | Evaluation Board Assembly Drawings and Layout Patterns ... | 3 |
| Evaluation Board Layout Pattern ..... | 1 | Ordering Information.....                                  | 4 |
| Revision History .....                | 2 | Bill of Materials.....                                     | 4 |

**REVISION HISTORY**

6/11—Revision 0: Initial Version

### EVALUATION BOARD SCHEMATIC AND ARTWORK

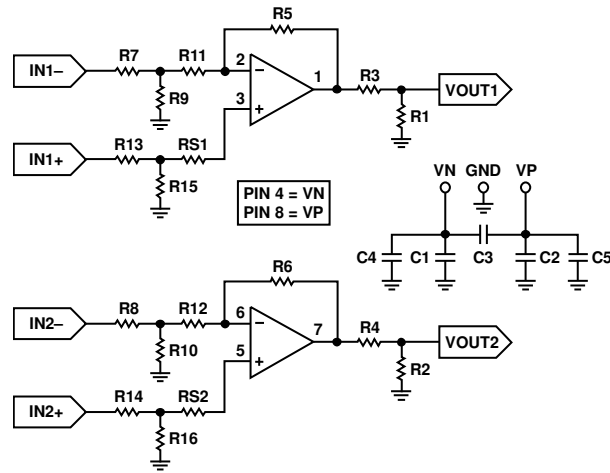

Figure 3. Dual LFCSP Evaluation Board Schematic

09792-003

### EVALUATION BOARD ASSEMBLY DRAWINGS AND LAYOUT PATTERNS

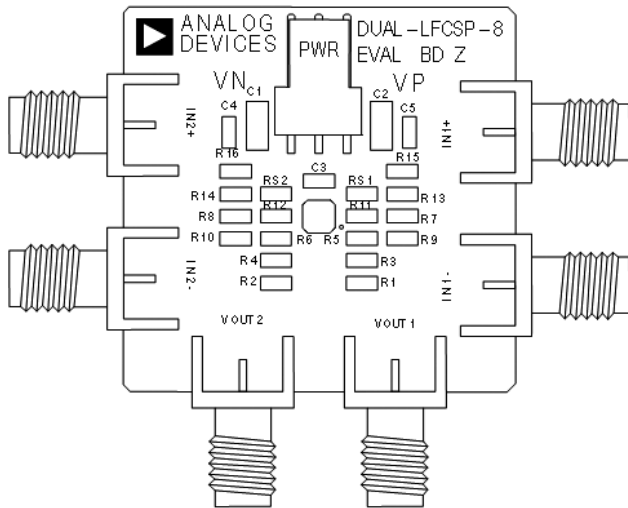

Figure 4. Component Side Assembly Drawing

09792-004

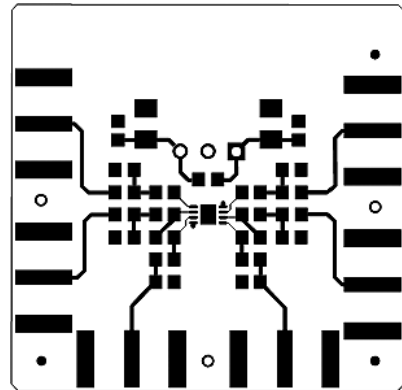

Figure 5. Component Side Layout Pattern

09792-005

## ORDERING INFORMATION

### BILL OF MATERIALS

Table 1.

| Quantity | Reference Designator                 | Description                          | Package      |
|----------|--------------------------------------|--------------------------------------|--------------|
| 3        | VP, VN, PWR                          | Test point                           | TP           |
| 2        | C1, C2                               | 10 $\mu$ F capacitor                 | 1206         |
| 3        | C3, C4, C5                           | Capacitor, user defined              | 0603         |
| 1        | DUT                                  | See data sheet packaging information | 8-lead LFCSP |
| 6        | IN1+, IN1-, IN2+, IN2-, VOUT1, VOUT2 | SMA/SMT                              | SMA/SMT      |
| 18       | R1 to R16, RS1, RS2                  | Resistor, user defined               | R0603        |



#### ESD Caution

**ESD (electrostatic discharge) sensitive device.** Charged devices and circuit boards can discharge without detection. Although this product features patented or proprietary protection circuitry, damage may occur on devices subjected to high energy ESD. Therefore, proper ESD precautions should be taken to avoid performance degradation or loss of functionality.

#### Legal Terms and Conditions

By using the evaluation board discussed herein (together with any tools, components documentation or support materials, the "Evaluation Board"), you are agreeing to be bound by the terms and conditions set forth below ("Agreement") unless you have purchased the Evaluation Board, in which case the Analog Devices Standard Terms and Conditions of Sale shall govern. Do not use the Evaluation Board until you have read and agreed to the Agreement. Your use of the Evaluation Board shall signify your acceptance of the Agreement. This Agreement is made by and between you ("Customer") and Analog Devices, Inc. ("ADI"), with its principal place of business at One Technology Way, Norwood, MA 02062, USA. Subject to the terms and conditions of the Agreement, ADI hereby grants to Customer a free, limited, personal, temporary, non-exclusive, non-sublicensable, non-transferable license to use the Evaluation Board FOR EVALUATION PURPOSES ONLY. Customer understands and agrees that the Evaluation Board is provided for the sole and exclusive purpose referenced above, and agrees not to use the Evaluation Board for any other purpose. Furthermore, the license granted is expressly made subject to the following additional limitations: Customer shall not (i) rent, lease, display, sell, transfer, assign, sublicense, or distribute the Evaluation Board; and (ii) permit any Third Party to access the Evaluation Board. As used herein, the term "Third Party" includes any entity other than ADI, Customer, their employees, affiliates and in-house consultants. The Evaluation Board is NOT sold to Customer; all rights not expressly granted herein, including ownership of the Evaluation Board, are reserved by ADI. CONFIDENTIALITY. This Agreement and the Evaluation Board shall all be considered the confidential and proprietary information of ADI. Customer may not disclose or transfer any portion of the Evaluation Board to any other party for any reason. Upon discontinuation of use of the Evaluation Board or termination of this Agreement, Customer agrees to promptly return the Evaluation Board to ADI. ADDITIONAL RESTRICTIONS. Customer may not disassemble, decompile or reverse engineer chips on the Evaluation Board. Customer shall inform ADI of any occurred damages or any modifications or alterations it makes to the Evaluation Board, including but not limited to soldering or any other activity that affects the material content of the Evaluation Board. Modifications to the Evaluation Board must comply with applicable law, including but not limited to the RoHS Directive. TERMINATION. ADI may terminate this Agreement at any time upon giving written notice to Customer. Customer agrees to return to ADI the Evaluation Board at that time. LIMITATION OF LIABILITY. THE EVALUATION BOARD PROVIDED HEREUNDER IS PROVIDED "AS IS" AND ADI MAKES NO WARRANTIES OR REPRESENTATIONS OF ANY KIND WITH RESPECT TO IT. ADI SPECIFICALLY DISCLAIMS ANY REPRESENTATIONS, ENDORSEMENTS, GUARANTEES, OR WARRANTIES, EXPRESS OR IMPLIED, RELATED TO THE EVALUATION BOARD INCLUDING, BUT NOT LIMITED TO, THE IMPLIED WARRANTY OF MERCHANTABILITY, TITLE, FITNESS FOR A PARTICULAR PURPOSE OR NON-INFRINGEMENT OF INTELLECTUAL PROPERTY RIGHTS. IN NO EVENT WILL ADI AND ITS LICENSORS BE LIABLE FOR ANY INCIDENTAL, SPECIAL, INDIRECT, OR CONSEQUENTIAL DAMAGES RESULTING FROM CUSTOMER'S POSSESSION OR USE OF THE EVALUATION BOARD, INCLUDING BUT NOT LIMITED TO LOST PROFITS, DELAY COSTS, LABOR COSTS OR LOSS OF GOODWILL. ADI'S TOTAL LIABILITY FROM ANY AND ALL CAUSES SHALL BE LIMITED TO THE AMOUNT OF ONE HUNDRED US DOLLARS (\$100.00). EXPORT. Customer agrees that it will not directly or indirectly export the Evaluation Board to another country, and that it will comply with all applicable United States federal laws and regulations relating to exports. GOVERNING LAW. This Agreement shall be governed by and construed in accordance with the substantive laws of the Commonwealth of Massachusetts (excluding conflict of law rules). Any legal action regarding this Agreement will be heard in the state or federal courts having jurisdiction in Suffolk County, Massachusetts, and Customer hereby submits to the personal jurisdiction and venue of such courts. The United Nations Convention on Contracts for the International Sale of Goods shall not apply to this Agreement and is expressly disclaimed.