



Chipsmall Limited consists of a professional team with an average of over 10 year of expertise in the distribution of electronic components. Based in Hongkong, we have already established firm and mutual-benefit business relationships with customers from,Europe,America and south Asia,supplying obsolete and hard-to-find components to meet their specific needs.

With the principle of “Quality Parts,Customers Priority,Honest Operation,and Considerate Service”,our business mainly focus on the distribution of electronic components. Line cards we deal with include Microchip,ALPS,ROHM,Xilinx,Pulse,ON,Everlight and Freescale. Main products comprise IC,Modules,Potentiometer,IC Socket,Relay,Connector.Our parts cover such applications as commercial,industrial, and automotives areas.

We are looking forward to setting up business relationship with you and hope to provide you with the best service and solution. Let us make a better world for our industry!



Contact us

Tel: +86-755-8981 8866 Fax: +86-755-8427 6832

Email & Skype: info@chipsmall.com Web: www.chipsmall.com

Address: A1208, Overseas Decoration Building, #122 Zhenhua RD., Futian, Shenzhen, China



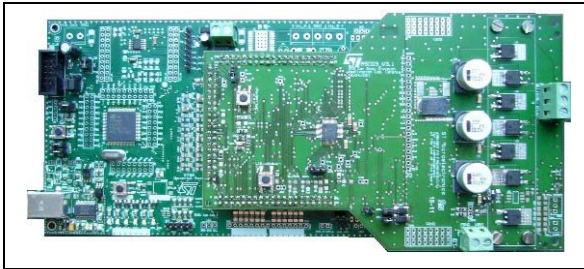

Features

- Two separated and signal shielded stages: driver & power
- ISO pulse protection (not soldered)
- Reverse polarity protection available on each battery voltage input: V_s , $VSREG$, power stage
- Current reference comparator
- PCB temperature sensor
- Hall sensors connector and conditioning circuit
- INH_wake-up button
- Microcontroller configured to be supplied by L99ASC03 5V LDO
- Flash mode configurable
- Compatible with external power boards

Description

The EVAL-L99ASC03 is an evaluation board designed for sensorless 3Phase BLDC motor control. It's composed by a mother-board and a daughter-board on which is pre-assembled the L99ASC03. The system features an enhanced power management power supply functionalities including various standby modes.

The motherboard, based on STM8 microcontroller, provides the logic section for monitoring and driving the L99ASC03 assembled in the daughterboard.

With the aim to make the board usage and settings simpler, ST provides a dedicated user-friendly software with a Graphic User Interface (GUI). This enables the user to set L99ASC03 parameters and at the same time it shows real time device information as the current evolution, motor speed (RPM), the fault flags, the board temperature and much more.

Table 1. Device summary

Order code	Reference
EVAL-L99ASC03	L99ASC03 evaluation board

Contents

- 1 Demonstration software 3**
 - 1.1 System requirements 3

- Appendix A Application schematics and layouts 4**
 - A.1 L99ASC03 daughterboard. 4

- Revision history 6**

1 Demonstration software

A software GUI (Graphical User Interface) for easy demonstration of the L99ASC03 is available on www.st.com.

1.1 System requirements

- Windows OS (XP, 7, 8)
- USB type B

Figure 3. EVAL-L99ASC03 schematic

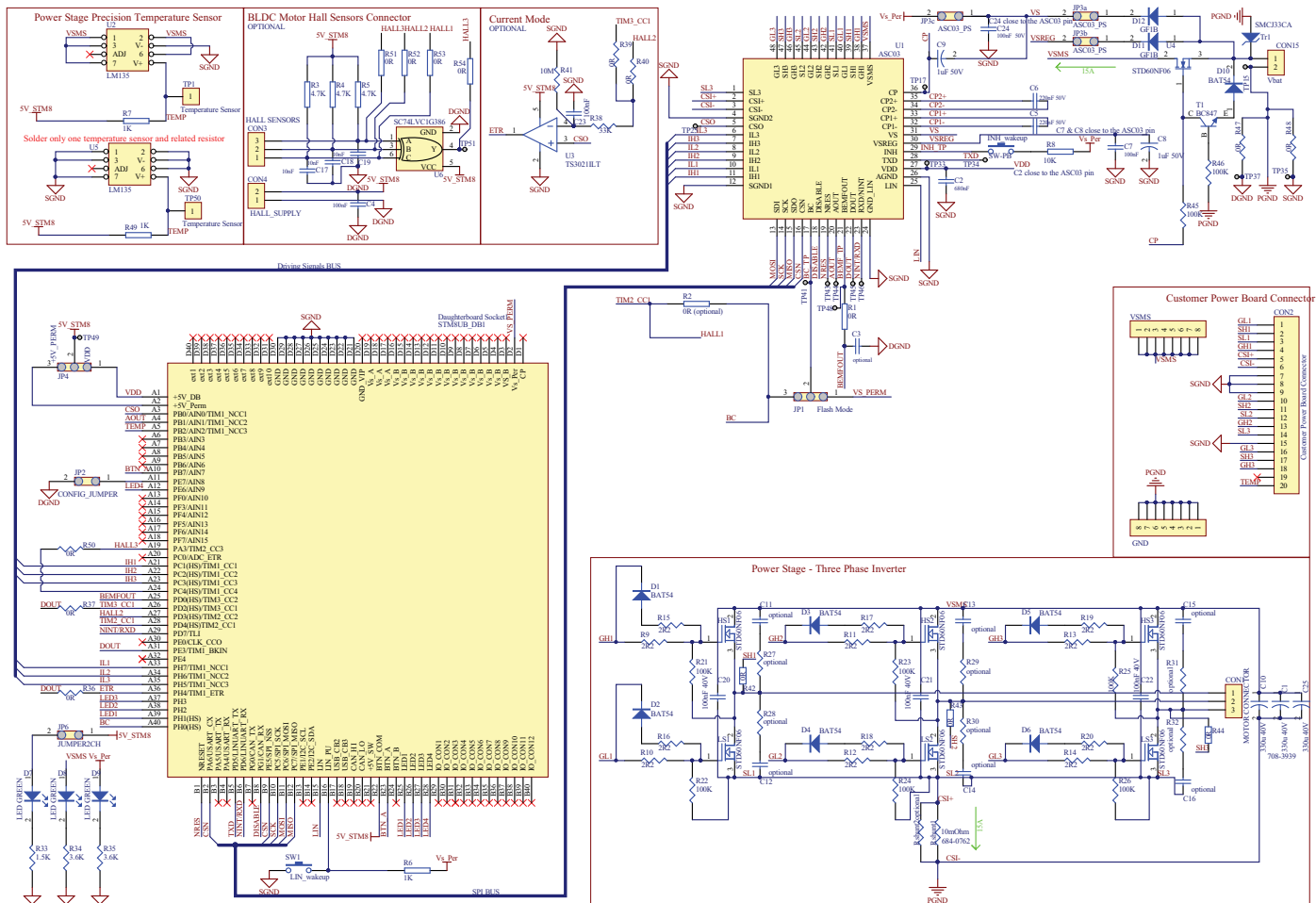

Revision history

Table 2. Document revision history

Date	Revision	Changes
14-Dec-2017	1	Initial release.

IMPORTANT NOTICE – PLEASE READ CAREFULLY

STMicroelectronics NV and its subsidiaries ("ST") reserve the right to make changes, corrections, enhancements, modifications, and improvements to ST products and/or to this document at any time without notice. Purchasers should obtain the latest relevant information on ST products before placing orders. ST products are sold pursuant to ST's terms and conditions of sale in place at the time of order acknowledgement.

Purchasers are solely responsible for the choice, selection, and use of ST products and ST assumes no liability for application assistance or the design of Purchasers' products.

No license, express or implied, to any intellectual property right is granted by ST herein.

Resale of ST products with provisions different from the information set forth herein shall void any warranty granted by ST for such product.

ST and the ST logo are trademarks of ST. All other product or service names are the property of their respective owners.

Information in this document supersedes and replaces information previously supplied in any prior versions of this document.

© 2017 STMicroelectronics – All rights reserved