



Chipsmall Limited consists of a professional team with an average of over 10 year of expertise in the distribution of electronic components. Based in Hongkong, we have already established firm and mutual-benefit business relationships with customers from,Europe,America and south Asia,supplying obsolete and hard-to-find components to meet their specific needs.

With the principle of “Quality Parts,Customers Priority,Honest Operation,and Considerate Service”,our business mainly focus on the distribution of electronic components. Line cards we deal with include Microchip,ALPS,ROHM,Xilinx,Pulse,ON,Everlight and Freescale. Main products comprise IC,Modules,Potentiometer,IC Socket,Relay,Connector.Our parts cover such applications as commercial,industrial, and automotives areas.

We are looking forward to setting up business relationship with you and hope to provide you with the best service and solution. Let us make a better world for our industry!



## Contact us

Tel: +86-755-8981 8866 Fax: +86-755-8427 6832

Email & Skype: info@chipsmall.com Web: www.chipsmall.com

Address: A1208, Overseas Decoration Building, #122 Zhenhua RD., Futian, Shenzhen, China



CLASSIFICATION	PRODUCT SPECIFICATION	No. DS-4561-2400-102	REV. G
SUBJECT	MODEM FOR 802.15.4 IEEE STANDARD	PAGE 1 of 34	
CUSTOMER'S CODE PAN4561H /M /L	PANASONIC PART NUMBER ENWC9A22xxEF / .25xx. / .21xx.	DATE 06.08.2010	

## Product Specification

Applicant / Manufacturer Hardware	Panasonic Electronic Devices Europe GmbH Zeppelinstrasse 19 21337 Lüneburg Germany	
Applicant / Manufacturer Software	Synapse Wireless Inc. SNAP Software E-Senza Technologies GmbH SN55 AT Command Set Freescale based SMAC test software for production your own written software	or or or
Software Version Contents	Approval from customer by signature	
Customer		

By signing this document, you acknowledge that you are the legal representative for your company and that you understand and accept the validity of the contents herein.

CHECKED / APPROVED:

DATE:	NAME:	SIGNATURE:

NOTE:

AT LEAST ONE SET OF APPROVED SPECIFICATIONS SHOULD BE RETURNED TO THE ADDRESS OF THE ISSUING PARTY.

CLASSIFICATION	PRODUCT SPECIFICATION	No. DS-4561-2400-102	REV. G
SUBJECT	MODEM FOR 802.15.4 IEEE STANDARD	PAGE 2 of 34	
CUSTOMER'S CODE PAN4561H /M /L	PANASONIC PART NUMBER ENWC9A22xxEF / .25xx. / .21xx.	DATE 06.08.2010	

## TABLE OF CONTENTS

1.	Key Features .....	4
2.	Applications for the Module .....	4
3.	Description of the Module.....	5
4.	Scope of this Document .....	6
5.	History for this Document .....	6
6.	Terminal Layout.....	7
7.	Block diagram.....	9
	7.1. Software differences .....	10
	7.1.1. Test / Demo software .....	10
	7.1.2. E-Senza software.....	10
	7.1.3. Synapse software .....	10
8.	Key Parts List .....	11
9.	Test Conditions .....	11
10.	Absolut maximum ratings .....	12
11.	Operating Conditions.....	12
12.	DC electrical characeristics .....	13
13.	A/D converter Characteristics.....	14
14.	AC Electrical Characteristics .....	14
15.	Soldering Temperature - Time Profile (for reflow soldering) .....	16
	15.1. For lead solder .....	16
	15.2. For lead free solder .....	16
16.	Module Dimensions.....	17
17.	FootPrint of the Module .....	17
18.	Laser marking.....	18
19.	Mechanical Requirements.....	18
20.	Recommended Land Pattern .....	19
21.	Reliability Tests .....	20
22.	Cautions .....	20
	22.1. Design Notes.....	20
	22.2. Installation Notes.....	20
	22.3. Usage Conditions Notes .....	21
	22.4. Storage Notes .....	22
	22.5. Safety Cautions.....	22
	22.6. Other cautions.....	22
23.	Packaging.....	24
	23.1. Tape Dimension .....	24
	23.2. Packing in Tape .....	24
	23.3. Component direction .....	25
	23.4. Reel Dimension.....	25

CLASSIFICATION	PRODUCT SPECIFICATION	No. DS-4561-2400-102	REV. G
SUBJECT	MODEM FOR 802.15.4 IEEE STANDARD	PAGE 3 of 34	
CUSTOMER'S CODE PAN4561H /M /L	PANASONIC PART NUMBER ENWC9A22xxEF / .25xx. / .21xx.	DATE 06.08.2010	

23.5. Label for Package .....	26
23.6. Total Packing Handling .....	27
23.7. Cover tape reel strength.....	27
24. Ordering Information .....	28
24.1. PAN4561H .....	28
24.2. PAN4561M.....	29
24.3. PAN4561L.....	29
25. RoHS Declaration.....	30
26. Data Sheet Status .....	30
27. Regulatory Information .....	30
27.1. FCC Notice.....	30
27.2. Caution.....	31
27.3. Labeling Requirements .....	31
27.4. Antenna Warning .....	31
27.5. Approved Antenna List.....	32
27.6. RF Exposure PAN4561.....	32
28. Related Documents .....	33
29. General Information.....	34
30. Life Support Policy .....	34

CLASSIFICATION	PRODUCT SPECIFICATION	No. DS-4561-2400-102	REV. G
SUBJECT	MODEM FOR 802.15.4 IEEE STANDARD	PAGE 4 of 34	
CUSTOMER'S CODE PAN4561H /M /L	PANASONIC PART NUMBER ENWC9A22xxEF / .25xx. / .21xx.	DATE 06.08.2010	

## 1. KEY FEATURES

- Short range 2.4GHz ISM band transceiver with microcontroller and reference oscillator
- Provides complete hardware for a wireless node using IEEE802.15.4 packet structure
- Compact size (35.0mm x 15.0mm x 3.8mm)
- 3 antenna options: ceramic antenna onboard, ext. antenna connected to Single port 50Ω or antenna plug
- 16 selectable Channels with 250 kbps in the 2.4 GHz band
- Low power modes for increased battery life
- High sensitivity of -102 dBm typ. at 1% Packet Error Rate (PAN4561H /M)
- +20 dBm max. output power (PAN4561H)
- Programmable output power over a 30 dB range
- Low supply voltage (2.7V to 3.4 V, 3.0 V typ.)
- Operating temperature range -40°C to +85°C
- Link Quality and Clear Channel Assessment capability
- 60k Flash and 4k RAM memory
- 8 channel A/D converter with 10 Bit for fast and easy conversion from analog inputs -such as temperature, pressure and fluid levels- to digital values.
- 5 channel 16 Bit timer/pulse width modulation (TPM) outputs
- BDM port for direct download programming
- In total 39 digital I/O lines most with programmable pull-ups and few with high-current driver.
- Low power modes for increased battery life
- Low battery warning
- Low voltage detect/reset
- Complies to FCC Part 15

## 2. APPLICATIONS FOR THE MODULE

- Wireless sensor and actuator networks
- Remote control and wire replacement in industrial systems
- Factory and home automation and control
- Inventory and logistics management
- HID (Human Interface Devices)
- Toys
- Home gateways
- Proprietary networking solutions using IEEE802.15.4

CLASSIFICATION	PRODUCT SPECIFICATION	No. DS-4561-2400-102	REV. G
SUBJECT	MODEM FOR 802.15.4 IEEE STANDARD	PAGE 5 of 34	
CUSTOMER'S CODE PAN4561H /M /L	PANASONIC PART NUMBER ENWC9A22xxEF / .25xx. / .21xx.	DATE 06.08.2010	

### 3. DESCRIPTION OF THE MODULE

The PAN4561with module is a short range, low power, 2.4 GHz ISM band transceiver which includes a complete 802.15.4 physical layer (PHY) modem, designed for the IEEE 802.15.4 wireless standard and an appropriate microcontroller (MCU) with reference oscillator which provides a cost effective solution for short-range data links and networks.

There are three versions of PAN4561 available, identified by an H, M or L at the end of series number i.e. PAN4561H, PAN4561M, PAN4561L. The additional letter stands for High, Mid and Low range.

All modules in the PAN4561 series are based on the FreeScale MC13213 SOC, fully featured with 39 I/O lines, interchangeable and share a common footprint and software. Mixed node networks can be implemented to conserve power while maximizing range. The PAN4561L is a cost optimized module designed for standard range applications of less than 30 meters. For medium range applications the PAN4561M, is optimized to deliver longer range and conserve power consumption, using a low noise amplifier and 10dBm power amplifier. The PAN4561H is designed for extended range applications, using a low noise amplifier and 20dBm power amplifier.

In this document when mentioned PAN4561 the information refers to all three module types. Data which apply only to a specific module (PAN4561 H /M /L) will be marked accordingly.

Software solutions available for the PAN4561 are SNAP software from Synapse Wireless Inc. and SN55 software from E-Senza Technologies GmbH which are very easy to use. For detailed information refer to SNAP [9] and and to SN55 [8].

In addition, you are free to develop also your own application on the software package from Freescale™, e.g. SMAC, for details please refer to [4], [5], [6] and [7].

For the Integrated Development Environment (IDE) the Metrowerks™ CodeWarrior IDE from [www.metrowerks.com](http://www.metrowerks.com) is required. For device flash programming via the BDM port of PAN4561 the USB HCS08/HCS12 Multilink from [www.pemicro.com](http://www.pemicro.com) is recommended.

CLASSIFICATION	PRODUCT SPECIFICATION	No. DS-4561-2400-102	REV. G
SUBJECT	MODEM FOR 802.15.4 IEEE STANDARD	PAGE 6 of 34	
CUSTOMER'S CODE PAN4561H /M /L	PANASONIC PART NUMBER ENWC9A22xxEF / .25xx. / .21xx.	DATE 06.08.2010	

#### 4. SCOPE OF THIS DOCUMENT

This product specification applies to the IEEE 802.15.4 Standard modem ENWC9A22xxEF. The xx is the indicator for different versions (refer to chapter 25 Ordering Information). The platform used is the MC13213 from the US company Freescale Semiconductor [www.freescale.com/](http://www.freescale.com/) [2], [3]

#### 5. HISTORY FOR THIS DOCUMENT

Revision	Date	Modification / Remarks
A	09.03.2009	Initial draft version
B	20.03.2009	Some minor changes, regarding the specification wording
C	29.04.2009	Change chapter 24, ordering code for Synapse software. Change the crystal value from 26MHz to 16MHz in chapter block diagram, as it was a mistake in this document.
D	08.09.2009	Change chapter 7, regarding hardware dependent software.
E	06.04.2010	Datasheet updated for 4561 PCB revision C (Preliminary)
F	31.05.2010	Added chapter 27 Regulatory Information. Minor changes of module parameters.
G	06.08.2010	Added data for PAN4561M and PAN4561L

CLASSIFICATION	PRODUCT SPECIFICATION	No. DS-4561-2400-102	REV. G
SUBJECT	MODEM FOR 802.15.4 IEEE STANDARD	PAGE 7 of 34	
CUSTOMER'S CODE PAN4561H /M /L	PANASONIC PART NUMBER ENWC9A22xxEF / .25xx. / .21xx.	DATE 06.08.2010	

## 6. TERMINAL LAYOUT

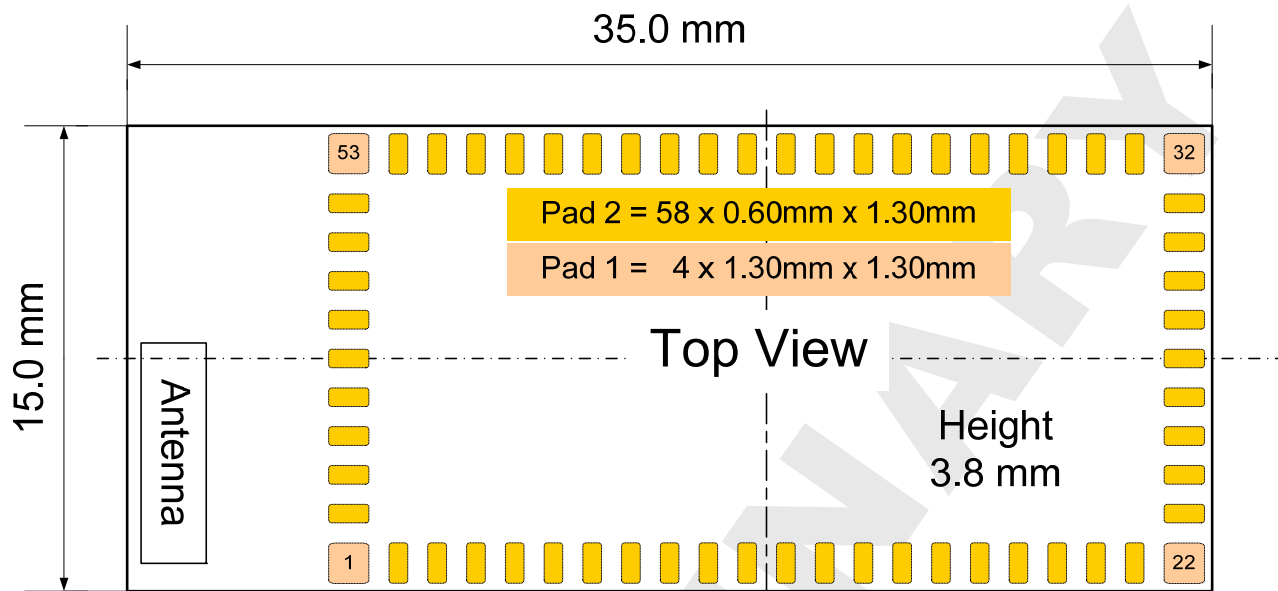

Please refer also to the MC1321x technical data sheet and reference manual, which is given in [2] and [3] in the chapter "Related Documents".

Pin No.	Pin	Pin Type	Description
1	GND	I/O	Ground
2	PTD4 / TPM2CH1	Dig. I/O	MCU Port D Bit 4 / TPM2 Channel 1
3	PTD5 / TPM2CH2	Dig. I/O	MCU Port D Bit 5 / TPM2 Channel 2
4	PTD6 / TPM2CH3	Dig. I/O	MCU Port D Bit 6 / TPM2 Channel 3
5	PTD7 / TPM2CH4	Dig. I/O	MCU Port D Bit 7 / TPM2 Channel 4
6	PTD2 / TPM1CH2	Dig. I/O	MCU Port D Bit 2 / TPM1 Channel 2
7	NC		Not connected – leave open
8	PTC0 / TXD2	Dig. I/O	MCU Port C Bit 0 / SCI2 TX data out (UART2)
9	PTC1 / RXD2	Dig. I/O	MCU Port C Bit 1 / SCI2 RX data in (UART2)
10	PTC2 / SDA1	Dig. I/O	MCU Port C Bit 1/ IIC bus data (I <sup>2</sup> C)
11	PTC3 / SCL1	Dig. I/O	MCU Port C Bit 1/ IIC bus clock (I <sup>2</sup> C)
12	PTB0 / AD1P0	I/O	MCU Port B Bit 0 / ATD analog Channel 0
13	PTB1 / AD1P1	I/O	MCU Port B Bit 1 / ATD analog Channel 1
14	PTB2 / AD1P2	I/O	MCU Port B Bit 2 / ATD analog Channel 2
15	PTB3 / AD1P3	I/O	MCU Port B Bit 3 / ATD analog Channel 3
16	PTB4 / AD1P4	I/O	MCU Port B Bit 4 / ATD analog Channel 4
17	PTB5 / AD1P5	I/O	MCU Port B Bit 5 / ATD analog Channel 5
18	PTB6 / AD1P6	I/O	MCU Port B Bit 6 / ATD analog Channel 6
19	PTB7 / AD1P7	I/O	MCU Port B Bit 7 / ATD analog Channel 7
20	VREFH	I	MCU high reference voltage for ATD
21	VREFL	I	MCU low reference voltage for ATD
22	GND	I/O	Ground
23	Vcc	Power I	Modem voltage regulators' input
24	Vcc	Power I	Modem voltage regulators' input
25	PTG1 / XTAL	Dig. I/O / O	MCU Port G Bit 1 / Crystal oscillator output <sup>(2)</sup>



CLASSIFICATION	PRODUCT SPECIFICATION	No. DS-4561-2400-102	REV. G
SUBJECT	MODEM FOR 802.15.4 IEEE STANDARD	PAGE 8 of 34	
CUSTOMER'S CODE PAN4561H /M /L	PANASONIC PART NUMBER ENWC9A22xxEF / .25xx. / .21xx.	DATE 06.08.2010	

Pin No.	Pin	Pin Type	Description
26	PTG2 / EXTAL	Dig. I/O / I	MCU Port G Bit 2 / Crystal oscillator input <sup>(2)</sup> <sup>(3)</sup> <sup>(4)</sup>
27	RESET	Dig. I	MCU reset. Active low
28	CLKO	Dig. O	Programmable Clock Output (default: 32,768 kHz) <sup>(3)</sup>
29	GPIO2	Dig. I/O	GPIO2 from RF transceiver unit
30	PTG0 / BKGND / MS	Dig. I/O	MCU Port G Bit 0 / Background / Mode Select <sup>(1)</sup>
31	GPIO1	Dig. I/O	GPIO1 from RF transceiver unit
32	GND	I/O	Ground
33	VDDA	Power O	Modem analog regulated supply output - leave open
34	PTA7 / KBI1P7	Dig. I/O	MCU Port A Bit 7 / Keyboard Input Bit 7
35	PTA6 / KBI1P6	Dig. I/O	MCU Port A Bit 6 / Keyboard Input Bit 6
36	PTA5 / KBI1P5	Dig. I/O	MCU Port A Bit 5 / Keyboard Input Bit 5
37	PTA4 / KBI1P4	Dig. I/O	MCU Port A Bit 4 / Keyboard Input Bit 4
38	PTA3 / KBI1P3	Dig. I/O	MCU Port A Bit 3 / Keyboard Input Bit 3
39	PTA2 / KBI1P2	Dig. I/O	MCU Port A Bit 2 / Keyboard Input Bit 2
40	PTA1 / KBI1P1	Dig. I/O	MCU Port A Bit 1 / Keyboard Input Bit 1
41	PTA0 / KBI1P0	Dig. I/O	MCU Port A Bit 0 / Keyboard Input Bit 0
42	PTC7 / GPIO	Dig. I/O	MCU Port C Bit 7 (GPIO)
43	PTC6 / GPIO	Dig. I/O	MCU Port C Bit 6 (GPIO)
44	PTC5 / GPIO	Dig. I/O	MCU Port C Bit 5 (GPIO)
45	PTC4 / GPIO	Dig. I/O	MCU Port C Bit 4 (GPIO)
46	PTE0 / TXD1	Dig. I/O	MCU Port E Bit 0 / SCI1 TX data out (UART1)
47	PTE1 / RXD1	Dig. I/O	MCU Port E Bit 1/ SCI1 RX data in (UART1)
48	GPIO5	Dig. I/O	GPIO5 from RF transceiver unit
49	GPIO6	Dig. I/O	GPIO6 from RF transceiver unit
50	GPIO7	Dig. I/O	GPIO7 from RF transceiver unit
51	NC		Not connected – leave open
52	NC		Not connected – leave open
53 - 54	GND	I/O	Ground
55	EXANT	I/O	Pin for external antenna (50 Ω)
56 - 62	GND	I/O	Ground

Note:

- (1) PTG0 is output only. Pin is I/O when used as BDM function.
- (2) Full I/O when not used as clock source. Please refer also to [2].
- (3) CLKO (Pin 28) and PTG2/EXTAL (Pin 26) must be connected when the programmable clock derived from the internal 16 MHz crystal.  
Do not connect when the clock derived from Internal Reference Generator in MC13213.
- (4) PTG2 / EXTAL is not accessible with E-Senza software

Port PTA, PTB, PTC, PTD, PTE, PTG have internal software controlled pull-up resistors. For detailed information refer to [3].

All I/O pins of port PTC are high current pins. The maximum current for all pins together must not exceed 60mA. A continuous current of 7mA, and 25mA burst for each port pin must not be exceeded. For detailed information refer to [3].

CLASSIFICATION	PRODUCT SPECIFICATION	No. DS-4561-2400-102	REV. G
SUBJECT	MODEM FOR 802.15.4 IEEE STANDARD	PAGE 9 of 34	
CUSTOMER'S CODE PAN4561H / M / L	PANASONIC PART NUMBER ENWC9A22xxEF / .25xx. / .21xx.	DATE 06.08.2010	

## 7. BLOCK DIAGRAM

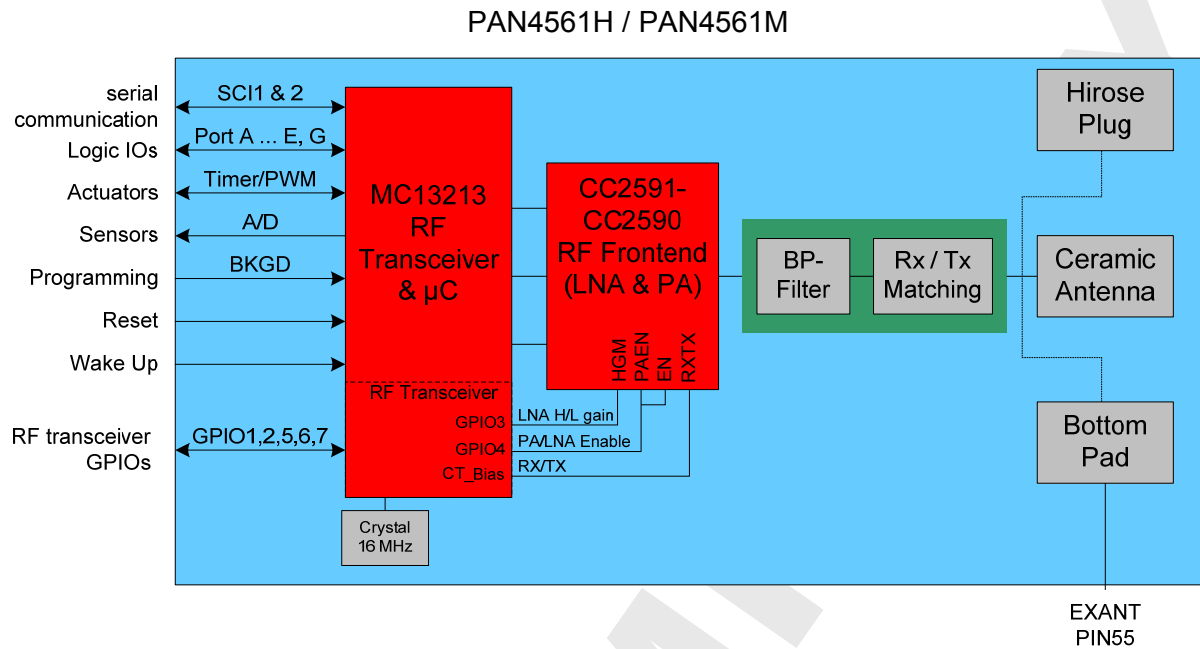

The RF frontend IC CC2591 / CC2590 is controlled with GPIO3, GPIO4 and CT\_Bias from RF transceiver unit (see above block diagram).

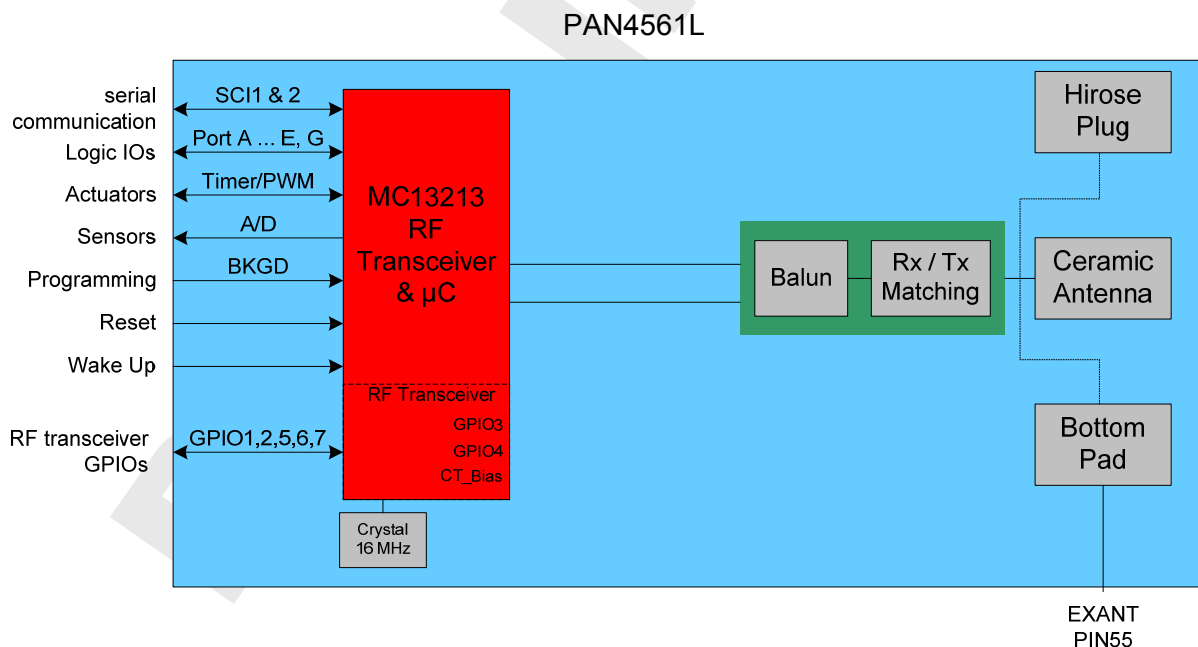

The MC13213 is used in single port configuration with its internal Tx/Rx switch.

For more details refer to chapter 7.1.

CLASSIFICATION	PRODUCT SPECIFICATION	No. DS-4561-2400-102	REV. G
SUBJECT	MODEM FOR 802.15.4 IEEE STANDARD	PAGE 10 of 34	
CUSTOMER'S CODE PAN4561H /M /L	PANASONIC PART NUMBER ENWC9A22xxEF / .25xx. / .21xx.	DATE 06.08.2010	

## 7.1. SOFTWARE DIFFERENCES

### 7.1.1. Test / Demo software

Modules with Test / Demo software are intended for customer writing their own software for the module. The module contains software but only with a small instruction set.

The front end IC CC2591 / CC2590 is enabled and disabled with RF transceiver GPIO4. Set high to enable and low to disable the chip. Please refer to appendix [10].

The LNA has two modes, high and low gain. This mode is controlled with RF transceiver GPIO3. Set it high for high gain and low for low gain mode. Please refer to appendix [10].

The RXTX signal on CC2591 and CC2590 is controlled by CT\_Bias pin. Please refer to appendix [10].

### 7.1.2. E-Senza software

Modules with E-Senza software can be used to set up a measurement system easily with a GUI.

With this software it is not possible to set the modules into energy saving sleep mode.

### 7.1.3. Synapse software

With Synapse software the customer writes his own scripts based on easy to learn, Python based, programming language. This software is very flexible and can be used for multiple applications.

The control of PA/LNA is primary supported from version [SNAPv2.2.15 or newer](#).

The Synapse software on the module provides several initializing parameters called NV-parameters. These are already set. For detailed information refer to SNAP Reference Manual [9].

To comply to FCC regulation the power level has to be reduced to txPwr(14) for PAN4561H. For detailed information on FCC compliance refer to chapter 27. Regulatory Information.

Synapse Wireless Inc. probably releases two to three times a year a new SNAP release. **PAN4561 modules will always be shipped with the [newest SNAP version](#).**

CLASSIFICATION	PRODUCT SPECIFICATION	No. DS-4561-2400-102	REV. G
SUBJECT	MODEM FOR 802.15.4 IEEE STANDARD	PAGE 11 of 34	
CUSTOMER'S CODE PAN4561H /M /L	PANASONIC PART NUMBER ENWC9A22xxEF / .25xx. / .21xx.	DATE 06.08.2010	

## 8. KEY PARTS LIST

Part Name	Material
P.W.Board	Glass cloth epoxide resin with gold plating
Casing	Material: BZn15-20, thickness 0.15mm
IC part name	MC13213 (Freescale <a href="http://www.freescale.com/">www.freescale.com/</a> ) All information are based on [2] chapter 28 CC2591 / CC2590 (Texas Instruments <a href="http://www.ti.com">www.ti.com</a> ) All information are based on [10] chapter 27.

## 9. TEST CONDITIONS

Measurements are made under room temperature and humidity unless otherwise specified.

Temperature  $25 \pm 10^{\circ}\text{C}$       Humidity                      40 to 85%RH  
Supply voltage 3.0V

CLASSIFICATION	PRODUCT SPECIFICATION	No. DS-4561-2400-102	REV. G
SUBJECT	MODEM FOR 802.15.4 IEEE STANDARD	PAGE 12 of 34	
CUSTOMER'S CODE PAN4561H /M /L	PANASONIC PART NUMBER ENWC9A22xxEF / .25xx. / .21xx.	DATE 06.08.2010	

## 10. ABSOLUT MAXIMUM RATINGS

The maximum ratings may not be exceeded under any circumstances (not even momentarily) as permanent damage to the module will result.

No.	Item	Symbol	Absolute Maximum Ratings	Unit
1	Supply voltage	$V_{CC}$	-0.3 to +3.6	Vdc
2	Ripple on $V_{CC}$	$V_{CCrip}$	tbd <sup>(2)</sup> (ripple frequency $\geq 200kHz$ )	mVpp
3	Digital input voltages	$V_{in}$	-0.3 to $V_{CC}+0.3$	Vdc
4	Instantaneous maximum current Single pin limit for all digital I/O pins <sup>(1)</sup>	$I_{BDB}$	$\pm 25$	mAdc
5	Storage temperature range	$T_{stg}$	-40 to +105	°C
6	Operating temperature range	$T_{op}$	-40 to +85	°C
7	RF Input Power	$P_{max}$	10	dBm
8	ESD on any pin except for pin 32 EXANT. Human Body Model (HBM)	$V_{THHBM}$	$\pm 2$	kV
9	Moisture Sensitivity Level	MSL	3 (168 hours)	

Notes:

- (1) Input must be current limited to the value specified. Please refer also to [2].
- (2) The supply voltage must be free of AC ripple voltage (for example from a battery or a low noise regulator output). For noisy supply voltages, please provide a decoupling circuit (for example a ferrite in series connection and a blocking capacitor to ground of at least 47 $\mu$ F directly at the module). The exact ripple tolerance will be published in a later revision.

## 11. OPERATING CONDITIONS

No.	Item	Condition / Remark	Symbol	Value			Unit
				Min	Typ	Max	
1	Supply voltage	The typical value is recommended	$V_{CC}$	2.7	3.0	3.4	Vdc
2	RF Input Frequency		$f_{in}$	2400		2483.5	MHz
3	Return loss of load at pin 55 EXANT	Receive/Transmit Mode to 50 $\Omega$ reference load	a	-9.5			dB
4	Logic Input Voltage Low		$V_{IL}$	0		$0.3 \times V_{CC}$	V
5	Logic Input Voltage High		$V_{IH}$	$0.7 \times V_{CC}$		$V_{CC}$	V
6	SPI clock rate	The typical value is recommended	$f_{SPI}$	-	-	8.0	MHz
7	Operating temperature range		$T_{op}$	-40		+85	°C

CLASSIFICATION	PRODUCT SPECIFICATION	No. DS-4561-2400-102	REV. G
SUBJECT	MODEM FOR 802.15.4 IEEE STANDARD	PAGE 13 of 34	
CUSTOMER'S CODE PAN4561H /M /L	PANASONIC PART NUMBER ENWC9A22xxEF / .25xx. / .21xx.	DATE 06.08.2010	

## 12. DC ELECTRICAL CHARACTERISTICS

Assume  $V_{CC} = 3.0V$ ,  $T_{amb} = 25^{\circ}C$  if nothing else stated

No.	Item	Condition / Remark	Symbol	Module type	Value			Unit
					Min	Typ	Max	
1	Transmit current consumption	Transmit Mode <sup>(8)</sup>	$I_{CCT}$	PAN4561H @ 20dBm <sup>(1)</sup>	'-	200	240	mA
				PAN4561M @ 10dBm	'-	72	80	
				PAN4561L @ 0dBm	'-	43	50	
2	Receive current consumption	Receive Mode <sup>(8)(8)</sup>	$I_{CCR}$	PAN4561H	'-	48	60	mA
				PAN4561M	'-	47	60	
				PAN4561L	'-	45	60	
3	Low power current consumption	Off <sup>(2)(4)</sup> (4)	$I_{leakage}$	PAN4561H	'-	0.55	'-	$\mu A$
				PAN4561M	'-	0.55	'-	
				PAN4561L	'-	0.55	'-	
		Sleep <sup>(2)(5)(9)</sup>	$I_{CCH}$	PAN4561H	'-	2.2	'-	$\mu A$
				PAN4561M	'-	2.2	'-	
				PAN4561L	'-	2.2	'-	
		Standby <sup>(2)(3)(6)(9)</sup>	$I_{CCD}$	PAN4561H	'-	36,3	'-	$\mu A$
				PAN4561M	'-	36,3	'-	
				PAN4561L	'-	36,3	'-	
		Idle <sup>(7)(7)</sup>	$I_{CCI}$	PAN4561H	'-	1.6	'-	mA
				PAN4561M	'-	1.6	'-	
				PAN4561L	'-	1.6	'-	
4	digital I/O pin characteristics			Please refer to [2] 6.3.1 MCU DC Characteristics				
6	Low voltage warning/detection			Please refer to [2] 6.3.1 MCU DC Characteristics				
	Power on reset re-arm voltage							

### Notes:

- (1) SPI Register 12 has a value of 0xDC which sets output power to nominal value.
- (2) To attain specified low power current, all GPIOs and other digital IO must be handled properly. Set all port pins as output low when left open or as input when connected to defined level. Detailed descriptions can be found at [2] at section 7.2 Low Power Considerations.
- (3) CLKO frequency is set to a default value of 32.786 kHz.
- (4) Off mode: Stop1 on  $\mu C$ , Modem off [3]. Wakeup by IRQ or Reset
- (5) Sleep mode: Stop2 + RTC on  $\mu C$ , Modem Hibernate [3]. Wakeup by IRQ, Reset or Real-Time-Interrupt
- (6) Standby mode: Stop3 + RTC on  $\mu C$ , Modem Doze [3]. Wakeup by IRQ, Reset, RTI or Keyboard Interrupt
- (7) Idle mode:  $\mu C$  runs at reduced 2 MHz clock, Modem is in Idle state [3]
- (8)  $\mu C$  runs in full speed mode (16 MHz clock)
- (9) RTC requires external 32 kHz crystal. Without RTC 300nA less current

CLASSIFICATION	PRODUCT SPECIFICATION	No. DS-4561-2400-102	REV. G
SUBJECT	MODEM FOR 802.15.4 IEEE STANDARD	PAGE 14 of 34	
CUSTOMER'S CODE PAN4561H /M /L	PANASONIC PART NUMBER ENWC9A22xxEF / .25xx. / .21xx.	DATE 06.08.2010	

### 13. A/D CONVERTER CHARACTERISTICS

No	Item	Remark
1	ATD characteristics	Please refer to [2] 6.3.3 MCU ATD Characteristics
2	ATD timing/performance characteristics	Please refer to [2] 6.3.3 MCU ATD Characteristics

The A/D high reference voltage VREFH is connected to pin 20 (VREFH). Connect this signal primarily to Vcc.

The A/D low reference voltage VREFL is connected to pin 21 (VREFL). Connect this signal primarily to GND

### 14. AC ELECTRICAL CHARACTERISTICS

$V_{CC} = 3.0V$ ,  $T_{amb} = 25^{\circ}C$ ,  $50\Omega$  load at EXANT, for all channel numbers 11,12,..., 26 according to [1]

No	Receiver	Module type	Limit			Unit
			Min	Typ	Max	
1	Sensitivity for 1% Packet Error Rate (PER), -85dBm required by [1]	PAN4561H	-85	-102	-105	dBm
		PAN4561M	-85	-102	-105	
		PAN4561L	-85	-92	-	
2	Saturation (maximum input level)	All	-	10	-	dBm
3	Adjacent Channel Interference for 1% PER ( $\pm 5MHz$ ; desired signal -82dBm)	All	-	29	-	dB
4	Alternate Channel Interference for 1% PER ( $\pm 10MHz$ ; desired signal -82dBm)	All	-	40	-	dB
5	Frequency Error Tolerance	All	-	-	200	kHz
6	Symbol Rate Error Tolerance	All	-	-	80	ppm
8	Spurious Emissions <1GHz	All	-	-	-57	dBm
9	Spurious Emissions >1GHz	All	-	-	-47	dBm

CLASSIFICATION	PRODUCT SPECIFICATION	No. DS-4561-2400-102	REV. G
SUBJECT	MODEM FOR 802.15.4 IEEE STANDARD	PAGE 15 of 34	
CUSTOMER'S CODE PAN4561H /M /L	PANASONIC PART NUMBER ENWC9A22xxEF / .25xx. / .21xx.	DATE 06.08.2010	

No	Transmitter	Module type	Limit			Unit
			Min	Typ	Max	
1	Maximum Output Power <sup>(1)</sup>	PAN4561H	-	20 <sup>(3)</sup>	22 <sup>(3)</sup>	dBm
		PAN4561M	-	10	-	
		PAN4561L	-	0	-	
2	Nominal Output Power <sup>(2)</sup>	PAN4561H	-	18.5	-	dBm
		PAN4561M	-	9.5	-	
		PAN4561L	-	0	-	
3	Error Vector Magnitude (EVM)		-	25	35	%
4	Power Control Range		-	30	-	dB
5	Over the Air Data Rate		-	250	-	kbps
6	2 <sup>nd</sup> harmonic @ maximum output power		-	-45	-35	dBm
7	3 <sup>rd</sup> harmonic @ maximum output power		-	-45	-35	dBm
8	Spurious Emissions <1GHz		-	< -40	-36	dBm
9	Spurious Emissions >1GHz		-	< -40	-30	dBm

No	Stand By	Limit			Unit
		Min	Typ	Max	
1	Spurious Emissions <1GHz	-	< -60	-57	dBm
2	Spurious Emissions >1GHz	-	< -50	-47	dBm

Notes:

- (1) SPI Register 12 programmed to 0xFF which sets output power to maximum.  
Measured at pin EXANT for the SMD pad version.
- (2) SPI Register 12 programmed to 0xDC which sets output power to nominal value (maximum allowed value to comply with FCC regulation).  
Measured at pin EXANT for the SMD pad version.
- (3) You have to follow your own national regulation, please check before finalizing the max. output power by setting the right register value.



CLASSIFICATION	PRODUCT SPECIFICATION	No. DS-4561-2400-102	REV. G
SUBJECT	MODEM FOR 802.15.4 IEEE STANDARD	PAGE 16 of 34	
CUSTOMER'S CODE PAN4561H /M /L	PANASONIC PART NUMBER ENWC9A22xxEF / .25xx. / .21xx.	DATE 06.08.2010	

## 15. SOLDERING TEMPERATURE - TIME PROFILE (FOR REFLOW SOLDERING)

### 15.1. FOR LEAD SOLDER

#### Recommended temp. profile for reflow soldering

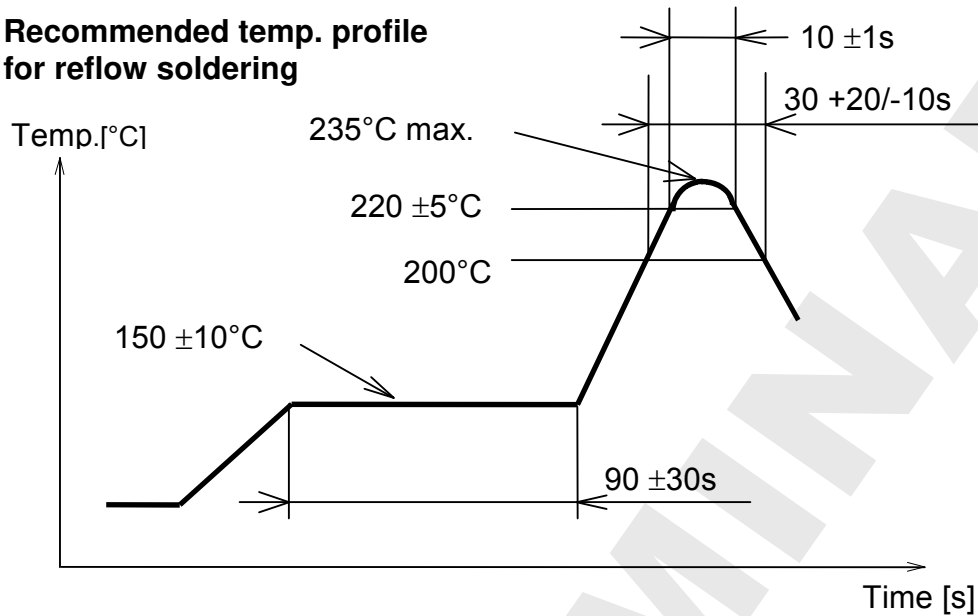

### 15.2. FOR LEAD FREE SOLDER

#### Our used temp. profile for reflow soldering

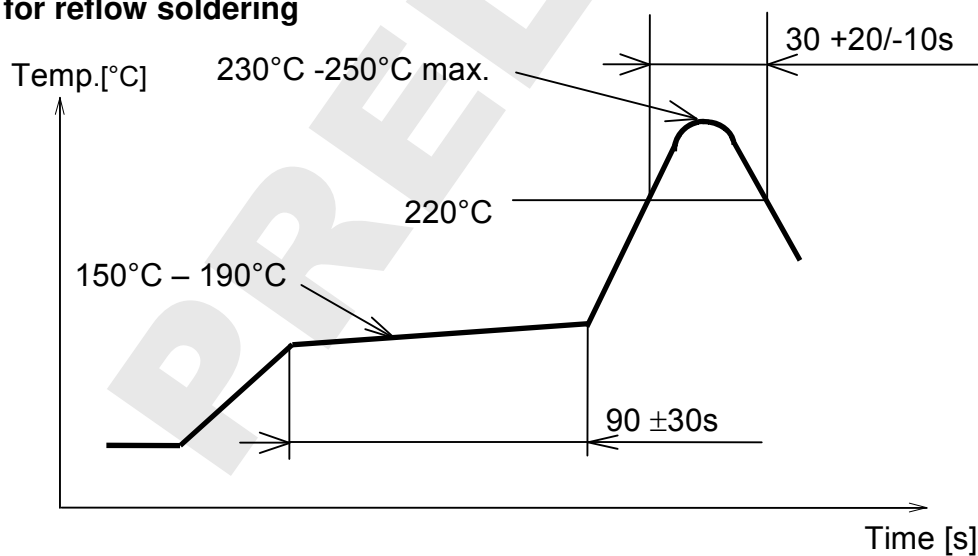

Reflow permissible cycles: 2  
 Opposite side reflow is prohibited due to the module weight.

CLASSIFICATION	PRODUCT SPECIFICATION	No. DS-4561-2400-102	REV. G
SUBJECT	MODEM FOR 802.15.4 IEEE STANDARD	PAGE 17 of 34	
CUSTOMER'S CODE PAN4561H /M /L	PANASONIC PART NUMBER ENWC9A22xxEF / .25xx. / .21xx.	DATE 06.08.2010	

## 16. MODULE DIMENSIONS

No.	Item	Dimension	Tolerance	Remark
1	Width	15.00	$\pm 0.25$	
2	Lenght	35.00	$\pm 0.25$	
3	Height	3.80	$\pm 0.25$	With case

## 17. FOOTPRINT OF THE MODULE

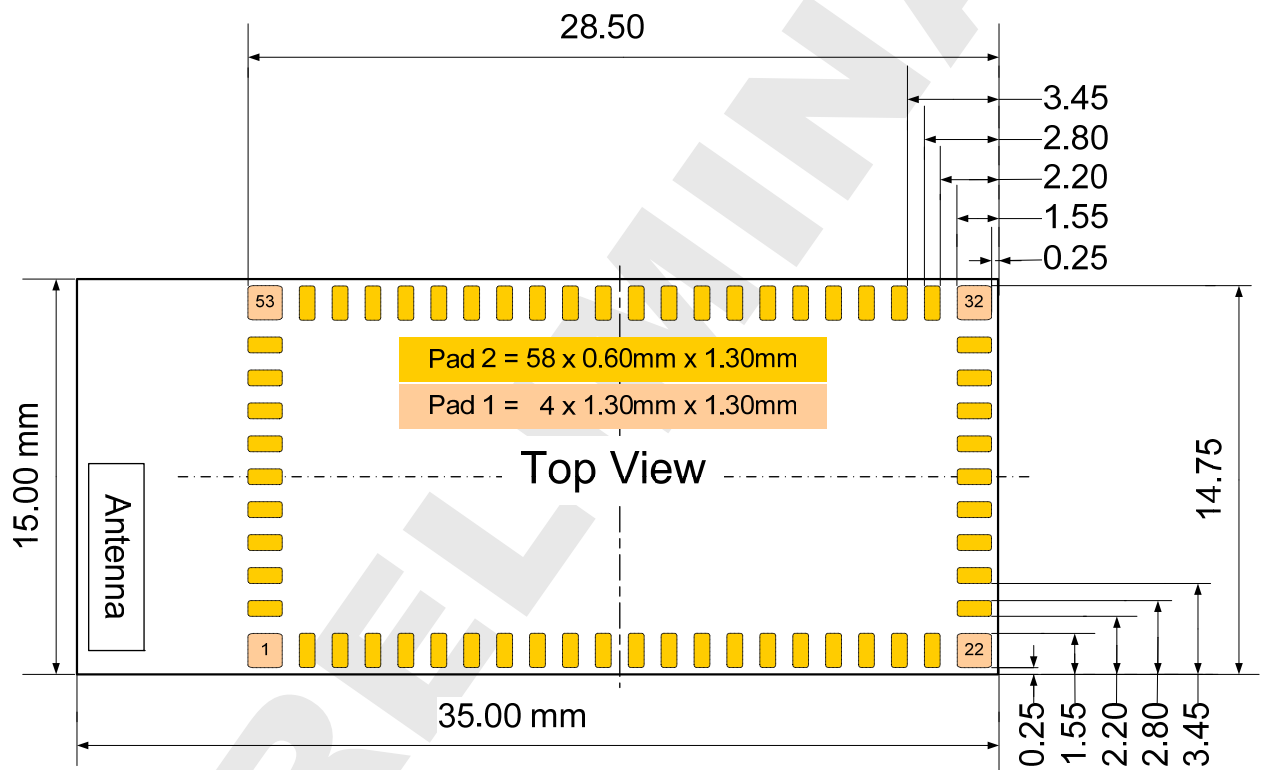

All dimensions are in millimeters.  
The outer dimensions have a tolerance of  $\pm 0.25$ mm.

CLASSIFICATION	PRODUCT SPECIFICATION	No. DS-4561-2400-102	REV. G
SUBJECT	MODEM FOR 802.15.4 IEEE STANDARD	PAGE 18 of 34	
CUSTOMER'S CODE PAN4561H /M /L	PANASONIC PART NUMBER ENWC9A22xxEF / .25xx. / .21xx.	DATE 06.08.2010	

## 18. LASER MARKING

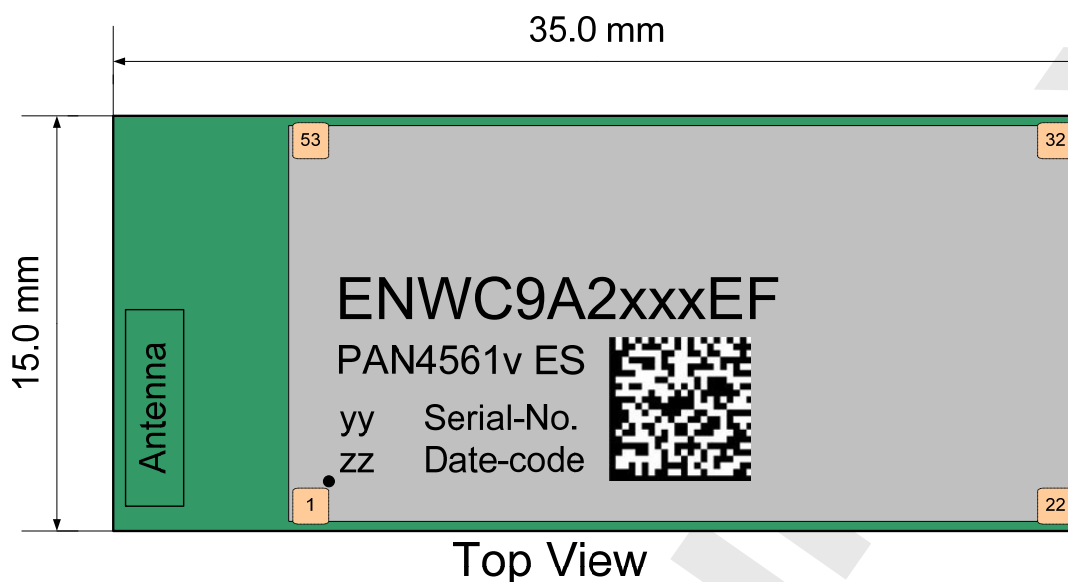

The 2D-Barcode contains the following information separated by a semicolon:

Value	Description
Date-code	Date code in the format Year-Month-Day [YYMMDD]
Serial-No.	Serial number [7 signs, here 0000000]
ENWC9A2xxxEF	Ordering number [8 signs; without ENW and F, please refer also to chapter 24]
v	Module type: H, M or L (for High, Mid and Low power)
yy	The identifier for the hardware release [2 signs, here yy]
zz	The identifier for the software release [2 signs, here zz]

The point on the marking (below left) is the identifier for pin 1 of the module.

## 19. MECHANICAL REQUIREMENTS

No.	Item	Limit	Condition
1	Solderability	More than 75% of the soldering area shall be coated by solder	Reflow soldering with recommendable temperature profile

CLASSIFICATION	PRODUCT SPECIFICATION	No. DS-4561-2400-102	REV. G
SUBJECT	MODEM FOR 802.15.4 IEEE STANDARD	PAGE 19 of 34	
CUSTOMER'S CODE PAN4561H /M /L	PANASONIC PART NUMBER ENWC9A22xxEF / .25xx. / .21xx.	DATE 06.08.2010	

## 20. RECOMMENDED LAND PATTERN

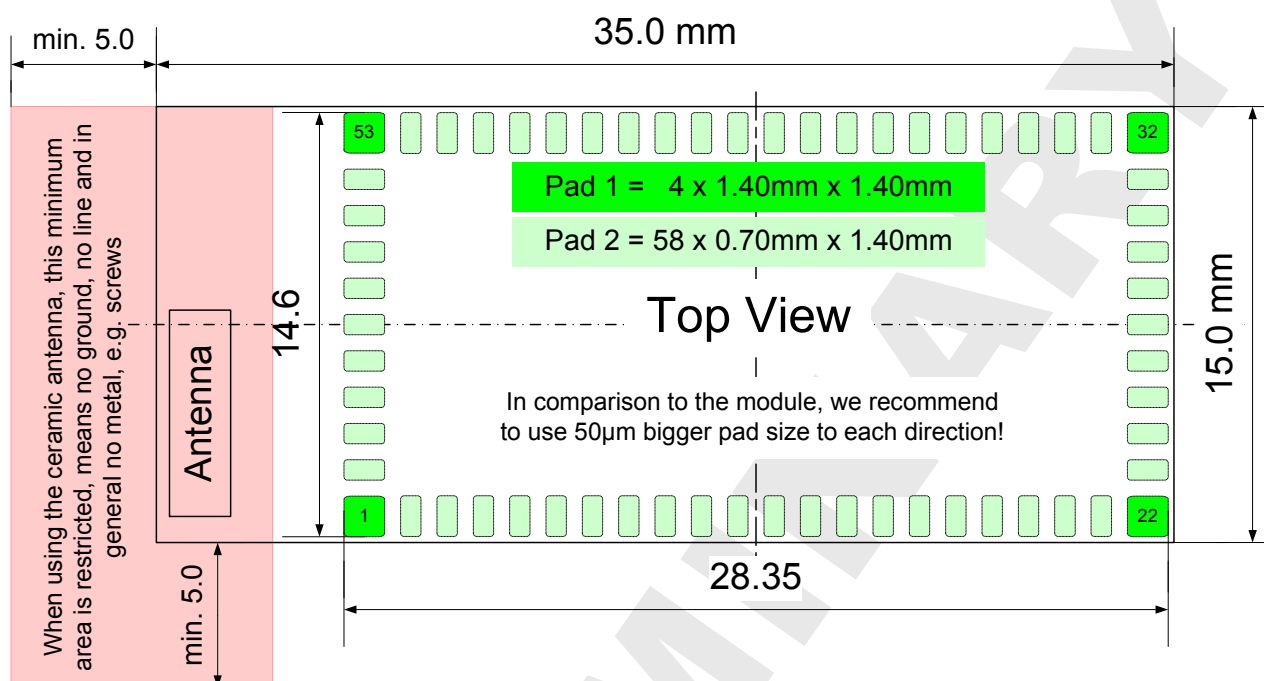

Dimensions in millimeters.

The land pattern dimensions above are meant to serve only as a guide. This information is provided without any legal liability.

For the footprint, it is recommended to incorporate a 50µm bigger size for the pads in each direction compared to the module footprint. Please refer to chapter 17. Foot Print of the Module.

For the solder paste screen, please use the same screen for the module. Solder paste screen cutouts (with slightly different dimensions) might be optimum depending on your soldering process. For example, the chosen solder paste screen thickness might have an effect. The solder screen thickness depends on your production standard. We recommend 120µm to 150µm.

### IMPORTANT:

Although the bottom side of PAN4561 is fully coated, no copper such as through hole vias, planes or tracks on the board component layer should be located below the PAN4561 to avoid creating a short. In cases where a track or through hole via has to be located under the module, please make a note that it has to be kept away from PAN4561 bottom pads. The PAN4561 multilayer pcb contains an inner RF shielding plane, therefore no pcb shielding plane below the module is needed.

When using the antenna pad version, place the antenna on the edge of your carrier board (if allowable).

If you have any questions on these points, please contact your local Panasonic representative.

Before releasing the layout, we recommend to send the schematic and layout for final check to [wireless@eu.panasonic.com](mailto:wireless@eu.panasonic.com).

CLASSIFICATION	PRODUCT SPECIFICATION	No. DS-4561-2400-102	REV. G
SUBJECT	MODEM FOR 802.15.4 IEEE STANDARD	PAGE 20 of 34	
CUSTOMER'S CODE PAN4561H /M /L	PANASONIC PART NUMBER ENWC9A22xxEF / .25xx. / .21xx.	DATE 06.08.2010	

## 21. RELIABILITY TESTS

The measurement should be done after being exposed to room temperature and humidity for 1 hour.

Die Messungen sollten erst nach einer Stunde Lagerung unter normalen Bedingungen erfolgen.

No.	Item	Limit	Condition
1	Vibration test	Electrical parameter should be in specification	a) Freq.:10~50Hz,Amplitude:1.5mm a) 20min. / cycle,1hrs. each of XYZ axis b) Freq.:30~100Hz, 6G b) 20min. / cycle,1hrs. each of XYZ axis
2	Shock test	the same as above	Dropped onto hard wood from height of 50cm for 3 times
3	Heat cycle test	the same as above	-40°C for 30min. and +85°C for 30min.; each temperature 300 cycles
4	Moisture test	the same as above	+60°C, 90% RH, 300h
5	Low temp. test	the same as above	-40°C, 300h
6	High temp. test	the same as above	+85°C, 300h

## 22. CAUTIONS

Failure to do so may result in degrading of the product's functions and damage to the product.

### 22.1. DESIGN NOTES

- (1) Please follow the conditions written in this specification, especially the control signals of this module.
- (2) The supply voltage has to be free of AC ripple voltage (for example from a battery or a low noise regulator output). For noisy supply voltages, provide a decoupling circuit (for example a ferrite in series connection and a blocking capacitor to ground of at least 47uF directly at the module).
- (3) This product should not be mechanically stressed when installed.
- (4) Heat is the major cause of shortening the life of these products. Please keep this product away from heat.  
Avoid assembly and use of the target equipment in conditions where the products' temperature may exceed the maximum tolerance.
- (5) The supply voltage should not be exceedingly high or reversed. It should not carry noise and/or spikes.
- (6) Please keep this product away from other high frequency circuits.

### 22.2. INSTALLATION NOTES

- (1) Reflow soldering is possible twice based on the conditions in chapter 15.  
Please set up the temperature at the soldering portion of this product according to this reflow profile.
- (2) Carefully position the products so that their heat will not burn into printed circuit boards or affect the other components that are susceptible to heat.
- (3) Carefully locate these products so that their temperatures will not increase due to the effects of heat generated by neighboring components.

CLASSIFICATION	PRODUCT SPECIFICATION	No. DS-4561-2400-102	REV. G
SUBJECT	MODEM FOR 802.15.4 IEEE STANDARD	PAGE 21 of 34	
CUSTOMER'S CODE PAN4561H /M /L	PANASONIC PART NUMBER ENWC9A22xxEF / .25xx. / .21xx.	DATE 06.08.2010	

- (4) If a vinyl-covered wire comes into contact with the products, then the cover will melt and generate toxic gas, damaging the insulation. Never allow contact between the cover and these products to occur.
- (5) This product should not be mechanically stressed or vibrated when reflowed.
- (6) If you want to repair your board by hand soldering, please keep the conditions of this chapter.
- (7) Please do not wash this product.
- (8) Please refer to the recommended pattern when designing a board.
- (9) Pressing on parts of the metal cover or fastening objects to the metal will cause damage to the unit.

### 22.3. USAGE CONDITIONS NOTES

- (1) Please take measures to protect the unit against static electricity.  
If pulses or other transient loads (a large load applied in a short time) are applied to the products, check and evaluate their operation before assembly on the final products.
- (2) Please do not use dropped products.
- (3) Please do not touch, damage or place dirt on the pins.
- (4) Please follow the recommended condition ratings about the power supply applied to this product.
- (5) Electrode peeling strength: Do not add pressure of more than 4.9N when soldered on PCB.
- (6) Pressing on parts of the metal cover or fastening objects to the metal cover will cause damage.
- (7) These products are intended for general purpose and standard use in general electronic equipment, such as home appliances, office equipment, information and communication equipment.

CLASSIFICATION	PRODUCT SPECIFICATION	No. DS-4561-2400-102	REV. G
SUBJECT	MODEM FOR 802.15.4 IEEE STANDARD	PAGE 22 of 34	
CUSTOMER'S CODE PAN4561H /M /L	PANASONIC PART NUMBER ENWC9A22xxEF / .25xx. / .21xx.	DATE 06.08.2010	

#### 22.4. STORAGE NOTES

- (1) The module may not be stressed mechanically during storage.
- (2) Do not store these products in the following conditions or the performance characteristics of the product, such as RF performance will be adversely affected:
  - Storage in salty air or in an environment with a high concentration of corrosive gas, such as Cl<sub>2</sub>, H<sub>2</sub>S, NH<sub>3</sub>, SO<sub>2</sub>, or NO<sub>X</sub>
  - Storage in direct sunlight
  - Storage in an environment where the temperature may be outside the range of 5°C to 35°C range, or where the humidity may be outside the 45 to 85% range.
  - Storage of the products for more than one year after the date of delivery at your company if the avoidance all the above conditions (1) to (3) have been met.
- (3) Storage period: Please check the adhesive strength of the embossed tape and soldering after 6 months of storage.
- (4) Please keep this product away from water, poisonous gas and corrosive gas.
- (5) This product should not be stressed or shocked when transported.
- (6) Please follow the specification when stacking packed crates (max. 10).

#### 22.5. SAFETY CAUTIONS

These specifications are intended to preserve the quality assurance of products and individual components.

Before use, check and evaluate the operation when mounted on your products. Abide by these specifications, without deviation when using the products. These products may short-circuit. If electrical shocks, smoke, fire, and/or accidents involving human life are anticipated when a short circuit occurs, then provide the following failsafe functions, as a minimum.

- (1) Ensure the safety of the whole system by installing a protection circuit and a protection device.
- (2) Ensure the safety of the whole system by installing a redundant circuit or another system to prevent a single fault causing an unsafe status.

#### 22.6. OTHER CAUTIONS

- (1) This specification sheet is copyrighted. Please do not disclose it to a third party.
- (2) Please do not use the products for other purposes than those listed.
- (3) Be sure to provide an appropriate fail-safe function on your product to prevent an additional damage that may be caused by the abnormal function or the failure of the product.
- (4) This product has not been manufactured with any ozone chemical controlled under the Montreal Protocol.
- (5) These products are not intended for other uses, other than under the special conditions shown below. Before using these products under such special conditions, check their performance and reliability under the said special conditions carefully to determine whether or not they can be used in such a manner.
  - In liquid, such as water, salt water, oil, alkali, or organic solvent, or in places

CLASSIFICATION	PRODUCT SPECIFICATION	No. DS-4561-2400-102	REV. G
SUBJECT	MODEM FOR 802.15.4 IEEE STANDARD	PAGE 23 of 34	
CUSTOMER'S CODE PAN4561H /M /L	PANASONIC PART NUMBER ENWC9A22xxEF / .25xx. / .21xx.	DATE 06.08.2010	

where liquid may splash.

- In direct sunlight, outdoors, or in a dusty environment
  - In an environment where condensation occurs.
  - In an environment with a high concentration of harmful gas (e.g. salty air, HCl, Cl<sub>2</sub>, SO<sub>2</sub>, H<sub>2</sub>S, NH<sub>3</sub>, and NO<sub>x</sub>)
- (6) If an abnormal voltage is applied due to a problem occurring in other components or circuits, replace these products with new products because they may not be able to provide normal performance even if their electronic characteristics and appearances appear satisfactory.
- (7) When you have any question or uncertainty, both of you and Panasonic sincerely cope with it.



CLASSIFICATION	PRODUCT SPECIFICATION	No. DS-4561-2400-102	REV. G
SUBJECT	MODEM FOR 802.15.4 IEEE STANDARD	PAGE 24 of 34	
CUSTOMER'S CODE PAN4561H / M / L	PANASONIC PART NUMBER ENWC9A22xxEF / .25xx. / .21xx.	DATE 06.08.2010	

## 23. PACKAGING

### 23.1. TAPE DIMENSION

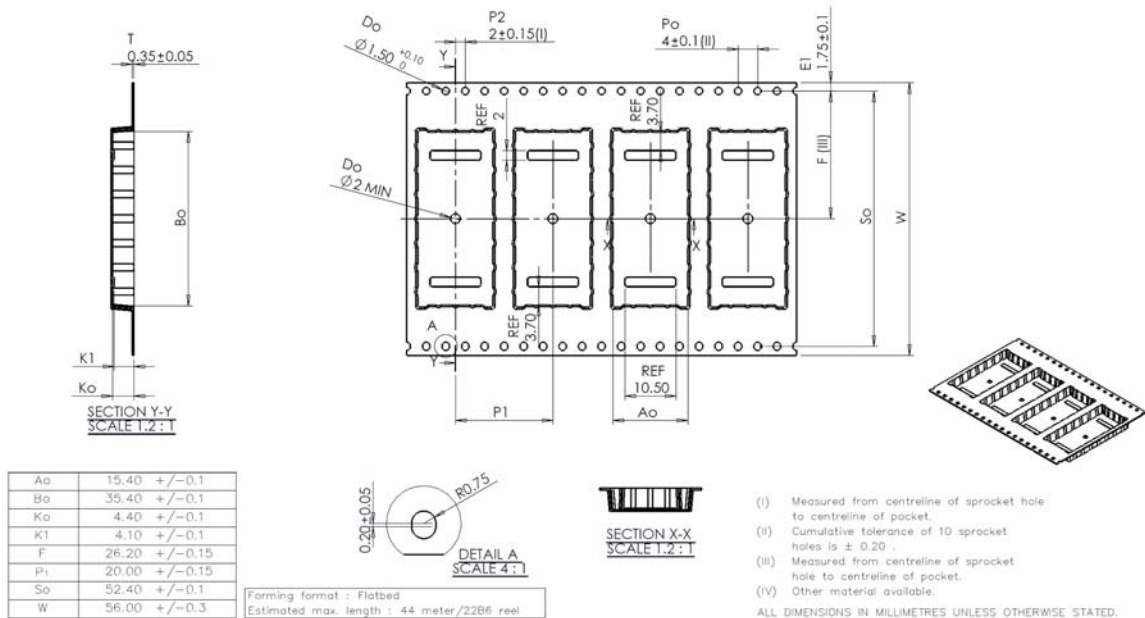

### 23.2. PACKING IN TAPE

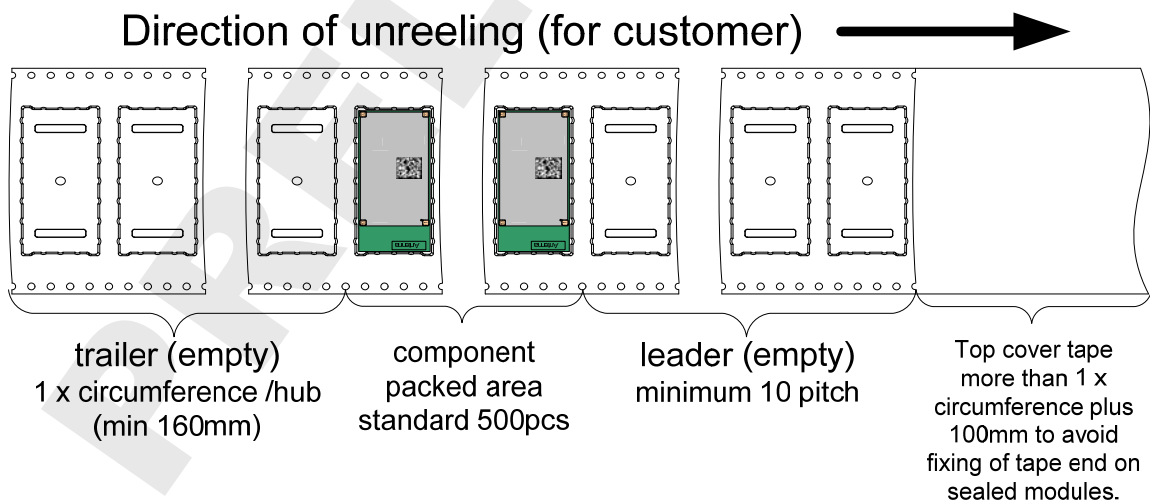

Empty spaces in component packed area shall be less than two per reel and those spaces shall not be consecutive.

Top cover tape shall not be found on reel holes and shall not stick out from reel.

CLASSIFICATION	PRODUCT SPECIFICATION	No. DS-4561-2400-102	REV. G
SUBJECT	MODEM FOR 802.15.4 IEEE STANDARD	PAGE 25 of 34	
CUSTOMER'S CODE PAN4561H /M /L	PANASONIC PART NUMBER ENWC9A22xxEF / .25xx. / .21xx.	DATE 06.08.2010	

### 23.3. COMPONENT DIRECTION

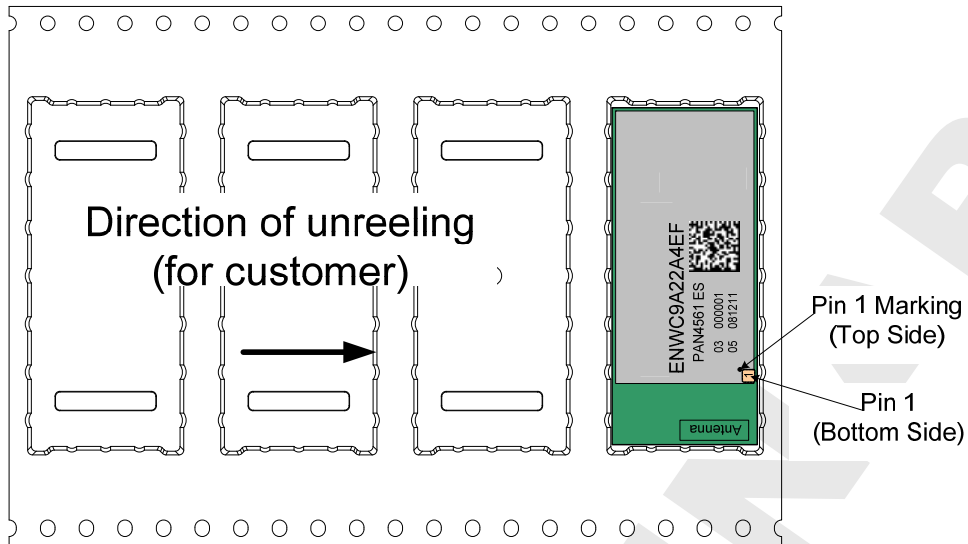

Please refer also to chapter 18. Labeling Drawing

### 23.4. REEL DIMENSION

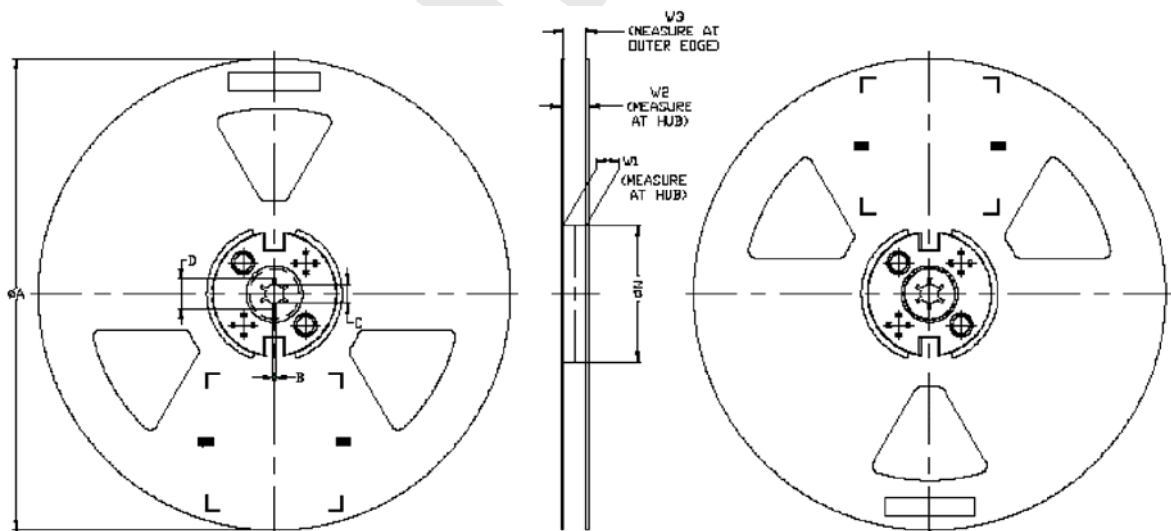

TAPE SIZE	A MAX	B MIN	C	D MIN	N ±1.0	W1	W2 MAX	W3	Assembly Method
24mm	330.0	1.5	13 <sup>+0.5</sup> -0.2	20.2	100.0	25.0 <sup>+2.0</sup> -0.0	30.4	24.4 <sup>+3.0</sup> -0.5	* Latch

All dimensions in millimeters unless otherwise stated

\* Latch (2PC)