



Chipsmall Limited consists of a professional team with an average of over 10 year of expertise in the distribution of electronic components. Based in Hongkong, we have already established firm and mutual-benefit business relationships with customers from,Europe,America and south Asia,supplying obsolete and hard-to-find components to meet their specific needs.

With the principle of "Quality Parts,Customers Priority,Honest Operation,and Considerate Service",our business mainly focus on the distribution of electronic components. Line cards we deal with include Microchip,ALPS,ROHM,Xilinx,Pulse,ON,Everlight and Freescale. Main products comprise IC,Modules,Potentiometer,IC Socket,Relay,Connector.Our parts cover such applications as commercial,industrial, and automotives areas.

We are looking forward to setting up business relationship with you and hope to provide you with the best service and solution. Let us make a better world for our industry!



Contact us

Tel: +86-755-8981 8866 Fax: +86-755-8427 6832

Email & Skype: info@chipsmall.com Web: www.chipsmall.com

Address: A1208, Overseas Decoration Building, #122 Zhenhua RD., Futian, Shenzhen, China



FEATURES

- Single-ended and differential input capability
- User-friendly interface connection
- Optimized EMI suppression filter assembled on board

GENERAL DESCRIPTION

The SSM2335 is a fully integrated, single-chip, mono Class-D audio amplifier. It is designed to maximize performance for mobile phone applications. The application circuit requires a minimum of external components and operates from a single 2.5 V to 5.5 V supply. It is capable of delivering 3 W of continuous output power with less than 1% THD + N driving a 3 Ω load from a single 5.0 V supply.

The SSM2335 comes with a differential mode input port and a high efficiency, full H-bridge at the output that enables direct coupling of the audio power signal to the loudspeaker. The differential mode input stage allows for canceling of common-mode noise.

The part also features a high efficiency, low noise output modulation scheme that requires no external LC output filters when attached to an inductive load. Filterless operation also helps to decrease distortion due to the nonlinearities of output LC filters.

This data sheet describes how to configure and use the SSM2335 evaluation board to test the SSM2335. It is recommended that this data sheet be read in conjunction with the [SSM2335](#) data sheet, which provides more detailed information about the specifications, internal block diagrams, and application guidance for the amplifier IC.

EVALUATION BOARD DESCRIPTION

The SSM2335 evaluation board carries a complete application circuit for driving a loudspeaker. Figure 1 shows the top view of the evaluation board, and Figure 2 shows the bottom view.



Figure 1. SSM2335 Evaluation Board, Top View

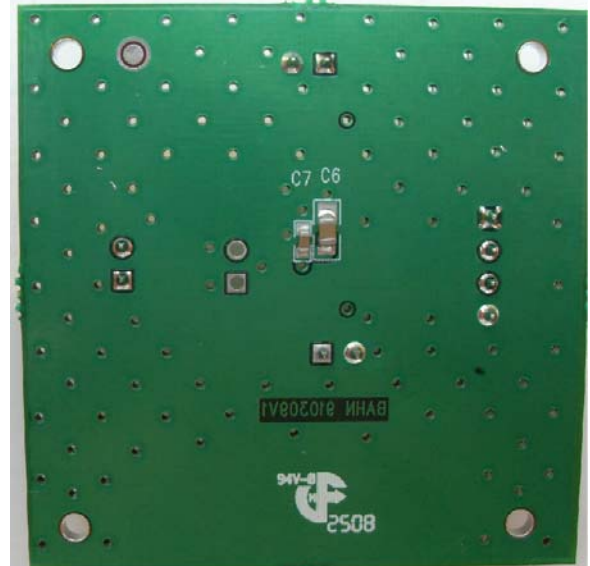

Figure 2. SSM2335 Evaluation Board, Bottom View

Rev. 0

Evaluation boards are only intended for device evaluation and not for production purposes. Evaluation boards are supplied "as is" and without warranties of any kind, express, implied, or statutory including, but not limited to, any implied warranty of merchantability or fitness for a particular purpose. No license is granted by implication or otherwise under any patents or other intellectual property by application or use of evaluation boards. Information furnished by Analog Devices is believed to be accurate and reliable. However, no responsibility is assumed by Analog Devices for its use, nor for any infringements of patents or other rights of third parties that may result from its use. Analog Devices reserves the right to change devices or specifications at any time without notice. Trademarks and registered trademarks are the property of their respective owners. Evaluation boards are not authorized to be used in life support devices or systems.

TABLE OF CONTENTS

Features	1	PCB Layout Guidelines.....	4
General Description	1	Getting Started.....	5
Evaluation Board Description.....	1	What to Test	5
Revision History	2	Evaluation Board Schematic and Artwork.....	6
Evaluation Board Hardware.....	3	Ordering Information	9
Input Configuration	3	Bill of Materials.....	9
Output Configuration.....	3	Ordering Guide	9
Power Supply Configuration.....	3	ESD Caution.....	9
Component Selection.....	3		

REVISION HISTORY

5/09—Revision 0: Initial Version

EVALUATION BOARD HARDWARE

INPUT CONFIGURATION

On the left side of the PCB is a 4-pin header, H2 (see Figure 1). This is used to feed the audio signal into the board.

If the input audio signal is differential (IN+ and IN–), use the two center pins of H2. In this case, either the top or bottom pin should be connected to the source/signal ground.

For a single-ended audio input only two pins of H2 are used. One pin is for the ground and the other pin is for either IN+ or IN–. If IN+ is used, place a jumper between Pin 3 and Pin 4 of H2, shorting IN– to ground. If IN– is used, place the jumper between Pin 1 and Pin 2 of H2, connecting IN+ to the ground.

The 2-pin header, J1, is used to turn the SSM2335 amplifier on or off. Putting a jumper across J1 shuts down the SSM2335 so that only a minimum current (about 20 nA) is drawn from the power supply. Removing the jumper puts the SSM2335 in normal operating mode.

OUTPUT CONFIGURATION

The output connector, H4, is located on the right side of the board (see Figure 1). H4 drives a loudspeaker whose impedance should be no less than 3 Ω.

The SSM2335 does not require any external LC output filters due to a low noise modulation scheme. However, if the speaker length is >10 cm, it is recommended that a ferrite bead (B1 and B2) be placed near each output pin of the SSM2335 to reduce electromagnetic interference (EMI), as shown in the schematic in Figure 4. On the board, there are two inductors, L1 and L2, that are not loaded and not required for normal operation. Some users may want to replace the ferrite beads with these inductors to evaluate applications with specific EMI vs. audio performance constraints.

If L1 and L2 are loaded, the ferrite beads, B1 and B2, must be removed. As an aid, a properly tuned ferrite bead based EMI filter is assembled at the output terminals of the device.

For optimal performance, as specified in the SSM2335 data sheet (in particular, for THD and SNR), remove the entire EMI filter, short across the ferrite bead terminals, and open the capacitor terminals.

POWER SUPPLY CONFIGURATION

The 2-pin header (H1) must be used to power the board, which accepts a 2.5 V ~ 5.5 V dc power supply. Care must be taken to connect the dc power with correct polarity and voltage.

Polarity and Voltage

The wrong power supply polarity or overvoltage may permanently damage the board permanently. The maximum peak current is approximately 0.33 A when driving an 8 Ω load and when the input voltage is 5 V.

COMPONENT SELECTION

Selecting the proper components is the key to achieving the performance required at the budgeted cost.

Input Coupling Capacitor Selection—C1 and C2

The input coupling capacitors, C1 and C2, should be large enough to couple the low frequency signal components in the incoming signal and small enough to filter out unnecessary low frequency signals. For music signals, the cutoff frequency chosen is often between 20 Hz and 30 Hz. The value of the input capacitor is calculated by

$$C = 1/(2\pi Rf_c)$$

where:

$R = 20 \text{ k}\Omega + R_{EXT}$ (the external resistor used to fine-tune the desired gain; on the schematics (see Figure 4), this is the 0 Ω resistor at the input pins).

f_c is the cutoff frequency.

Output Ferrite Beads—B1 and B2

The output beads, B1 and B2, are necessary components for filtering out the EMI caused at the switching output nodes when the length of the speaker wire is greater than 10 cm. The penalty for using ferrite beads for EMI filtering is slightly worse noise and distortion performance at the system level due to the nonlinearity of the beads.

Ensure that these beads have enough current conducting capability while providing sufficient EMI attenuation. The current rating needed for an 8 Ω load is approximately 420 mA, and impedance at 100 MHz must be $\geq 120 \Omega$. In addition, the lower the dc resistance (DCR) of these beads, the better for minimizing their power consumption.

Table 1 describes the recommended beads.

EVAL-SSM2335

Table 1. Recommended Output Beads (B1 and B2)

Part No.	Manufacturer	Z (Ω)	I _{MAX} (mA)	DCR (Ω)	Size (mm)
BLM18PG121SN1D	Murata	120	2000	0.05	1.6 × 0.8 × 0.8
MPZ1608S101A	TDK	100	3000	0.03	1.6 × 0.8 × 0.8
MPZ1608S221A	TDK	220	2000	0.05	1.6 × 0.8 × 0.8
BLM18EG221SN1D	Murata	220	2000	0.05	1.6 × 0.8 × 0.8

Table 2. Recommended Output Inductors (L1 and L2)

Part No.	Manufacturer	L (μ H)	I _{MAX} (mA)	DCR (Ω)	Size (mm)
LQM31PNR47M00	Murata	0.47	1400	0.07	3.2 × 1.6 × 0.85
LQM31PN1R0M00	Murata	1.0	1200	0.12	3.2 × 1.6 × 0.85
LQM21PNR47MC0	Murata	0.47	1100	0.12	2.0 × 1.25 × 0.5
LQM21PN1R0MC0	Murata	1.0	800	0.19	2.0 × 1.25 × 0.5
LQH32CN2R2M53	Murata	2.2	790	0.1	3.2 × 2.5 × 1.55
LBC2518T2R2M	Taiyo Yuden	2.2	630	0.13	2.5 × 1.8 × 2
1033AS-4R7M	Toko	4.7	680	0.31	3.8 × 3.8 × 1

Output Shunting Capacitors

There are two output shunting capacitors, C3 and C4, that work with the B1 and B2 ferrite beads or with the L1 and L2 inductors, if they are used. Use small size (0603 or 0402), multilayer ceramic capacitors that are made of X7R or COG (NPO) materials. Note that the capacitors can be used in pairs: a capacitor with small capacitance (up to 100 pF) plus a capacitor with a larger capacitance (less than 1 nF). This configuration provides thorough EMI reduction for the entire frequency spectrum. For BOM cost reduction and capable performance, a single capacitor of approximately 470 pF can be used.

Output Inductors—L3 and L4

If you prefer using inductors for the purpose of EMI filtering at the output nodes, choose inductance that is <2.2 μ H for these inductors. The higher the inductance, the lower the EMI is at the output. However, the cost and power consumption by the inductors are higher. Using 0.47 μ H to 2.2 μ H inductors is recommended, and the current rating needs >600 mA (saturation current) for an 8 Ω load. Table 2 shows the recommended inductors. Note that these inductors are not populated on the evaluation board.

PCB LAYOUT GUIDELINES

To keep the EMI under the allowable limit and to ensure that the amplifier chip operates under the temperature limit, PCB layout is critical in application design. Figure 3 shows the preferred layout for the SSM2335 evaluation board.

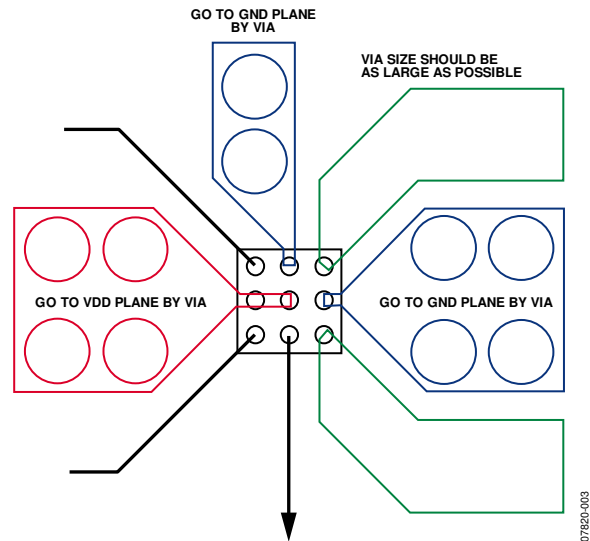

Figure 3. Preferred PCB Layout for the SSM2335 Evaluation Board

Layer Stacks and Grounding

The stack-up for the evaluation board is a 4-layer structure.

- Top layer—component layer with power and output copper land and ground copper pouring.
- Second layer—dedicated ground plane.
- Third layer—dedicated power plane.
- Bottom layer—bottom layer with ground copper pouring.

Component Placement and Clearance

Place all related components except decoupling capacitors on the same side as the SSM2335 and as close as possible to the chip to avoid vias (see Figure 5).

Place decoupling capacitors on the bottom side and close to the GND pin (see Figure 7).

Top Layer Copper Land and Ground Pouring

The output peak current of this amplifier is more than 1 A; therefore, PCB traces should be wide (>2 mm) to handle the high current. For the best performance, use symmetrical copper lands as large as space allows (instead of traces) for the output pins (see Figure 3).

Pour ground copper on the top side and use many vias to connect the top layer ground copper to the dedicated ground plane. The copper pouring on the top layer serves as both the EMI shielding ground plane and the heat sink for the SSM2335.

The SSM2335 works well only if these techniques are implemented in the PCB design to keep EMI and the amplifier temperature low.

GETTING STARTED

To ensure proper operation, carefully follow Step 1 through Step 4.

1. If a jumper is on J1, remove the jumper to activate the amplifier.
2. Connect the load to the audio output connector, H4.
3. Connect the audio input to the board, either in differential mode or single-ended mode, depending on the application.
4. Connect the power supply with the proper polarity and voltage.

WHAT TO TEST

When implementing the SSM2335 evaluation board, test the board for the following?

- Electromagnetic interference (EMI)—connect wires for the speakers, making sure they are the same length as the wires required for the actual application environment; then complete the EMI test.
- Signal-to-noise ratio (SNR).
- Output noise—make sure to use an A-weighted filter to filter the output before reading the measurement meter.
- Maximum output power.
- Distortion.
- Efficiency.

EVAL-SSM2335

EVALUATION BOARD SCHEMATIC AND ARTWORK

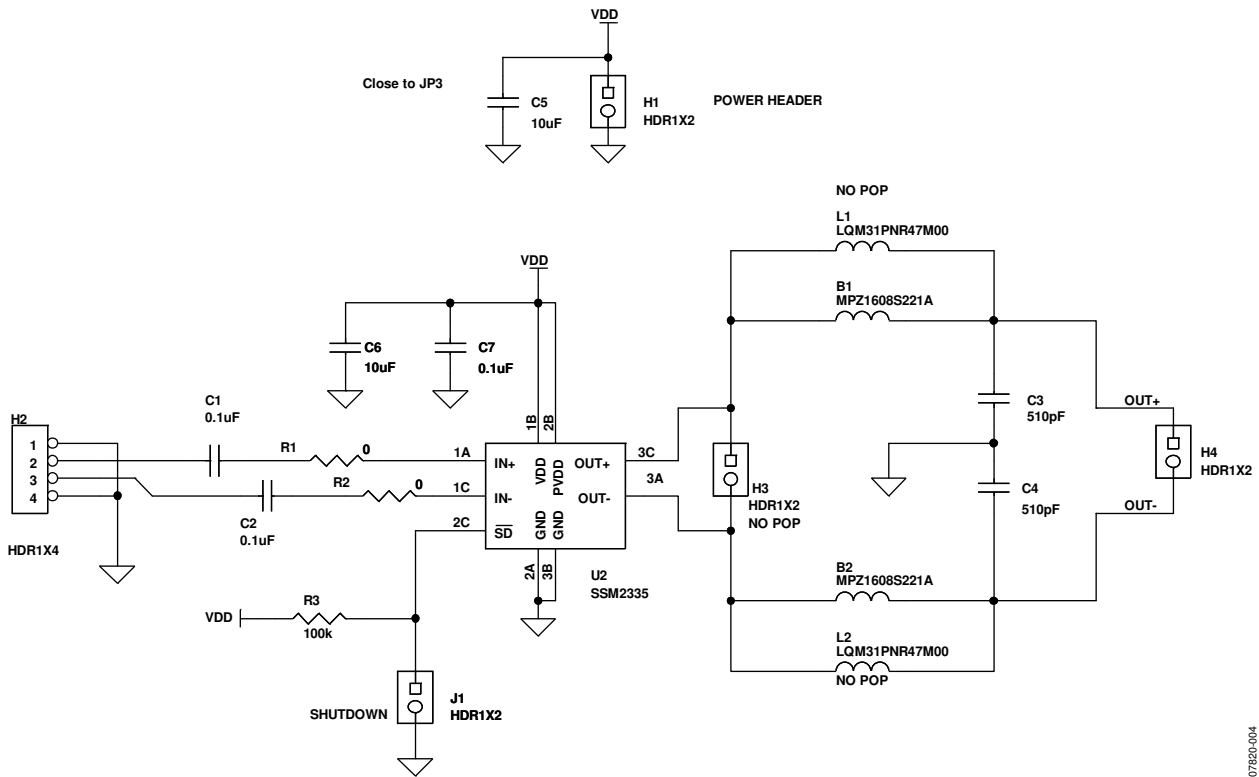

Figure 4. Schematic of the SSM2335 Evaluation Board

07520-004

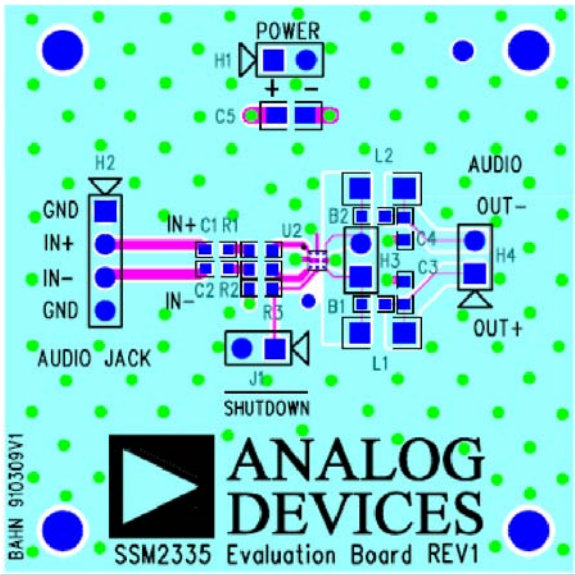

Figure 5. Top Layer with Top Silkscreen

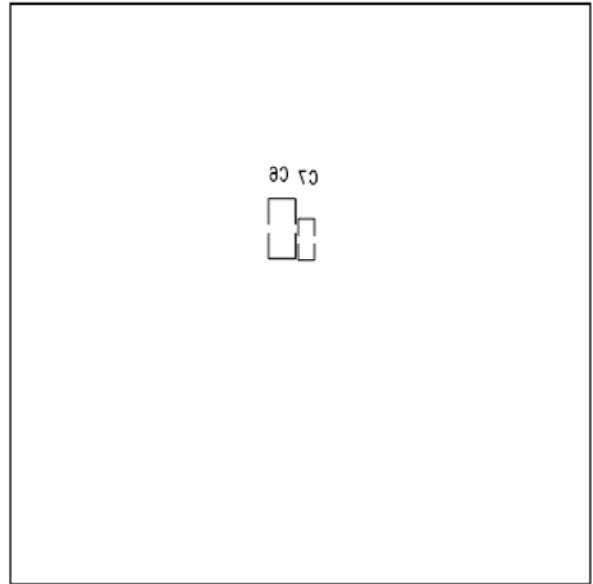

Figure 7. Bottom Silkscreen

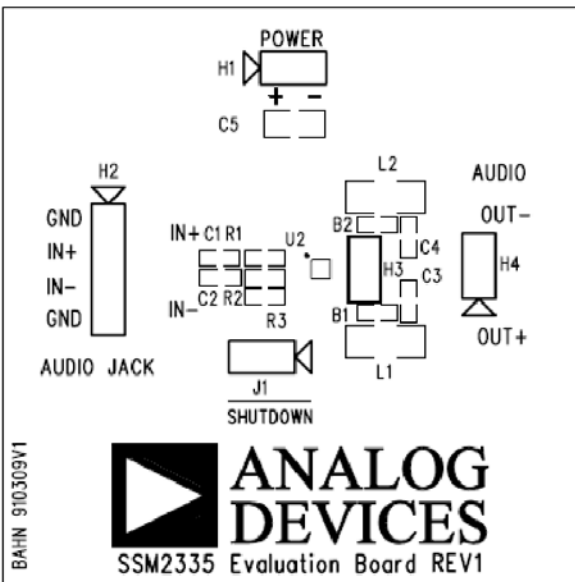

Figure 6. Top Silkscreen

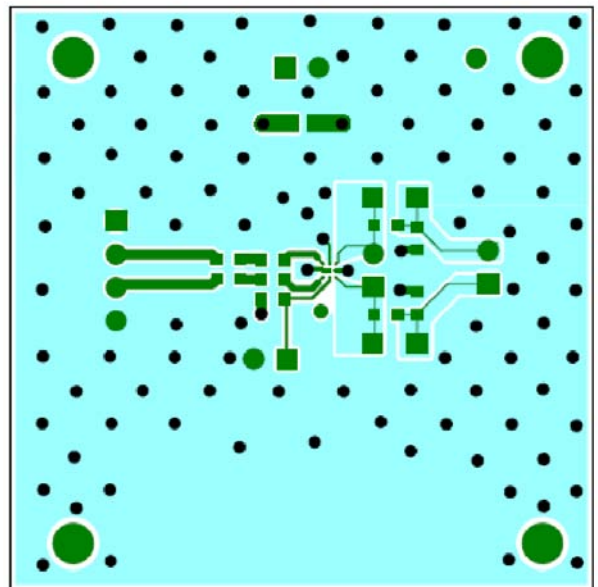
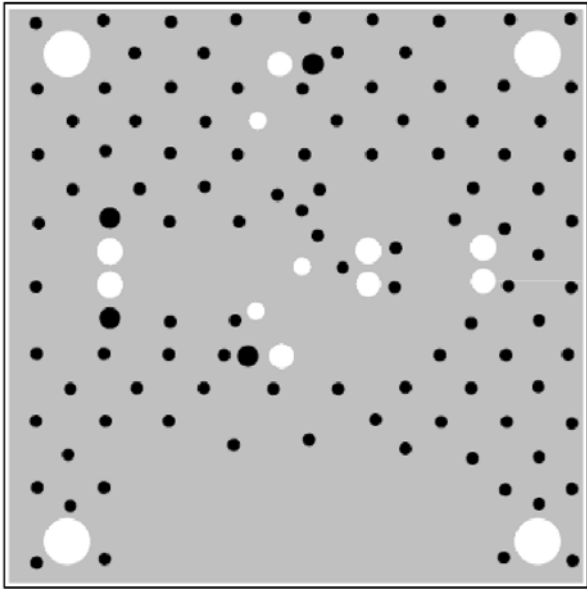
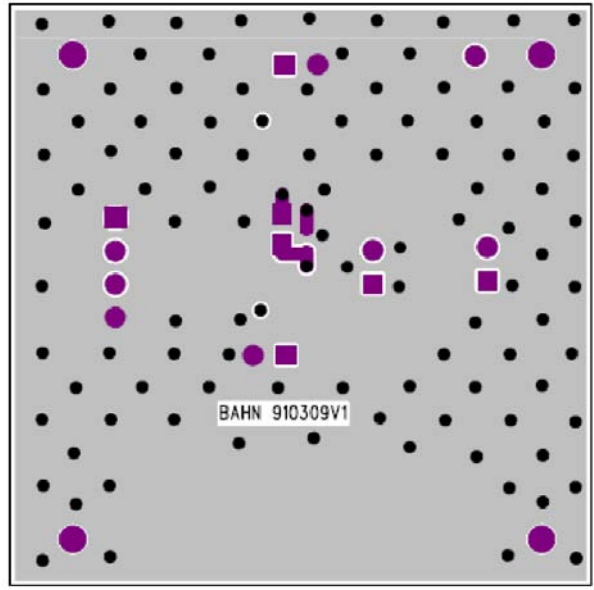

Figure 8. Top Layer



07820-009

Figure 9. Layer 2 (Ground Plane)



07820-011

Figure 11. Bottom Layer

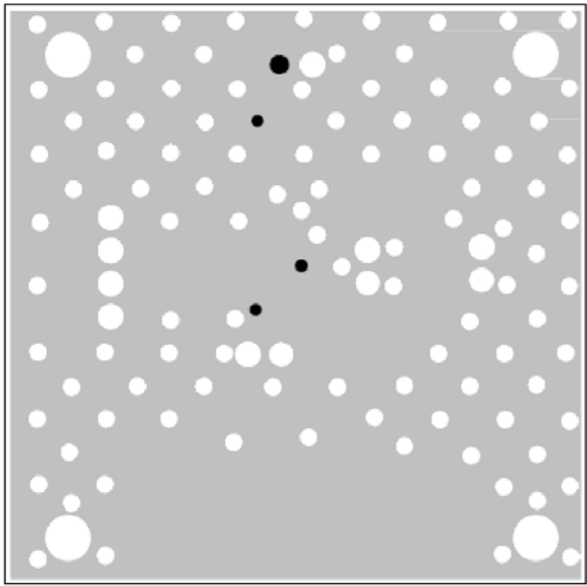

07820-010

Figure 10. Layer 3 (Power Plane)

ORDERING INFORMATION

BILL OF MATERIALS

Table 3.

Qty	Reference Designator	Description	Supplier/Part No.
2	B1, B2	Ferrite bead, 220 Ω , 2 A	TDK, MPZ1608S221A
3	C1, C2, C7	Ceramic capacitor, 0.1 μ F, 0603	Panasonic, ECJ-1VB1C104K
2	C3, C4	Ceramic capacitor, 510 pF	Murata, GRM1885C2A511JA01D
2	C5, C6	Ceramic capacitor, 10 μ F, 10 V	Murata, GRM21BR61A106KE19L
3	J1, H1, H4	HDR1X2, two-position header	Tyco, 4-103747-0-02
1	H2	HDR1X4, four-position header, not populated	Tyco, 4-103747-0-04
1	H3	HDR1X2, two-position header, not populated	Tyco, 4-103747-0-02
2	L1, L2	470 nH inductor	Murata, LQM31PNR47M00
2	R1, R2	Resistor, 0 Ω	Yaego, 9C06031A0R00JLHFT
1	R3	Resistor, 100 k Ω	Panasonic, ERJ-3EKF1003V
1	U2	SSM2335	Analog Devices, SSM2335

ORDERING GUIDE

Model	Description
EVAL-SSM2335Z ¹	Evaluation Board

¹ Z = RoHS Compliant Part.

ESD CAUTION



ESD (electrostatic discharge) sensitive device. Charged devices and circuit boards can discharge without detection. Although this product features patented or proprietary protection circuitry, damage may occur on devices subjected to high energy ESD. Therefore, proper ESD precautions should be taken to avoid performance degradation or loss of functionality.

NOTES

NOTES

NOTES