



Chipsmall Limited consists of a professional team with an average of over 10 year of expertise in the distribution of electronic components. Based in Hongkong, we have already established firm and mutual-benefit business relationships with customers from,Europe,America and south Asia,supplying obsolete and hard-to-find components to meet their specific needs.

With the principle of "Quality Parts,Customers Priority,Honest Operation,and Considerate Service",our business mainly focus on the distribution of electronic components. Line cards we deal with include Microchip,ALPS,ROHM,Xilinx,Pulse,ON,Everlight and Freescale. Main products comprise IC,Modules,Potentiometer,IC Socket,Relay,Connector.Our parts cover such applications as commercial,industrial, and automotives areas.

We are looking forward to setting up business relationship with you and hope to provide you with the best service and solution. Let us make a better world for our industry!



Contact us

Tel: +86-755-8981 8866 Fax: +86-755-8427 6832

Email & Skype: info@chipsmall.com Web: www.chipsmall.com

Address: A1208, Overseas Decoration Building, #122 Zhenhua RD., Futian, Shenzhen, China





EVAL5987 EVAL5987A

3 A step-down switching regulator demonstration board based on the L5987, L5987A

Data brief

Features

- 3 A DC output current
- 2.9 V to 18 V input voltage
- Output voltage adjustable from 0.6 V to 16 V
- 250 kHz switching frequency, programmable up to 1 MHz
- Internal soft-start and inhibit
- Low dropout operation: 100% duty cycle
- Zero-load current operation
- Overcurrent and thermal protection
- VFQFPN8 3 mm x 3 mm package or HSOP8 for the L5987A

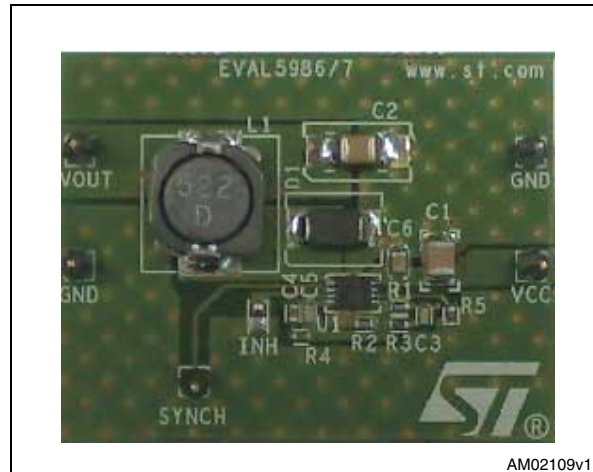

Description

The EVAL5987/A demonstration board provides the design engineer with a fully functional step-down switching regulator with an output current of up to 3 A. The board integrates STMicroelectronics' L5987/A step-down switching regulator, together with all the external components required for a typical application.

The rated voltage of the input capacitor and the Schottky diode rectifier repetitive peak reverse voltage are both 25 V, making the board capable of covering the entire 2.9 V - 18 V input voltage range of the L5987/A device.

The board features an external resistor divider (R1 and R2) designed for an output voltage of 1.8 V.

The output voltage can be set to a level from 0.6 V up to the input voltage.

The compensation network on the demonstration board allows the use of MLCC as output filter to keep the loop stable. The inductor saturation current and forward current of the Schottky diode are within the current limit values.

The switching frequency on the demonstration board is set to 500 kHz by means of the R5 resistor connected to pin Fsw.

1 EVAL5987/A application circuit and component list

Figure 1. Application circuit

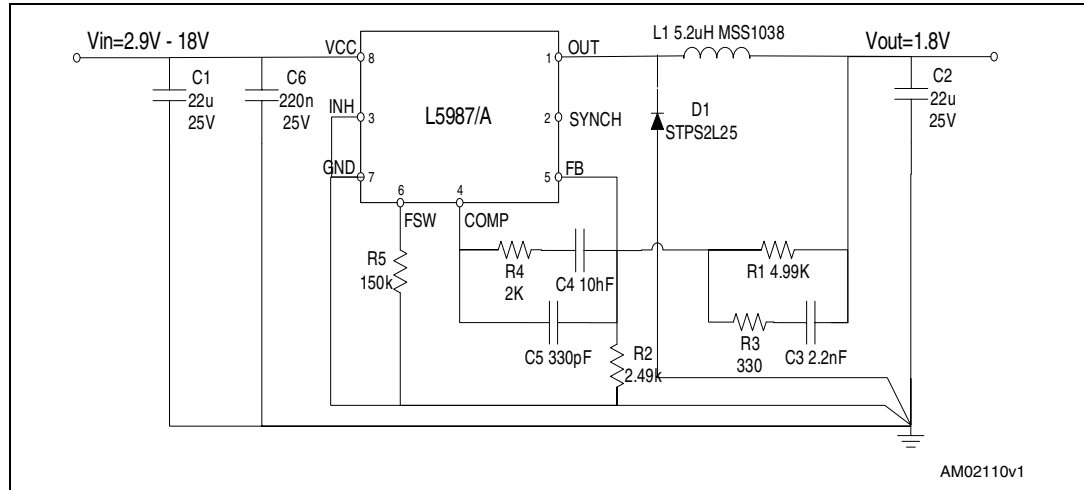

Figure 2. Package

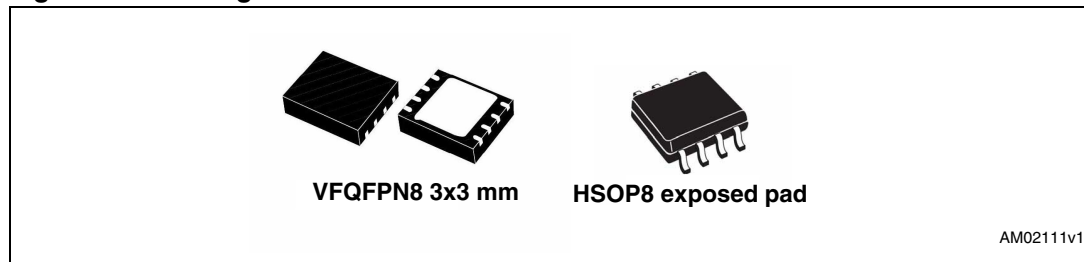

Table 1. Component list

Reference	Part number	Description	Manufacturer
C1	GRM32ER61E226KE15	22 µF, 25 V	Murata
C2	GRM32ER61E226KE15	22 µF, 25 V	Murata
C3		2.2 nF, 50 V	
C4		10 nF, 50 V	
C5		330 pF, 50 V	
C6		220 nF, 25 V	
R1		4.99 kΩ, 1%, 0.1 W 0603	
R2		2.49 kΩ, 1%, 0.1 W 0603	
R3		330 Ω, 1%, 0.1 W 0603	
R4		2 kΩ, 1%, 0.1 W 0603	
R5		100 kΩ, 1%, 0.1 W 0603	
L1	MSS1038-522NL	5.2 µH, 30%, 5.28 A	Coilcraft
D1	STPS2L25V	2 A, 25 V	STMicroelectronics

2 PCB layout

Figure 3. PCB layout (component side)

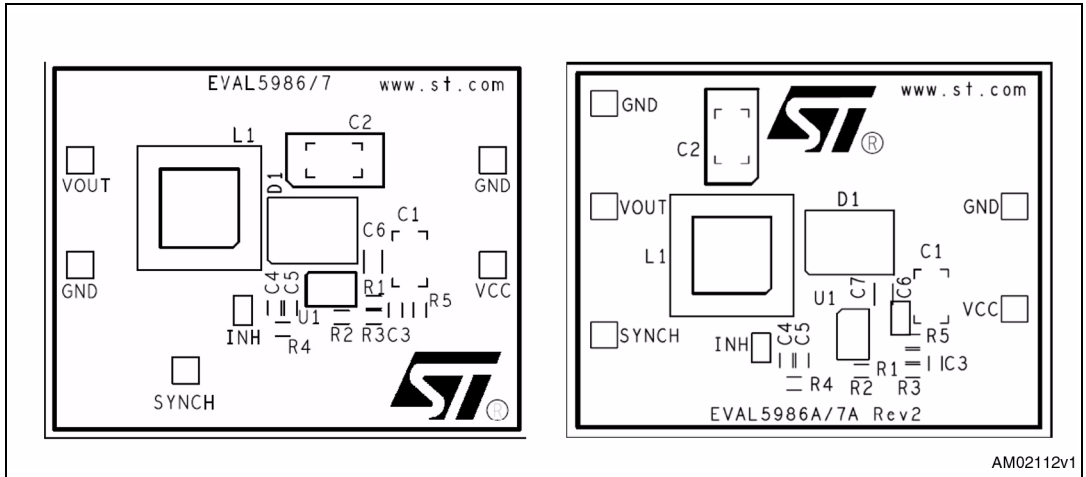

Figure 4. PCB layout (bottom side)

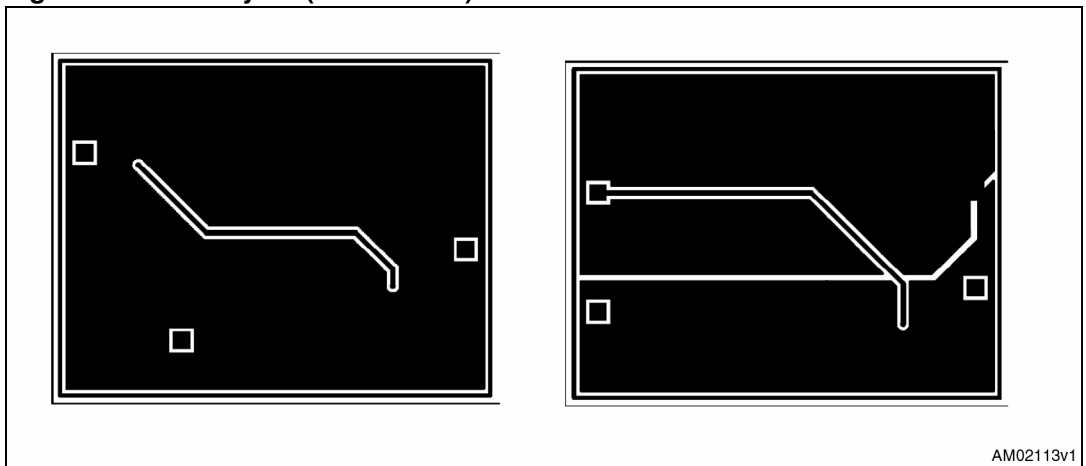
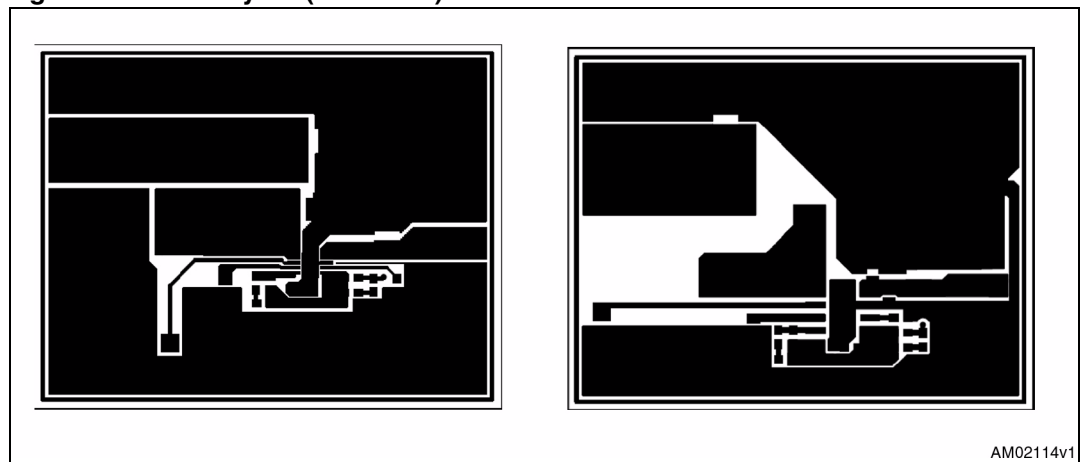

Figure 5. PCB layout (front side)



3 Package mechanical data

In order to meet environmental requirements, ST offers these devices in different grades of ECOPACK[®] packages, depending on their level of environmental compliance. ECOPACK[®] specifications, grade definitions and product status are available at: www.st.com. ECOPACK[®] is an ST trademark.

4 Revision history

Table 2. Document revision history

Date	Revision	Changes
04-Nov-2009	1	Initial release

Please Read Carefully:

Information in this document is provided solely in connection with ST products. STMicroelectronics NV and its subsidiaries ("ST") reserve the right to make changes, corrections, modifications or improvements, to this document, and the products and services described herein at any time, without notice.

All ST products are sold pursuant to ST's terms and conditions of sale.

Purchasers are solely responsible for the choice, selection and use of the ST products and services described herein, and ST assumes no liability whatsoever relating to the choice, selection or use of the ST products and services described herein.

No license, express or implied, by estoppel or otherwise, to any intellectual property rights is granted under this document. If any part of this document refers to any third party products or services it shall not be deemed a license grant by ST for the use of such third party products or services, or any intellectual property contained therein or considered as a warranty covering the use in any manner whatsoever of such third party products or services or any intellectual property contained therein.

UNLESS OTHERWISE SET FORTH IN ST'S TERMS AND CONDITIONS OF SALE ST DISCLAIMS ANY EXPRESS OR IMPLIED WARRANTY WITH RESPECT TO THE USE AND/OR SALE OF ST PRODUCTS INCLUDING WITHOUT LIMITATION IMPLIED WARRANTIES OF MERCHANTABILITY, FITNESS FOR A PARTICULAR PURPOSE (AND THEIR EQUIVALENTS UNDER THE LAWS OF ANY JURISDICTION), OR INFRINGEMENT OF ANY PATENT, COPYRIGHT OR OTHER INTELLECTUAL PROPERTY RIGHT.

UNLESS EXPRESSLY APPROVED IN WRITING BY AN AUTHORIZED ST REPRESENTATIVE, ST PRODUCTS ARE NOT RECOMMENDED, AUTHORIZED OR WARRANTED FOR USE IN MILITARY, AIR CRAFT, SPACE, LIFE SAVING, OR LIFE SUSTAINING APPLICATIONS, NOR IN PRODUCTS OR SYSTEMS WHERE FAILURE OR MALFUNCTION MAY RESULT IN PERSONAL INJURY, DEATH, OR SEVERE PROPERTY OR ENVIRONMENTAL DAMAGE. ST PRODUCTS WHICH ARE NOT SPECIFIED AS "AUTOMOTIVE GRADE" MAY ONLY BE USED IN AUTOMOTIVE APPLICATIONS AT USER'S OWN RISK.

Resale of ST products with provisions different from the statements and/or technical features set forth in this document shall immediately void any warranty granted by ST for the ST product or service described herein and shall not create or extend in any manner whatsoever, any liability of ST.

ST and the ST logo are trademarks or registered trademarks of ST in various countries.

Information in this document supersedes and replaces all information previously supplied.

The ST logo is a registered trademark of STMicroelectronics. All other names are the property of their respective owners.

© 2009 STMicroelectronics - All rights reserved

STMicroelectronics group of companies

Australia - Belgium - Brazil - Canada - China - Czech Republic - Finland - France - Germany - Hong Kong - India - Israel - Italy - Japan - Malaysia - Malta - Morocco - Philippines - Singapore - Spain - Sweden - Switzerland - United Kingdom - United States of America

www.st.com