



Chipsmall Limited consists of a professional team with an average of over 10 year of expertise in the distribution of electronic components. Based in Hongkong, we have already established firm and mutual-benefit business relationships with customers from,Europe,America and south Asia,supplying obsolete and hard-to-find components to meet their specific needs.

With the principle of “Quality Parts,Customers Priority,Honest Operation,and Considerate Service”,our business mainly focus on the distribution of electronic components. Line cards we deal with include Microchip,ALPS,ROHM,Xilinx,Pulse,ON,Everlight and Freescale. Main products comprise IC,Modules,Potentiometer,IC Socket,Relay,Connector.Our parts cover such applications as commercial,industrial, and automotives areas.

We are looking forward to setting up business relationship with you and hope to provide you with the best service and solution. Let us make a better world for our industry!



Contact us

Tel: +86-755-8981 8866 Fax: +86-755-8427 6832

Email & Skype: info@chipsmall.com Web: www.chipsmall.com

Address: A1208, Overseas Decoration Building, #122 Zhenhua RD., Futian, Shenzhen, China



Fully integrated microstepping motor driver using the L6470

Data brief

Features

- Voltage range from 8 V to 45 V
- Phase current up to 3 A_{r.m.s.}
- SPI with daisy-chain feature
- Socket for external resonator or crystal
- SW input
- Thermal resistance junction-to-ambient of 40 °C/W (typical)
- Suitable to be used in combination with STEVAL-PCC009V2

Description

The EVAL6470 demonstration board is a fully integrated microstepping motor driver. In combination with the STEVAL-PCC009V2 communication board and the dSPIN Evaluation Software, the board allows the engineer to investigate all the features of the L6470 device.

In particular, the board can be used to check the voltage mode driving and to regulate the L6470 parameters in order to fit the application requirements.

Two or more EVAL6470 can be driven by a single communication board making the demonstration board suitable for the evaluation of L6470 in multi-motor applications.



1 Board description

Figure 1. EVAL6470 demonstration board jumper and connector locations

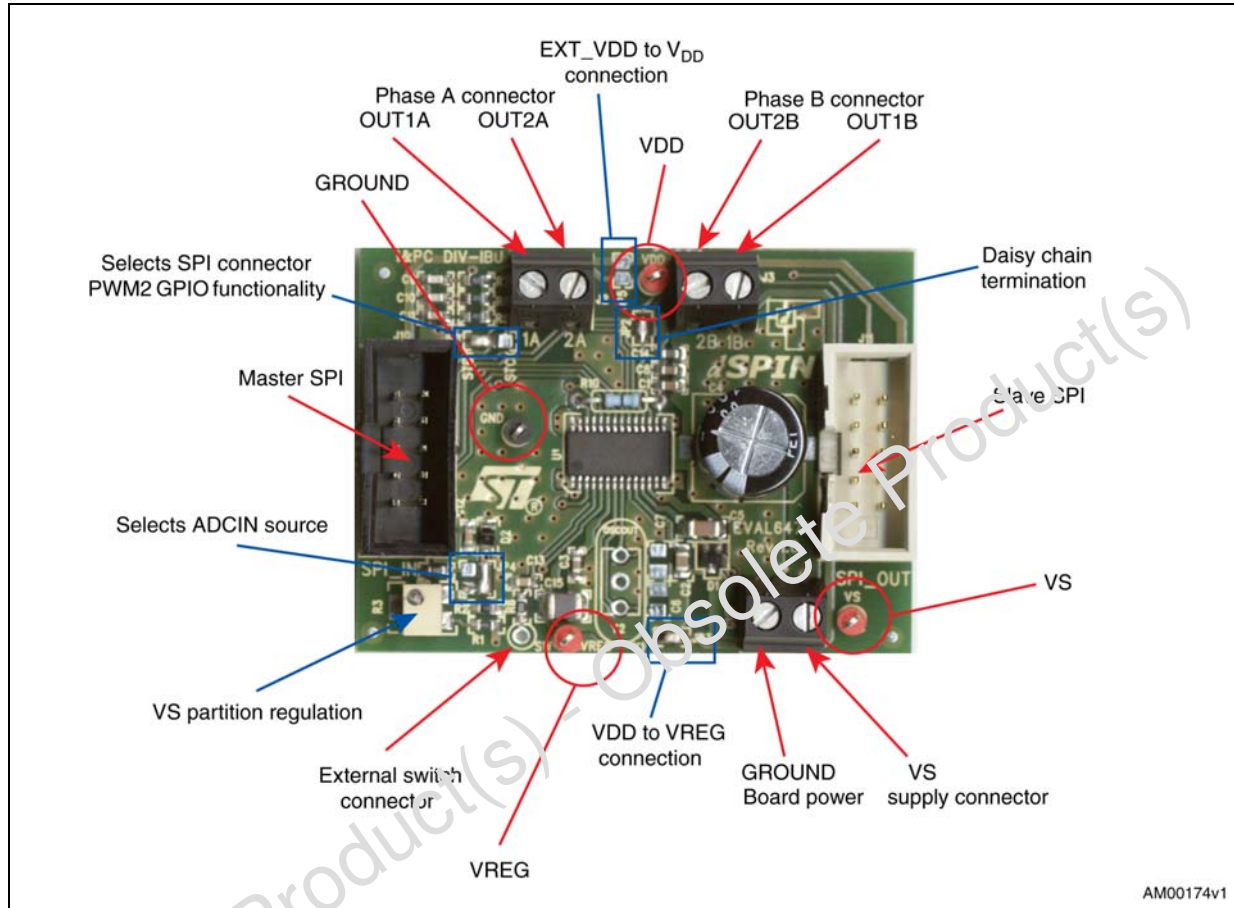

Table 1. EVAL6470: jumper and connector description

Name	Type	Function
J4	Power supply	Board power supply
J2	Power outputs	Bridge A outputs
J3	Power outputs	Bridge B outputs
J10	SPI connector	Master SPI connector
J11	SPI connector	Slave SPI connector
SW	NM test point	External switch connector
VS	Test point	Motor supply voltage
V _{REG}	Test point	Internal 3 V regulator output
V _{DD}	Test point	Logic interface voltage
GND	Test point	Ground
JP7	Jumper	Selects SPI connector PWM2 GPIO functionality
JP2	Jumper	Daisy chain termination
JP5	Jumper	EXT_VDD (SPI connector) to V _{DD} connection
JP3	Jumper	V _{DD} to V _{REG} connection
JP4	Jumper	Selects ADCIN source

Table 2. EVAL6470: master SPI connector pinout (J10)

Pin number	Description
1	L6470 BUSY open drain output
2	L6470 FLAG open drain output
3	Ground
4	EXT_VDD (can be used as external logic power supply)
5	SPI <i>master in, slave out</i> signal (connected to L6470 SDO output through daisy chain termination jumper JP2)
6	SPI serial clock signal (connected to L6470 CK input)
7	SPI <i>master out, slave in</i> signal (connected to L6470 SDI input)
8	SPI slave select signal (connected to L6470 CS input)
9	PWM1 input
10	PWM2 input

Table 3. EVAL6470: slave SPI connector pinout (J11)

Pin number	Description
1	L6470 BUSY open drain output
2	L6470 FLAG open drain output
3	Ground
4	EXT_VDD (can be used as external logic power supply)
5	SPI <i>master in, slave out</i> signal (connected to pin 5 of J10)
6	SPI serial clock signal (connected to L6470 CK input)
7	SPI <i>master out, slave in</i> signal (connected to L6470 SDO output)
8	SPI slave select signal (connected to L6470 CS input)
9	PWM1 input
10	PWM2 input

Table 4. EVAL6470: electrical specification (recommended values)

Parameter	Value
Supply voltage range (V_S)	8 to 45 V
Output current rating	Up to 3 A _{rms}
Logic supply voltage (V_{REG})	3.3 V (when externally supplied)
Logic interface voltage (V_{DD})	3.3 V or 5 V (when externally supplied)
Logic inputs voltage range	0 to +5 V
Operating temperature range	-25 to +125 °C
L6470H thermal resistance junction-to-ambient	40 °C/W

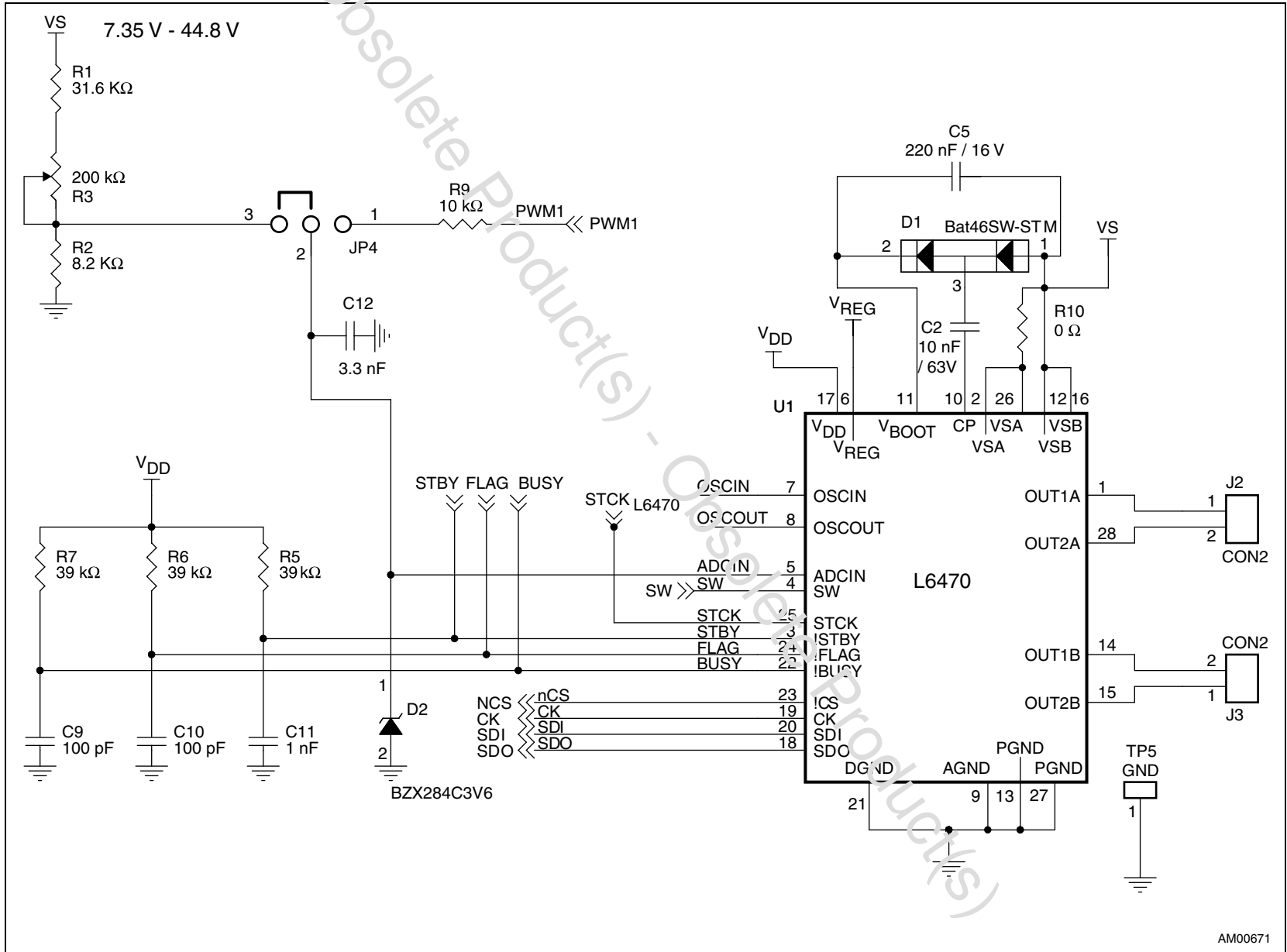

AM00671

Figure 2. EVAL6470 schematic - part 1

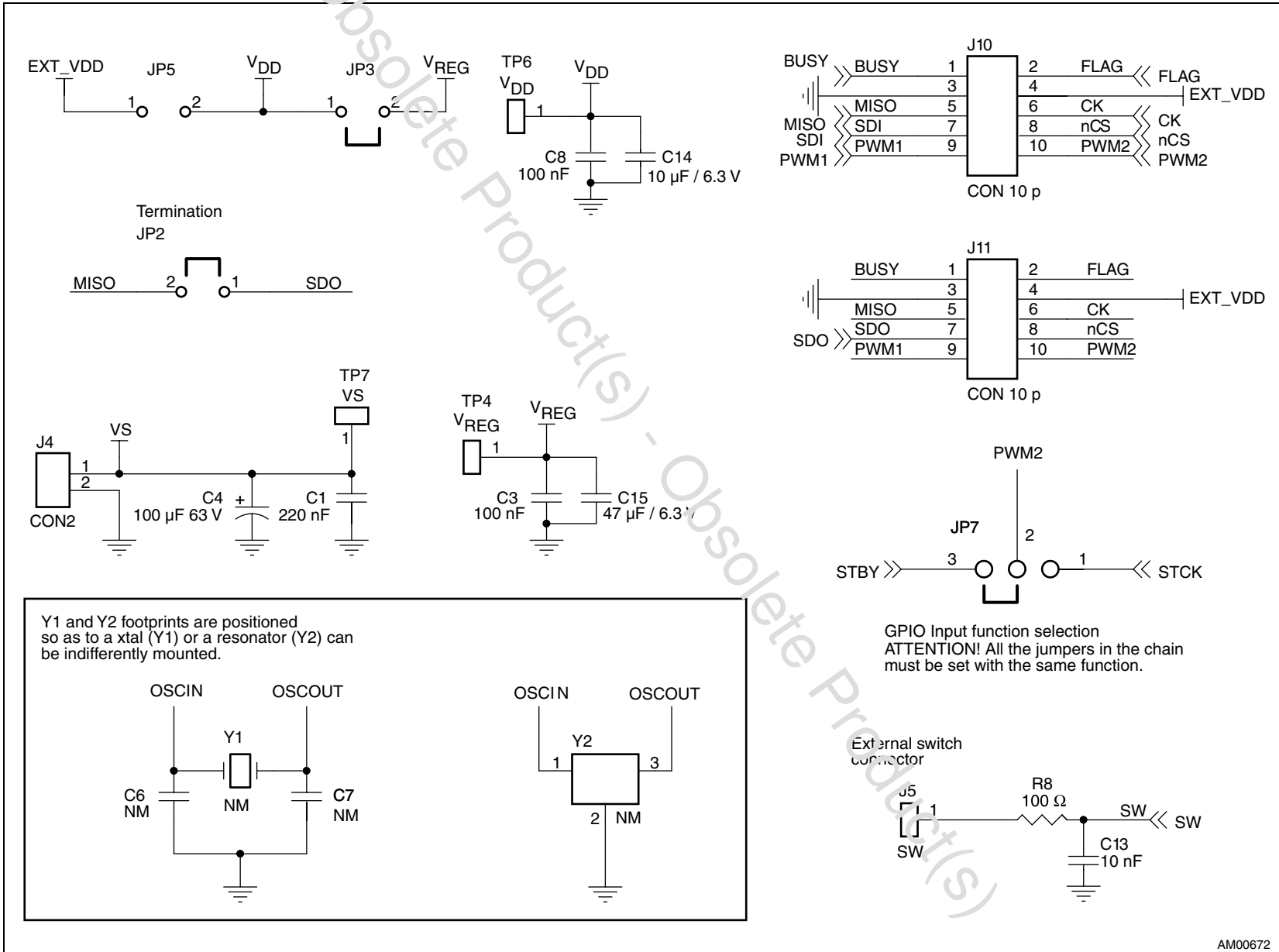

Y1 and Y2 footprints are positioned so as to a xtal (Y1) or a resonator (Y2) can be indifferently mounted.

GPIO Input function selection
ATTENTION! All the jumpers in the chain must be set with the same function.

Figure 3. EVAL6470 schematic - part 2

Table 5. EVAL6470: component list

Part reference	Part value	Part description
C1	100 nF	50 V ceramic capacitor
C2	10 nF	63 V ceramic capacitor
C3, C8	100 nF	Ceramic capacitor
C4	100 μ F	63 V electrolytic capacitor
C5	220 nF	16 V ceramic capacitor
C6, C7	NM	Ceramic capacitor
C9, C10	100 pF	Ceramic capacitor
C11	1 nF	Ceramic capacitor
C12	3.3 nF	Ceramic capacitor
C13	10 nF	Ceramic capacitor
C14	10 μ F	6.3 V ceramic capacitor
C15	47 μ F	6.3 V ceramic capacitor
D1	BAT46SW	Low drop diode couple
D2	BZX284C3V6	3.6 V Zener diode
JP2, JP3		Jumper 2 x 1
JP5		Jumper 2 x 1
JP4		Jumper 3 x 1
JP7		Jumper 3 x 1
J2, J3, J4		Connector
J5	NM	Strip pin
J10		Vertical 5 x 2 male connector
J11		Vertical 5 x 2 male connector
R1	31.6 k Ω	Resistor 1%
R2	8.2 k Ω	Resistor 1%
R5, R6, R7	39 k Ω	Resistor 1%
R9	10 k Ω	Resistor 1%
R3	200 k Ω	Trimmer
R8	100 Ω	Resistor 1%
R10	0 Ω	Resistor 1/8 W
TP5		Test point
TP4, TP6		Test point
U1	L6470H	L6470 dSPIN
Y1	NM	Crystal
Y2	NM	Ceramic resonator

Figure 4. EVAL6470 layout (top layer)

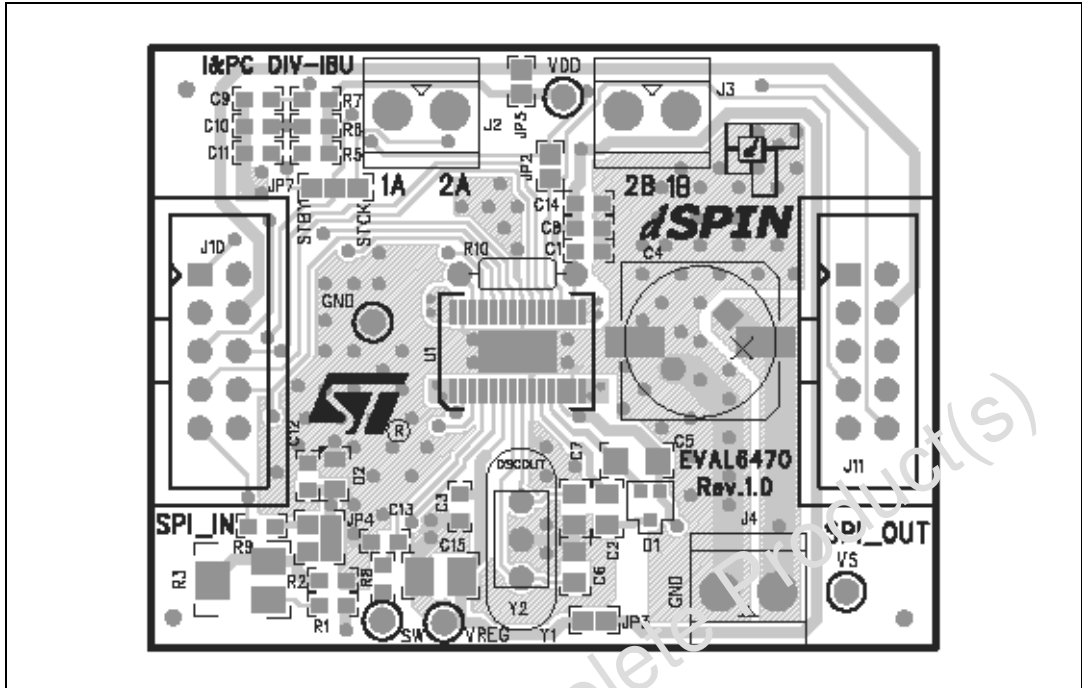
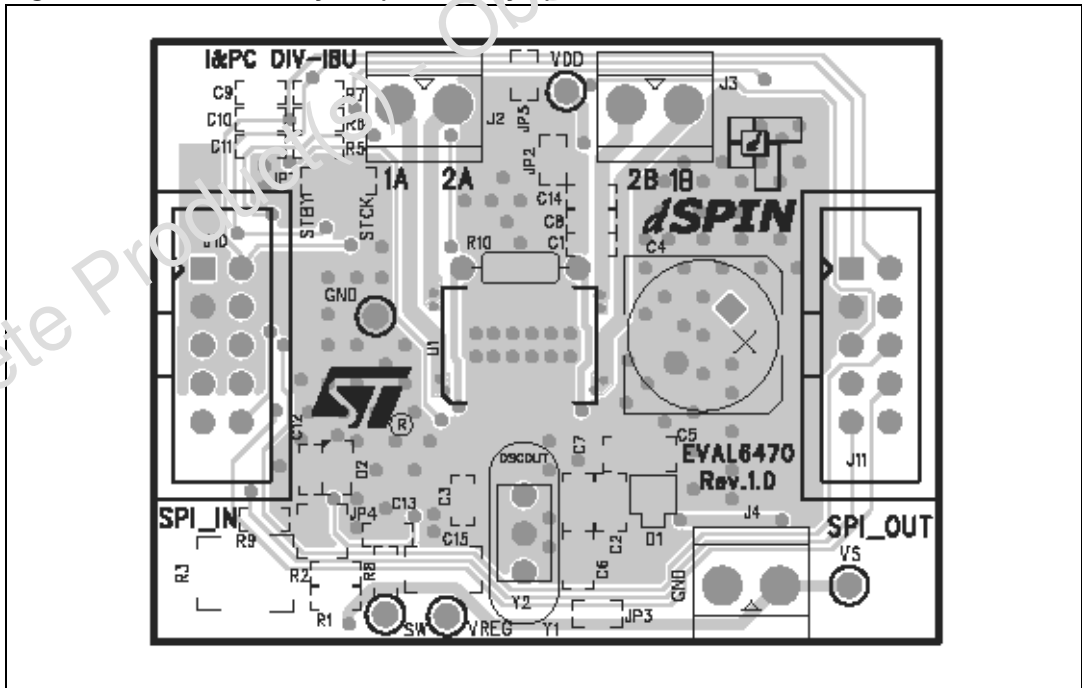

Figure 5. EVAL6470 layout (bottom layer)



2 Connection to IBU universal interface board

The EVAL6470 should be connected to the interface board (STEVAL-PCC009V2 or STEVAL-PCC009V1), and the following steps performed:

1. Connect the interface board to the PC through the USB cable
2. If requested, install interface board drivers
3. Verify interface board operation (check if operation LED diode is turned on)
4. Connect the interface board 10-pin connector to the EVAL6470 J10 connector (SPI_IN) through the 10-pole flat cable
5. Connect motor phases to the EVAL6470 J2 and J3 connectors
6. Connect the power supply (8 V to 45 V) to the EVAL6470 J4 connector
7. Start the dSPIN Evaluation tool.

2.1 Daisy-chain mode

More EVAL6470 boards can be connected in daisy chain mode. This way you can control up to eight motors using a single communication board (STEVAL-PCC009V2 only).

To drive two or more boards in daisy chain configuration:

1. Connect the interface board to the PC through the USB cable
2. If requested, install the interface board drivers
3. Verify interface board operation (check if the operation LED diode is turned on)
4. Connect the interface board 10-pin connector to the first EVAL6470 J10 connector (SPI_IN) through the 10-pole flat cable
5. Open the JP2 jumper of EVAL6470
6. Connect the J11 connector (SPI_OUT) of the previous EVAL6470 to the J10 connector (SPI_IN) of the next one through the 10-pole flat cable
7. Repeat point 5 and 6 for all the others board of the chain but the last one.
8. Check the JP2 jumpers of EVAL6470 boards: all the jumpers but the last one should be opened
9. Check the JP7 jumpers of EVAL6470 boards: all the jumpers should be in the same configuration (STCK or STBY)

Caution: Increasing the number of devices connected in chain could degrade SPI communication performances. If communication issues are founded, try to reduce SPI clock speed.

Figure 6. Daisy chain configuration

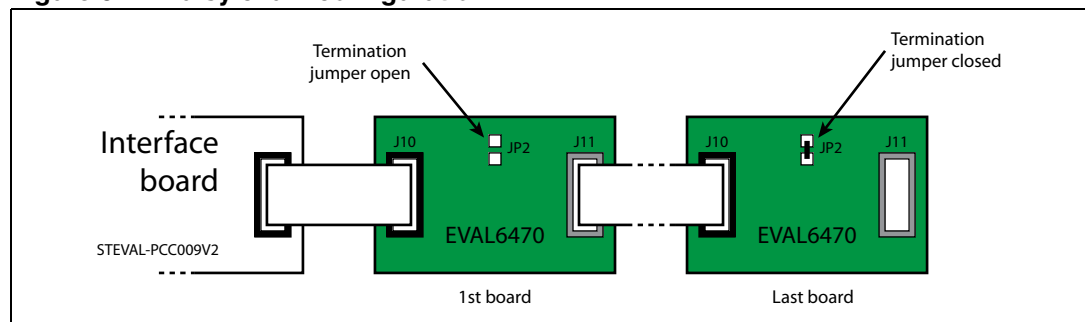

3 Revision history

Table 6. Document revision history

Date	Revision	Changes
22-Mar-2010	1	Initial release.

Obsolete Product(s) - Obsolete Product(s)

Please Read Carefully:

Information in this document is provided solely in connection with ST products. STMicroelectronics NV and its subsidiaries ("ST") reserve the right to make changes, corrections, modifications or improvements, to this document, and the products and services described herein at any time, without notice.

All ST products are sold pursuant to ST's terms and conditions of sale.

Purchasers are solely responsible for the choice, selection and use of the ST products and services described herein, and ST assumes no liability whatsoever relating to the choice, selection or use of the ST products and services described herein.

No license, express or implied, by estoppel or otherwise, to any intellectual property rights is granted under this document. If any part of this document refers to any third party products or services it shall not be deemed a license grant by ST for the use of such third party products or services, or any intellectual property contained therein or considered as a warranty covering the use in any manner whatsoever of such third party products or services or any intellectual property contained therein.

UNLESS OTHERWISE SET FORTH IN ST'S TERMS AND CONDITIONS OF SALE ST DISCLAIMS ANY EXPRESS OR IMPLIED WARRANTY WITH RESPECT TO THE USE AND/OR SALE OF ST PRODUCTS INCLUDING WITHOUT LIMITATION IMPLIED WARRANTIES OF MERCHANTABILITY, FITNESS FOR A PARTICULAR PURPOSE (AND THEIR EQUIVALENTS UNDER THE LAWS OF ANY JURISDICTION), OR INFRINGEMENT OF ANY PATENT, COPYRIGHT OR OTHER INTELLECTUAL PROPERTY RIGHT.

UNLESS EXPRESSLY APPROVED IN WRITING BY AN AUTHORIZED ST REPRESENTATIVE, ST PRODUCTS ARE NOT RECOMMENDED, AUTHORIZED OR WARRANTED FOR USE IN MILITARY, AIR CRAFT, SPACE, LIFE SAVING, OR LIFE SUSTAINING APPLICATIONS, NOR IN PRODUCTS OR SYSTEMS WHERE FAILURE OR MALFUNCTION MAY RESULT IN PERSONAL INJURY, DEATH, OR SEVERE PROPERTY OR ENVIRONMENTAL DAMAGE. ST PRODUCTS WHICH ARE NOT SPECIFIED AS "AUTOMOTIVE GRADE" MAY ONLY BE USED IN AUTOMOTIVE APPLICATIONS AT USER'S OWN RISK.

Resale of ST products with provisions different from the statements and/or technical features set forth in this document shall immediately void any warranty granted by ST for the ST product or service described herein and shall not create or extend in any manner whatsoever, any liability of ST.

ST and the ST logo are trademarks or registered trademarks of ST in various countries.

Information in this document supersedes and replaces all information previously supplied.

The ST logo is a registered trademark of STMicroelectronics. All other names are the property of their respective owners.

© 2011 STMicroelectronics - All rights reserved

STMicroelectronics group of companies

Australia - Belgium - Brazil - Canada - China - Czech Republic - Finland - France - Germany - Hong Kong - India - Israel - Italy - Japan - Malaysia - Malta - Morocco - Philippines - Singapore - Spain - Sweden - Switzerland - United Kingdom - United States of America

www.st.com