



Chipsmall Limited consists of a professional team with an average of over 10 year of expertise in the distribution of electronic components. Based in Hongkong, we have already established firm and mutual-benefit business relationships with customers from,Europe,America and south Asia,supplying obsolete and hard-to-find components to meet their specific needs.

With the principle of “Quality Parts,Customers Priority,Honest Operation,and Considerate Service”,our business mainly focus on the distribution of electronic components. Line cards we deal with include Microchip,ALPS,ROHM,Xilinx,Pulse,ON,Everlight and Freescale. Main products comprise IC,Modules,Potentiometer,IC Socket,Relay,Connector.Our parts cover such applications as commercial,industrial, and automotives areas.

We are looking forward to setting up business relationship with you and hope to provide you with the best service and solution. Let us make a better world for our industry!



## Contact us

Tel: +86-755-8981 8866 Fax: +86-755-8427 6832

Email & Skype: info@chipsmall.com Web: www.chipsmall.com

Address: A1208, Overseas Decoration Building, #122 Zhenhua RD., Futian, Shenzhen, China



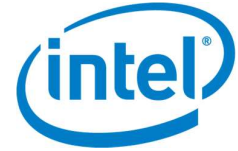

# Intel® Enpirion® Power Solutions

## EM2130x0xQI 30A PowerSoC

### Step-Down DC-DC Switching Converter with Integrated Inductor, Featuring Digital Control with PMBus™ v1.2 Compliant Interface

#### Description

The EM2130 is a fully integrated 30A PowerSoC synchronous buck converter. It features an advanced digital controller, gate drivers, synchronous MOSFET switches, and a high-performance inductor. Only input and output filter capacitors and a few small signal components are required for a complete solution. A PMBus version 1.2 compliant interface provides setup, control, and telemetry.

Differential remote sensing and  $\pm 0.5\%$  set-point accuracy provides precise regulation over line, load and temperature variation. Very low ripple further reduces accuracy uncertainty to provide best in class static regulation for today's FPGAs, ASICs, processors, and DDR memory devices.

The EM2130 may be used in standalone mode or utilizing the PMBus interface for a high degree of flexibility and programmability. Advanced digital control techniques ensure stability and excellent dynamic performance and eliminate the need for external compensation components. The PC-based Intel Enpirion Digital Power Configurator provides a user-friendly and easy-to-use interface to the device for communication and configuration.

The EM2130 features high conversion efficiency and superior thermal performance to minimize thermal de-rating limitations, which is key to product reliability and longevity.

#### Features

- Integrated inductor, FETs, and digital controller
- Wide 4.5V to 16V  $V_{IN}$  range
- 0.7V to 3.6V  $V_{OUT}$  range
- 30A continuous current with no thermal de-rating
- High efficiency in 11mm x 17mm x 6.76mm QFN package
  - 95% efficiency at  $V_{IN} = 5V$ ,  $V_{OUT} = 3.3V$
  - 90% efficiency at  $V_{IN} = 12V$ ,  $V_{OUT} = 1.2V$
- Optimized total solution size of only 365 mm<sup>2</sup>
- Meets all high-performance FPGA requirements
  - Digital loop for best in class transient response
  - 0.5% set-point over line, load, and temperature
  - Output ripple as low as 10 mV peak-peak
  - Differential remote sensing
  - Monotonic startup into pre-bias output
  - Optimized FPGA configs stored in NVM
- Programmable through PMBus™
  - $V_{OUT}$  margining, startup and shutdown delays
  - Programmable warnings, faults and response
- Ability to operate without PMBus™
  - RVSET resistor for programmable  $V_{OUT}$
  - RTUNE resistor for single resistor compensation
- Tracking pin for complex sequencing
- RoHS compliant, MSL level 3, 260°C reflow

#### Applications

- High performance FPGA supply rails
- ASIC and processor supply rails
- High density double data rate (DDR) memory VDDQ rails

## Ordering Information

Table 1

| Part Number   | Supported $V_{OUT}$ Range | Package Markings                   | $T_{AMBIENT}$ Rating (°C) | Package Description   |
|---------------|---------------------------|------------------------------------|---------------------------|---|
| EM2130L02QI   | 0.7V to 1.325V            | M2130L2                            | -40 to +85                | 17 mm x 11 mm x 6.76 mm QFN104 provided in 112 units per tray |
| EM2130H01QI   | 1.35V to 3.6V             | M2130H1                            | -40 to +85                | 17 mm x 11 mm x 6.76 mm QFN104 provided in 112 units per tray |
| EVB-EM2130L02 | 0.7V to 1.325V            | Evaluation board; 30A single phase |                           |   |
| EVB-EM2130H01 | 1.35V to 3.6V             | Evaluation board; 30A single phase |                           |   |
| EVI-EM2COMIF  | GUI interface dongle      |                                    |                           |   |

**Packing and Marking Information:** [www.altera.com/support/reliability/packing/rel-packing-and-marking.html](http://www.altera.com/support/reliability/packing/rel-packing-and-marking.html)

## Pin Assignments

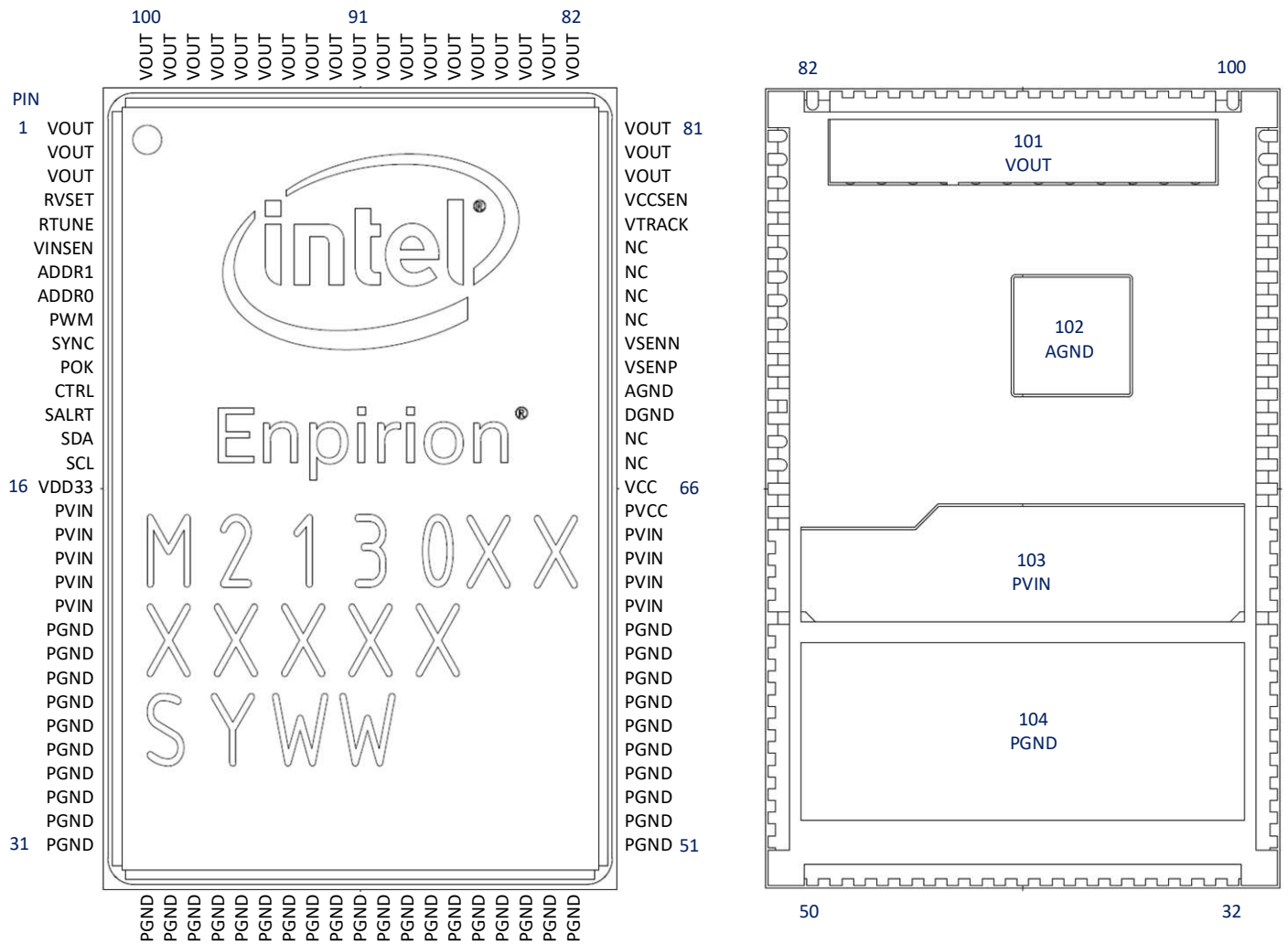

Figure 1: Pin Out Diagram

## Pin Description

Table 2

| PIN                     | NAME   | I/O              | FUNCTION  |
|-------------------------|--------|------------------|---|
| 1,2,3,<br>79-101        | VOUT   | Regulated Output | Regulated output voltage. Decouple to PGND with appropriate filter capacitors   |
| 4                       | RVSET  | Analog I/O       | A resistor from RVSET to AGND; and can be used to program the $V_{OUT}$ set-point. Using 1% tolerance or better resistor. See <a href="#">Table 8</a> and <a href="#">Table 9</a> for more information.                                       |
| 5                       | RTUNE  | Analog I/O       | A resistor from RTUNE to AGND; and can be used to tune the transient compensator for the amount of output capacitance. Using 1% tolerance or better resistor. See <a href="#">Table 10</a> and <a href="#">Table 11</a> for more information. |
| 6                       | VINSEN | Analog Input     | Single-ended input voltage sense (relative to AGND).  |
| 7                       | ADDR1  | Analog I/O       | A resistor from ADDR1 to AGND; and can be used to set the PMBus™ address. Use a 1% tolerance or better resistor.  |
| 8                       | ADDR0  | Analog I/O       | A resistor from ADDR0 to AGND; and can be used to set the PMBus™ address. Use a 1% tolerance or better resistor.  |
| 9                       | PWM    | PWM              | PWM signal test pin.  |
| 10                      | SYNC   | Digital I/O      | PWM synchronization signal  |
| 11                      | POK    | Digital I/O      | Power OK is selectable as a push-pull output or an open drain transistor for power system state indication. See the Power OK description for details.   |
| 12                      | CTRL   | Digital Input    | PMBus-compatible control pin with programmable functionality. CTRL should never be left floating if enabled in Configuration. The default configuration is for $V_{OUT}$ to be on with CTRL high (positive edge)                              |
| 13                      | SALRT  | Digital Output   | PMBus™ alert line.  |
| 14                      | SDA    | Digital I/O      | PMBus™ serial data I/O.   |
| 15                      | SCL    | Digital I/O      | PMBus™ serial clock input.  |
| 16                      | VDD33  | Output           | 3.3V output of the internal LDO. May be used as pull-up supply for PMBus™ pins and CTRL pin.  |
| 17-21,<br>61-64,<br>103 | PVIN   | Input Supply     | Input supply for MOSFET switches. Decouple to PGND with appropriate filter capacitors. Refer to Recommended Application Circuit section for more details.   |
| 22-60,<br>104           | PGND   | Ground           | Power ground. Ground for MOSFET switches.   |
| 65                      | PVCC   | Input Supply     | 5.0V supply voltage for driver circuitry. Decouple to GND using a 2.2 $\mu$ F MLCC high quality ceramic capacitor.  |
| 66                      | VCC    | Input Supply     | 5.0V supply voltage for analog circuitry.   |
| 67,68,<br>73-76         | NC     | NC               | No connect. Do not connect to any signal, supply, or ground.  |
| 69                      | DGND   | Ground           | Digital ground. Connect to AGND pin directly.   |

Data Sheet | Intel Enpirion Power Solutions: EM2130

| PIN     | NAME   | I/O          | FUNCTION   |
|---------|--------|--------------|--|
| 70, 102 | AGND   | Ground       | Analog ground. Connect to system ground plane. Refer to layout section for more details on grounding.  |
| 71      | VSENP  | Analog Input | Differential output voltage sense input (positive).  |
| 72      | VSENN  | Analog Input | Differential output voltage sense input (negative).  |
| 77      | VTRACK | Analog Input | Voltage tracking reference input if EM2130 is configured for voltage tracking mode. May remain floating if not used. <b>If enabled but not used, connect to VDD33 using a 10kΩ resistor.</b> VTRACK is not enabled in the default configuration. |
| 78      | VCCSEN | Analog Input | Single-ended VCC voltage sense (relative to AGND)  |

## Absolute Maximum Ratings

**CAUTION:** Absolute Maximum ratings are stress ratings only. Functional operation beyond the recommended operating conditions is not implied. Stress beyond the absolute maximum ratings may impair device life. Exposure to absolute maximum rated conditions for extended periods may affect device reliability. Voltage measurements are referenced to AGND.

### Absolute Maximum Pin Ratings

Table 3

| PARAMETER           | SYMBOL  | MIN  | MAX | UNITS |
|---------------------|---|------|-----|-------|
| Supply voltage PVIN | PVIN  | -0.3 | 18  | V     |
| Supply voltage VCC  | VCC   | -0.3 | 5.5 | V     |
| VCC ramp time       | VCC   |      | 20  | ms    |
| VDD33               | VDD33   | -0.3 | 3.6 | V     |
| Digital ground      | DGND  | -0.3 | 0.1 | V     |
| Power ground        | PGND  | -0.3 | 0.3 | V     |
| Digital I/O pins    | SALRT, POK, SYNC,                                     | -0.3 | 5.5 | V     |
| Digital I/O pins    | SCL, SDA, CTRL  | -0.3 | 3.6 | V     |
| Analog I/O pins     | VINSEN, VCCSEN, ADDR0, ADDR1,<br>RVSET, RTUNE, VTRACK | -0.3 | 2.0 | V     |
| Voltage feedback    | VSENP, VSENN  | -0.3 | 2.0 | V     |
| PWM pin             | PWM   | -0.3 | 5.5 | V     |
| Output voltage pins | VOUT  | -0.3 | 3.8 | V     |
| DC current on VOUT  | VOUT  |      | 35  | A     |

### Absolute Maximum Thermal Ratings

| PARAMETER                      | CONDITION     | MIN | MAX  | UNITS |
|--------------------------------|---------------|-----|------|-------|
| Operating junction temperature |               |     | +125 | °C    |
| Storage temperature range      |               | -65 | +150 | °C    |
| Reflow peak body temperature   | (10 Sec) MSL3 |     | +260 | °C    |

### Absolute Maximum ESD Ratings

| PARAMETER     | CONDITION                             | MIN  | MAX | UNITS |
|---------------|---------------------------------------|------|-----|-------|
| HBD           | All pins; Except VINSEN 1000 V<br>Max | 2000 |     | V     |
| CDM; all pins |                                       | 500  |     | V     |

## Recommended Operating Conditions

Table 4

| PARAMETER                           | PINS      | MIN  | MAX  | UNITS |
|-------------------------------------|-----------|------|------|-------|
| PVIN supply voltage range           | PVIN      | 4.5  | 16   | V     |
| Supply voltage $V_{CC}$ & $PV_{CC}$ | VCC, PVCC | 4.75 | 5.25 | V     |
| Continuous load current             | $V_{OUT}$ |      | 30   | A     |

## Thermal Characteristics

Table 5

| PARAMETER   | PINS          | TYPICAL | UNITS |
|---|---------------|---------|-------|
| Thermal shutdown [programmable]                             | $T_{SD}$      | 120     | °C    |
| Thermal shutdown Hysteresis                                 | $T_{SDH}$     | 18      | °C    |
| Thermal resistance: junction to ambient (0 LFM)<br>(Note 1) | $\theta_{JA}$ | 8       | °C/W  |
| Thermal resistance: junction to case bottom (0 LFM)         | $\theta_{JC}$ | 1.5     | °C/W  |

**Note 1:** Based on 2 oz. external copper layers and proper thermal design in line with EIJ/JEDEC JESD51 standards for high thermal conductivity boards. No top side cooling required.



## Electrical Characteristics

$PV_{IN} = 12V$  and  $V_{CC} = 5.0V$ . The minimum and maximum values are over the operating ambient temperature range (-40°C to 85°C) unless otherwise noted. Typical values are at  $T_A = 25^\circ C$ .

**Table 6**

| PARAMETER                                  | SYMBOL | TEST CONDITIONS   | MIN  | TYP | MAX     | UNITS   |
|--|--------|---|------|-----|---------|---------|
| <b>SUPPLY CHARACTERISTICS</b>              |        |   |      |     |         |         |
| PVIN supply voltage range                  | PVIN   |   | 4.5  |     | 16      | V       |
| PVIN supply quiescent current              |        | Device switching; no load; $f_{sw} = 800$ kHz; $V_{OUT} = 1.0V$ |      | 40  |         | mA      |
|  |        | Device not switching  |      | 1   |         |         |
| VCC supply voltage range                   | VCC    |   | 4.75 | 5.0 | 5.25    | V       |
| VCC UVLO rising                            |        |   |      | 4.4 |         | V       |
| VCC UVLO falling                           |        |   |      | 4.2 |         | V       |
| PVcc & VCC supply current                  |        | Normal operation; no load; $f_{sw} = 800$ kHz                   |      | 80  |         | mA      |
|  |        | Normal operation; no load; $f_{sw} = 1.33$ MHz                  |      | 120 |         | mA      |
|  |        | Idle; communication and telemetry only; no switching            |      | 30  |         | mA      |
|  |        | Disabled ( $V_{CC} \leq 2.8V$ )                                 |      | 900 |         | $\mu A$ |
| <b>INTERNALLY GENERATED SUPPLY VOLTAGE</b> |        |   |      |     |         |         |
| VDD33 voltage range                        | VDD33  |   | 3.0  | 3.3 | 3.6     |         |
| VDD33 output current                       |        |   |      |     | 2       | mA      |
| <b>DIGITAL I/O PINS (POK, SYNC)</b>        |        |   |      |     |         |         |
| Input high voltage                         |        |   | 2.0  |     | 5.5     | V       |
| Input low voltage                          |        |   | 0    |     | 0.8     | V       |
| Output high voltage                        |        |   | 2.4  |     | VDD33   | V       |
| Output low voltage                         |        |   |      |     | 0.4     | V       |
| Input leakage current                      |        |   |      |     | $\pm 1$ | $\mu A$ |
| Output current - source                    |        |   |      |     | 2.0     | mA      |
| Output current - sink                      |        |   |      |     | 2.0     | mA      |
| <b>DIGITAL I/O PIN (CTRL)</b>              |        |   |      |     |         |         |
| Input high voltage                         |        |   | 2.0  |     | 3.6     | V       |
| Input low voltage                          |        |   | -0.3 |     | 0.8     | V       |

| PARAMETER   | SYMBOL   | TEST CONDITIONS   | MIN  | TYP   | MAX   | UNITS |
|---|----------|---|------|-------|-------|-------|
| CTRL response delay (stop)                                |          | Configurable polarity; extra turn-off delay configurable (assumes 0 s turn-off delay)   |      | 150   |       | μs    |
| CTRL response delay (start)                               |          | Configurable polarity; extra turn-on delay configurable (assumes 0 s turn-on delay)   |      | 250   |       | μs    |
| <b>HKADC INPUT PINS (VINSEN, VCCSEN, ADDR0 AND ADDR1)</b> |          |   |      |       |       |       |
| Input voltage   |          |   | 0    |       | 1.44  | V     |
| <b>PWM AND SYNCHRONIZATION</b>                            |          |   |      |       |       |       |
| PWM output voltage - high                                 |          |   | 2.4  |       |       | V     |
| PWM output voltage - low                                  |          |   |      |       | 0.4   | V     |
| PWM tristate leakage                                      |          |   |      |       | ±1    | μA    |
| PWM pulse width   |          |   | 30   |       |       | ns    |
| Resolution  |          |   |      | 163   |       | ps    |
| Switching frequency – EM2130L                             | $f_{sw}$ | With internal oscillator  |      | 800   |       | kHz   |
| Switching frequency – EM2130H                             | $f_{sw}$ | With internal oscillator  |      | 1333  |       | kHz   |
| SYNC frequency range                                      |          | Percent of nominal switching frequency  |      |       | ±12.5 | %     |
| SYNC pulse width  |          |   | 25   |       |       | ns    |
| <b>OUTPUT VOLTAGE SENSE, REPORTING, AND MANAGEMENT</b>    |          |   |      |       |       |       |
| Output voltage adjustment range                           | EM2130L  |   | 0.7  |       | 1.325 | V     |
|   | EM2130H  |   | 1.35 |       | 3.6   | V     |
| Output voltage set-point accuracy                         | EM2130L  | $0^{\circ}\text{C} < T_A < 85^{\circ}\text{C}$  | -0.5 |       | +0.5  | %     |
|   | EM2130L  | $-40^{\circ}\text{C} < T_A < 85^{\circ}\text{C}$  | -1   |       | +1    | %     |
|   | EM2130H  | $-40^{\circ}\text{C} < T_A < 85^{\circ}\text{C}$  | -1   |       | +1    | %     |
| Output set-point resolution                               | EM2130L  |   |      | 1.5   |       | mV    |
| Line regulation   |          |   |      | 0.007 |       | mV/V  |
| Load regulation   |          |   |      | 0.07  |       | mV/A  |
| Output voltage startup delay                              |          | From $V_{CC}$ valid, to start of output voltage ramp, if configured to regulate from power on reset, and TON_DELAY is set to 0. |      | 5     |       | ms    |

| PARAMETER  | SYMBOL | TEST CONDITIONS                                       | MIN  | TYP  | MAX | UNITS |
|--|--------|---|------|------|-----|-------|
| Output voltage ramp delay (TON_DELAY & TOFF_DELAY)     |        | Configurable, no V <sub>OUT</sub> pre-bias condition. | 0    |      | 500 | ms    |
| VTRACK ramp rate                                       |        |   |      |      | 2.0 | V/ms  |
| VTRACK range   |        | Without resistor divider                              | 0    |      | 1.4 | V     |
| VTRACK offset voltage                                  |        |   |      | ±100 |     | mV    |
| <b>OUTPUT CURRENT SENSE, REPORTING, AND MANAGEMENT</b> |        |   |      |      |     |       |
| Current sense reporting accuracy                       |        | I <sub>OUT</sub> > 5A, 25°C ≤ T <sub>A</sub> < 85°C   |      | ±1.5 |     | A     |
|  |        | I <sub>OUT</sub> > 5A, T <sub>A</sub> = 25°C          |      | ±1   |     | A     |
| <b>TEMPERATURE SENSE, REPORTING, AND MANAGEMENT</b>    |        |   |      |      |     |       |
| Temperature reporting accuracy                         |        |   |      | ±5   |     | °C    |
| Resolution   |        |   |      | 0.22 |     | °C    |
| <b>FAULT MANAGEMENT PROTECTION FEATURES</b>            |        |   |      |      |     |       |
| PV <sub>IN</sub> UV threshold                          |        |   |      | 3.96 |     | V     |
| PVIN OV threshold                                      |        |   |      | 16.5 |     | V     |
| V <sub>OUT</sub> OV threshold                          |        | Percentage of output voltage                          |      | 115  |     | %     |
| V <sub>OUT</sub> UV threshold                          |        | Percentage of output voltage                          |      | 85   |     | %     |
| I <sub>OUT</sub> OCP                                   |        | With 45A OCP setting                                  | 40   |      | 50  | A     |
| OTP threshold  |        |   |      | 120  |     | °C    |
| OTP hysteresis   |        | Fixed.  |      | 85   |     | %     |
| POK threshold  |        | On level  |      | 95   |     | %     |
| POK threshold  |        | Off level   |      | 90   |     | %     |
| Watchdog Timer Interval                                |        |   |      |      | 3   | ms    |
| <b>SERIAL COMMUNICATION PMBUS DC CHARACTERISTICS</b>   |        |   |      |      |     |       |
| Input voltage – high (VIH)                             |        | SCL and SDA   | 1.11 |      |     | V     |
| Input voltage – low (VIL)                              |        | SCL and SDA   |      |      | 0.8 | V     |
| Rise & Fall Time                                       |        | SCL and SDA >0.8V<1.1V                                |      |      | 2   | ms    |
| Input leakage current                                  |        | SCL, SDA, SALRT, and CTRL.                            | -10  |      | 10  | µA    |
| Output voltage – low (VOL)                             |        | SDA and SALRT at rated pull-up current of 20mA.       |      |      | 0.4 | V     |
| Nominal bus voltage                                    |        | SCL, SDA, and SALRT termination voltage.              | 1.62 |      | 3.6 | V     |

## Typical Performance Characteristics

All the performance curves are measured with EM2130 evaluation board at 25°C ambient temperature unless otherwise noted. The output capacitors configuration for the evaluation board is 2 x 470 μF (3 mΩ ESR) + 4 x 100 μF (Ceramic) + 4 x 47 μF (Ceramic) for EM2130L and 2 x 220 μF (5 mΩ ESR) + 6 x 47 μF (Ceramic) for EM2130H.

Efficiency,  $V_{IN} = 12V$

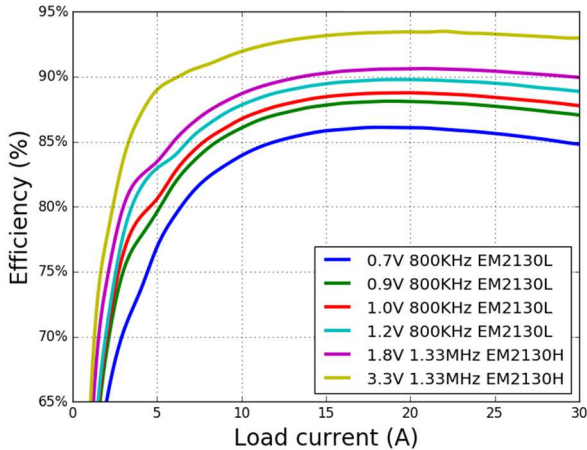

Efficiency,  $V_{IN} = 5V$

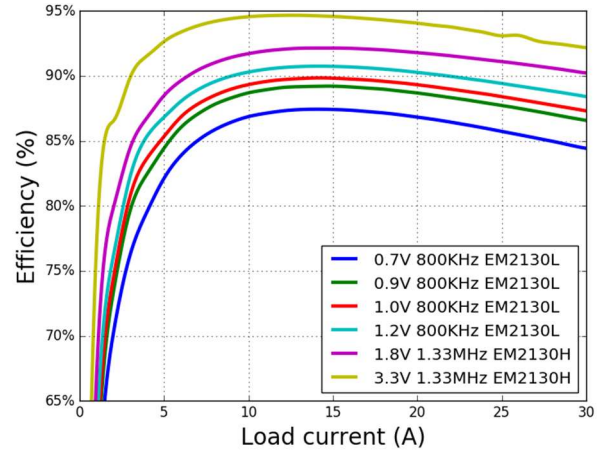

EM2130L Thermal Derating, No Airflow

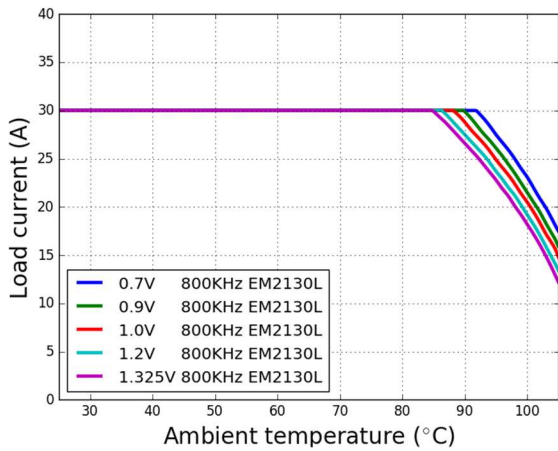

EM2130H Thermal Derating, No Airflow

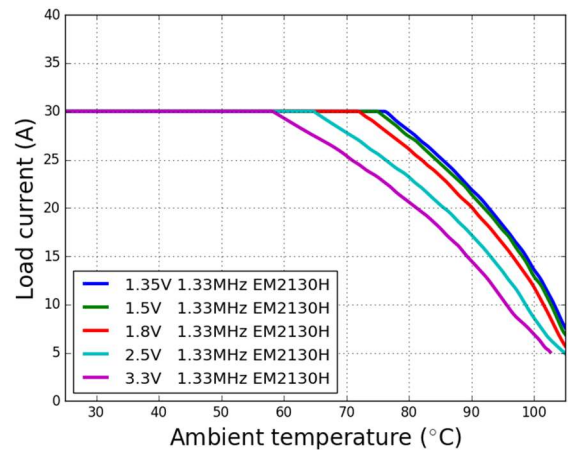

EM2130L Line Regulation,  $V_{OUT} = 0.9V$

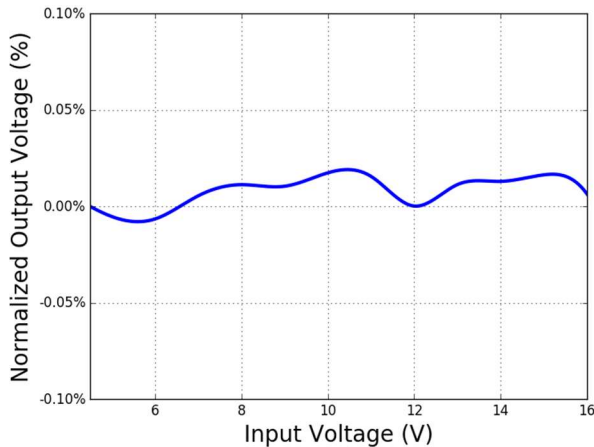

EM2130L Load Regulation,  $V_{OUT} = 0.9V$

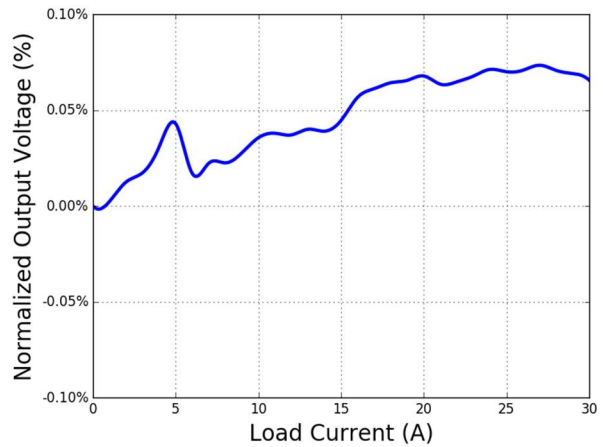

## Typical Performance Characteristics (Continued)

Start-up/Shutdown, PVIN At No Load,  
20 ms/div

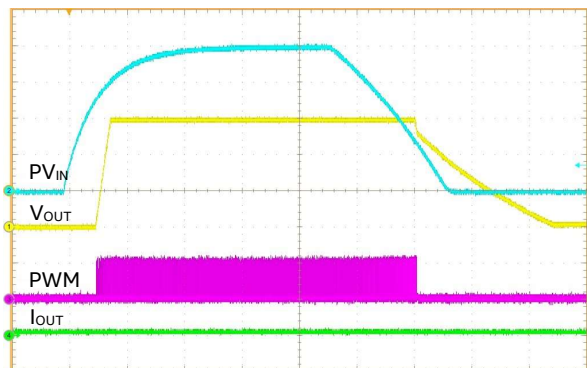

PV<sub>IN</sub> and PWM: 3 V/div,  
V<sub>OUT</sub>: 300 mV/div, I<sub>OUT</sub>: 10 A/div

Start-up/Shutdown, PVIN At 30A Load,  
20 ms/div

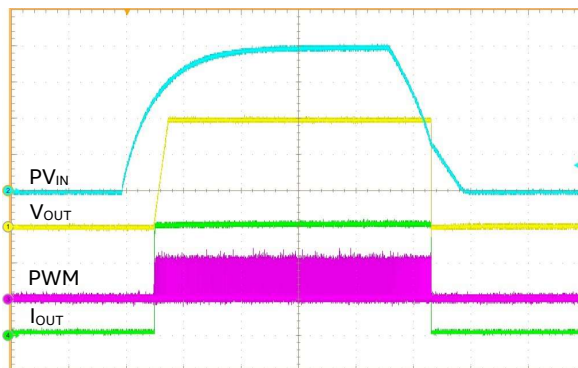

PV<sub>IN</sub> and PWM: 3 V/div,  
V<sub>OUT</sub>: 300 mV/div, I<sub>OUT</sub>: 10 A/div

Start-up/Shutdown, CTRL At No Load,  
5 ms/div

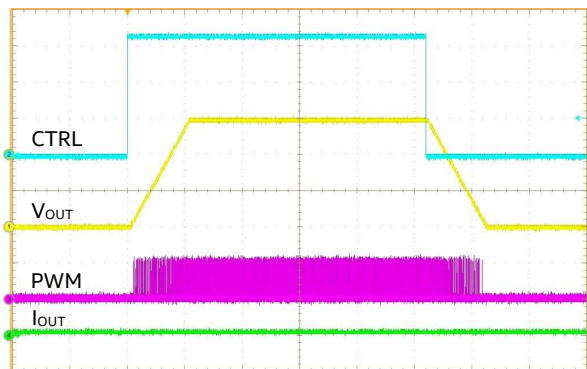

CTRL: 1 V/div, PWM: 3 V/div,  
V<sub>OUT</sub>: 300 mV/div, I<sub>OUT</sub>: 10 A/div

Start-up/Shutdown, CTRL At 30A Load,  
5 ms/div

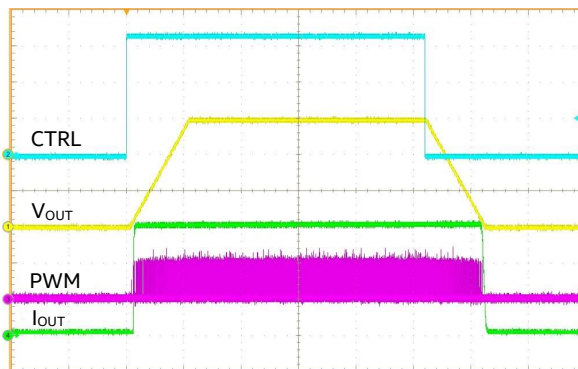

CTRL: 1 V/div, PWM: 3 V/div,  
V<sub>OUT</sub>: 300 mV/div, I<sub>OUT</sub>: 10 A/div

Start-up Into 0.6V Pre-Bias With PVIN,  
5 ms/div

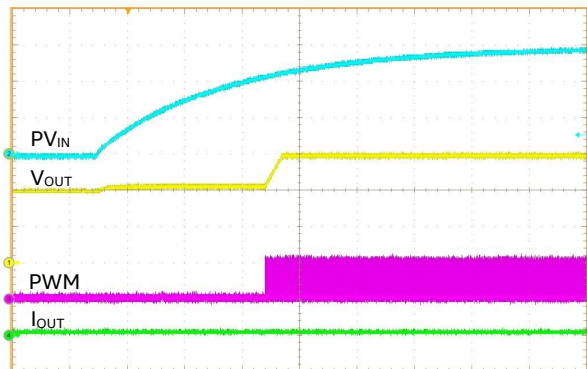

PV<sub>IN</sub>: 3 V/div, PWM: 3 V/div,  
V<sub>OUT</sub>: 300 mV/div, I<sub>OUT</sub>: 10 A/div

Start-up Into 0.6V Pre-Bias With CTRL,  
5 ms/div

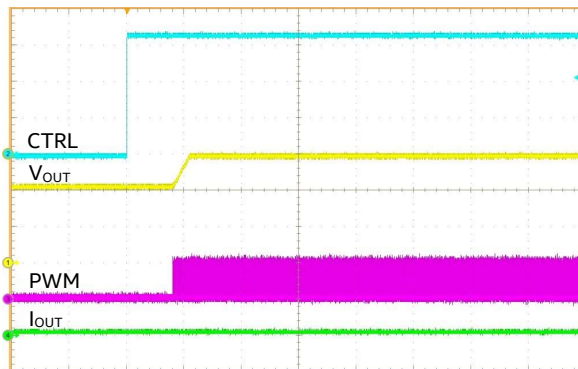

CTRL: 1 V/div, PWM: 3 V/div,  
V<sub>OUT</sub>: 300 mV/div, I<sub>OUT</sub>: 10 A/div

## Typical Performance Characteristics (Continued)

**Output Voltage Ripple,  
No Load**

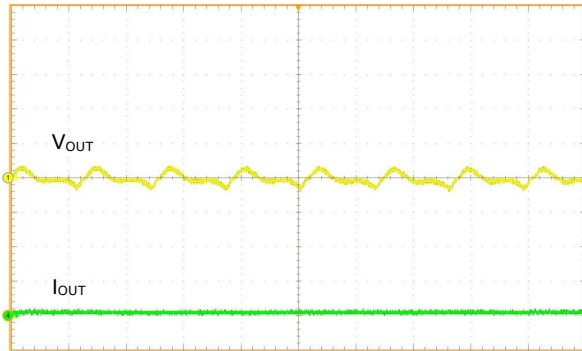

$V_{IN} = 12V, V_{OUT} = 0.9V$   
 $1 \mu s/div, V_{OUT}: 10 mV/div, 20 MHz$  bandwidth

**Output Voltage Ripple,  
30A Load**

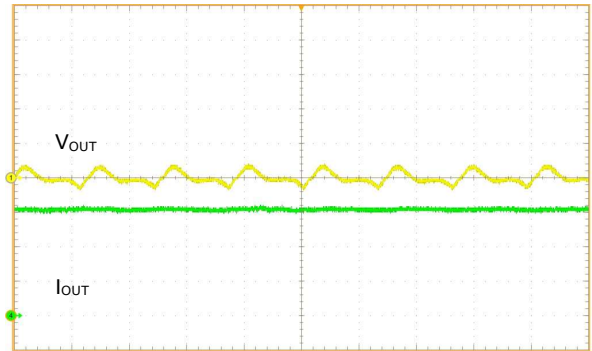

$V_{IN} = 12V, V_{OUT} = 0.9V$   
 $1 \mu s/div, V_{OUT}: 10 mV/div, 20 MHz$  bandwidth

**Output Voltage Transient Response,  
Load Step From 0A To 15A**

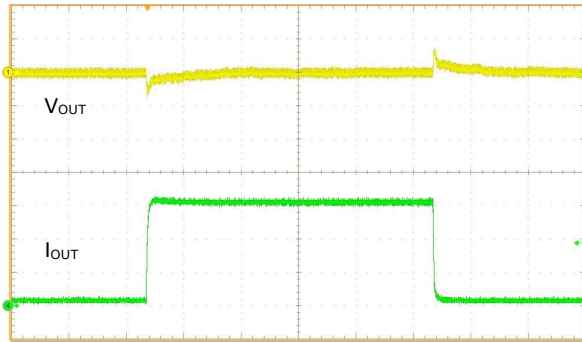

$V_{IN} = 12V, V_{OUT} = 0.9V, 100 \mu s/div$   
 $V_{OUT}: 30 mV/div, I_{OUT}: 5 A/div, 15 A/\mu s$

**Output Voltage Transient Response,  
Load Step From 15A To 30A**

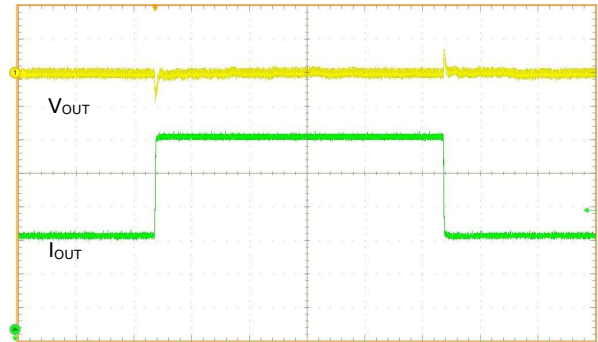

$V_{IN} = 12V, V_{OUT} = 0.9V, 100 \mu s/div$   
 $V_{OUT}: 30 mV/div, I_{OUT}: 5 A/div, 15 A/\mu s$

**Output Voltage Transient Response,  
Load Step From 0A To 15A**

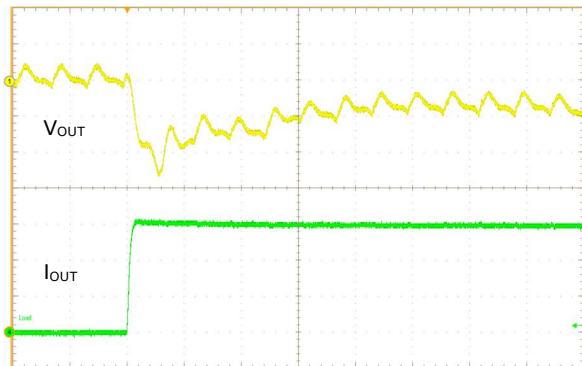

$V_{IN} = 12V, V_{OUT} = 0.9V, 2 \mu s/div$   
 $V_{OUT}: 10 mV/div, I_{OUT}: 5 A/div, 100 A/\mu s$

**Output Voltage Transient Response,  
Load Step From 0A To 15A**

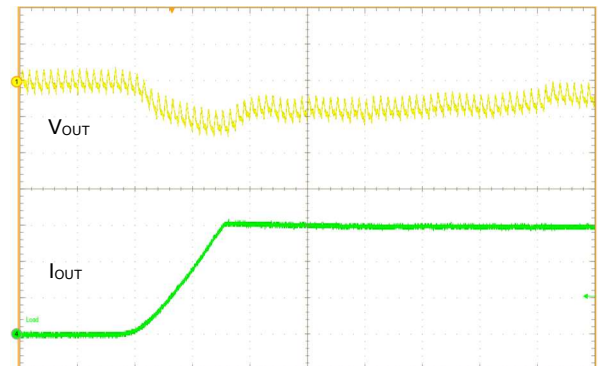

$V_{IN} = 12V, V_{OUT} = 0.9V, 10 \mu s/div$   
 $V_{OUT}: 10 mV/div, I_{OUT}: 5 A/div, 1 A/\mu s$

## Functional Block Diagram

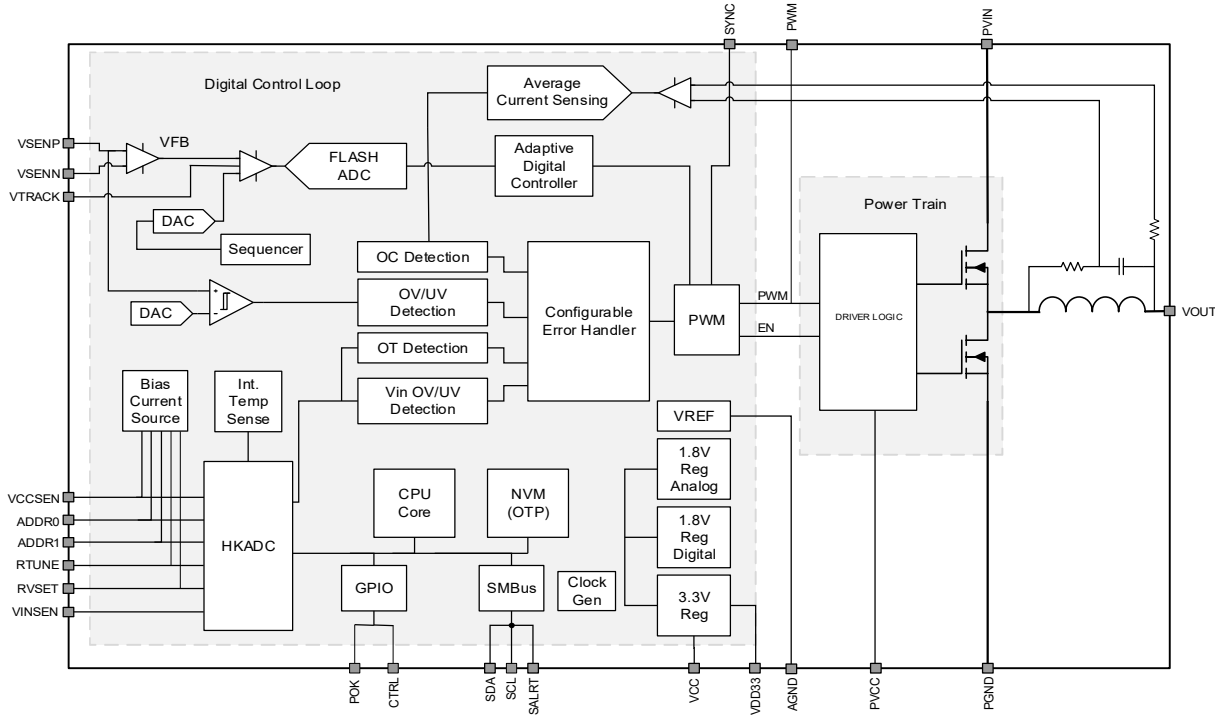

Figure 2: Functional Block Diagram

## Functional Description

### FUNCTIONAL DESCRIPTION: DEFAULT CONFIGURATION

The EM2130 is a single output digital PowerSoC synchronous step-down converter with advanced digital control techniques, capable of supplying up to 30A of continuous output current. The PowerSoC includes integrated power MOSFETs, a high-performance inductor and a digital controller which offers a PMBus version 1.2 compliant interface to support an extensive suite of telemetry, configuration and control commands.

In the default configuration, the EM2130 requires only two resistors total to set the output voltage and set the digital compensator for the most optimized performance. This easy-to-use default configuration allows the user to tune the EM2130 to meet the most demanding accuracy and load transient requirements without requiring any programming or digital interface. The following sections describe the default configuration. Refer to the Advanced Configuration section for details on the many ways the EM2130 may be customized and configured through the PMBus interface.

In order to optimize size versus efficiency over a wide range of operating conditions, there are two module variants – a low output voltage variant EM2130L ( $0.7V \leq V_{OUT} \leq 1.325V$ ) which operates at 800KHz and a high output voltage variant EM2130H ( $1.35V \leq V_{OUT} \leq 3.6V$ ) which operates at 1.33MHz.

The advanced digital control loop works as a voltage-mode controller using a PID-type compensation. The basic structure of the controller is shown in Figure 3. The EM2130 controller features two PID compensators for steady-state operation and fast transient operation. Fast, reliable switching between the different compensation modes ensures good transient performance and quiet steady state performance. The EM2130 has been pre-programmed with a range of default compensation coefficients which lets the

user select the best compensation for the best transient response and stability for the output capacitance of the system.

The EM2130 uses two additional technologies to improve transient performance. First, the EM2130 uses over-sampling techniques to acquire fast, accurate, and continuous information about the output voltage so that the device can react quickly to any changes in output voltage. Second, a non-linear gain adjustment is applied during large load transients to boost the loop gain and reduce the settling time.

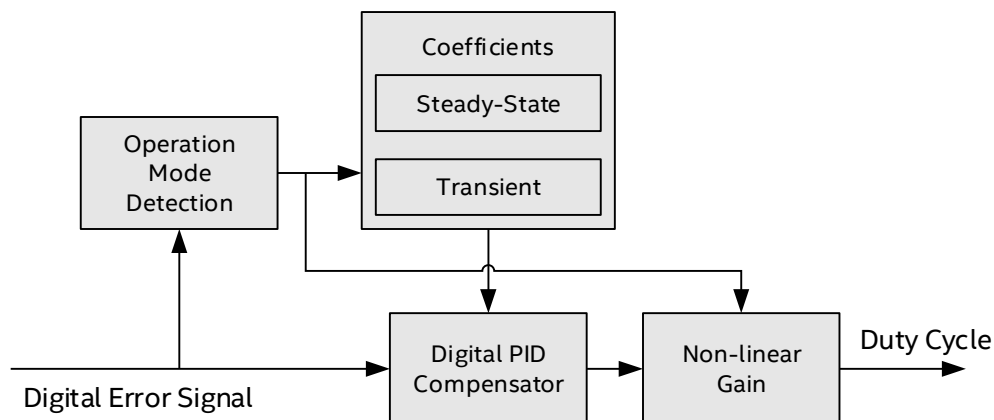

**Figure 3: Simplified Block Diagram Of The Digital Compensation**

In the default configuration, the EM2130 offers a complete suite of fault warnings and protections. Input and output Under Voltage Lock-Out (UVLO) and Over Voltage Lock-Out (OVLO) conditions are continuously monitored. A dedicated ADC is used to provide fast and accurate current information over the switching period allowing for fast Over-Current Protection (OCP) response. Over Temperature Protection (OTP) is accomplished by direct monitoring of the device's internal temperature.

## POWER ON RESET

The EM2130 employs an internal power-on-reset (POR) circuit to ensure proper start-up and shut down with a changing supply voltage. Once the VCC supply voltage increases above the POR threshold voltage, the EM2130 begins the internal start-up process. Upon its completion, the device is ready for operation.

Two separate input voltage supplies are necessary to operate, PVIN (4.5V to 16V) and V<sub>CC</sub> (4.75V to 5.25V). Both of these voltage rails must be monitored for proper power-up and to protect the power MOSFETs under various input power fault conditions. A voltage divider on each input voltage supply connected to V<sub>INSEN</sub> for the power rail (PVIN) and V<sub>CCSEN</sub> for the supply rail (VC) is used for digital monitoring of the supplies.

As illustrated in [Figure 4](#), the values of resistors R1, R2, R3 and R4 are chosen so the internal monitor ADC does not saturate within the appropriate ranges. This allows the EM2130 telemetry to report when the recommended operation voltage has been exceeded.

It is mandatory that the listed resistors values are used in order to ensure proper operation with the EM2130 default configuration. The resistors used must be R1=11 kΩ, R2=1 kΩ, R3=10 kΩ and R4=3.3 kΩ, using 1% tolerance or better resistors. If these values are not used then the EM2130 will read incorrect values for both PVIN and VCC.

Digital filtering is provided inside the EM2130 but if additional filtering is needed due to high noise on either rail, a capacitor can be connected between each pin (V<sub>INSEN</sub> & V<sub>CCSEN</sub>) and ground to maintain high accuracy.



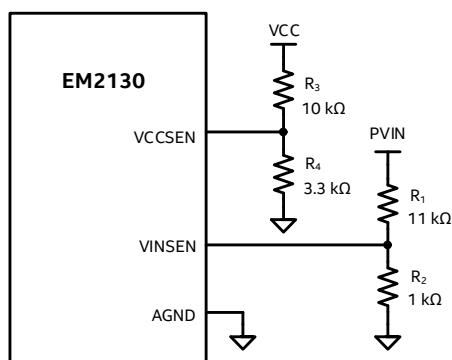

Figure 4: VINSEN And VCCSEN Input Resistor Dividers

The EM2130 also uses the PVIN monitor for input voltage feed-forward, which eliminates variations in the output voltage due to sudden changes in the input voltage supply. It does this by immediately changing the duty cycle to compensate for the input supply variation by normalizing the DC gain of the loop.

### SETTING THE OUTPUT VOLTAGE

Differential remote sensing provides for precise regulation at the point of load. One of thirty output voltages may be selected in the default configuration, based on a resistor connected to the RVSET pin. At power-up, an internal current source biases the resistor and the voltage is measured by an ADC to decode the V<sub>OUT</sub> selection. Use the RVSET tables (Table 8 and Table 9) for the details of V<sub>OUT</sub> selection and RVSET values.

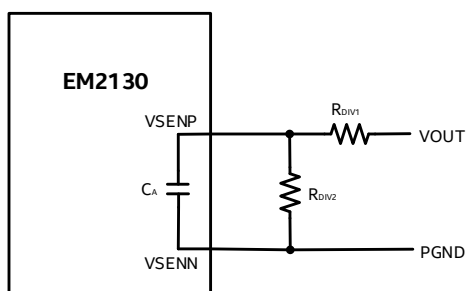

Figure 5: Output Voltage Sense Circuitry

The digital control loop ADC of the low voltage EM2130L supports direct output voltage feedback connection over the entire V<sub>OUT</sub> range. For the high output voltage EM2130H, a feedback divider is required as shown in Figure 5. The resistor values in Table 7 are required as a function of the output voltage selection. It is mandatory that the listed resistor values are used, use of other values may result in poor regulation performance as these values are expected in the EM2130 default configuration. Resistors with tight tolerances are recommended to maintain output voltage accuracy.

The resistors in the feedback path also form a low-pass filter with the internal capacitor, C<sub>A</sub>, for removing high-frequency disturbances from the sense signals. Place these components as close as possible to the EM2130 for best filtering performance.

Table 7: Output Voltage Feedback Component

| Module    | V <sub>OUT</sub>                 | R <sub>DIV1</sub> | R <sub>DIV2</sub> |
|-----------|----------------------------------|-------------------|-------------------|
| EM2130Lxx | 0.7V ≤ V <sub>OUT</sub> ≤ 1.325V | 2 kΩ              | Open              |
| EM2130Hxx | 1.35V ≤ V <sub>OUT</sub> ≤ 2.6V  | 2 kΩ              | 2 kΩ              |
| EM2130Hxx | 2.7V ≤ V <sub>OUT</sub> ≤ 3.6V   | 2 kΩ              | 1 kΩ              |

**Table 8: Supported Configuration Voltage Values For EM2130L Output Voltage**

| RVSET Resistor | V <sub>OUT</sub> | External Resistor Divider                         |
|----------------|------------------|---|
| 0kΩ            | Reserved         | R <sub>1DIV</sub> = 2kΩ, R <sub>2DIV</sub> = open |
| 0.392kΩ        | Reserved         | R <sub>1DIV</sub> = 2kΩ, R <sub>2DIV</sub> = open |
| 0.576kΩ        | Reserved         | R <sub>1DIV</sub> = 2kΩ, R <sub>2DIV</sub> = open |
| 0.787kΩ        | Reserved         | R <sub>1DIV</sub> = 2kΩ, R <sub>2DIV</sub> = open |
| 1.000kΩ        | 1.325V           | R <sub>1DIV</sub> = 2kΩ, R <sub>2DIV</sub> = open |
| 1.240kΩ        | 1.3V             | R <sub>1DIV</sub> = 2kΩ, R <sub>2DIV</sub> = open |
| 1.500kΩ        | 1.275V           | R <sub>1DIV</sub> = 2kΩ, R <sub>2DIV</sub> = open |
| 1.780kΩ        | 1.25V            | R <sub>1DIV</sub> = 2kΩ, R <sub>2DIV</sub> = open |
| 2.100kΩ        | 1.225V           | R <sub>1DIV</sub> = 2kΩ, R <sub>2DIV</sub> = open |
| 2.430kΩ        | 1.2V             | R <sub>1DIV</sub> = 2kΩ, R <sub>2DIV</sub> = open |
| 2.800kΩ        | 1.175V           | R <sub>1DIV</sub> = 2kΩ, R <sub>2DIV</sub> = open |
| 3.240kΩ        | 1.15V            | R <sub>1DIV</sub> = 2kΩ, R <sub>2DIV</sub> = open |
| 3.740kΩ        | 1.12V            | R <sub>1DIV</sub> = 2kΩ, R <sub>2DIV</sub> = open |
| 4.220kΩ        | 1.1V             | R <sub>1DIV</sub> = 2kΩ, R <sub>2DIV</sub> = open |
| 4.750kΩ        | 1.075V           | R <sub>1DIV</sub> = 2kΩ, R <sub>2DIV</sub> = open |
| 5.360kΩ        | 1.05V            | R <sub>1DIV</sub> = 2kΩ, R <sub>2DIV</sub> = open |
| 6.040kΩ        | 1.03V            | R <sub>1DIV</sub> = 2kΩ, R <sub>2DIV</sub> = open |
| 6.810kΩ        | 1.0V             | R <sub>1DIV</sub> = 2kΩ, R <sub>2DIV</sub> = open |
| 7.680kΩ        | 0.975V           | R <sub>1DIV</sub> = 2kΩ, R <sub>2DIV</sub> = open |
| 8.660kΩ        | 0.95V            | R <sub>1DIV</sub> = 2kΩ, R <sub>2DIV</sub> = open |
| 9.530kΩ        | 0.925V           | R <sub>1DIV</sub> = 2kΩ, R <sub>2DIV</sub> = open |
| 10.500kΩ       | 0.9V             | R <sub>1DIV</sub> = 2kΩ, R <sub>2DIV</sub> = open |
| 11.800kΩ       | 0.875V           | R <sub>1DIV</sub> = 2kΩ, R <sub>2DIV</sub> = open |
| 13.000kΩ       | 0.85V            | R <sub>1DIV</sub> = 2kΩ, R <sub>2DIV</sub> = open |
| 14.300kΩ       | 0.825V           | R <sub>1DIV</sub> = 2kΩ, R <sub>2DIV</sub> = open |
| 15.800kΩ       | 0.8V             | R <sub>1DIV</sub> = 2kΩ, R <sub>2DIV</sub> = open |
| 17.400kΩ       | 0.775V           | R <sub>1DIV</sub> = 2kΩ, R <sub>2DIV</sub> = open |
| 19.100kΩ       | 0.75V            | R <sub>1DIV</sub> = 2kΩ, R <sub>2DIV</sub> = open |
| 21.000kΩ       | 0.725V           | R <sub>1DIV</sub> = 2kΩ, R <sub>2DIV</sub> = open |
| 23.200kΩ       | 0.7V             | R <sub>1DIV</sub> = 2kΩ, R <sub>2DIV</sub> = open |

**Table 9: Supported Configuration Voltage Values For EM2130H Output Voltage**

| RVSET Resistor | V <sub>OUT</sub> | External Resistor Divider                        |
|----------------|------------------|--|
| 0kΩ            | Reserved         | R <sub>1DIV</sub> = 2kΩ, R <sub>2DIV</sub> = 1kΩ |

| RVSET Resistor | V <sub>OUT</sub> | External Resistor Divider                        |
|----------------|------------------|--|
| 0.392kΩ        | Reserved         | R <sub>1DIV</sub> = 2kΩ, R <sub>2DIV</sub> = 1kΩ |
| 0.576kΩ        | 3.3V             | R <sub>1DIV</sub> = 2kΩ, R <sub>2DIV</sub> = 1kΩ |
| 0.787kΩ        | 3.2V             | R <sub>1DIV</sub> = 2kΩ, R <sub>2DIV</sub> = 1kΩ |
| 1.000kΩ        | 3.1V             | R <sub>1DIV</sub> = 2kΩ, R <sub>2DIV</sub> = 1kΩ |
| 1.240kΩ        | 3.0V             | R <sub>1DIV</sub> = 2kΩ, R <sub>2DIV</sub> = 1kΩ |
| 1.500kΩ        | 2.9V             | R <sub>1DIV</sub> = 2kΩ, R <sub>2DIV</sub> = 1kΩ |
| 1.780kΩ        | 2.8V             | R <sub>1DIV</sub> = 2kΩ, R <sub>2DIV</sub> = 1kΩ |
| 2.100kΩ        | 2.7V             | R <sub>1DIV</sub> = 2kΩ, R <sub>2DIV</sub> = 1kΩ |
| 2.430kΩ        | 2.6V             | R <sub>1DIV</sub> = 2kΩ, R <sub>2DIV</sub> = 2kΩ |
| 2.800kΩ        | 2.5V             | R <sub>1DIV</sub> = 2kΩ, R <sub>2DIV</sub> = 2kΩ |
| 3.240kΩ        | 2.4V             | R <sub>1DIV</sub> = 2kΩ, R <sub>2DIV</sub> = 2kΩ |
| 3.740kΩ        | 2.3V             | R <sub>1DIV</sub> = 2kΩ, R <sub>2DIV</sub> = 2kΩ |
| 4.220kΩ        | 2.2V             | R <sub>1DIV</sub> = 2kΩ, R <sub>2DIV</sub> = 2kΩ |
| 4.750kΩ        | 2.1V             | R <sub>1DIV</sub> = 2kΩ, R <sub>2DIV</sub> = 2kΩ |
| 5.360kΩ        | 2.0V             | R <sub>1DIV</sub> = 2kΩ, R <sub>2DIV</sub> = 2kΩ |
| 6.040kΩ        | 1.9V             | R <sub>1DIV</sub> = 2kΩ, R <sub>2DIV</sub> = 2kΩ |
| 6.810kΩ        | 1.8V             | R <sub>1DIV</sub> = 2kΩ, R <sub>2DIV</sub> = 2kΩ |
| 7.680kΩ        | 1.75V            | R <sub>1DIV</sub> = 2kΩ, R <sub>2DIV</sub> = 2kΩ |
| 8.660kΩ        | 1.7V             | R <sub>1DIV</sub> = 2kΩ, R <sub>2DIV</sub> = 2kΩ |
| 9.530kΩ        | 1.65V            | R <sub>1DIV</sub> = 2kΩ, R <sub>2DIV</sub> = 2kΩ |
| 10.500kΩ       | 1.6V             | R <sub>1DIV</sub> = 2kΩ, R <sub>2DIV</sub> = 2kΩ |
| 11.800kΩ       | 1.55V            | R <sub>1DIV</sub> = 2kΩ, R <sub>2DIV</sub> = 2kΩ |
| 13.000kΩ       | 1.5V             | R <sub>1DIV</sub> = 2kΩ, R <sub>2DIV</sub> = 2kΩ |
| 14.300kΩ       | 1.475V           | R <sub>1DIV</sub> = 2kΩ, R <sub>2DIV</sub> = 2kΩ |
| 15.800kΩ       | 1.45V            | R <sub>1DIV</sub> = 2kΩ, R <sub>2DIV</sub> = 2kΩ |
| 17.400kΩ       | 1.425V           | R <sub>1DIV</sub> = 2kΩ, R <sub>2DIV</sub> = 2kΩ |
| 19.100kΩ       | 1.4V             | R <sub>1DIV</sub> = 2kΩ, R <sub>2DIV</sub> = 2kΩ |
| 21.000kΩ       | 1.375V           | R <sub>1DIV</sub> = 2kΩ, R <sub>2DIV</sub> = 2kΩ |
| 23.200kΩ       | 1.35V            | R <sub>1DIV</sub> = 2kΩ, R <sub>2DIV</sub> = 2kΩ |

## ENABLE And OUTPUT START-UP BEHAVIOR

The control pin (CTRL) provides a means to enable normal operation or to shut down the device. When the CTRL pin asserted (high) the device will undergo a normal soft-start. A logic low on this pin will power the device down in a controlled manner. Dedicated pre-biased start-up logic ensures proper start-up of the power converter when the output capacitors are pre-charged to a non-zero output voltage. Closed-loop stability is ensured during this period.

The typical power sequencing, including ramp up/down and delays is shown in [Figure 6](#).

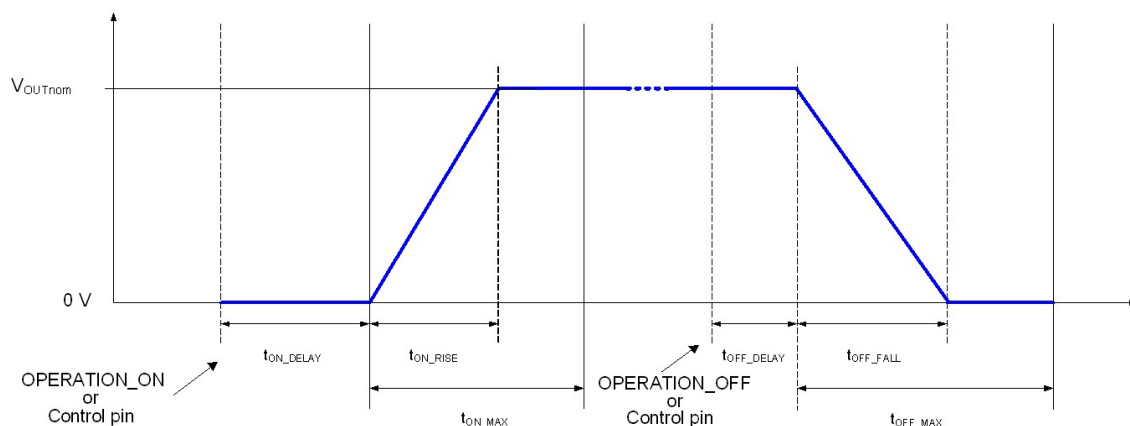

Figure 6: Power Sequencing

## POWER OK

The EM2130 has a power good indicator at its output pin, POK. When de-asserted, POK indicates that the output voltage is below the threshold value, 90% of the programmed output voltage in the default configuration. When asserted, POK indicates that the output is in regulation, and no major faults are present. As a result, POK de-asserts during any serious fault condition where power conversion stops and re-asserts when the output voltage recovers.

The POK indication can be either push-pull or open-drain, selected based upon the PMBus™ address. For addresses in the range 0x01 to 0x40, the POK signal is a push-pull output and no pull-up resistor is required. For addresses in the range 0x41 to 0x7F, the POK signal is open-drain and may be wire-OR'd with other open drain signals with an appropriate pull-up resistor. The Pull-Up resistor may be connected to the VDD33 pin but it is not recommended to use the 5VCC supply. [Table 15](#) describes the resistor values which are used to set the PMBus address.

In a noisy application, it is strongly recommended that a 100nf decoupling capacitor be placed between the POK pin and GND to act as a filter to unwanted external noise. When configured as a Push-Pull output, a 10kΩ pull-down resistor to Gnd may be used instead to prevent any spurious noise spikes appearing on POK upon power being applied to the module.

## COMPENSATING THE DIGITAL CONTROL LOOP

To improve the transient performance for a typical point-of-load design, it is common to add output capacitance to the converter. This moves the output LC resonant frequency lower as capacitance increases which results in lower bandwidth, lower phase margin, and longer settling times unless the control loop is compensated for added capacitance.

However, with EM2130 the user does not need to be concerned with, or even understand, the details of control loop compensation techniques. The default configuration allows users to select from preconfigured PID control loop settings (known as compensators) through the use of pin-strapping. A single resistor from the RTUNE pin to AGND informs the EM2130 of the compensator selection.

The selection of the compensator is driven first by the type of output capacitors used, as the ESL and ESR of different capacitor types demands different PID coefficients to optimize transient deviation and recovery characteristics. An all ceramic output capacitor design requires a different compensator than a design with a combination of ceramic and polymer capacitors, i.e. POSCAP. [Table 12](#) shows several output capacitor part number recommendations.

The five different compensators can then be subdivided into groups of six each whereby the initial capacitance value in the appropriate compensator can be scaled upwards by multiplication factor M to match the additional capacitance.

Table 10: RTUNE configuration table for EM2130L

| Compensator Description   | C <sub>OUT</sub> | RTUNE Resistor | Multiplication factor (M) | Typical Deviation With 15A Load Step |
|---|------------------|----------------|---------------------------|--------------------------------------|
| Polymer Aluminum (SP-CAP) and Ceramic MLCC Output Capacitors<br>Base capacitance = 1 x 470µF (Polymer) + 2 x 100µF (Ceramic) + 2 x 47µF (Ceramic) | Base             | 0kΩ            | 1                         | ± 5%                                 |
|   | 2 x Base         | 0.392kΩ        | 2                         | ± 3%                                 |
|   | 3 x Base         | 0.576kΩ        | 3                         |                                      |
|   | 4 x Base         | 0.787kΩ        | 4                         | ± 1.5%                               |
|   | 5 x Base         | 1.000kΩ        | 5                         |                                      |
|   | 6 x Base         | 1.240kΩ        | 6                         |                                      |
| All MLCC Ceramic Output Capacitors<br>Base capacitance = 8 x 100µF  | Base             | 1.500kΩ        | 1                         | ± 5%                                 |
|   | 1.5 x Base       | 1.780kΩ        | 1.5                       |                                      |
|   | 2 x Base         | 2.100kΩ        | 2                         | ± 3%                                 |
|   | 3 x Base         | 2.430kΩ        | 3                         |                                      |
|   | 4 x Base         | 2.800kΩ        | 4                         |                                      |
|   | 4.5 x Base       | 3.240kΩ        | 4.5                       | ± 1.5%                               |
| POSCAP and Ceramic MLCC Output Capacitors<br>Base capacitance = 4 x 330 µF (POSCAP) + 2 x 100 µF (Ceramic)  | Base             | 3.740kΩ        | 1                         | ± 5%                                 |
|   | 1.5 x Base       | 4.220kΩ        | 1.5                       |                                      |
|   | 2 x Base         | 4.750kΩ        | 2                         | ± 3%                                 |
|   | 2.5 x Base       | 5.360kΩ        | 2.5                       |                                      |
|   | 3 x Base         | 6.040kΩ        | 3                         | ± 1.5%                               |
|   | 3.5 x Base       | 6.810kΩ        | 3.5                       |                                      |
| Reserved for User Programmed Compensation Values  |                  | 7.680kΩ        |                           |                                      |
|   |                  | 8.660kΩ        |                           |                                      |
|   |                  | 9.530kΩ        |                           |                                      |
|   |                  | 10.500kΩ       |                           |                                      |
|   |                  | 11.800kΩ       |                           |                                      |
|   |                  | 13.000kΩ       |                           |                                      |
|   |                  | 14.300kΩ       |                           |                                      |
|   |                  | 15.800kΩ       |                           |                                      |
|   |                  | 17.400kΩ       |                           |                                      |
|   |                  | 19.100kΩ       |                           |                                      |
|   |                  | 21.000 kΩ      |                           |                                      |
|   | 23.200 kΩ        |                |                           |                                      |

**Table 11: RTUNE configuration table for EM2130H**

| Compensator Description   | C <sub>OUT</sub> | RTUNE Resistor | Multiplication factor (M) | Typical Deviation With 15A Load Step |
|---|------------------|----------------|---------------------------|--------------------------------------|
| Polymer Aluminum (SP-CAP) and Ceramic MLCC Output Capacitors<br>Base capacitance = 2 x 220µF (Polymer) + 6 x 47µF (Ceramic) | Base             | 0kΩ            | 1                         | ± 3%                                 |
|   | 2 x Base         | 0.392kΩ        | 2                         |                                      |
|   | 2.5 x Base       | 0.576kΩ        | 2.5                       |                                      |
|   | 3 x Base         | 0.787kΩ        | 3                         |                                      |
|   | 3.5 x Base       | 1.000kΩ        | 3.5                       |                                      |
|   | 4 x Base         | 1.240kΩ        | 4                         |                                      |
| All MLCC Ceramic Output Capacitors<br>Base capacitance = 10 x 100µF   | Base             | 1.500kΩ        | 1                         | ± 3%                                 |
|   | 1.5 x Base       | 1.780kΩ        | 1.5                       |                                      |
|   | 2 x Base         | 2.100kΩ        | 2                         |                                      |
|   | 2.5 x Base       | 2.430kΩ        | 2.5                       |                                      |
|   | 2.75 x Base      | 2.800kΩ        | 2.75                      |                                      |
|   | 3 x Base         | 3.240kΩ        | 3                         |                                      |
| Reserved for User Programmed Compensation Values  |                  | 3.740kΩ        |                           |                                      |
|   |                  | 4.220kΩ        |                           |                                      |
|   |                  | 4.750kΩ        |                           |                                      |
|   |                  | 5.360kΩ        |                           |                                      |
|   |                  | 6.040kΩ        |                           |                                      |
|   |                  | 6.810kΩ        |                           |                                      |
|   |                  | 7.680kΩ        |                           |                                      |
|   |                  | 8.660kΩ        |                           |                                      |
|   |                  | 9.530kΩ        |                           |                                      |
|   |                  | 10.500kΩ       |                           |                                      |
|   |                  | 11.800kΩ       |                           |                                      |
|   |                  | 13.000kΩ       |                           |                                      |
|   |                  | 14.300kΩ       |                           |                                      |
|   |                  | 15.800kΩ       |                           |                                      |
|   |                  | 17.400kΩ       |                           |                                      |
|   | 19.100kΩ         |                |                           |                                      |
|   | 21.000 kΩ        |                |                           |                                      |
|   | 23.200 kΩ        |                |                           |                                      |

**Table 12: Recommended Output Capacitors**

| Description                                | Manufacturer | P/N                |
|--|--------------|--------------------|
| 470 $\mu$ F, 2.5V, ESR 3m $\Omega$ SP-CAP  | Panasonic    | EEFGX0E471R        |
| 330 $\mu$ F, 6.3V, ESR 9 m $\Omega$ POSCAP | Panasonic    | 6TPF330M9L         |
| 220 $\mu$ F, 6.3V, ESR 5 m $\Omega$ POSCAP | Panasonic    | 6TPF220M5L         |
| 330 $\mu$ F, 2.5V, ESR 9 m $\Omega$ POSCAP | Kemet        | T520B337M2R5ATE009 |
| 100 $\mu$ F, 6.3V, X5R, 1206 Ceramic       | Kemet        | C1206C107M9PACTU   |
| 47 $\mu$ F, 6.3V, X5R 12b06 Ceramic        | Murata       | GRM31CR60J476ME19L |

## OUTPUT CAPACITOR RECOMMENDATION

EM2130 is designed for fast transient response and low output ripple noise. The output capacitors should be low ESR polymer, tantalum or ceramic capacitor. [Table 10](#) and [Table 11](#) show different output capacitor combinations to optimize the load transient deviation performance. With the Rtune feature, the user can simply scale up the total output capacitance to meet further stringent transient requirement.

Please consult the documentation for your particular FPGA, ASIC, processor, or memory block for the transient and the bulk decoupling capacitor requirements.

## INPUT CAPACITOR RECOMMENDATION

The EM2130 input should be decoupled with at least three 22 $\mu$ F 1206 case size and one 10 $\mu$ F 0805 case size MLCC ceramic capacitors or four 22 $\mu$ F MLCC 1206 case size ceramic capacitors. More bulk capacitor may be needed only if there are long inductive traces at the input source or there is not enough source capacitance.

These input decoupling ceramic capacitors can be mounted on the PCB back-side to reduce the solution size. These input filter capacitors should have the appropriate voltage rating for the input voltage on PVIN, and use a X5R, X7R, or equivalent dielectric rating. Y5V or equivalent dielectric formulations must not be used as these lose too much capacitance with frequency, temperature and bias voltage.

The PVCC pin provides power to the gate drive of the internal high/low side power MOSFETs. The VCC pin provides power to the internal digital controller. These two power inputs share the same supply voltage (5V nominal), and should be bypassed with a single 2.2 $\mu$ F MLCC capacitor. To avoid switching noise injection from PVCC to VCC, it is recommended a ferrite bead is inserted between PVCC and VCC pins as shown [Figure 15](#).

## PROTECTION FEATURES

The EM2130 offers a complete suite of programmable fault warnings and protections. Input and output Under Voltage Lock-Out (UVLO) and Over Voltage Lock-Out (OVLO) conditions are continuously monitored. A dedicated ADC is used to provide fast and accurate current information during the entire switching period to provide fast Over-Current Protection (OCP) response.

To prevent damage to the load, the EM2130 utilizes an output over-voltage protection circuit. The voltage at VSEN is continuously compared with a configurable threshold using a high-speed analog comparator. If the voltage exceeds the configured threshold, a fault response is generated and the PWM output is turned off.

The output voltage is also sampled, filtered, and compared with an output over-voltage warning threshold. If the output voltage exceeds this threshold, a warning is generated and the preconfigured actions are

triggered. The EM2130 also monitors the output voltage with two lower thresholds. If the output voltage is below the under-voltage warning level and above the under-voltage fault level, an output voltage under-voltage warning is triggered. If the output voltage falls below the fault level, a fault event is generated.

Similar to output over and under voltage protection, the EM2130 monitors the input voltage at VINSEN continuously with a configurable threshold. If the input voltage exceeds the over voltage threshold or is below the under voltage threshold, the default response is generated.

Over Temperature Protection (OTP) is based on direct monitoring of the device's internal temperature. If the temperature exceeds the OTP threshold, the device will enter a soft-stop mode slowly ramping the output voltage down until the temperature falls below the default recovery temperature.

The default fault response is zero delay and latch off for most fault conditions. The CTRL pin may be cycled to clear the latch. Table 13 summarizes the default configurations that have been pre-programmed to the device.

**Table 13: Fault Configuration Overview**

| Signal                    | Fault Level | Default Response Type | Delay (ms) | Retries  |
|---------------------------|-------------|-----------------------|------------|----------|
| Output Over-Voltage       | Warning     |                       | 0          | None     |
|                           | Fault       | High-impedance        |            |          |
| Output Under-Voltage      | Warning     |                       | 0          | None     |
|                           | Fault       | High-impedance        |            |          |
| Input Over-Voltage        | Warning     |                       | 0          | None     |
|                           | Fault       | High-impedance        |            |          |
| Input Under-Voltage       | Warning     |                       | 0          | Infinity |
|                           | Fault       | High-impedance        |            |          |
| Over-Current              | Warning     |                       | 0          | None     |
|                           | Fault       | High-impedance        |            |          |
| Internal Over-Temperature | Warning     |                       | 0          | Infinity |
|                           | Fault       | Soft Off              |            |          |

## FUNCTIONAL DESCRIPTION: ADVANCED CONFIGURATION

All EM2130 modules are delivered with a pre-programmed default configuration, allowing the module to be powered up without a need to configure the device or even the need for the GUI to be connected. However, a PMBus version 1.2 compliant interface allows access to an extensive suite of digital communication and control commands. This includes configuring the EM2130 for optimum performance, setting various parameters such as output voltage, and monitoring and reporting device behavior including output voltage, output current, and fault responses.

The device may be reconfigured multiple times without storing the configuration into the non-volatile memory (NVM). Any configuration changes will be lost upon power-on reset unless specifically stored into NVM using either STORE\_DEFAULT\_ALL or STORE\_DEFAULT\_CODE PMBus commands. Please see [Table 16](#) for more details.

For RVSET and RTUNE configurations, there is no reprogramming permitted.

After writing a new configuration to NVM, the user may still make changes to the device configuration through the PMBus interface; however, now upon power cycling the device, the stored NVM configuration will be recalled upon power-up rather than the factory default configuration of the EM2130.



The NVM configuration can be stored three times in its entirety. However, the consumption of the available NVM is dynamic, based on the configuration parameters that have actually changed. The unused NVM information is given in the GUI or through the manufacture specific command MFR\_STORE\_PARAMS\_REMAINING.

## INTEL DIGITAL POWER CONFIGURATOR

The Intel Enpirion Digital Power Configurator is a Graphical User Interface (GUI) software which allows the EM2130 to be controlled via a USB interface to a host computer.

The user can view the power supply's status, I/O voltages, output current and fault conditions detected by the device, program settings to the converter, and issue PMBus commands using the GUI. Most of the parameters (for example, VOUT turn on/off time, protection and fault limits) can be configured and adjusted within the GUI environment. These parameters can also be configured outside of the GUI environment using the relevant PMBus™ commands.

The GUI also allows the user to easily create, modify, test and save a configuration file which may then be used to permanently burn the configuration into NVM within a production test environment.

## ALTERNATIVE OUTPUT VOLTAGE CONTROL METHODS

In the default configuration, output voltage selection is determined at power-up by the pin-strapped resistor RVSET. This functionality can be disabled using the PMBus command MFR\_PIN\_CONFIG. When RVSET is disabled, the output voltage will be determined by the nominal output voltage setting in the user configuration. The EM2130 supports a subset of the output voltage commands outlined in the PMBus specification. For example, the output voltage can be dynamically changed using the PMBus command VOUT\_COMMAND. When the output is being changed by the PMBus command, power good (POK) remains at a logic high.

## POWER SEQUENCING AND THE CONTROL (CTRL) PIN

Three different configuration options are supported to enable the output voltage. The device can be configured to turn on after an OPERATION\_ON command, via the assertion of the CTRL pin or a combination of both per the PMBus convention. The EM2130 supports power sequencing features including programmable ramp up/down and delays. The typical sequence of events is shown in [Figure 6](#) and follows the PMBus standard. The individual timing values shown in [Figure 6](#) and [Figure 7](#) can be configured using the appropriate configuration setting in Intel Digital Power Configurator GUI.

## PRE-BIASED START-UP AND SOFT-STOP

In systems with complex power architectures, there may be leakage paths from one supply domain, which charge capacitors in another supply domain leading to a pre-biased condition on one or more power supplies. This condition is not ideal and can be avoided through careful design, but is generally not harmful. Attempting to discharge the pre-bias is not advised as it may force high current through the leakage path. The EM2130 includes features to enable and disable into pre-biased output capacitors.

If the output capacitors are pre-biased when the EM2130 is enabled, start-up logic in the EM2130 ensures that the output does not pull down the pre-biased voltage and the  $t_{ON\_RISE}$  timing is preserved. Closed-loop stability is ensured during the entire start-up sequence under all pre-bias conditions.

The EM2130 also supports pre-biased off, in which the output voltage ramp down to a user-defined level ( $V_{OFF\_nom}$ ) rather than to zero. After receiving the disable command, via PMBus command or the CTRL pin, the EM2130 ramps down the output voltage to the predefined value. Once the value is reached, the output driver goes into a tristate mode to avoid excessive currents through the leakage path.

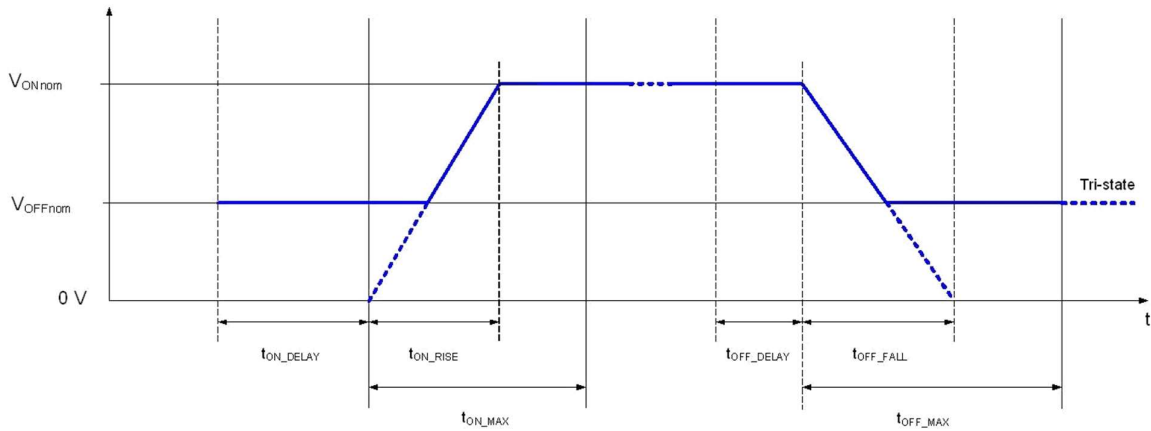

Figure 7: Power Sequencing With Non-Zero Off Voltage

### VOLTAGE TRACKING

The EM2130 can control the output voltage based on the external voltage applied to the VTRACK pin, thus allowing sequencing of the output voltage from an external source. Pre-bias situations are also supported. The VTRACK pin voltage is a single-ended input referenced to analog ground. Tracking mode is disabled by default, but it can be enabled using the GUI software or via the manufacturer-specific PMBus command, MFR\_FEATURES\_CTRL (see Table 16).

If VTRACK is not intended to be used, tie the VTRACK pin low or leave it floating.

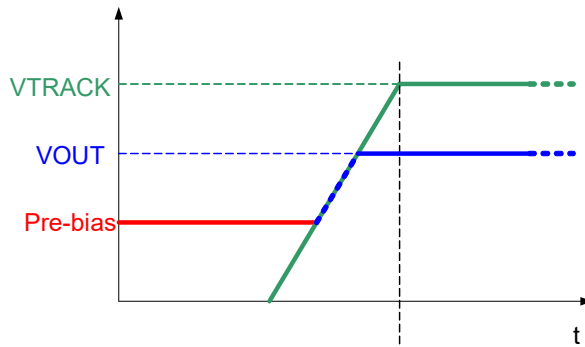

Figure 8: Power Sequencing Using VTRACK With Bias Voltage On VOUT

The set point voltage for the EM2130 is defined by the lower value of the  $V_{OUT}$  setting or an external voltage applied to the VTRACK pin. If the VTRACK voltage rises above the  $V_{OUT}$  set point voltage, then the final output voltage will be limited by the  $V_{OUT}$  setting. If the tracking feature is enabled, but the VTRACK pin is tied low or floating, then the output will never start as the VTRACK pin input is always the lower value and will always be in control. Conversely, if tracking is enabled, but VTRACK is tied high, the output will start but will follow the  $V_{OUT}$  set point, not the VTRACK pin.

If tracking is used for sequencing, it is recommended that the VTRACK signal be kept greater than the  $V_{OUT}$  voltage. This ensures that the internal  $V_{OUT}$  set point is used as the final steady-state output voltage and accuracy is not a function of the externally applied VTRACK voltage. The tracking function will override a programmed pre-bias off level ( $V_{OFF\_nom}$ ).