



Chipsmall Limited consists of a professional team with an average of over 10 year of expertise in the distribution of electronic components. Based in Hongkong, we have already established firm and mutual-benefit business relationships with customers from,Europe,America and south Asia,supplying obsolete and hard-to-find components to meet their specific needs.

With the principle of “Quality Parts,Customers Priority,Honest Operation,and Considerate Service”,our business mainly focus on the distribution of electronic components. Line cards we deal with include Microchip,ALPS,ROHM,Xilinx,Pulse,ON,Everlight and Freescale. Main products comprise IC,Modules,Potentiometer,IC Socket,Relay,Connector.Our parts cover such applications as commercial,industrial, and automotives areas.

We are looking forward to setting up business relationship with you and hope to provide you with the best service and solution. Let us make a better world for our industry!



Contact us

Tel: +86-755-8981 8866 Fax: +86-755-8427 6832

Email & Skype: info@chipsmall.com Web: www.chipsmall.com

Address: A1208, Overseas Decoration Building, #122 Zhenhua RD., Futian, Shenzhen, China



Description

This is the EN6310QI User Guide. The EN6310QI features an integrated inductor, power MOSFETS, a controller, a bulk of the compensation network, and protection circuitry against system faults. This level of integration delivers a substantial reduction in footprint and

parts count over competing solutions. The evaluation board is optimized for engineering ease of testing through programming options, clip leads, test points and other supporting external components.

Evaluation Board Over View

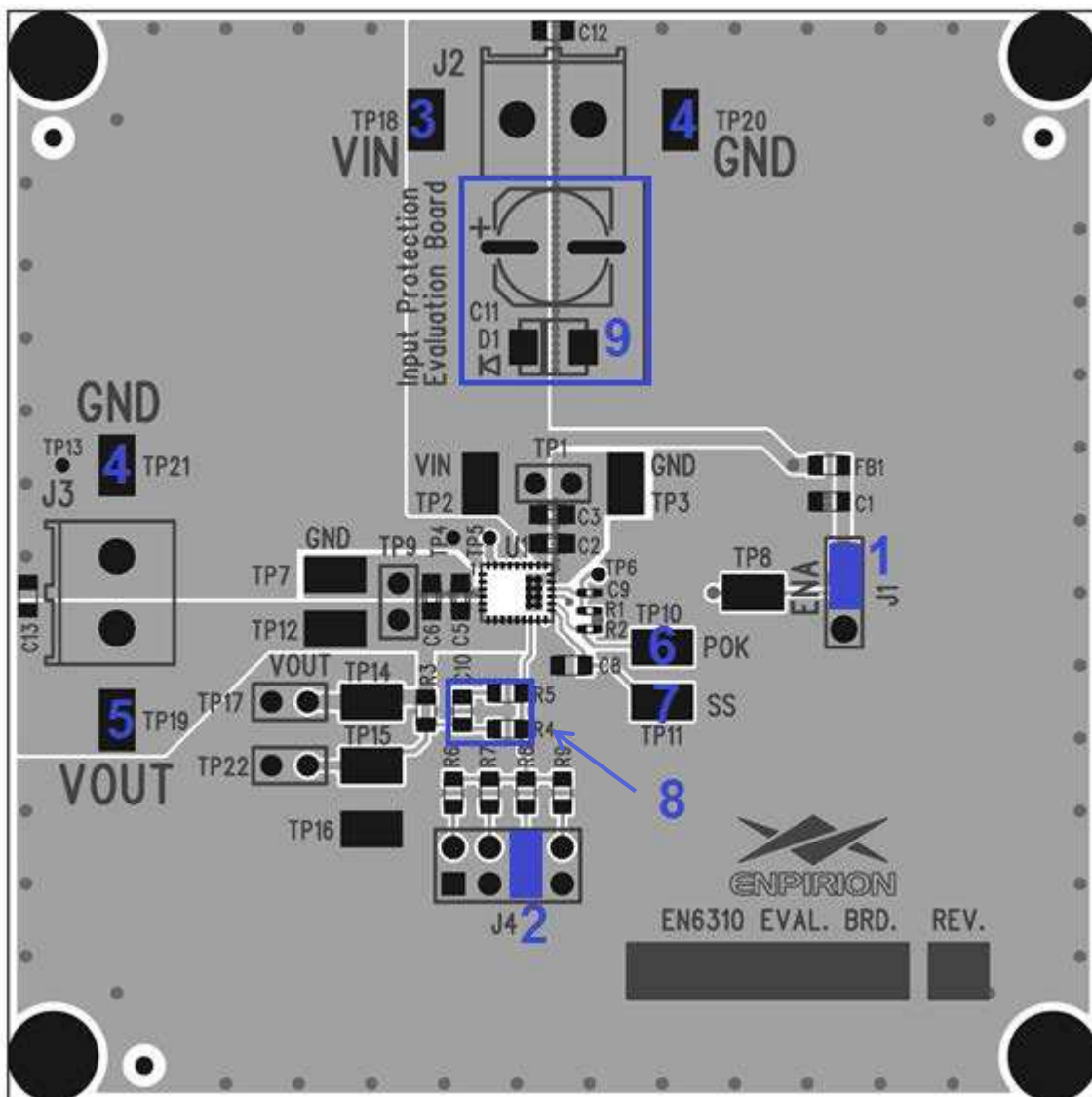

Figure 1. EN6310QI Evaluation Board Illustration

Instructions

The numbers in the instructions below correspond to the numbers in Figure 1. By following the number sequence below, the device can be turned on by step 5.

- 1) **ENABLE (J1)** – Connecting a jumper to the upper two pins of J1 enables the device. Connecting a jumper on the lower two pins of J1 disables the device. Leave J1 open and use an external signal on TP8 to toggle the enable on (>1.8V) and off (<0.4V).
- 2) **Output Voltage Settings (J4)** – With a jumper placed as shown, output voltage is set to 1.2V. The jumper may be switched to change the output voltage from left to right (3.3V, 1.8V, 1.2V and 1.0V). The output voltage may also be adjusted by changing R_B (R_4) as shown in Figure 2.

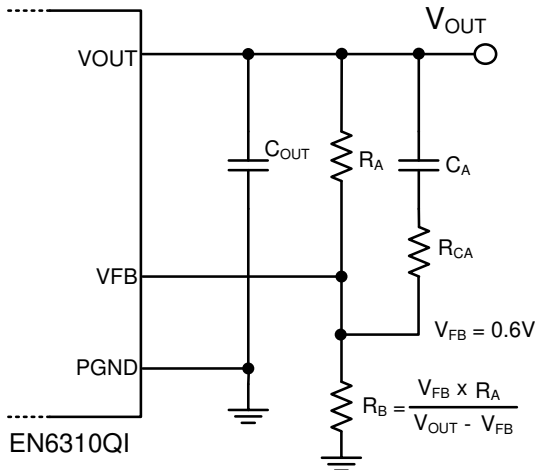

Figure 2. External Compensation

- 3) **VIN (TP18)** – Connect the positive terminal of a 2.7V to 5.5V power supply to TP18. Do not turn the power supply on until everything is connected correctly.
- 4) **Ground (TP20 and TP21)** – Connect the power supply’s negative terminal ground to TP20 and the load ground to TP21.
- 5) **VOUT (TP19)** – Connect the load to TP19. If the instructions were followed up to this point, the power supply may be turned on. If output voltage is not present after turning on the power supply, check the position of the jumper on J1.

- 6) **POK (TP10)** – This is the open drain POK flag, which is pulled up to V_{IN} by R_1 when V_{OUT} is over 90% of regulation.
- 7) **SS (TP11)** – The soft start capacitor is by defaulted 10nF and can be between 0.47nF to 10nF. See Datasheet for details.
- 8) **External Compensation ($R_4 = R_a$), $C_{10} = C_a$, $R_5 = R_{ca}$)** – The on board values are designed to work with a variety of input and output voltage ranges. For optimization, follow the table below:

CIN = 4.7µF/0603 + 100pF						
CAVIN = 20Ω + 0.47µF						
COUT = 47µF/0805 or 2x22µF/0603						
RA = 200kΩ, Rca = 1kΩ, RB = 0.6RA/(VOUT - 0.6)						
VIN (V)	VOUT (V)	Ca (pF)	VIN (V)	VOUT (V)	Ca (pF)	
5.5	3.3	15	5.5	1.2	27	
5		15	5		27	
4.5		15	4.5		33	
5.5	2.5	15	3.3		1	33
5		15	2.7			39
4.5		15	5.5			39
3.3	1.8	15	5	0.6		39
5.5		15	4.5			39
5		15	3.3			47
4.5	1.5	15	2.7		0.6	47
3.3		22	5.5			39
2.7		22	5			39
5.5	1.5	22	4.5	0.6		47
5		22	3.3			56
4.5		22	2.7			56
3.3	1.5	27	0.6		0.6	33
2.7		33				

- 9) **Input Protection** – The EN6310QI evaluation board comes with some input polarity protection. Be sure to follow input voltage specifications based on the Datasheet.

Evaluation Board Schematic

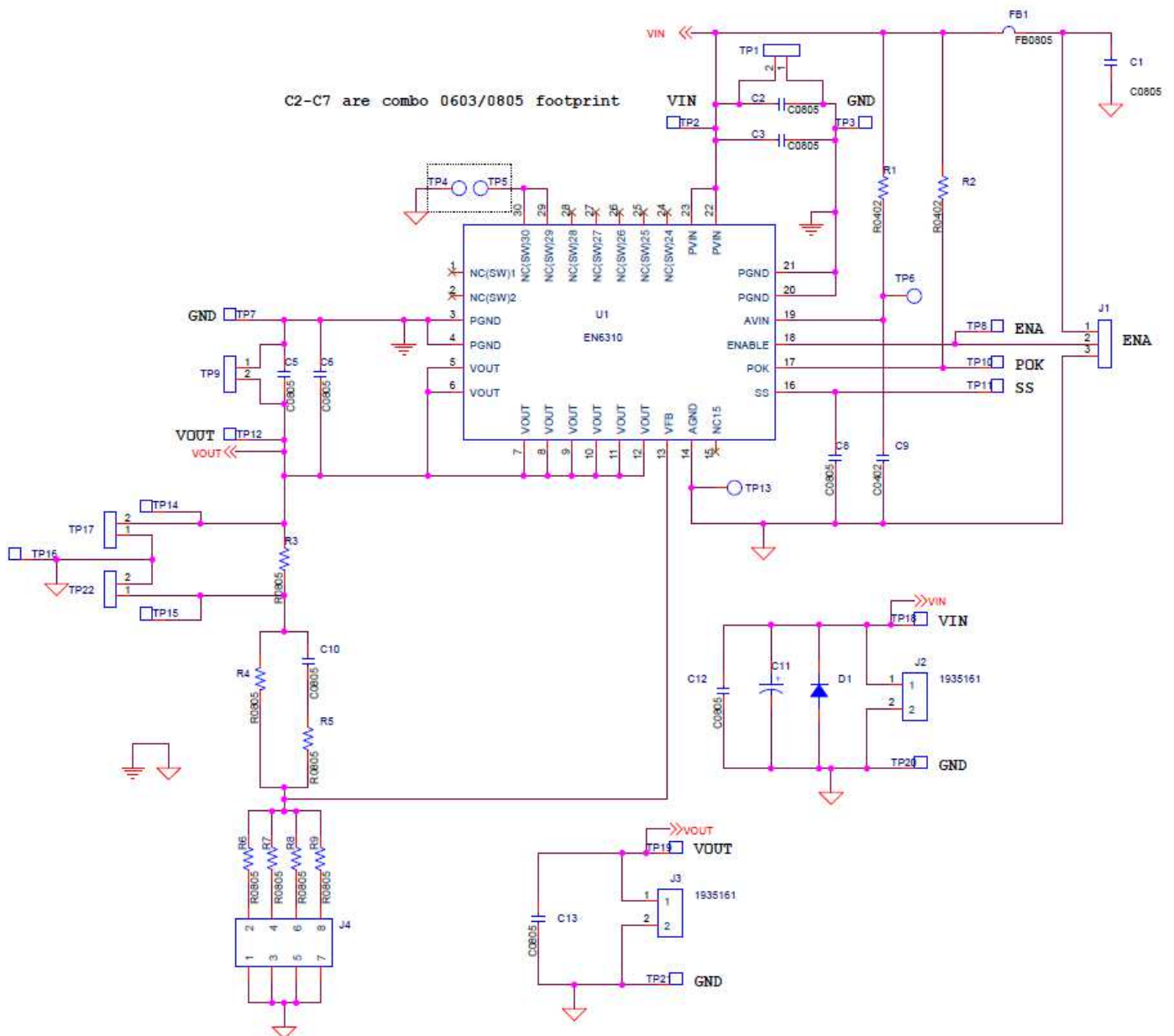

Bill of Materials

Designator	Qty	Description
R1	1	RES 10.0 OHM 1/16W 1% 0402 SMD
R2	1	RES 100K OHM 1/16W 1% 0402 SMD
R4, R8	2	RES 200K OHM 1/8W 0.1% 0805 SMD
R5	1	1K 1% 0805 CHIP RESISTOR 1/8W
R6	1	RES 44.2K OHM 1/8W 1% 0805 SMD
R7	1	RES 100K OHM 1/8W 0.1% 0805 SMD
R9	1	RES 301K OHM 1/8W 0.1% 0805 SMD
TP2,TP3,TP7,TP8, TP10-TP12,TP14- TP16,TP18-TP21	14	TEST POINT SURFACE MOUNT
C10	1	CAP CER 15PF 50V 5% NPO 0402
C1	1	CAP, 10UF 0805 X7R 10% 10V CERAMIC
C2	1	CAP,4.7UF, 0603, 10V, 10%, X5R
C5	1	CAP CER 47UF 6.3V X5R 0805
C8	1	CAP CER 10000PF 50V 10% X7R 0805
C9	1	CAPACITOR CER 0.10UF 50V X7R 0402
C11	1	CAP 47UF 16V ELECT FC SMD
D1	1	S2A DIODE
FB1	1	MULTILAYER SMD FERRITE BEAD 4000MA 0805 L=TYPICAL (NOT GUARANTEED)
J1	1	TERM BLOCK PCB 2POS 5.0MM GREEN
J2, J3	2	CONNECTOR HEADER 8 POS .100" STR TIN
C3,C6,C12,C13,R3	5	COMPONENT NOT USED ** DO NOT INSTALL **
U1	1	GOLD EN6310QI POL USING 6310-01 DIE 5X4 34L

Test Recommendations

To guarantee measurement accuracy, the following precautions should be observed:

- 1.
2. Make all input and output voltage measurements at the board using the test points provided (TP1 to TP9). This will eliminate voltage drop across the line and load cables that can produce false readings.
3. Measure input and output current with series ammeters or accurate shunt resistors. This is especially important when measuring efficiency.
4. Use a low-loop-inductance scope probe tip similar to the one shown below to measure switching signals and input / output ripple to avoid noise coupling into the probe ground lead. Input ripple, output ripple, and load transient deviation are best measured near the respective input / output capacitors. For more accurate ripple measurement, please see Enpirion App Note regarding this subject.

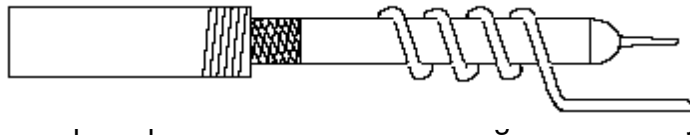

5. The board includes status at clip lead marked POK.
6. The board includes an enable pin, which turns the device on when pulled high. When EN is low, the IC goes into shutdown mode. In “always-on” applications, EN can be tied to VIN.

Contact Information

Altera Corporation
 101 Innovation Drive
 San Jose, CA 95134
 Phone: 408-544-7000
www.altera.com

© 2013 Altera Corporation—Confidential. All rights reserved. ALTERA, ARRIA, CYCLONE, ENPIRION, HARDCOPY, MAX, MEGACORE, NIOS, QUARTUS and STRATIX words and logos are trademarks of Altera Corporation and registered in the U.S. Patent and Trademark Office and in other countries. All other words and logos identified as trademarks or service marks are the property of their respective holders as described at www.altera.com/common/legal.html. Altera warrants performance of its semiconductor products to current specifications in accordance with Altera's standard warranty, but reserves the right to make changes to any products and services at any time without notice. Altera assumes no responsibility or liability arising out of the application or use of any information, product, or service described herein except as expressly agreed to in writing by Altera. Altera customers are advised to obtain the latest version of device specifications before relying on any published information and before placing orders for products or services.