



Chipsmall Limited consists of a professional team with an average of over 10 year of expertise in the distribution of electronic components. Based in Hongkong, we have already established firm and mutual-benefit business relationships with customers from,Europe,America and south Asia,supplying obsolete and hard-to-find components to meet their specific needs.

With the principle of “Quality Parts,Customers Priority,Honest Operation,and Considerate Service”,our business mainly focus on the distribution of electronic components. Line cards we deal with include Microchip,ALPS,ROHM,Xilinx,Pulse,ON,Everlight and Freescale. Main products comprise IC,Modules,Potentiometer,IC Socket,Relay,Connector.Our parts cover such applications as commercial,industrial, and automotives areas.

We are looking forward to setting up business relationship with you and hope to provide you with the best service and solution. Let us make a better world for our industry!



Contact us

Tel: +86-755-8981 8866 Fax: +86-755-8427 6832

Email & Skype: info@chipsmall.com Web: www.chipsmall.com

Address: A1208, Overseas Decoration Building, #122 Zhenhua RD., Futian, Shenzhen, China



Enpirion EN63A0QI 12A DC/DC Converter w/Integrated Inductor Evaluation Board

Introduction

Thank you for choosing Altera® Enpirion power products!

This user guide should be used together with the latest device datasheet.

- The EN63A0QI features integrated inductor, power MOSFETS, controller, bulk of the compensation network, and protection circuitry against system faults. This level of integration delivers a substantial reduction in footprint and part count over competing solutions. This evaluation board is optimized for ease of use through programming options, clip leads, test points, etc.
- The EN63A0QI features a customer programmable output voltage by means of a resistor divider. The resistor divider allows the user to set the output voltage to any value within the range 0.6V to $(V_{IN} - V_{DROPOUT})$. The Dropout voltage is $\sim 0.05 \cdot I_{LOAD}$ (see Figure 1). The evaluation board, as shipped is populated with a single R_A , and three possible R_B resistors. The R_B resistors can be chosen by jumper settings to achieve several output voltages.
- The EN63A0QI includes the bulk of the compensation network internally. However, an external phase-lead (zero) capacitor and resistor is required as part of the feedback. This network is shown in Figure 1. Appropriate component values allow for optimum compensation for a given Input voltage and choice of loop bandwidth. The equations in Figure 1 provide the details to calculate the component values.
- A footprint is provided for a SMC connector (not populated) for S_{IN} . A clock source may be applied to S_{IN} to synchronize the device switching frequency to the external source. Please see the datasheet for the frequency lock frequency range. S_{OUT} will output a clock signal synchronous with the switching frequency. S_{OUT} of one EN63A0QI may be connected to S_{IN} of another EN63A0QI device.
- Jumpers are provided for logical programming of the following signals:
 - ENABLE (ENA)
 - Master/Slave ternary input (M/S)
 - Enable Pre-Bias Input (SEL)Enable may also be controlled using an external switching source by removing the jumper and applying the enable signal to the connector middle pin and ground.
 - Jumpers are also provided for getting various output voltages.
- The board comes with input decoupling and reverse polarity protection to guard the device against common setup mishaps.

- The board also has soldermask openings for 0805 ceramic capacitors at the input and output edges. If you are planning to do radiated any EMI testing on this board, place a 10uF, 0805, X7R or X5R capacitor at each board edge. The added capacitor at the input edge is for high-frequency decoupling of the input cables. The added capacitor at the output edge is meant to represent a typical load decoupling capacitor.

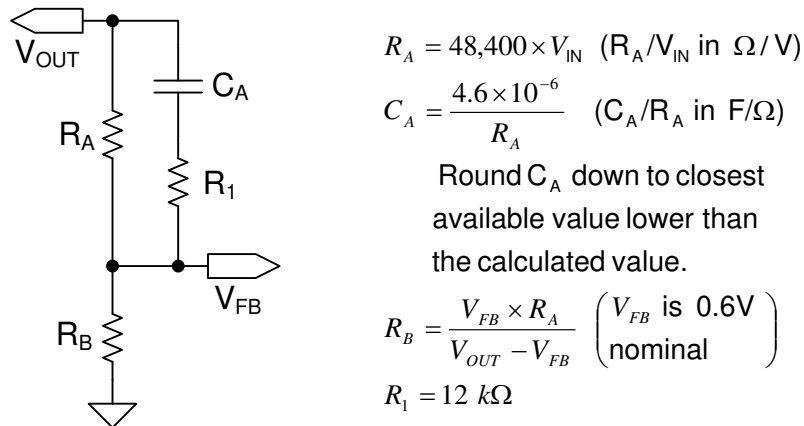

Figure 1: Output voltage programming and loop compensation.

Quick Start Guide

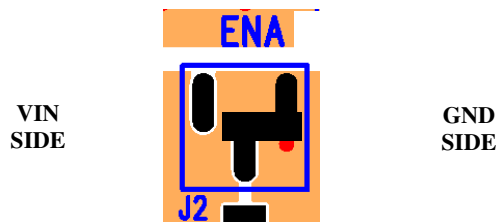

Figure 2: J2 allows control of the Enable pin.

The jumper on Enable pin as shown is in disable mode. When jumper is between the middle and right pins the signal pin is connected to ground or logic low. When the jumper is between the left and middle pins, the signal pin is connected to VIN or logic High.

WARNING: complete steps 1 through 4 before applying power to the EN63A0QI evaluation board.

STEP 1: Set the “ENA” jumper to the Disable Position.

STEP 2: Set the output voltage by putting a jumper in the desired positions for connector header J5 as shown below. In order for this board to work,

you always need a jumper in the leftmost position of J5 as shown in Figure 3. If all other jumper positions are left open, then R_B will be open, and V_{OUT} will be 0.6V nominal. The other positions will select the three possible R_B resistors. Table 1 shows the R_A and all possible R_B values, and the resulting V_{OUT} for each combination of R_A and single R_B . Please see Figures 1 and 5. It is possible to use parallel combinations of the three R_B resistors to get other output voltages. Please note the R_A , C_A , and R_B values for this board have been optimized for an input voltage of around 6V using the equations in Figure 1. The part will be stable for lower V_{IN} values, but to get optimum transient response, new R_A , C_A , and R_B values have to be calculated and installed.



Figure 3: Shows the voltage selection jumpers

The leftmost position has to always have a jumper in it. Nominal output voltages, from left to right, for second through fourth positions are 1.80V, 1.20V, and 1.02V. Jumpers as shown, select 1.20V output.

CAUTION: Except ENA, no other jumpers can be changed while the EN63A0QI is enabled. Doing so could result in damage to the part. Always disable part when changing output voltage setting.

Reference Designator	Nominal Value	Nominal V_{OUT}
R3 (R_A in Figure 1)	301k Ω	0.6V with no R_B
R8 (R_B in Figure 1)	150k Ω	1.80V
R7 (R_B in Figure 1)	301k Ω	1.20V
R6 (R_B in Figure 1)	430k Ω	1.02V

Table 1 – V_{OUT} resistor divider values and the resulting output voltages if only a single R_B is used. You could use more than one R_B and get other output voltages. Use the third equation in Figure 1, and solve for V_{OUT} .

STEP 3: Assuming parallel operation is not needed, leave the M/S jumper not populated (floating).

STEP 4: The SEL jumper controls the EN_PB pin. If left floating, this pin is pulled high internally, and the device will support monotonic startup under pre-biased load. To pull this pin low, put the jumper between the middle and right pins just as shown in Figure 2 for the ENABLE pin.

STEP 5: Connect Power Supply to the input power connectors, VIN (J7) and GND (J11) as indicated in Figure 4 and set the power supply to the desired voltage ($\leq 6.6V$.)

CAUTION: Be mindful of the polarity. Even though the evaluation board comes with reverse polarity protection diodes, it may not protect the device under all conditions.

STEP 6: Connect the load to the output connectors VOUT (J6) and GND (J10), as indicated in Figure 4.

STEP 7: Power up the board and move the ENA jumper to the enabled position. The EN63A0QI is now powered up and generating the desired output. You are free to make Efficiency, Ripple, Line/Load Regulation, Load transient, Power OK, over current limit and temperature related measurements.

STEP 7A: Power Up/Down Behavior – Remove ENA jumper and connect a pulse generator (output disabled) signal to the middle pin of ENA and Ground. Set the pulse amplitude to swing from 0 to 2.5 volts. Set the pulse period to 10msec., duty cycle to 50% and fast transition ($< 1\mu\text{sec.}$) Hook up oscilloscope probes to ENA, POK and V_{OUT} with clean ground returns. Enable pulse generator output. Observe the V_{OUT} voltage ramps as ENA goes high and again as ENA goes low.

STEP 8: Phase Lock – Disable device by moving ENA jumper. Power down the device. Connect a pulse generator (properly terminated and output disabled) signal between S_IN and GND, preferably using an SMC connector. Set the pulse amplitude to swing from 0 to 2.5 volts. Set the pulse frequency to the converter's free running frequency. Connect oscilloscope probes to S_IN and S_OUT. Power up device. Enable device. Note S_OUT – it is the free running switching frequency. Now enable the pulse generator output. S_OUT should be locked to S_IN with a fixed delay. Sweep the clock frequency within the External Sync Clock Frequency Lock Range as specified in the datasheet, and note the lock range at both extremes.

ALWAYS power down device before changing board level components!

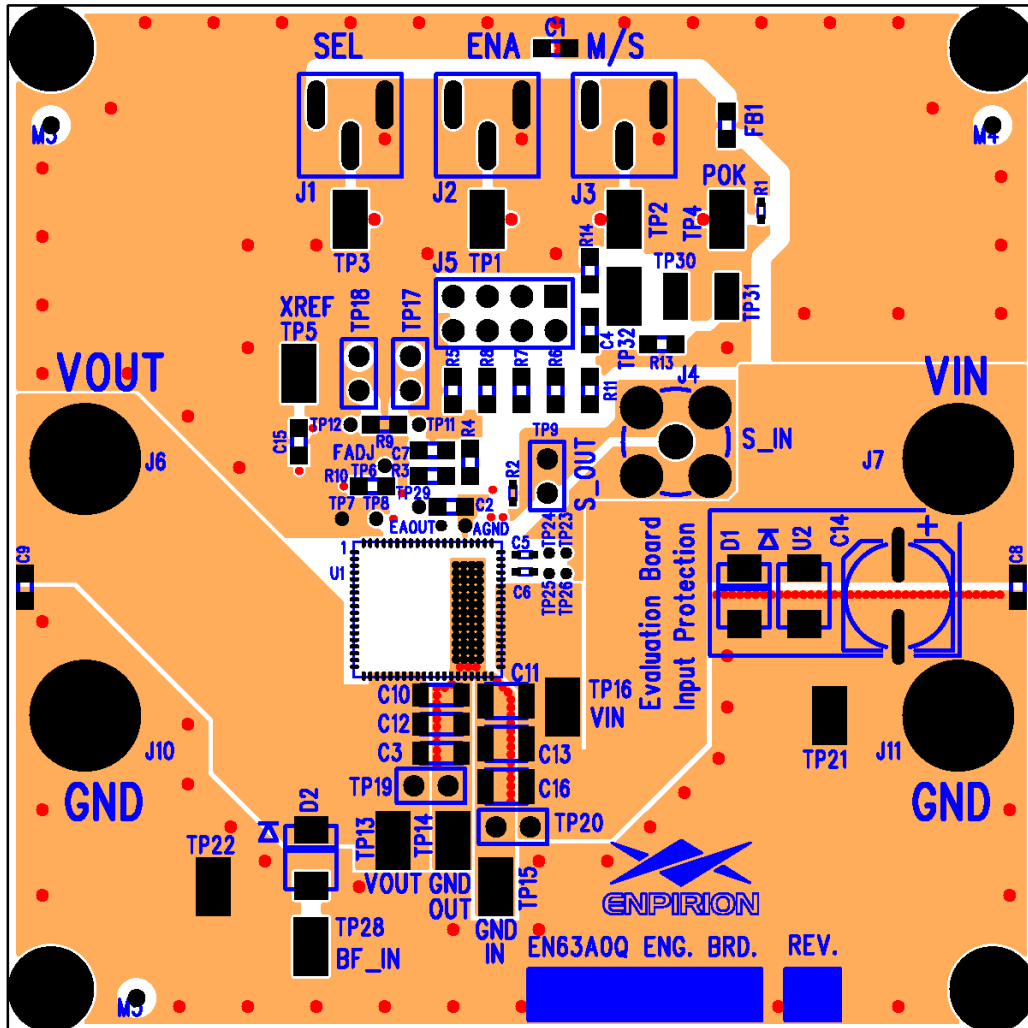

Figure 4: Evaluation Board Layout Assembly Layer.

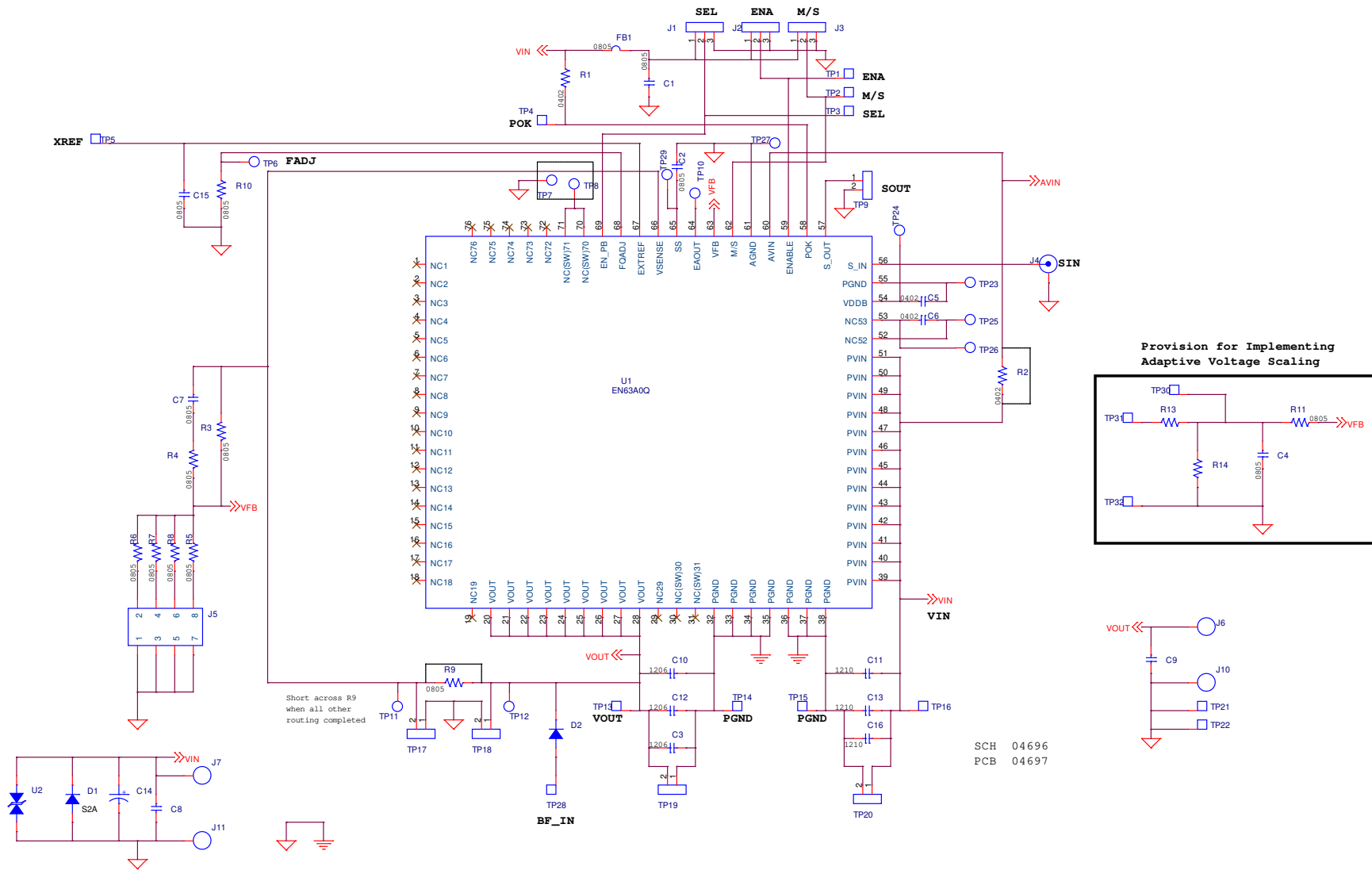
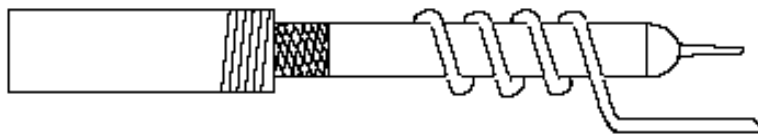

Figure 5: Evaluation Board Schematic

Test Recommendations

To guarantee measurement accuracy, the following precautions should be observed:

1. Make all input and output voltage measurements at the board using the surface-mount test points provided. This will eliminate voltage drop across the line and load cables that can produce false readings.
2. Measure input and output current with series ammeters or accurate shunt resistors. This is especially important when measuring efficiency.
3. Use a low-loop-inductance probe tip shown below to measure V_{OUT} and switching signals to avoid noise coupling into the probe ground lead. Output ripple and load transient deviations are conveniently measured at TP19. For more accurate ripple measurement, please refer to Enpirion App Note regarding this subject.



4. The board includes a pull-up for the POK signal and ready to monitor the power OK status.
5. A soft-start capacitor is populated on the board to provide a reasonable soft-start time. It can be changed as needed.
6. The over-current protection circuit typically limits the maximum load current to approximately 14.5A.

Input and Output Capacitors

Please refer to the BOM section for the value of input caps and output caps used on this evaluation board, which is the result of combination for better performance and smaller footprints.

NOTE: Capacitors must be X5R or X7R dielectric formulations to ensure adequate capacitance over operating voltage and temperature ranges.

Bill of Materials

Designator	Qty	Description
C1	1	CAP, 10uF 0805 X7R 10% 10V CERAMIC
C2	1	CAP, 15000pF 10% 50V SMD 0805 X7R CERAMIC
C3, C10-C13	5	CAP, CER 47UF 10V X5R 1206
C5	1	CAPACITOR CER .10UF 25V X5R 0402
C7	1	CAP, 15pF 50V CERM CHIP 0805 SMD
C14	1	CAP, SMT ELECTROLYTIC, 150uF, 20%, 10V
C4, C6, C8, C9, C15, C16, J4, R2, R9, R11, R13, R14, TP30-TP32	15	NOT USED
D1, D2	2	S2A DIODE
FB1	1	MULTILAYER SMD FERRITE BEAD 4000MA 0805 L=TYPICAL (NOT GUARANTEED)
J1, J3	2	CONN, VERTICAL, 3 POSITION, SMT
J5	1	CONNECTOR HEADER 8 POS .100" STR TIN
J6, J7, J10, J11	4	BANANA JACK
R1	1	RES 100K OHM 1/16W 1% 0402 SMD
R3, R7	2	RES 301K OHM 1/8W 0.1% 0805 SMD
R4	1	RES 12.1K OHM 1/8W 1% 0805 SMD
R5	1	RES 64.9K OHM 1/8W 0.1% 0805 SMD
R6	1	RES 430K OHM 1/8W 0.1% 0805 SMD
R8	1	RES 150K OHM 1/8W 0.1% 0805 SMD
R10	1	RES 4.42K OHM 1/8W 1% 0805 SMD
TP1-TP5, TP13-TP16, TP21, TP22	11	TEST POINT SURFACE MOUNT
U1	1	EN63A0QI QFN 12A
U2	1	TRANSIENT VOLTAGE SUPPRESSOR, 6.5V, BIDIRECTIONAL, SMT

Contact Information

Altera Corporation
101 Innovation Drive
San Jose, CA 95134
Phone: 408-544-7000
www.altera.com

© 2013 Altera Corporation—Confidential. All rights reserved. ALTERA, ARRIA, CYCLONE, ENPIRION, HARDCOPY, MAX, MEGACORE, NIOS, QUARTUS and STRATIX words and logos are trademarks of Altera Corporation and registered in the U.S. Patent and Trademark Office and in other countries. All other words and logos identified as trademarks or service marks are the property of their respective holders as described at www.altera.com/common/legal.html. Altera warrants performance of its semiconductor products to current specifications in accordance with Altera's standard warranty, but reserves the right to make changes to any products and services at any time without notice. Altera assumes no responsibility or liability arising out of the application or use of any information, product, or service described herein except as expressly agreed to in writing by Altera. Altera customers are advised to obtain the latest version of device specifications before relying on any published information and before placing orders for products or services.