



Chipsmall Limited consists of a professional team with an average of over 10 year of expertise in the distribution of electronic components. Based in Hongkong, we have already established firm and mutual-benefit business relationships with customers from,Europe,America and south Asia,supplying obsolete and hard-to-find components to meet their specific needs.

With the principle of “Quality Parts,Customers Priority,Honest Operation,and Considerate Service”,our business mainly focus on the distribution of electronic components. Line cards we deal with include Microchip,ALPS,ROHM,Xilinx,Pulse,ON,Everlight and Freescale. Main products comprise IC,Modules,Potentiometer,IC Socket,Relay,Connector.Our parts cover such applications as commercial,industrial, and automotives areas.

We are looking forward to setting up business relationship with you and hope to provide you with the best service and solution. Let us make a better world for our industry!



## Contact us

Tel: +86-755-8981 8866 Fax: +86-755-8427 6832

Email & Skype: info@chipsmall.com Web: www.chipsmall.com

Address: A1208, Overseas Decoration Building, #122 Zhenhua RD., Futian, Shenzhen, China



# Enpirion EP53F8QI 1.5A Synchronous DCDC Converter Module Evaluation Board

## Introduction

Thank you for choosing Altera Enpirion power products!

You are evaluating a new class of DCDC converter product, a complete power system on silicon:

- The EP53F8QI is a complete module with integrated magnetics.
- The evaluation board is designed to offer a wide range of engineering evaluation capabilities.
- Pads are available to add up to one additional input capacitor and up to one additional output capacitors to allow for evaluation of performance over a wide range of input/output capacitor combinations.
- Output voltage is programmed using a resistor divider. The board comes populated with four pre-placed resistors and a jumper to choose one of four preset output voltages.
- Easy jumpers are provided for the following signals:
  - Enable
  - VOUT
- Numerous test points are provided as well as clip leads for input and output connections
- The board comes with input decoupling and input reverse polarity protection to protect the device from common setup mishaps.

## Quick Start Guide

Figure 1 shows a top view of the evaluation board.

STEP 1: Set the “ENABLE” jumper to the Disable Position.

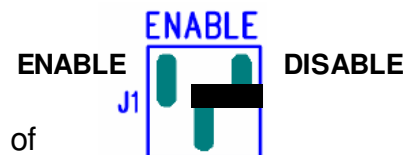

STEP 2: Set the output voltage by setting jumper “J2” to one of the pre selected output voltage settings.

STEP 3: Connect Power Supply to the input power connectors, VIN (+) and GND (-).

**CAUTION:** be mindful of the polarity. Even though the evaluation board comes with reverse polarity protection diodes, it is rarely a good idea to reverse the input polarity.

STEP 4: Connect the load to the output connectors VOUT (+) and GND (-).

STEP 5: Power up the board and move the ENABLE jumper to the enabled position. The EP53F8QI is now powered up.

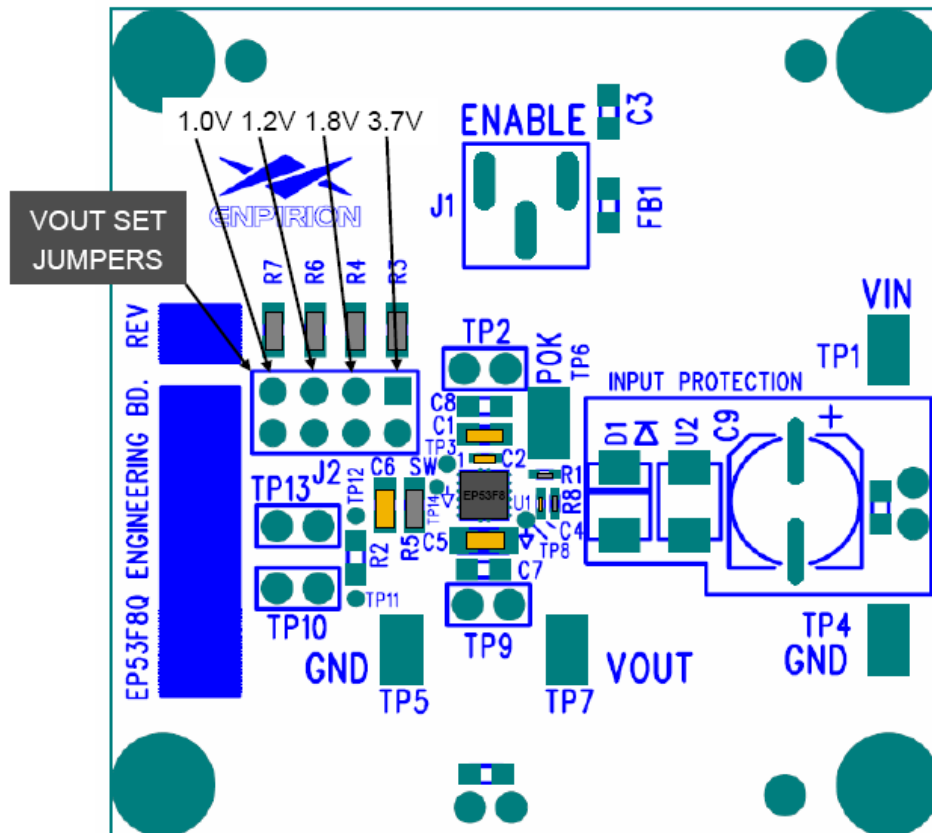

Figure 1. Evaluation Board Layout.

## Output Voltage Select

The output voltage of the EP53F8QI is programmed using a simple resistor divider. The evaluation board comes pre-populated with a set of four jumpers that allow the user to choose one of four preset voltages. Refer to Figure 1 and Figure 2 for the specific settings. If no jumper is populated the default voltage setting will be 0.6V.

It is also possible to remove one of the preset resistors and replace with another value to generate any desired output within the devices operating range.

Refer to the product data sheet for further information on setting the output voltage.

Figure 2 shows a close-up of the jumper on the evaluation board.

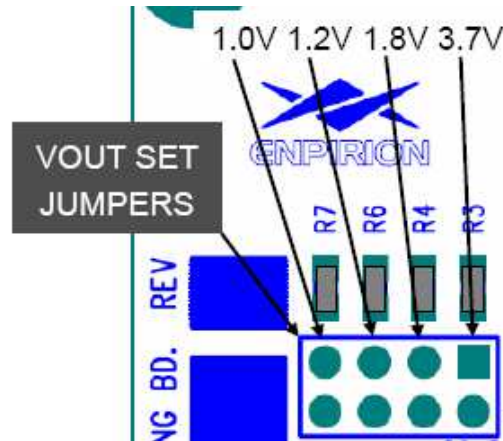
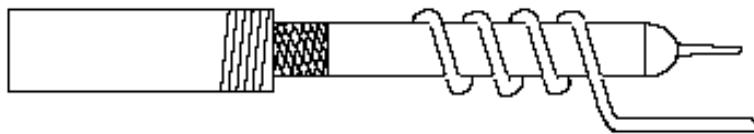

**Figure 2.** Close up of the  $V_{OUT}$  setting jumpers, J2.

## Test Recommendations

To guarantee measurement accuracy, the following precautions should be observed:

1. Make all input and output voltage measurements at the board using the test points provided. This will eliminate voltage drop across the line and load cables that can produce false readings.
2. Measure input and output current with series ammeters or accurate shunt resistors. This is especially important when measuring efficiency.
3. Use a balanced impedance probe tip across  $C_{OUT}$  to measure  $V_{OUT}$  Ripple to avoid noise coupling into the probe ground lead. The recommended probe configuration is shown in Figure 3.



**Figure 3.** Recommended probe configuration.

## Input and Output Capacitors

The **input** capacitance requirement is a 10  $\mu\text{F}$  and a 680pF MLCC capacitor in parallel. The smaller valued capacitor, the 680pF, must be placed closest to the EP53F8QI. Both capacitors have been placed as close to the device as possible to minimize the physical area of the input AC current loop.

There is a pre-tinned pad that allows for an additional 0805 case size MLCC capacitor to experiment with input filter performance.

The **output** capacitance requirement is a minimum of 22 $\mu\text{F}$ . The evaluation board comes populated with a single 22 $\mu\text{F}$  0805 case size MLCC capacitor.

The board has a pre-tinned pad for up to 1 additional 0805 case size output capacitor.

**NOTE:** Capacitors must be X5R or X7R dielectric formulations.

Evaluation Board Metal Layers

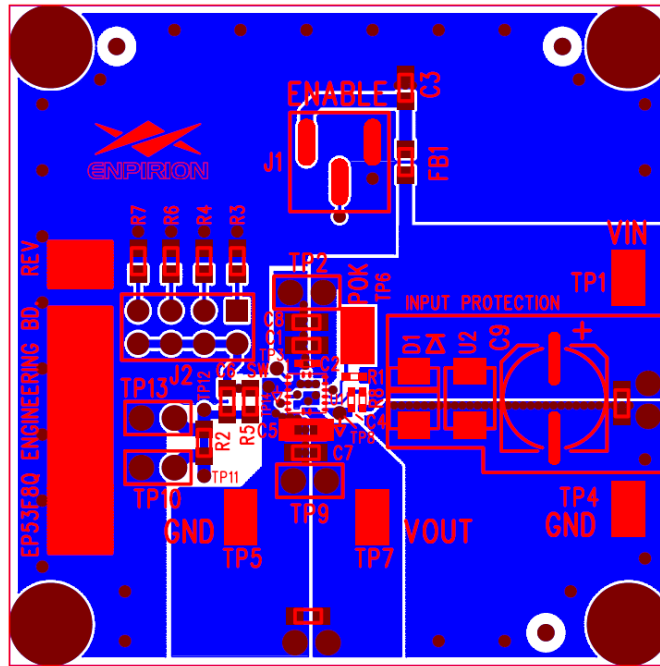

Figure 4. Top layer metal with silkscreen.

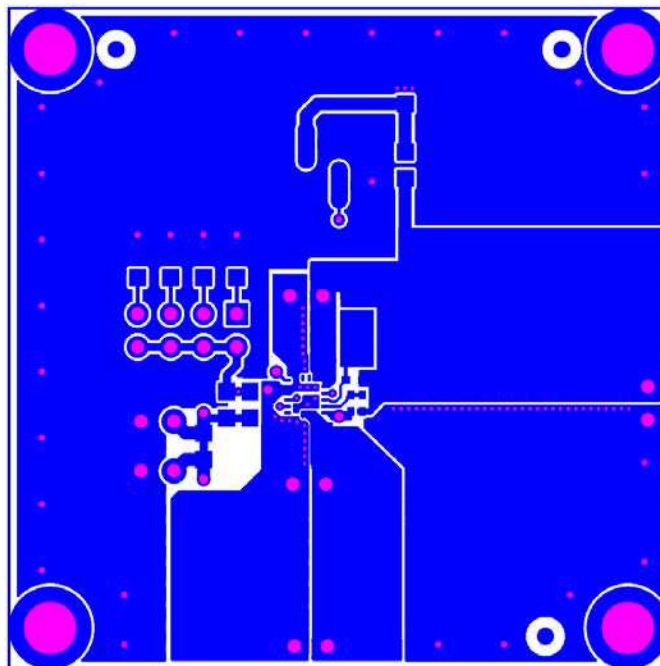
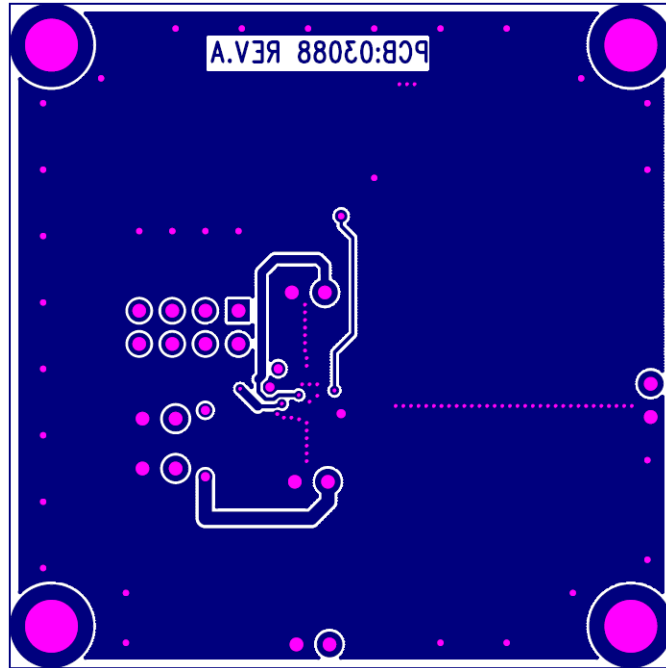
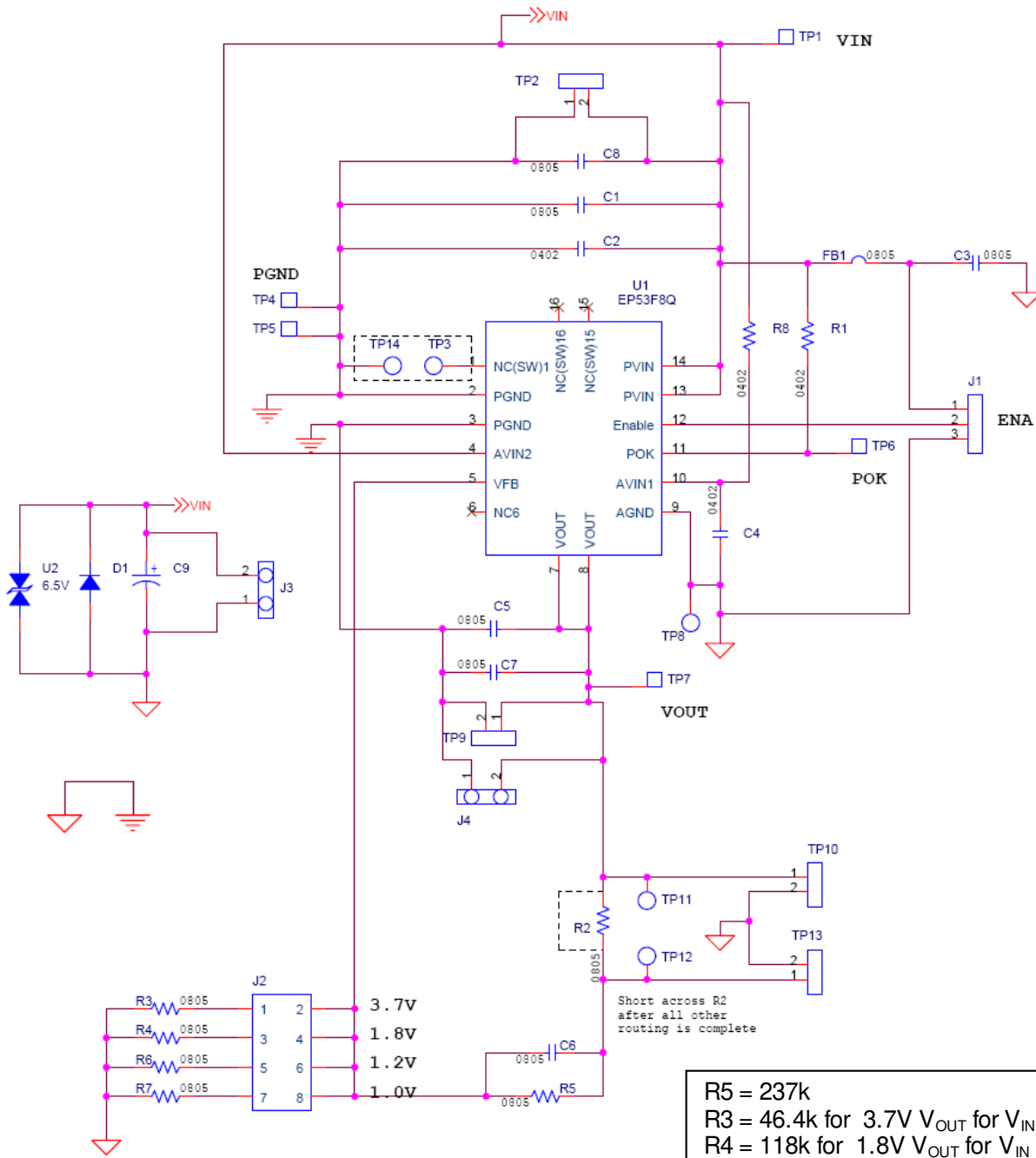

Figure 5. Top layer metal.



**Figure 6.** Bottom layer metal.

Evaluation Board Schematic



R5 = 237k  
 R3 = 46.4k for 3.7V  $V_{OUT}$  for  $V_{IN} = 5V$   
 R4 = 118k for 1.8V  $V_{OUT}$  for  $V_{IN} = 5V$   
 R6 = 237k for 1.2V  $V_{OUT}$  for  $V_{IN} = 5V$   
 R7 = 357k for 1.0V  $V_{OUT}$  for  $V_{IN} = 5V$   
 C6 = 5.0pF  
 C2 = 680pF  
 C1 = 10uF  
 C5 = 22uF





## Contact Information

Altera Corporation  
101 Innovation Drive  
San Jose, CA 95134  
Phone: 408-544-7000  
[www.altera.com](http://www.altera.com)

© 2013 Altera Corporation—Confidential. All rights reserved. ALTERA, ARRIA, CYCLONE, ENPIRION, HARDCOPY, MAX, MEGACORE, NIOS, QUARTUS and STRATIX words and logos are trademarks of Altera Corporation and registered in the U.S. Patent and Trademark Office and in other countries. All other words and logos identified as trademarks or service marks are the property of their respective holders as described at [www.altera.com/common/legal.html](http://www.altera.com/common/legal.html). Altera warrants performance of its semiconductor products to current specifications in accordance with Altera's standard warranty, but reserves the right to make changes to any products and services at any time without notice. Altera assumes no responsibility or liability arising out of the application or use of any information, product, or service described herein except as expressly agreed to in writing by Altera. Altera customers are advised to obtain the latest version of device specifications before relying on any published information and before placing orders for products or services.