



Chipsmall Limited consists of a professional team with an average of over 10 year of expertise in the distribution of electronic components. Based in Hongkong, we have already established firm and mutual-benefit business relationships with customers from,Europe,America and south Asia,supplying obsolete and hard-to-find components to meet their specific needs.

With the principle of “Quality Parts,Customers Priority,Honest Operation,and Considerate Service”,our business mainly focus on the distribution of electronic components. Line cards we deal with include Microchip,ALPS,ROHM,Xilinx,Pulse,ON,Everlight and Freescale. Main products comprise IC,Modules,Potentiometer,IC Socket,Relay,Connector.Our parts cover such applications as commercial,industrial, and automotives areas.

We are looking forward to setting up business relationship with you and hope to provide you with the best service and solution. Let us make a better world for our industry!



Contact us

Tel: +86-755-8981 8866 Fax: +86-755-8427 6832

Email & Skype: info@chipsmall.com Web: www.chipsmall.com

Address: A1208, Overseas Decoration Building, #122 Zhenhua RD., Futian, Shenzhen, China



Description

This is the ER2120QI User Guide. The ER2120QI integrates a controller with integrated power MOSFETs, most of the compensation network, and protection circuitry against system faults. This level of integration delivers

a substantial reduction in footprint and component count compared to competing solutions. The evaluation board is optimized for engineering ease of testing through programming options, clip leads, test points etc.

Evaluation Board Over View

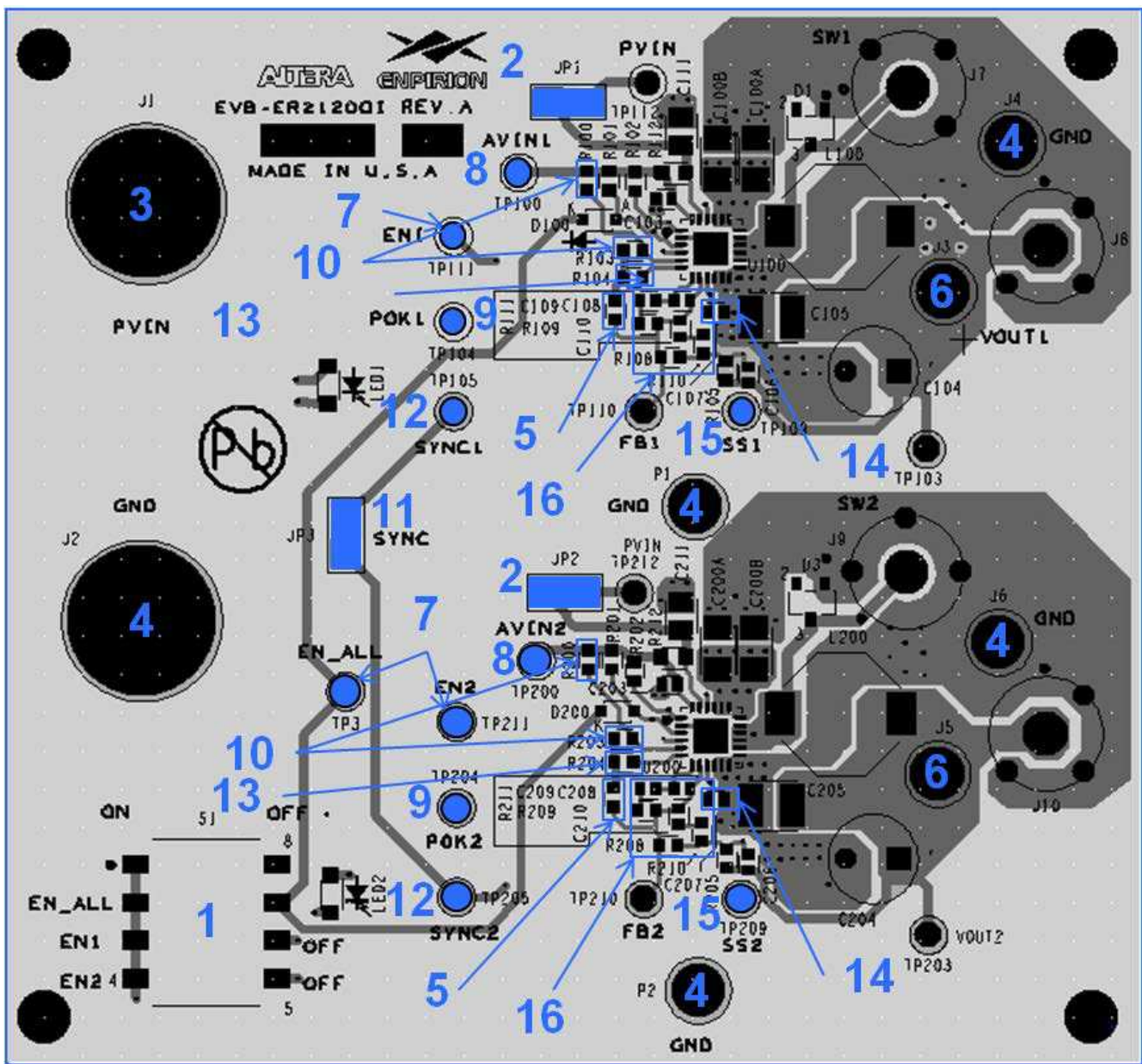

Figure 1. ER2120QI Evaluation Board Illustration (Follow instructions on page 2)

Instructions

The numbers in the instructions below correspond to the numbers in Figure 1. By following the number sequence below, the device can be turned on by step 6.

- 1) **ENABLE (S1, TP3, TP111, and TP211)** –
 - a. (**EN_ALL**) In the ON position, this setting enables both parts provided **EN1** and **EN2** are also in the ON positions. Move the switch to the OFF position to disable both devices.
 - b. (**EN1**) In the ON position, this setting enables the upper device provided the **EN_ALL** switch is also in the ON position.
 - c. (**EN2**) In the ON position, this setting enables the lower device provided the **EN_ALL** switch is also in the ON position.

The functionality of S1 can be overridden by external signals on TP3, TP111, and TP211. Make sure all positions of S1 are in the ON position. Remove R101 & R201 unless the external signal functions as an open-drain.

- 2) **PVIN to AVINO Connections (JP1 and JP2)** – Remove the jumper from JP1 and JP2 for 5.5V to 14V input mode. Install the jumper for 4.5V to 5.5V input mode. Note that both parts are connected to the same supply rail, so both jumpers will typically be connected to the same position.
- 3) **PVIN (J1)** – Connect a 4.5V to 5.5V supply on J1 when VIN is tied to AVINO through JP1 and JP2. If not, Connect a 5.5V to 14V supply on J1. Do not turn on the supply until everything else is connected correctly.
- 4) **Ground (J2, J4, J6, P1, and P2)** – Connect the input ground to J2 and the output ground J4 and J6. P1 and P2 can be used as the GND for the Testing Probes.
- 5) **Output Voltage Settings (R111 and R211)**
The output voltage of the regulator can be programmed via an external resistor divider. Equations 1 and 2 describe the relationship between VOUT and the resistor values.

$$R_{111} = \frac{R_{108} * 0.6V}{V_{out1} - 0.6V} \quad (1)$$

$$R_{211} = \frac{R_{208} * 0.6V}{V_{out2} - 0.6V} \quad (2)$$

Where R108 and R208 are 28kΩ and are the feedback resistor for the upper and the lower parts respectively; 0.6V is the value of the internal reference; and Vout1 and Vout2 are the desired output voltage for the upper and lower parts respectively.

- 6) **VOUT (J3 and J5)** – Connect the load positive terminal to J3 or J5. If the instructions were followed up to this point, the device may be powered on.
- 7) **EN1, EN2 and EN_ALL (TP111, TP211, TP3)** – These are the test pins for the ENABLE pins.
- 8) **AVIN (TP100 and TP200)** – These are the AVIN test points for the upper and lower devices respectively.
- 9) **POK** – This is the open drain POK signal. This pin pulls to low if the output goes out of regulation or a fault is detected. POK is equipped with a fixed delay upon power-on. The POK rising delay from the point where VOUT reaches regulation to the point where POK rises is inversely proportional to the switching frequency.
- 10) **Master/Slave Settings (R100, R103, R200, and R203)** – To configure the upper device as slave, leave R100 open and populate R103 with a 5kΩ resistor. To configure the lower device as slave, leave R200 open and populate R203 with a 5kΩ resistor.

To configure the upper device as master, populate R100 with a 0Ω resistor and leave R103 open. To configure the lower device as master, populate R200 with 0Ω resistor and leave R203 open.

By default, the upper device is configured in master mode and the lower device is configured in slave mode.

- 11) **SYNC (JP3)** – For master-slave operation, JP3 must be installed. To operate the upper and lower devices independently, remove JP3 and configure both devices as master (see Master/Slave Settings).
- 12) **SYNC TP (TP105, TP205)** – These are the SYNC test points for the two parts.
- 13) **Switching Frequency setting (R104 and R204)** – the switching frequency of the regulator can be programmed between 500 kHz and 1.2 MHz, as shown equations 3 and 4.

$$R_{104} = \frac{48000}{f_{osc1} (kHz)} \quad (3)$$

$$R_{204} = \frac{48000}{f_{osc2} (kHz)} \quad (4)$$

Using resistors lower than 40kΩ or higher than 97kΩ may damage the ER2120QI and is not recommended.

- 14) **Soft Start Capacitor (C107 & C207)** – The soft start capacitor is 15nF by default. This capacitor, along with an internal 30μA current source, sets the soft-start interval of the converter, t_{SS} .

$$C_{SS}(\mu F) = 50 * t_{SS} (s) \quad (6)$$

- 15) **Soft Start Capacitor TP (TP109 & TP209)**
These are the soft-start test points.
- 16) **External Compensation** – The on-board values are designed to work with a variety of input and output voltage ranges. For further optimization, follow the datasheet recommendations for compensation design.

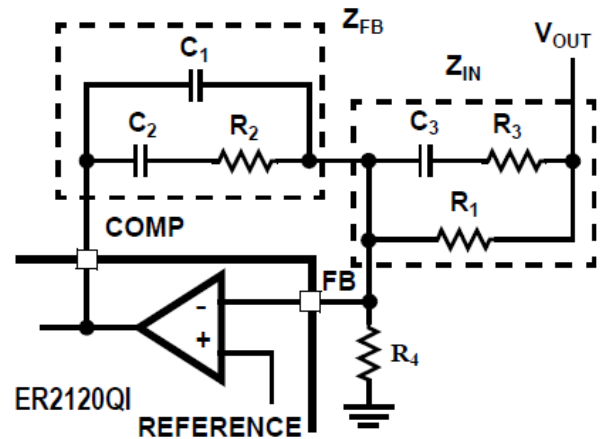
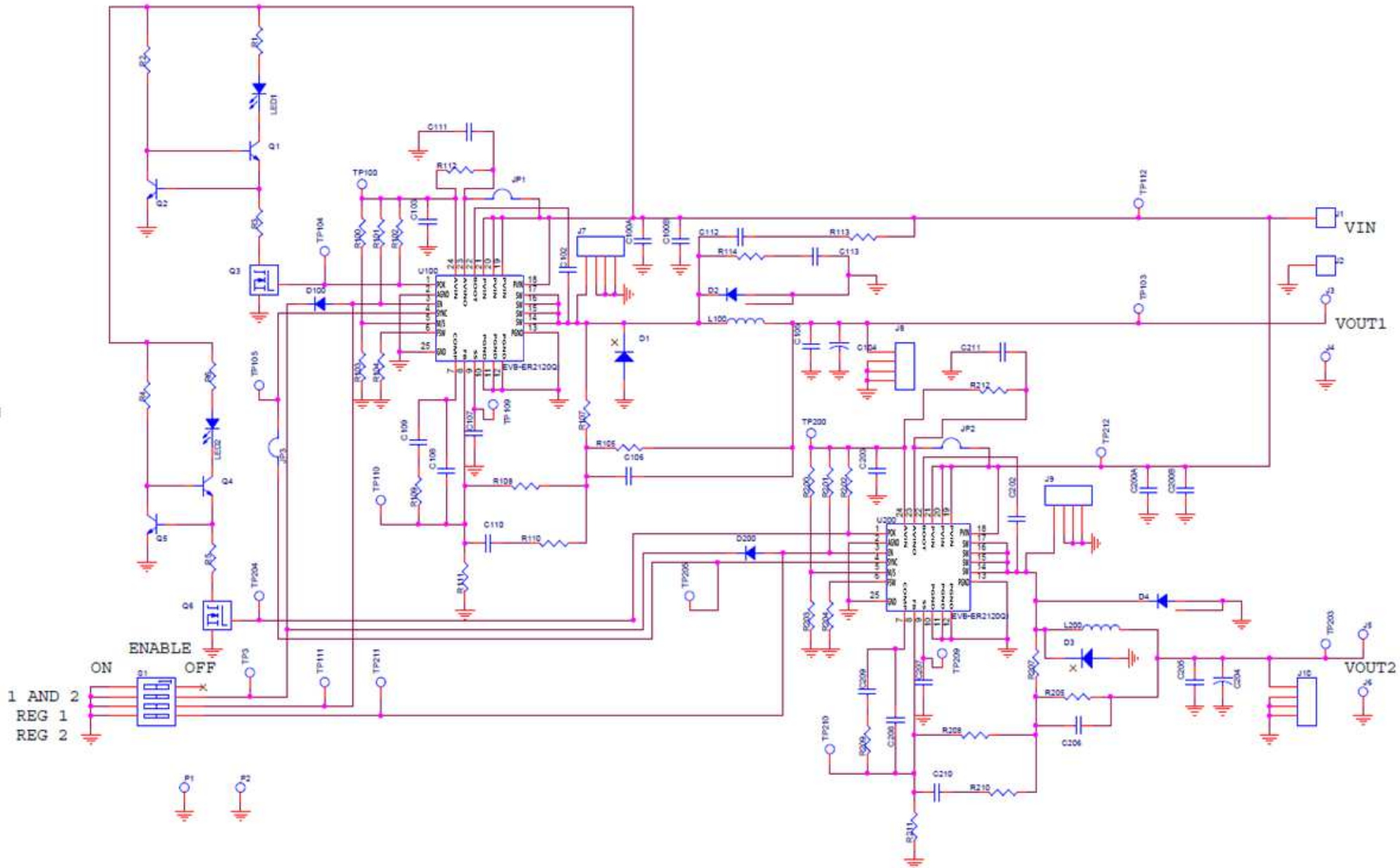

Figure 2. VOLTAGE MODE BUCK CONVERTER COMPENSATION DESIGN

Evaluation Board Schematic



Bill of Materials

Designator	Qty	Description
C100B, C100A, C200B, C200A	4	CAP,SMD,1206,10uF,25V,10%,X5R,ROHS
C102, C202	2	CAP,SMD,0402, 0.1uF,16V,10%,X7R,ROHS
C103, C203	2	CAP,SMD,0402,1.0uF,10V,10%,X5R,ROHS
C104, C204	2	DO NOT POPULATE OR PURCHASE
C105, C205	2	CAP,SMD,1210,100uF,10V,20%,X5R,ROHS
C106, C206	2	CAP,SMD,0402,DNP-PLACE HOLDER,ROHS
C107, C207	2	CAP,SMD,0402,0.015uF,16V,10%,X7R,ROHS
C108, C208	2	CAP,SMD,0402,15pF,50V,5%,NP0,ROHS
C109, C209	2	CAP,SMD,0402,820pF,50V,10%,X7R,ROHS
C110, C210	2	CAP,SMD,0402,470pF,50V,10%,X7R,ROHS
C111, C211	2	CAP,SMD,0805,4.7uF,16V,10%,X7R,ROHS
C112, C113	2	CAP,SMD,0805,DNP-PLACE HOLDER,ROHS
D1, D3	2	DIODE-SCHOTTKY,SMD,SOT23,3P,30V,200mA,SINGLE DIODE
D2, D4	2	DIODE-RECTIFIER,SMD,POWER DI5,3P,60V,5A,ROHS
D100, D200	2	DIODE-RECTIFIER,SMD,SOD-323,2P,75V,150mA,ROHS
JP1, JP2, JP3	3	CONN-HEADER,1X2,RETENTIVE,2.54mm,0.230X0.120,ROHS
J1	1	CONN-GEN,BIND.POST,INSUL-RED,THMBNUT-GND
J2	1	CONN-GEN,BIND.POFST,INSUL-BLK,THMBNUT-GND
P1, P2, J3, J4, J5, J6	6	CONN-TURRET, TERMINAL POST, TH,ROHS
J7, J8, J9, J10	4	CONN-SCOPE PROBE TEST PT,COMPACT,PCB MNT,ROHS
LED1, LED2	2	LED-GaAs RED,SMD,2X1.25mm,100mW,40mA,10mcd,ROHS
L100, L200	2	COIL-PWR INDUCTOR, SMD, 8.3mm, 4.7uH, 30%, 3.4A, ROHS, SHIELDED
Q1, Q2, Q4, Q5	4	TRANSISTOR,NPN,3LD,SOT23,40V,600mA,ROHS
Q3, Q6	2	TRANSISTOR,N-CHANNEL,3LD,SOT-23,60V,115mA,ROHS
R1, R6	2	RES,SMD,0402,75ohm,1/16W,5%,TF,ROHS
R2, R4	2	RES,SMD,0402,5.49K,1/16W,1%,TF,ROHS
R3, R5	2	RES,SMD,0402,36ohm,1/16W,5%,TF,ROHS
R100, R105, R205	3	RES,SMD,0402,0ohm,1/16W,5%,TF,ROHS
R101, R102, R201, R202	4	RES,SMD,0402,10K,1/16W,1%,TF,ROHS
R103, R107, R200, R207	4	RES,SMD,0402,DNP,DNP,DNP,TF,ROHS
R104, R204	2	RES,SMD,0402,95.3K,1/16W,1%,TF,ROHS
R108, R109, R208, R209	4	RES,SMD,0402,28K,1/16W,1%,TF,ROHS
R110, R210	2	RES,SMD,0402,1.4K,1/16W,1%,TF,ROHS
R111, R211	2	RES,SMD,0402,6.04K,1/10W,1%,TF,ROHS
R112, R212, R113, R114	4	RES,SMD,0603,10ohm,1/10W,1%,TF,ROHS
R203	1	RES,SMD,0402,4.99K,1/16W,1%,TF,ROHS
S1	1	SWITCH-DIP,SMD,4P,SLIDE,SPST,LP,ROHS
TP3, TP100, TP103, TP104, TP105 TP109, TP110, TP111, TP112, TP200, TP203, TP204, TP205 TP209, TP210, TP211, TP212	17	CONN-MINI TEST POINT,VERTICAL,WHITE,ROHS
U100, U200		IC-2A BUCK REGULATOR,24P,QFN,4X4,ROHS

Test Recommendations

To guarantee measurement accuracy, the following precautions should be observed:

1. Make all input and output voltage measurements at the board using the test points provided.
2. Measure input and output current with series ammeters or accurate shunt resistors. This is especially important when measuring efficiency.
3. Use a low-loop-inductance scope probe tip similar to the one shown below to measure switching signals and input / output ripple to avoid noise coupling into the probe ground lead. Input ripple, output ripple, and load transient deviation are best measured near the respective input / output capacitors. For more accurate ripple measurement, please see Enpirion App Note regarding this subject.

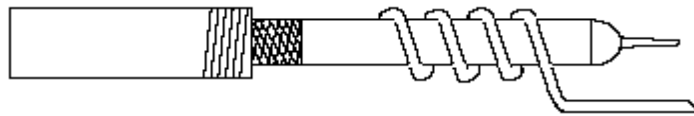

4. The board includes a pull-up resistor for the POK signal and ready to monitor the power OK status at clip lead marked POK.

Contact Information

Altera Corporation
101 Innovation Drive
San Jose, CA 95134
Phone: 408-544-7000
www.altera.com

© 2013 Altera Corporation—Confidential. All rights reserved. ALTERA, ARRIA, CYCLONE, ENPIRION, HARDCOPY, MAX, MEGACORE, NIOS, QUARTUS and STRATIX words and logos are trademarks of Altera Corporation and registered in the U.S. Patent and Trademark Office and in other countries. All other words and logos identified as trademarks or service marks are the property of their respective holders as described at www.altera.com/common/legal.html. Altera warrants performance of its semiconductor products to current specifications in accordance with Altera's standard warranty, but reserves the right to make changes to any products and services at any time without notice. Altera assumes no responsibility or liability arising out of the application or use of any information, product, or service described herein except as expressly agreed to in writing by Altera. Altera customers are advised to obtain the latest version of device specifications before relying on any published information and before placing orders for products or services.