



Chipsmall Limited consists of a professional team with an average of over 10 year of expertise in the distribution of electronic components. Based in Hongkong, we have already established firm and mutual-benefit business relationships with customers from,Europe,America and south Asia,supplying obsolete and hard-to-find components to meet their specific needs.

With the principle of “Quality Parts,Customers Priority,Honest Operation,and Considerate Service”,our business mainly focus on the distribution of electronic components. Line cards we deal with include Microchip,ALPS,ROHM,Xilinx,Pulse,ON,Everlight and Freescale. Main products comprise IC,Modules,Potentiometer,IC Socket,Relay,Connector.Our parts cover such applications as commercial,industrial, and automotives areas.

We are looking forward to setting up business relationship with you and hope to provide you with the best service and solution. Let us make a better world for our industry!



Contact us

Tel: +86-755-8981 8866 Fax: +86-755-8427 6832

Email & Skype: info@chipsmall.com Web: www.chipsmall.com

Address: A1208, Overseas Decoration Building, #122 Zhenhua RD., Futian, Shenzhen, China



Description

This is the EY1603TI User Guide. The EY1603TI features a wide VIN range of 6V to 40V, voltage reference accurate to ±1%, and Thermal Shutdown and current Limit

Protection. The evaluation board is optimized for engineering ease of testing through programming options, clip leads, test points, etc.

Evaluation Board Over View

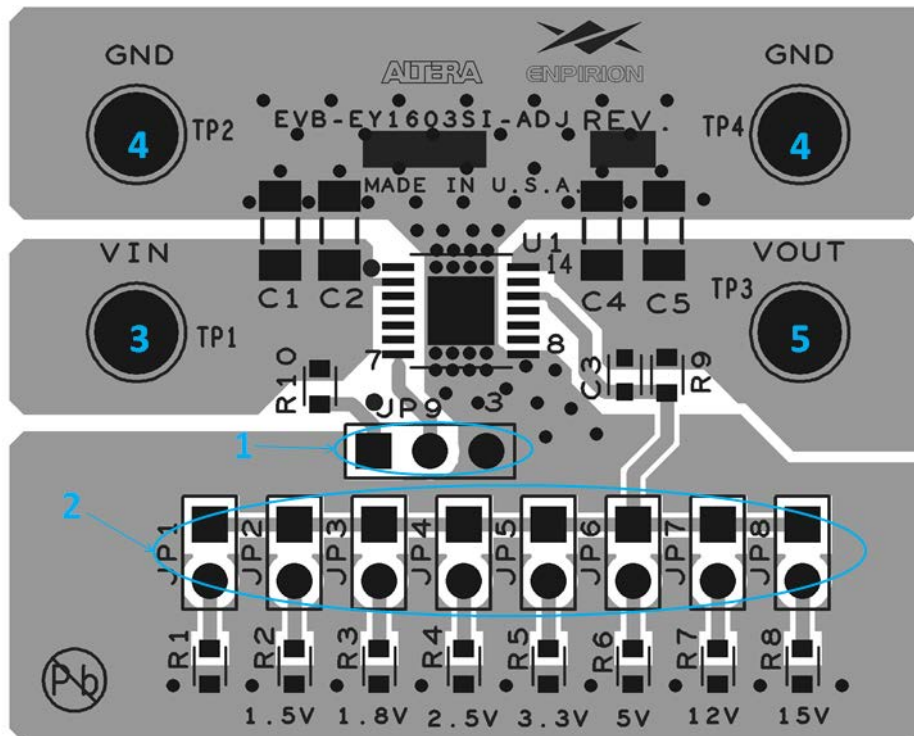

Figure 1. EY1603TI Evaluation Board Illustration

Instructions

The numbers in the instructions below correspond to the numbers in Figure 1. By following the number sequence below, the device can be turned on by step 5.

- 1) **ENABLE** – The jumper on the left two pins of JP9 enables the device through the resistor R10. The jumper on the right two pins of JP9 disables the device.
- 2) **Output Voltage Settings (JP1-JP8)** - The jumper may be switched to change the output voltage. From left to right R1 to R8 (1.5V-15V). The EY1603TI-ADJ output voltage is programmed using an external resistor divider.

$$V_{out} = 1.223V * \left(\frac{R9}{R1} + 1 \right)$$

- 3) **VIN (TP1)** - Connect 6V to 40V supply on TP1. Do not turn on until everything is connected correctly.
- 4) **Ground (TP2 and TP4)** - Connect the input ground to TP2 and the output ground to TP4.
- 5) **VOUT (TP3)** - Connect the load to TP3. If the instructions were followed up to this point, the device may be powered to turn on.

Evaluation Board Schematic

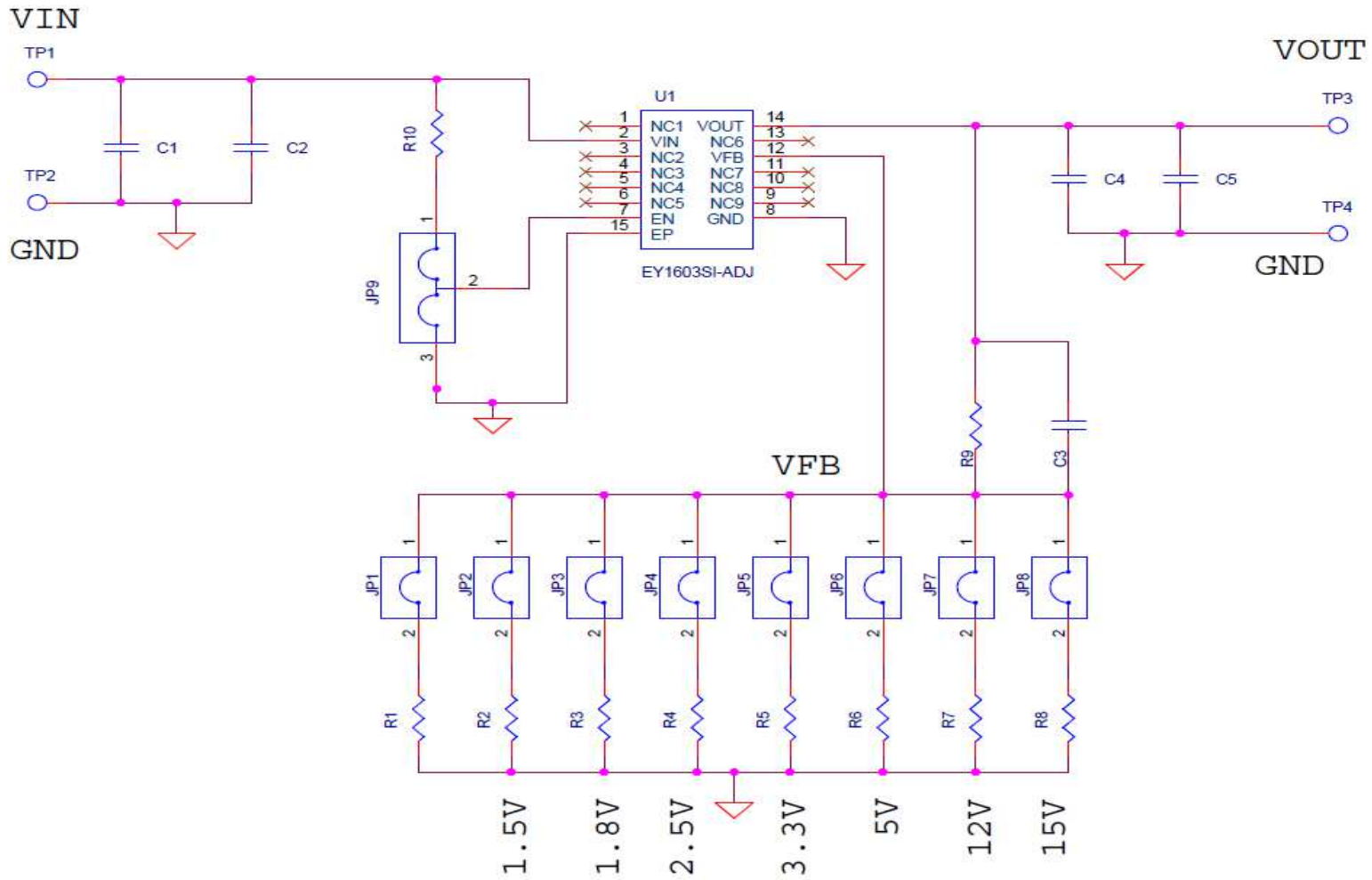

Bill of Materials

Designator	Qty	Description
C1, C2, C4, C5	4	CAP,SMD,1206,10uF,50V,10%,X5R,ROHS
C3	1	CAP,SMD,0603,47pF,50V,5%,C0G,NP0,ROHS
JP1, JP2, JP3, JP4, JP5, JP6, JP7, JP8	8	CONN-HEADER,1X2,RETENTIVE,2.54mm,0.230X 0.120,ROHS
JP9	1	CONN-HEADER,1x3,BREAKAWY 1X36,2.54mm,ROHS
R1	1	RES,SMD,0603,DNP-PLACE HOLDER,ROHS
R2	1	RES,SMD, 0603, 60.4K, 1/10W,1%,TF,ROHS
R3	1	RES,SMD,0603,30.1K,1/10W,1%,TF,ROHS
R4	1	RES,SMD,0603, 14K,1/10W,1%,TF,ROHS
R5	1	RES,SMD,0603, 8.66K,1/10W,1%,TF,ROHS
R6	1	RES,SMD,0603,4.75K,1/10W,1%,TF,ROHS
R7	1	RES,SMD,0603, 1.65K, 1/10W, 1%, TF,ROHS
R8	1	RES,SMD,0603, 1.3K, 1/10W,1%,TF,ROHS
R9	1	RES,SMD,0603,15K,1/10W,1%,TF,ROHS
R10	1	RES, SMD, 0603, 10K, 1/10W, 1%, TF,ROHS
TP1, TP2, TP3, TP4	4	CONN-TURRET,TERMINAL POST,TH,ROHS
U1	1	IC-40V LDO ADJ. LINEAR REGULATOR,14P,HTSSOP ,ROHS

Test Recommendations

To guarantee measurement accuracy, the following precautions should be observed:

1. Make all input and output voltage measurements at the board using the test points provided (TP1 to TP4). This will eliminate voltage drop across the line and load cables that can produce false readings.
2. Measure input and output current with series ammeters or accurate shunt resistors. This is especially important when measuring efficiency.
3. Use a low-loop-inductance scope probe tip similar to the one shown below to measure input / output ripple to avoid noise coupling into the probe ground lead. Input ripple, output ripple, and load transient deviation are best measured near the respective input / output capacitors. For more accurate ripple measurement, please see Enpirion App Note regarding this subject.
4. In “always-on” applications, EN should be tied to VIN through R10.

Contact Information

Altera Corporation
101 Innovation Drive
San Jose, CA 95134
Phone: 408-544-7000
www.altera.com

© 2013 Altera Corporation—Confidential. All rights reserved. ALTERA, ARRIA, CYCLONE, ENPIRION, HARDCOPY, MAX, MEGACORE, NIOS, QUARTUS and STRATIX words and logos are trademarks of Altera Corporation and registered in the U.S. Patent and Trademark Office and in other countries. All other words and logos identified as trademarks or service marks are the property of their respective holders as described at www.altera.com/common/legal.html. Altera warrants performance of its semiconductor products to current specifications in accordance with Altera's standard warranty, but reserves the right to make changes to any products and services at any time without notice. Altera assumes no responsibility or liability arising out of the application or use of any information, product, or service described herein except as expressly agreed to in writing by Altera. Altera customers are advised to obtain the latest version of device specifications before relying on any published information and before placing orders for products or services.