



Chipsmall Limited consists of a professional team with an average of over 10 year of expertise in the distribution of electronic components. Based in Hongkong, we have already established firm and mutual-benefit business relationships with customers from,Europe,America and south Asia,supplying obsolete and hard-to-find components to meet their specific needs.

With the principle of “Quality Parts,Customers Priority,Honest Operation,and Considerate Service”,our business mainly focus on the distribution of electronic components. Line cards we deal with include Microchip,ALPS,ROHM,Xilinx,Pulse,ON,Everlight and Freescale. Main products comprise IC,Modules,Potentiometer,IC Socket,Relay,Connector.Our parts cover such applications as commercial,industrial, and automotives areas.

We are looking forward to setting up business relationship with you and hope to provide you with the best service and solution. Let us make a better world for our industry!



Contact us

Tel: +86-755-8981 8866 Fax: +86-755-8427 6832

Email & Skype: info@chipsmall.com Web: www.chipsmall.com

Address: A1208, Overseas Decoration Building, #122 Zhenhua RD., Futian, Shenzhen, China



RT4532 Evaluation Board

Purpose

The RT4532 is a high-efficiency LED driver for backlight applications with an internal schottky diode and current source driver.

It supports linear mappings with 256 steps to setup the brightness of backlight LEDs. It also supports PWM dimming to adjust the brightness. This document explains the function and use of the RT4532 evaluation board (EVB) and provides information to enable operation and modification of the evaluation board and circuit to suit individual requirements.

Table of Contents

Purpose	1
Introduction.....	2
Key Performance Summary Table	2
Bench Test Setup Conditions	3
Schematic, Bill of Materials & Board Layout	5
More Information.....	8
Important Notice for Richtek Evaluation Board	8

Introduction

General Product Information

The RT4532 is a high-efficiency LED driver for backlight applications. An asynchronous boost converter with an internal Schottky diode and a current source driver are designed to support 6LED/channel with wide input voltage range from 2.5V to 5.5V.

This document explains the function and use of the RT4532 evaluation board (EVB) and provides information to enable operation and modification of the evaluation board and circuit to suit individual requirements.

Product Feature

- Input Voltage Range : 2.5V to 5.5V
- Internal Schottky Diode
- Fast-speed mode I²C Compatible Interface
- Drive Up to 6 WLEDs in 4 String
- External PWM Brightness Control
- 550k/1.1MHz Switching Frequency
- Built-in Internal Soft-Start
- I²C Programmable 256 Steps Linear Current Regulation
- Up to 85% Efficiency with Small Magnetics
- Programmable 16V/24V OVP
- Current Accuracy $\pm 5\%$ and Current Balance $\pm 3\%$
- UVLO, OVP, OCP, OTP Protection
- Shutdown Current : $< 1\mu\text{A}$
- Temperature Range : -40°C to 85°C

Key Performance Summary Table

Key Features		Evaluation Board Number: PCB015_V1
Default Input Voltage	2.5V~5.5V	
Max Output Current	20mA/40mA	
Default Output Voltage	17V	
Default Marking & Package Type	RT4532	
Operation Frequency	Steady 1.1MHz at all loads	
Protection	UVLO OVP OCP Thermal Shutdown	

Bench Test Setup Conditions

Headers Description and Placement



Please carefully inspect the EVB IC and external components, comparing them to the following Bill of Materials, to ensure that all components are installed and undamaged. If any components are missing or damaged during transportation, please contact the distributor or send e-mail to evb_service@richtek.com

Test Points

The EVB is provided with the test points and pin names listed in the table below.

Pin No.	Pin Name	Comment (expected waveforms or voltage levels on test points)
A2	GND	Ground.
B1	VOUT	Power Output of the Asynchronous Boost Converter for Backlight LEDs. Connect a 1 μ F or larger ceramic capacitor from VOUT to ground.
B2	VIN	Power Input. Connect this pin to the input power supply voltage. Connect a 10 μ F or larger ceramic capacitor from the VIN to ground.
C1	PWM	PWM Dimming Input for Backlight LED.
C2	EN	Enable Control Input (Active High). The chip is in shutdown mode when the EN pin is low.
D1	SDA	I ² C Serial Data Input/Output. An external pull-up resistor is required.
D2	SCL	I ² C Serial Data Input/Output. An external pull-up resistor is required.
E1	FB2	Single Output 2 for Backlight LED.
E2	FB1	Single Output 1 for Backlight LED.

Power-up & Measurement Procedure

1. Apply 3.6V nominal input power supply ($2.5V < V_{IN} < 5.5V$) to the VIN and GND terminals.
2. The EN voltage is pulled to logic high by internal circuit to enable operation. Drive EN high ($>1.05V$) to enable operation or low ($<0.4V$) to disable operation. Pull EN pin to High pin that make EN voltage equal to VIN.
3. There is a 2-pin header JP2 "EN" for enable control. To use a jumper at "H" option to tie EN test pin to input power VIN for enabling the device. Inversely, to use a jumper at "L" option to tie EN test pin and ground GND for disabling the device.
4. The JP4 is the I²C control pin that includ SDA, SCL, GND pin, and it need to connect to Richtek WrenBoard when use the RT4532 I²C dimming.
5. The I_{LED} setting supports I²C dimming and PWM dimming as below.

Output I_{LED} Setting

1. Linear Brightness Dimming

The chip is built-in an I²C 8-bit resolution brightness control with maximum 20mA/40mA selection. Reg0x02 <3> corresponds to full-scale LED current control. Reg0x04 <7:0> sets 8bits resolution brightness dimming control.

$$I_{LED} = \frac{\text{Code}}{255} \times I_{LED, Full}$$

Where

I_{LED, Full} : the full-scale LED current set by Reg0x02 <3>.

Code : the 8bit brightness code Reg0x04 <7:0> programmed by I²C interface.

2. PWM Brightness Dimming

Besides programmable built-in I²C backlight LED current control, the RT4532 features a built-in PWM dimming current control by setting Reg0x02 <6> to 1, offering a linear current dimming by external clock source. In order to guarantee the PWM dimming resolution (7 bit at > 15kHz application), recommending dimming frequency have to be operated at range of 400Hz to 20kHz.

3. LED Short Protection

LED short protection prevents abnormal connection to cause IC damage avoiding FB1/FB2 connecting power supply. And, If unbalanced LEDs series (cause FB1 or FB2 > 9.6V) is different between channel1 and channel2, IC will also occur LED short event. As LED short event occur more than deglitch time 2ms, IC will shut-down latch until IC is reset by EN pin.

Schematic, Bill of Materials & Board Layout

EVB Schematic Diagram

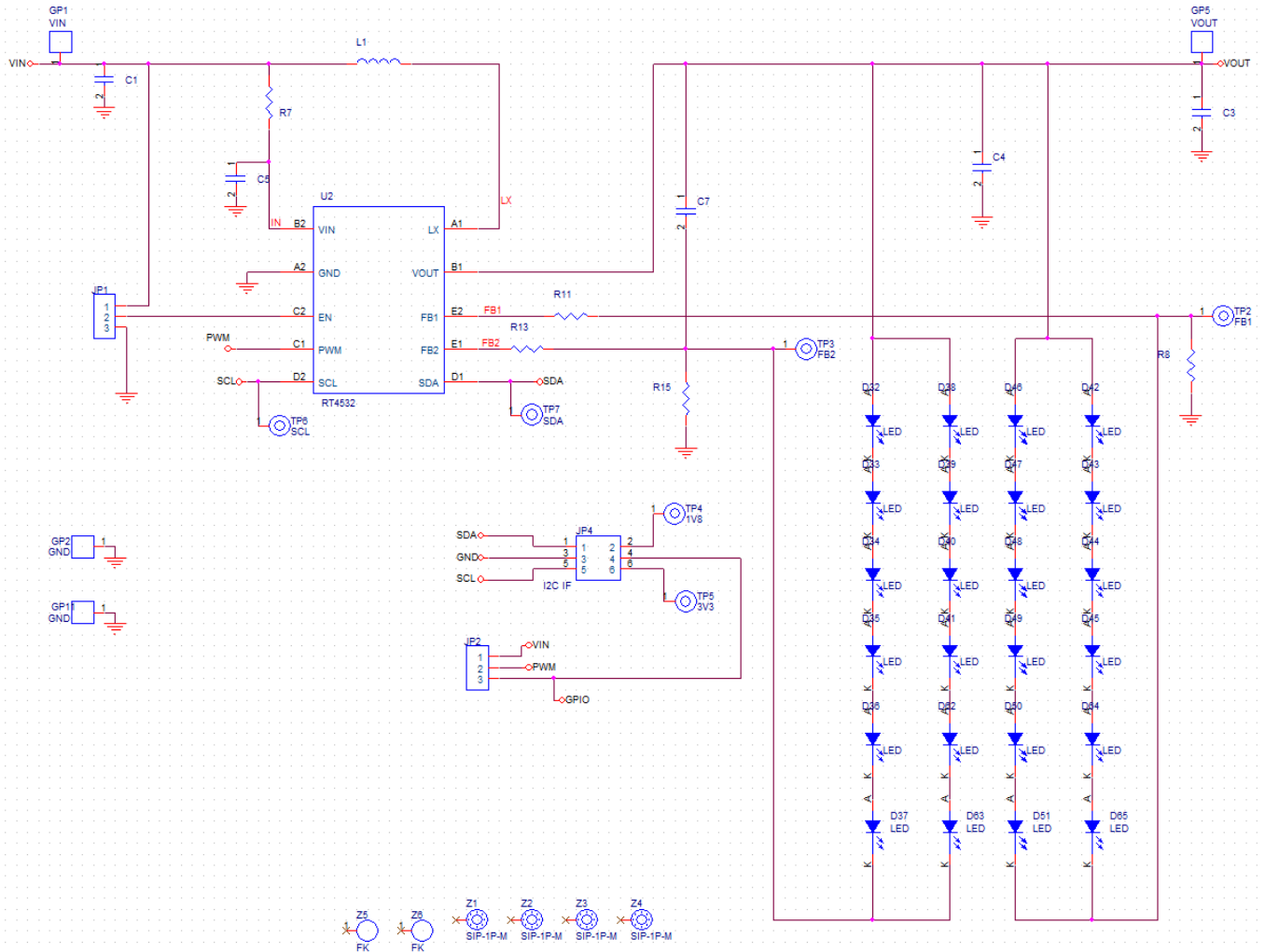

Bill of Materials

Reference	Qty	Part Number	Description	Package	Manufacture
U2	1	RT4532	DC-DC Converter	CSP-10B 0.87x2.07	RICHTEK
L1	1	NR4018T100M	10 μ H/1.2A/ \pm 20%, DCR = 0.18 Ω , Inductor	4mm x 4mm x 1.8mm	TAIYO YUDEN
C1	1	0603X106M6R3	10 μ F/ \pm 20%/ 6.3V/X5R Ceramic Capacitor	0603	WALSIN
C3	1	C2012X7R1H105KT	1 μ F/ \pm 10%/50V/X7R Ceramic Capacitor	0805	TDK
R7	1		Short		
R11	1		Short		
R13	1		Short		
D32, D34, D36, D33, D35, D37, D38, D40, D62, D39, D41, D63, D46, D48, D50, D47, D49, D51, D42, D44, D64, D43, D45, D65	24		LED		
TP	6	3V3, SCL, SDA, 1V8, FB1, FB2	Test Pin		
GP	4	VIN, GND, GND, VOUT	Golden Pin		
JP	3	JP1, JP2, JP4			

EVB Layout

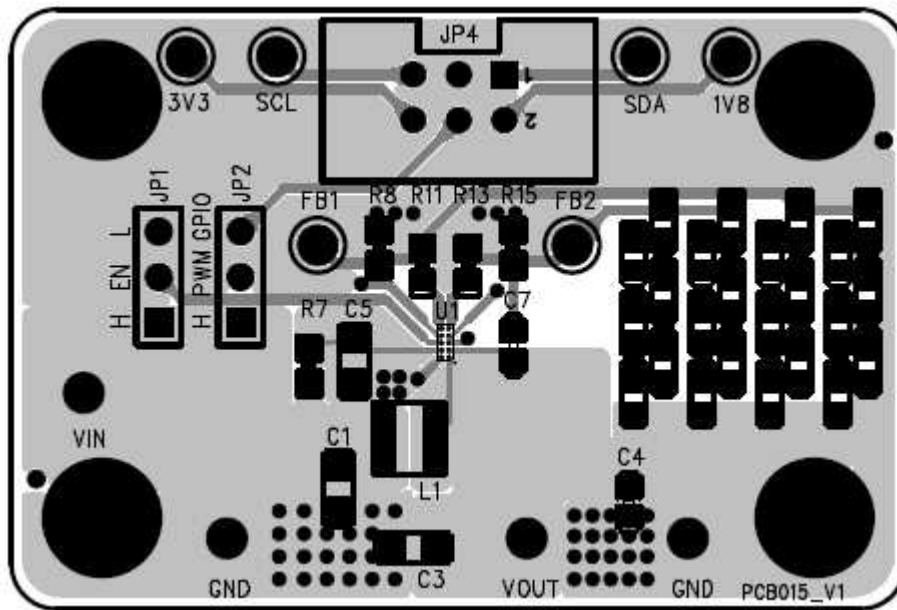

PCB Layout—Top View

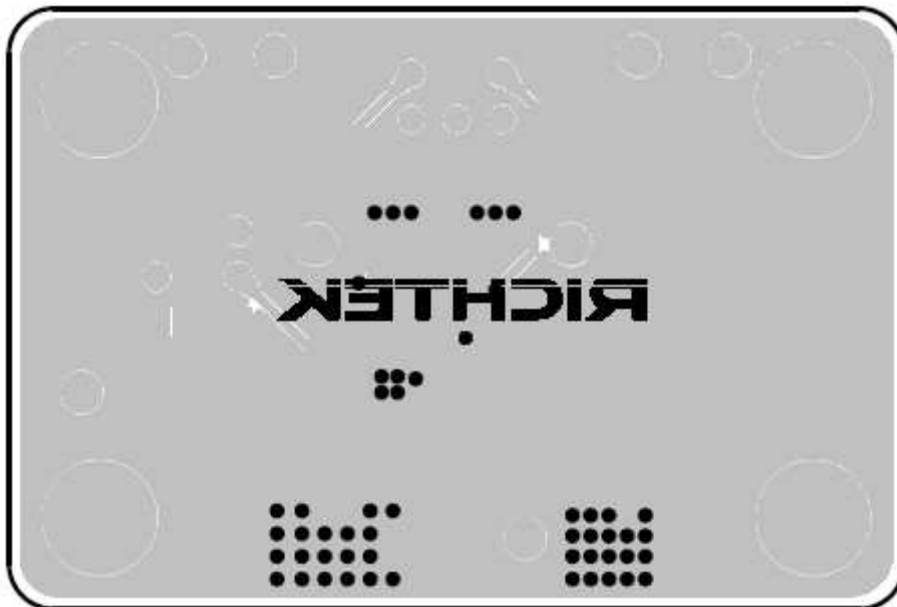

PCB Layout—Bottom Side

More Information

For more information, please find the related datasheet or application notes from Richtek website <http://www.richtek.com>.

Important Notice for Richtek Evaluation Board

THIS DOCUMENT IS FOR REFERENCE ONLY, NOTHING CONTAINED IN THIS DOCUMENT SHALL BE CONSTRUED AS RICHTEK'S WARRANTY, EXPRESS OR IMPLIED, UNDER CONTRACT, TORT OR STATUTORY, WITH RESPECT TO THE PRESENTATION HEREIN. IN NO EVENT SHALL RICHTEK BE LIABLE TO BUYER OR USER FOR ANY AND ALL DAMAGES INCLUDING WITHOUT LIMITATION TO DIRECT, INDIRECT, SPECIAL, PUNITIVE OR CONSEQUENTIAL DAMAGES.