



Chipsmall Limited consists of a professional team with an average of over 10 year of expertise in the distribution of electronic components. Based in Hongkong, we have already established firm and mutual-benefit business relationships with customers from,Europe,America and south Asia,supplying obsolete and hard-to-find components to meet their specific needs.

With the principle of “Quality Parts,Customers Priority,Honest Operation,and Considerate Service”,our business mainly focus on the distribution of electronic components. Line cards we deal with include Microchip,ALPS,ROHM,Xilinx,Pulse,ON,Everlight and Freescale. Main products comprise IC,Modules,Potentiometer,IC Socket,Relay,Connector.Our parts cover such applications as commercial,industrial, and automotives areas.

We are looking forward to setting up business relationship with you and hope to provide you with the best service and solution. Let us make a better world for our industry!



Contact us

Tel: +86-755-8981 8866 Fax: +86-755-8427 6832

Email & Skype: info@chipsmall.com Web: www.chipsmall.com

Address: A1208, Overseas Decoration Building, #122 Zhenhua RD., Futian, Shenzhen, China



Asynchronous Boost Converter for 10 WLEDs

Purpose

The RT4533A is a highly integrated LED driver IC capable of driving 10 WLEDs in series. It is composed of a current mode Boost converter integrated with a 36.5V/1.2A power switch. For brightness dimming, the RT4533A supports PWM dimming which determines the feedback reference voltage.

Table of Contents

Purpose.....	1
Introduction.....	2
Key Performance Summary Table.....	2
Bench Test Setup Conditions.....	3
Schematic, Bill of Materials & Board Layout.....	5
More Information.....	7
Important Notice for Richtek Evaluation Board.....	7

Introduction

General Product Information

The RT4533A is a highly integrated LED driver IC capable of driving 10 WLEDs in series. It is composed of a current mode Boost converter integrated with a 36.5V/1.2A power switch. The RT4533A supports a wide input voltage range from 2.5V to 5.5V and runs at a fixed frequency of 1.1MHz. The LED current is set via an external resistor and the feedback voltage is regulated to 300mV. For brightness dimming, the RT4533A supports PWM dimming which determines the feedback reference voltage.

Product Features

- 2.5V to 5.5V Input Voltage Range
- 36.5V Open LED Protection for 10 WLEDs
- PWM Dimming Brightness Control
- 300mV Reference Voltage with $\pm 2\%$ Accuracy
- 1.1MHz Switching Frequency
- Built-In Soft-Start
- Over-Temperature Protection
- Internal Compensation
- Current Limit
- RoHS Compliant and Halogen Free

Key Performance Summary Table

Key Features	Evaluation Board Number : PCB072_V1
Default Input Voltage	2.5V to 5.5V
Max Output Current	20mA
Default Output Voltage	36.5V
Default Marking & Package Type	RT4533AGJ6, TSOT-23-6
Operation Frequency	Steady 1.1MHz at all loads
Protection	UVLO, OVP, OCP, Thermal Shutdown

Bench Test Setup Conditions

Headers Description and Placement

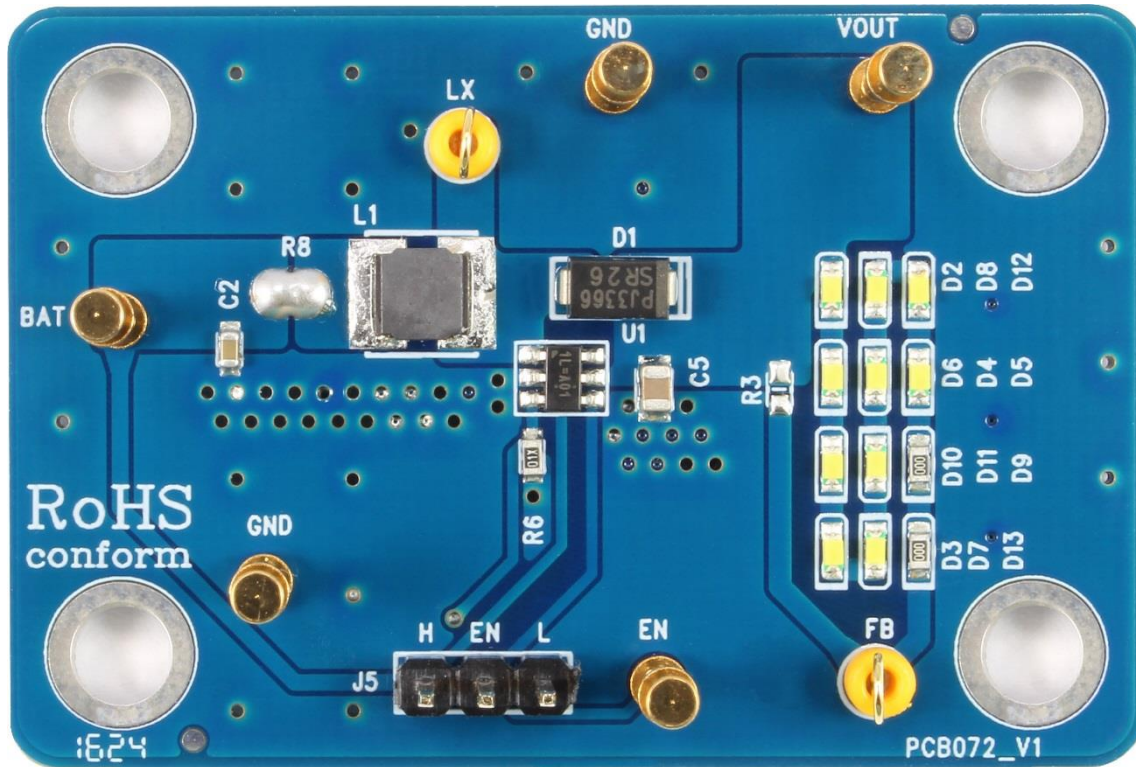

Carefully inspect all the components used in the EVB according to the following Bill of Materials table, and then make sure all the components are undamaged and correctly installed. If there is any missing or damaged component, which may occur during transportation, please contact our distributors or e-mail us at evb_service@richtek.com.

Test Points

The EVB is provided with the test points and pin names listed in the table below.

Test Point/ Pin Name	Signal Name	Description
LX	Switch Node	This is the switching node of the IC. Connect the switched side of the inductor to LX. This pin is also used to sense the output voltage for open LED protection.
GND	Ground	Ground.
FB	Feedback Voltage Input	Connect the sense resistor from FB to GND.
EN	Enable Control Input	Control pin of the boost converter. It is a multifunctional pin which can be used for enable control and PWM dimming.
VOUT	Output Voltage	The output supply pin for the IC.
VIN	Supply Voltage Input	The input supply pin for the IC. Support 2.5V to 5.5V Input Voltage.

Power-Up & Measurement Procedure

1. Apply 3.6V nominal input power supply ($2.5V < V_{IN} < 5.5V$) to the VIN and GND terminals.
2. The EN voltage is pulled to logic high by internal circuit to enable operation. Drive EN high ($>1.05V$) to enable operation or low ($<0.4V$) to disable operation. Pull EN pin to High pin that make EN voltage equal to VIN.
3. There is a 2-pin header JP2 “EN” for enable control. To use a jumper at “H” option to tie EN test pin to input power VIN for enabling the device. Inversely, to use a jumper at “L” option to tie EN test pin and ground GND for disabling the device.
4. The JP5 is the PWM control pin.
5. The ILED setting supports PWM dimming as below.

Output ILED Setting

1. PWM Brightness Dimming

The EN pin is used for the control input for both PWM dimming mode and digital dimming mode. Shutdown delay when the EN voltage is logic low for more than specific time, the driver will be shut down.

2. OCP

The driver provides cycle-by-cycle current limit function to control the current on power switch. The boost switch turns off when the inductor current reaches this current threshold and it remains off until the beginning of the next switching cycle. This protects the RT4533A and external component under overload conditions.

3. OVP

The Over Voltage Protection is detected by a resistor divider circuit from VOUT. Once VOUT goes over the OVP voltage, LX pin stops switching and the power N-MOSFET will be turned off. Then, the VOUT will be discharged by external resistor. OVP will be released until EN goes from Lo to Hi again.

4. OTP

As the die temperature is higher than $160^{\circ}C$, the chip also will enter protection mode. The power MOSFET will be turned off during protection mode to prevent abnormal operation. The device is released from shutdown automatically when the junction temperature decreases by $15^{\circ}C$.

Schematic, Bill of Materials & Board Layout

EVB Schematic Diagram

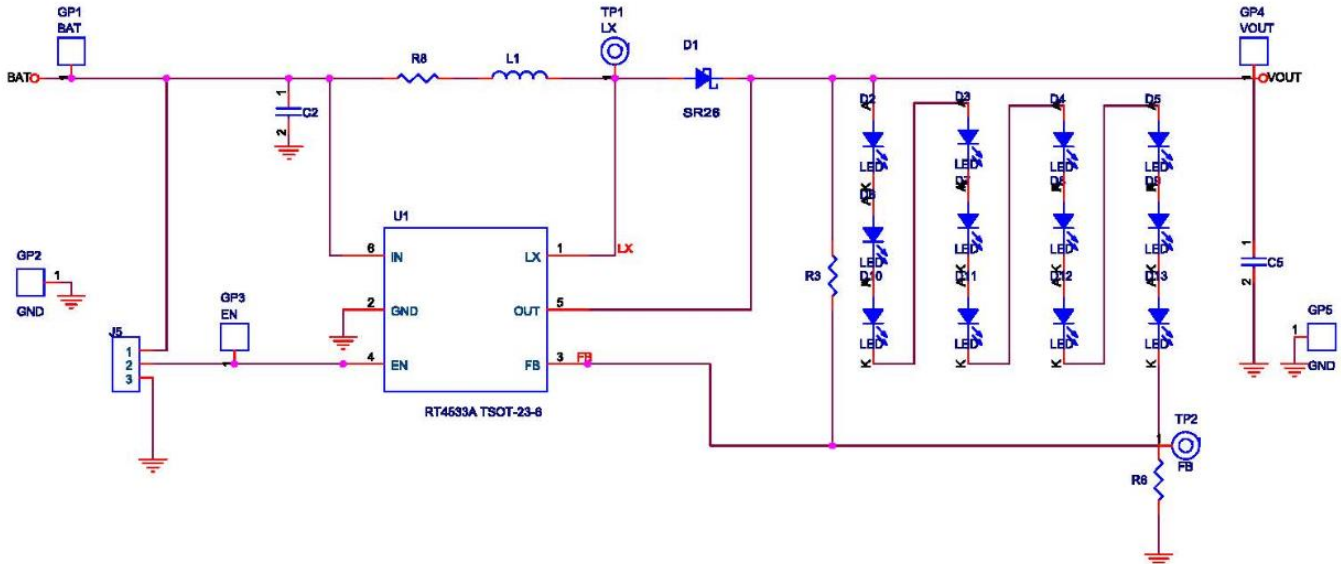

Bill of Materials

Reference	Qty	Part Number	Description	Package	Manufacturer
U1	1	RT4533AGJ6	DC-DC Converter	TSOT-23-6	RICHTEK
L1	1	NR4018T220M	22 μ H	L-SH4018	TAIYO YUDEN
C2	1	C0603X5R1E225DT	2.2 μ F/16V/X5R/0603 Capacitor Ceramic	C-0603	TDK
C5	1	GMK107BJ105KA	1 μ F/50V/X5R/0805 Capacitor Ceramic	C-0805	TAIYO YUDEN
D1	1	SR26	Schottky Diode	D-1206	PANJIT
R3			NC		
R6	1	0603 10R0 1%	Resistor, 1%, 10 Ω	R-0603	WALSIN
R8	1		Short		
D9, D13	2	0603 JUMP	Resistor, 1%, 0 Ω	D-0603	WALSIN
D2, D3, D4, D5, D6, D7, D8, D10, D11, D12	10	LNL-190UW-4H	WLED	D-0603	光楠

EVB Layout

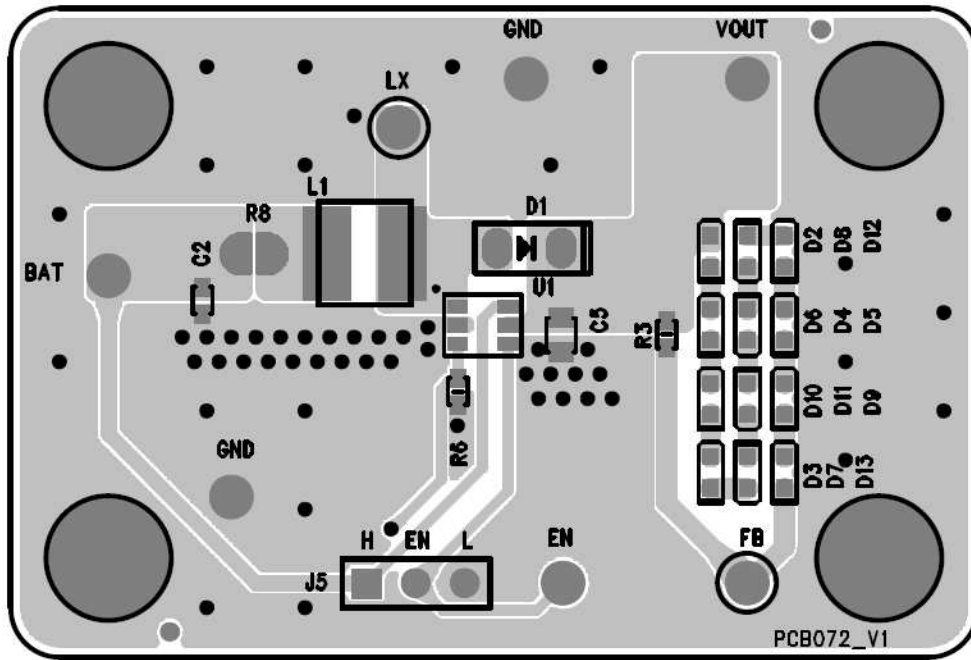

Top View

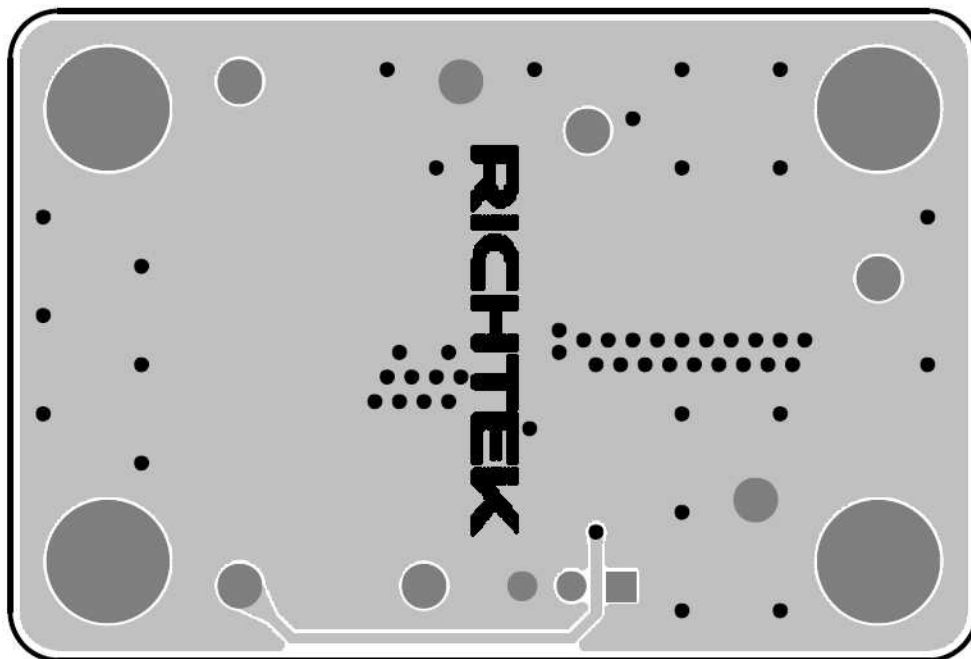

Bottom View

More Information

For more information, please refer to the related datasheets or application notes from Richtek website <http://www.richtek.com>.

Important Notice for Richtek Evaluation Board

THIS DOCUMENT IS FOR REFERENCE ONLY, NOTHING CONTAINED IN THIS DOCUMENT SHALL BE CONSTRUED AS RICHTEK'S WARRANTY, EXPRESS OR IMPLIED, UNDER CONTRACT, TORT OR STATUTORY, WITH RESPECT TO THE PRESENTATION HEREIN. IN NO EVENT SHALL RICHTEK BE LIABLE TO BUYER OR USER FOR ANY AND ALL DAMAGES INCLUDING WITHOUT LIMITATION TO DIRECT, INDIRECT, SPECIAL, PUNITIVE OR CONSEQUENTIAL DAMAGES.