



Chipsmall Limited consists of a professional team with an average of over 10 year of expertise in the distribution of electronic components. Based in Hongkong, we have already established firm and mutual-benefit business relationships with customers from,Europe,America and south Asia,supplying obsolete and hard-to-find components to meet their specific needs.

With the principle of “Quality Parts,Customers Priority,Honest Operation,and Considerate Service”,our business mainly focus on the distribution of electronic components. Line cards we deal with include Microchip,ALPS,ROHM,Xilinx,Pulse,ON,Everlight and Freescale. Main products comprise IC,Modules,Potentiometer,IC Socket,Relay,Connector.Our parts cover such applications as commercial,industrial, and automotives areas.

We are looking forward to setting up business relationship with you and hope to provide you with the best service and solution. Let us make a better world for our industry!



## Contact us

Tel: +86-755-8981 8866 Fax: +86-755-8427 6832

Email & Skype: info@chipsmall.com Web: www.chipsmall.com

Address: A1208, Overseas Decoration Building, #122 Zhenhua RD., Futian, Shenzhen, China



## **3A, 18V Synchronous Step-Down Converter with Adjustable Current Limited Power Switch**

### ***Purpose***

The RT7249 is a current mode step-down converter with the input voltage range from 4.5V to 18V and provides 3A output current. This document explains the function and use of the RT7249 evaluation board (EVB), and provides information to enable operation, modification of the evaluation board and circuit to suit individual requirements.

## **Table of Contents**

Purpose .....	1
Introduction.....	2
Key Performance Summary Table .....	2
Bench Test Setup Conditions .....	3
Schematic, Bill of Materials & Board Layout .....	5
More Information.....	9
Important Notice for Richtek Evaluation Board .....	9

## Introduction

### General Product Information

The RT7249 is a high efficiency, monolithic synchronous step-down DC/DC converter with a power switch. The buck converter can deliver up to 3A output current from 4.5V to 18V input supply. The RT7249's current-mode architecture and external compensation allow the transient response to be optimized over a wide input range and loads. Cycle-by-cycle current limit provides protection against shorted output and soft-start eliminates input current surge during start-up. The RT7249 also provides under-voltage protection and thermal shutdown. PWM frequency is adjustable by the ROSC pin and Power Switch current limit can also be adjusted by the RLIM pin. The low current (<3 $\mu$ A) in shutdown mode provides output disconnection, enabling easy power management in battery-powered systems. The RT7249 is available in the WQFN-16L 4x4 package.

### Product Feature

- **Buck Regulator**
  - ▶ 4.5V to 18V Input Voltage Range
  - ▶ 3A Output Current
  - ▶ Internal N-Chanel MOSFETs
  - ▶ Current Mode Control
  - ▶ Adjustable PWM Frequency
  - ▶ Adjustable Output from 0.8V to 15V
  - ▶ Adjustable Soft-Start Time
  - ▶ Stable with Ceramin Output Capactiors
  - ▶ Cycle-by-Cycle Current Limit
  - ▶ Input Under-Voltage Lockout
  - ▶ Output Under-Voltage Protection
  - ▶ Thermal Shutdown
- **Power Switch**
  - ▶  $\pm 15\%$  Current-Limit Accuracy at 1.2A
  - ▶ Adjustable Current Limit : 75mA to 2580mA
  - ▶ Meet USB Current-Limiting Requirements
  - ▶ Reverse Input-Output Voltage Protection
  - ▶ Built Soft-Start
  - ▶ 120m $\Omega$  High-Side MOSFET
  - ▶ Operating Range : 2.5V to 5.5V

### Key Performance Summary Table

Key Features	Evaluation Board Number : PCB067_V1
Default Input Voltage	12V
Max Output Current	3A
Default Output Voltage	5V
Default Marking & Package Type	RT7249GQW, WQFN-16L 4x4
Operation Frequency	500kHz Switching Frequency

**Bench Test Setup Conditions**

**Headers Description and Placement**

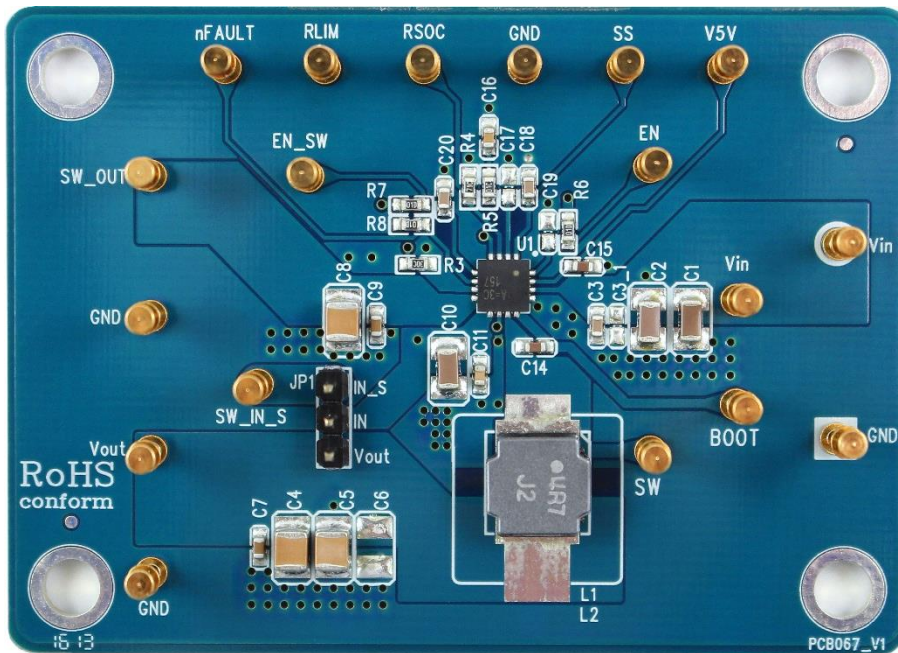

Please carefully inspect the EVB IC and external components, comparing them to the following Bill of Materials, to ensure that all components are installed and undamaged. If any components are missing or damaged during transportation, please contact the distributor or send e-mail to [evb\\_service@richtek.com](mailto:evb_service@richtek.com).

**Test Points**

The EVB is provided with the test points and pin names listed in the table below.

Test point/ Pin name	Signal	Comment (expected waveforms or voltage levels on test points)
<b>VIN</b>	Input voltage	Power Input. Supply voltage range is from 4.5V to 18V. Must bypass with a suitable large ceramic capacitor.
<b>PGND</b>	Ground	Power Ground. The exposed pad must be soldered to a large PCB and connected to PGND for maximum thermal dissipation.
<b>AGND</b>	Ground	Analog Ground.
<b>SS</b>	Soft-Start	Soft-Start Time Setting. SS controls the soft-start period. Connect a capacitor from SS to GND to set the soft-start period. An internal current source (6 $\mu$ A) charges 0.1 $\mu$ F capacitor and sets the soft-start period to 13.5ms. If SS is floating, the SS charge current will decrease to 1/128 $\mu$ A and charge 30pF capacitor to set the soft-start period to 4ms.
<b>COMP</b>	Compensation Node	Compensation Node. COMP is used to compensate the regulation control loop. Connect a series RC network from COMP to GND. In some cases, an additional capacitor from COMP to GND is required.
<b>ROSC</b>	Frequency Setting	Switching Frequency Setting.
<b>RLIM</b>	Current Limit Setting	Current Limit Setting. Switch current limit threshold can be set by an external resistor. Current limit value is from 75mA to 2580mA. The value of 10k $\Omega$ $\leq$ R <sub>LIM</sub> $\leq$ 210k $\Omega$ is recommended.

Test point/ Pin name	Signal	Comment (expected waveforms or voltage levels on test points)
<b>EN_SW</b>	Enable Power Switch test pin	Enable Control Input for Power Switch.
<b>FAULT</b>	FAULT test point	Active-Low Open-Drain Output. Asserted during over current, over temperature, or reverse voltage conditions.
<b>SW_OUT</b>	Power Switch Output	Power Switch Output.
<b>SW_IN</b>	Power Switch Input	Power Switch Input. Supply voltage range is from 2.5V to 5.5V.
<b>FB</b>	Feedback Voltage	Feedback Voltage Input. This pin is connected to the converter output. It is used to set the output of the converter to regulate the desired value via an resistive divider.
<b>LX</b>	Switch Node test pin	Switch Node. Output of the internal high-side MOSFET. Connect this pin to external low-side N-MOSFET, inductor and bootstrap capacitor.
<b>BOOT</b>	BOOT Node test pin	Bootstrap Supply for High-Side Gate Driver. Connect a 1µF ceramic capacitor between the BOOT and LX pins.
<b>V5V</b>	V5V test pin	BG Driver Bias Supply. Decouple with a 1µF X5R/X7R ceramic capacitor between the V5V and GND pins.
<b>EN</b>	Enable test pin	Enable Control Input for Buck Converter. A logic-high enables the converter; a logic-low forces the device into shutdown mode.

### ***Power-up & Measurement Procedure***

1. Set the jumper at JP1 to connect terminals 1 and 2, connecting Vout to SW\_IN
2. Apply a 12V nominal input power supply to the VIN and GND terminals.
3. Connect an external load up to 6A to the VOUT and GND terminals and verify the output voltage and current.

### ***Output Voltage Setting***

Set the output voltage with the resistive divider (R1, R2) between External Input and GND with the midpoint connected to VREFIN. The output is set by the following formula :

$$V_{OUT} = V_{FB} \frac{R_2}{(R_1 + R_2)}$$



Reference	Qty	Part Number	Description	Package	Manufacture
GP6	1		Vout		
GP7	1		SW_OUT		
GP9	1		SW_IN_S		
GP10	1		SS		
GP14	1		SW		
GP15	1		V5V		
GP16	1		nFAULT		
GP17	1		BOOT		
GP11	1		RSOC		
GP12	1		RLIM		
GP13	1		ENSW		
JP1	1		SW_IN		
J1	1		Vin, GND		
L2	1	NR8040T4R7N	4.7 $\mu$ H		TAIYO YUDEN
R1	1	0603 40K2 1%	40.2k/0603	R-0603	
R2	1		7.68k/0603	R-0603	
R3	1		20k/0603	R-0603	
R4	1		53.6k/0603	R-0603	
R5	1		10k/0603	R-0603	
R6, R7, R8	3		100k/0603	R-0603	
U1	1	RT7249GQW	DC/DC Converter	WQFN-16L 4x4	RICHTEK
Z1, Z2, Z3, Z4	4		SIP-1P-M		
Z11, Z12, Z13, Z14	4		FK_1		

**PCB Layout**

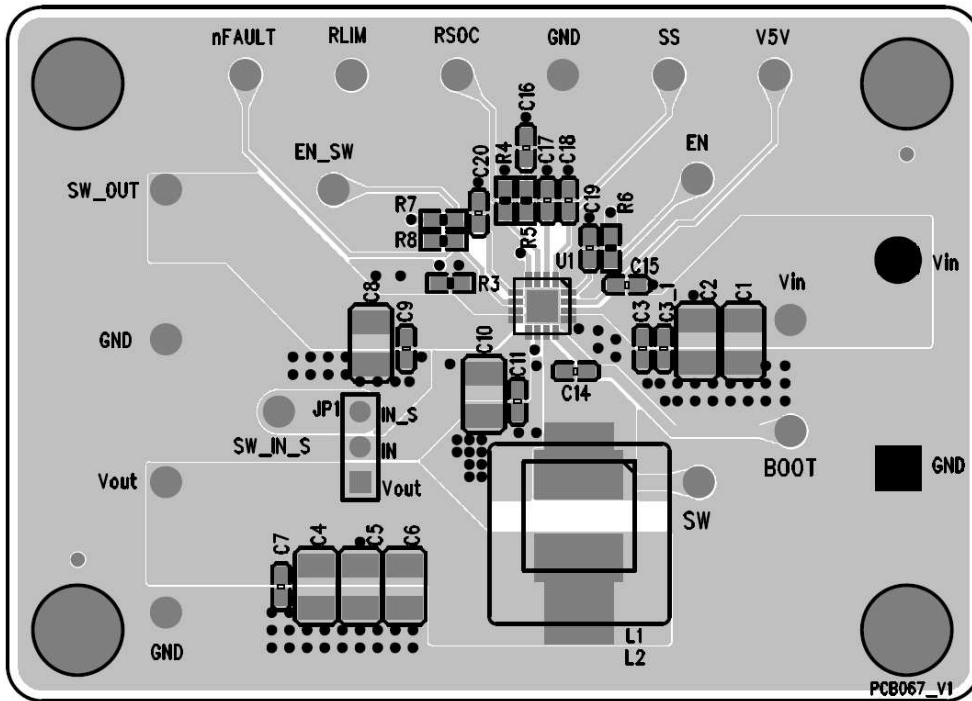

Top View (1<sup>st</sup> layer)

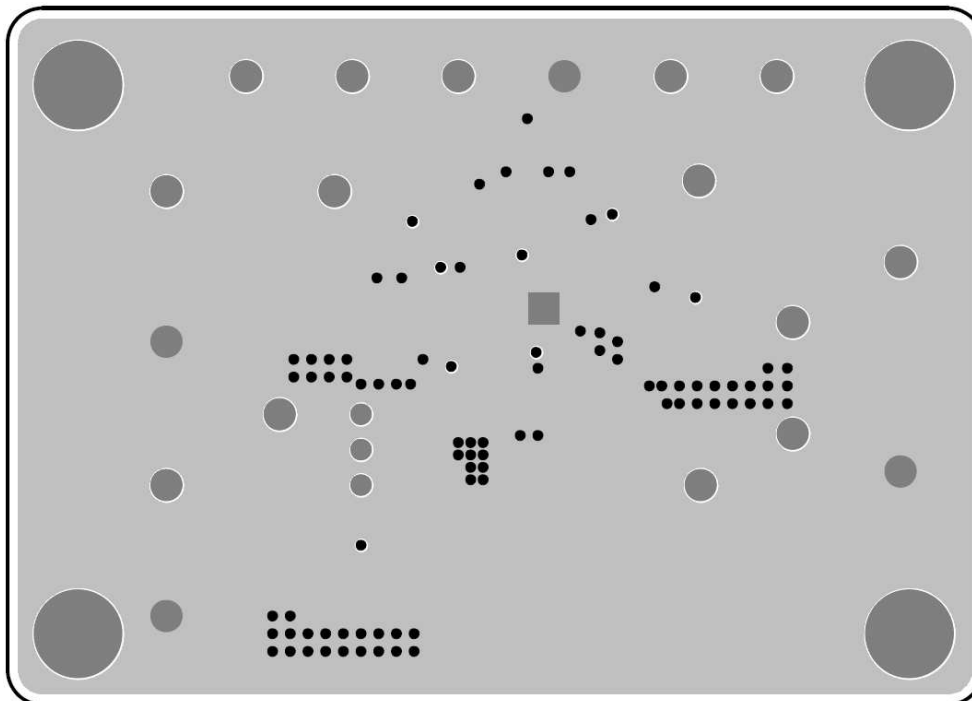

PCB Layout—Inner Side (2<sup>nd</sup> Layer)



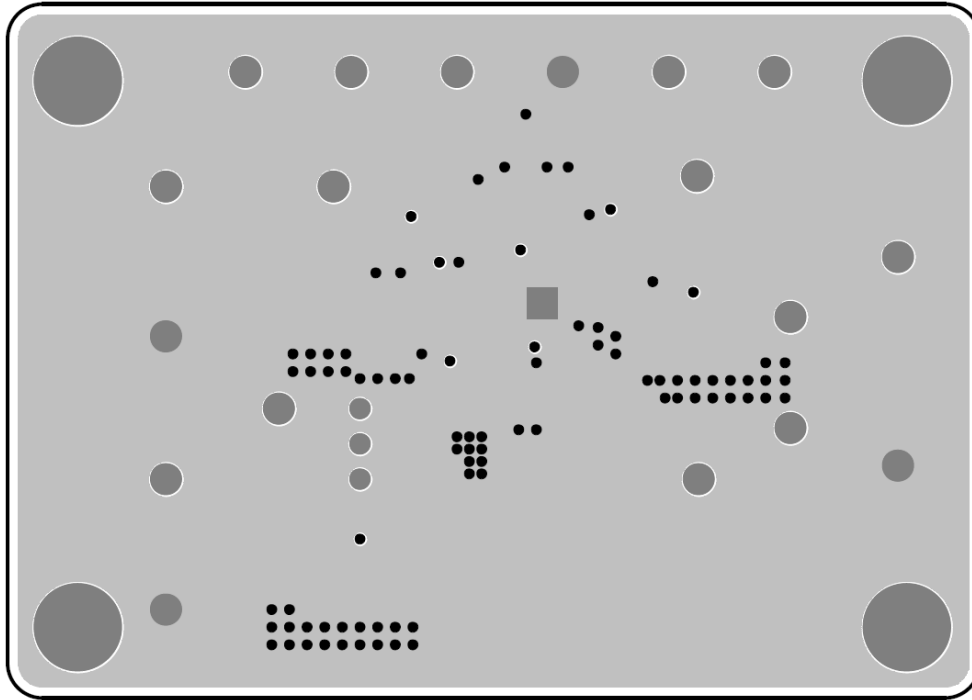

PCB Layout—Inner Side (3<sup>rd</sup> Layer)

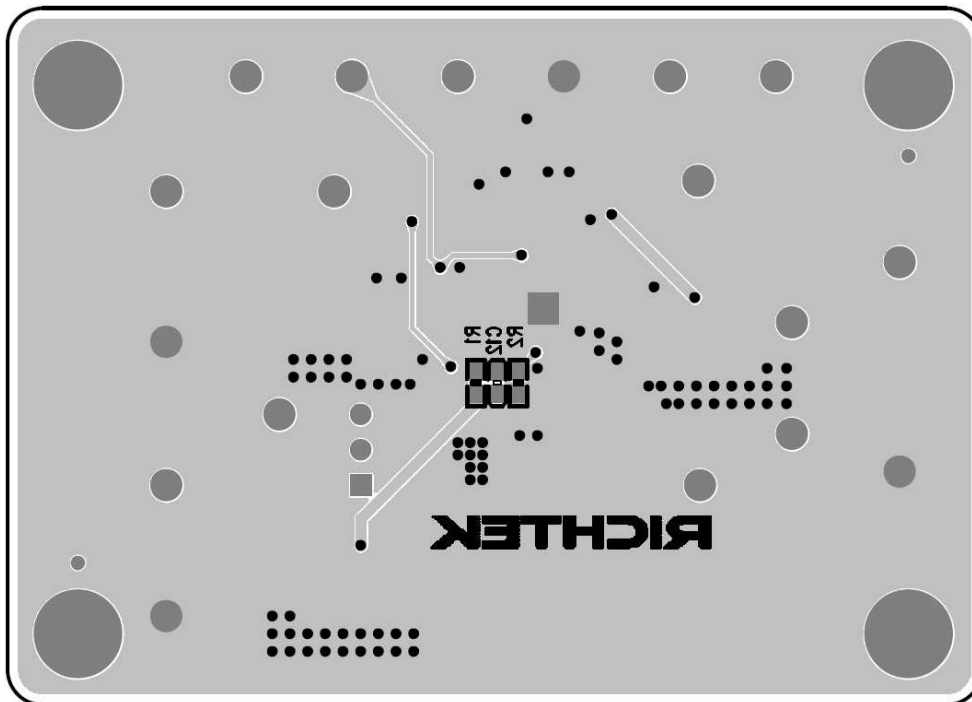

Bottom View (4<sup>th</sup> Layer)

### ***More Information***

For more information, please find the related datasheet or application notes from Richtek website <http://www.richtek.com>.

### ***Important Notice for Richtek Evaluation Board***

THIS DOCUMENT IS FOR REFERENCE ONLY, NOTHING CONTAINED IN THIS DOCUMENT SHALL BE CONSTRUED AS RICHTEK'S WARRANTY, EXPRESS OR IMPLIED, UNDER CONTRACT, TORT OR STATUTORY, WITH RESPECT TO THE PRESENTATION HEREIN. IN NO EVENT SHALL RICHTEK BE LIABLE TO BUYER OR USER FOR ANY AND ALL DAMAGES INCLUDING WITHOUT LIMITATION TO DIRECT, INDIRECT, SPECIAL, PUNITIVE OR CONSEQUENTIAL DAMAGES.