



Chipsmall Limited consists of a professional team with an average of over 10 year of expertise in the distribution of electronic components. Based in Hongkong, we have already established firm and mutual-benefit business relationships with customers from,Europe,America and south Asia,supplying obsolete and hard-to-find components to meet their specific needs.

With the principle of “Quality Parts,Customers Priority,Honest Operation,and Considerate Service”,our business mainly focus on the distribution of electronic components. Line cards we deal with include Microchip,ALPS,ROHM,Xilinx,Pulse,ON,Everlight and Freescale. Main products comprise IC,Modules,Potentiometer,IC Socket,Relay,Connector.Our parts cover such applications as commercial,industrial, and automotives areas.

We are looking forward to setting up business relationship with you and hope to provide you with the best service and solution. Let us make a better world for our industry!



Contact us

Tel: +86-755-8981 8866 Fax: +86-755-8427 6832

Email & Skype: info@chipsmall.com Web: www.chipsmall.com

Address: A1208, Overseas Decoration Building, #122 Zhenhua RD., Futian, Shenzhen, China



High Voltage High Current LED Driver Controller for Buck, Boost or Buck-Boost Topology

Purpose

The startup voltage of the RT8494 is around 4.5V. When VCC voltage is greater than 4.5V, the RT8494 starts operation and a regulated GBIAS supply voltage is generated by an internal LDO circuit. With VCC greater than 10V, the GBIAS supply will be regulated around 8.5V to supply the power for the internal GATE pin driver circuit.

Table of Contents

PURPOSE	1
INTRODUCTION	2
KEY PERFORMANCE SUMMARY TABLE	2
BENCH TEST SETUP CONDITIONS	3
SCHEMATIC, BILL OF MATERIALS & BOARD LAYOUT	5
MORE INFORMATION	8
IMPORTANT NOTICE FOR RICHTEK EVALUATION BOARD	8

Introduction

General Product Information

The RT8494 is a current mode PWM controller designed to drive an external MOSFET for high current LED applications. With a current sense amplifier threshold of 190mV, the LED current is programmable with one external current sense resistor. With the maximum operating input voltage of 36V and output voltage up to 90V, the RT8494 is ideal for Buck, Boost or Buck-Boost operation.

With the switching frequency programmable over 100kHz to 1MHz, the external inductor and capacitors can be small while maintaining high efficiency.

Dimming can be done by either analog or digital. The builtin clamping comparator and filter allow easy low noise analog dimming conversion from digital signal with only one external capacitor.

The RT8494 is available in SOP-14 package.

Product Feature

- **High Voltage Capability : V_{IN} up to 36V, LED Sensing Threshold Common Mode Voltage up to 90V**
- **Buck, Boost or Buck-Boost Operation**
- **Programmable Switching Frequency**
- **Easy Dimming Control : Analog or Digital Converting to Analog with One External Capacitor**
- **Programmable Soft-Start to Avoid Inrush Current**
- **Programmable Over-Voltage Protection**
- **V_{IN} Under-Voltage Lockout and Thermal Shutdown**
- **AEC-Q100 Compliance**

Key Performance Summary Table

Key Features	Evaluation Board Number : PCB042_V1
Input Voltage Range	4.5V to 36V
Input Threshold (VISP - VISN)	190mV
Threshold Common Mode Voltage	90V
Default Marking & Package Type	RT8494GS, SOP-14
Switching Frequency	Programmable Switching Frequency

Bench Test Setup Conditions

Headers Description and Placement

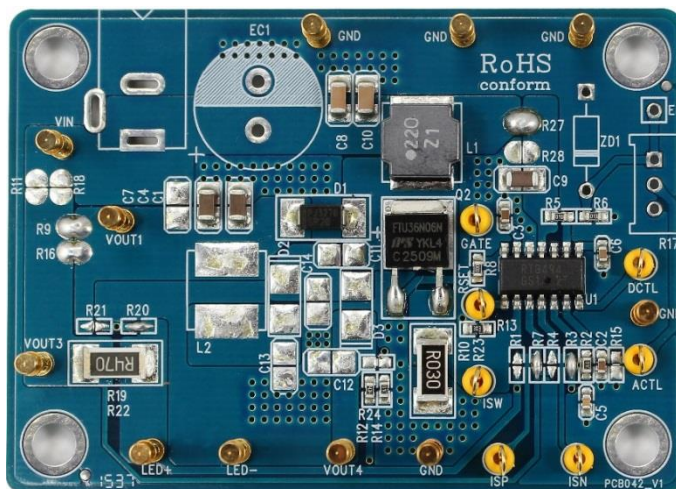

Please carefully inspect the EVB IC and external components, comparing them to the following Bill of Materials, to ensure that all components are installed and undamaged. If any components are missing or damaged during transportation, please contact the distributor or send e-mail to evb_service@richtek.com

Test Points

The EVB is provided with the test points and pin names listed in the table below.

Test point/ Pin name	Signal	Comment (expected waveforms or voltage levels on test points)
RSET	Switch Frequency Setting	Switch Frequency Setting. Connect a resistor from RSET to GND. $RRSET = 30k\Omega$ will set $f_{sw} = 350kHz$.
ISW	Switch Current Sense	External MOSFET Switch Current Sense. Connect the current sense resistor between external N-MOSFET switch and the ground.
ISP	LED Current Sense	LED Current Sense Amplifier Positive Input with Common Mode up to 90V.
ISN	LED Current Sense	LED Current Sense Amplifier Negative Input. Voltage threshold between ISP and ISN is 190mV with common mode voltage up to 90V.
VC	Compensation	PWM Control Loop Compensation.
ACTL	Analog Dimming Control	Analog Dimming Control. The effective programming voltage range of the pin is between 0.2V and 1.2V.
DCTL	PWM dimming	By adding a $0.47\mu F$ filtering capacitor on ACTL pin, the PWM dimming signal on DCTL pin can be averaged and converted into analog dimming signal on the ACTL pin.
SS	Soft-Start	Soft-Start Time Setting. A capacitor of at least 10nF is required for proper soft-start.
EN	Enable Control	Enable Control Input (Active High). When this pin voltage is low, the chip is in shutdown mode.
OVP	Over-Voltage	Over-Voltage Protection. The PWM converter turns off when the voltage of the pin goes to higher than 1.18V.
VCC	Internal Driver voltage	Power Supply of the Chip. For good bypass, a low ESR capacitor is required.

Test point/ Pin name	Signal	Comment (expected waveforms or voltage levels on test points)
GND	Ground	Ground. The Exposed Pad must be Soldered to a Large PCB and Connected to GND for Maximum Power Dissipation.
GBIAS	Gate Driver Bias	Internal Gate Driver Bias. A good bypass capacitor is required.
GATE	Switch Gate Driver	External MOSFET Switch Gate Driver Output.

Power-up & Measurement Procedure

1. Connect input power ($4.5V < V_{IN} < 36V$) to VIN test pin.
2. ACTL to 2V, see SW switch is working.
3. Observe the output voltage and output current is correct.

Output Over-Voltage Setting

The RT8494 is equipped with an Over-Voltage Protection (OVP) function. When the voltage at OVP pin exceeds a threshold of approximately 1.18V, the power switch is turned off. The power switch can be turned on again once the voltage at OVP pin drops below 1.18V. For the Boost and Buck-Boost application, the output voltage could be clamped at a certain voltage level. The OVP voltage can be set by the following equation :

$$V_{OUT, OVP} = 1.18 \times \left(1 + \frac{R1}{R2} \right)$$

LED Current Setting

The LED current is programmed by placing an appropriate value current sense resistor between the ISP and ISN pins. Typically, sensing of the current should be done at the top of the LED string. The ACTL pin should be tied to a voltage higher than 1.2V to get the full-scale 190mV (typical) threshold across the sense resistor. The ACTL pin can also be used to dim the LED current to zero, although relative accuracy decreases with the decreasing voltage sense threshold. When the ACTL pin voltage is less than 1.2V, the LED current is :

$$I_{LED} = \frac{(V_{ACTL} - 0.2) \times 0.19}{R_{SENSE}}$$

Schematic, Bill of Materials & Board Layout

EVB Schematic Diagram

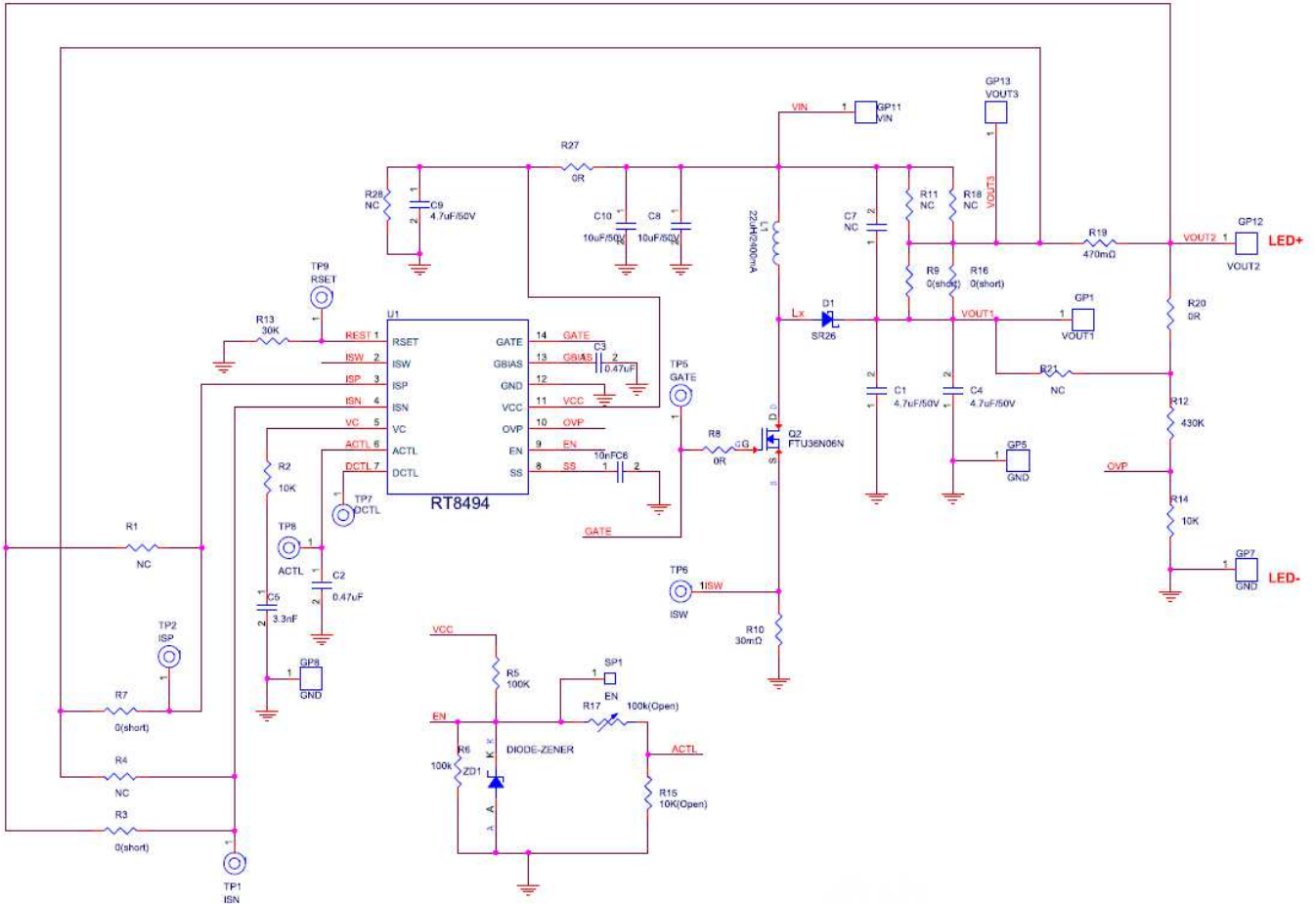

Bill of Materials

Reference	Qty	Part Number	Description	Package	Manufacture
U1	1	RT8494GS	LED Driver Controller	SOP-14	RICHTEK
C1, C4	2	0603B472K500	4.7 μ F/50V	C-1210/2.159	WALSIN
C2, C3	2	C1608X7R1C474K	0.47 μ F	C0603	TDK
C5	1	C1608COG1H332J	3.3nF	C0603	TDK
C6	1	0603B103K500	10nF	C0603	WALSIN
C8, C10	2	C3225Y5V1H106Z	10 μ F/50V	C-1210/3.048	TDK
C9	1	0603B472K500	4.7 μ F/50V	C-1210/2.159	WALSIN
D1	1		SR26, 2A, 60V	SMC	PANJIT
VOUT1, GND, VIN, VOUT2,	6		GP	SIP-1P-GP	
L1	1		22 μ H	L-SH8018	美磊/乾坤
Q2	1		FTU36N06N	TO-252-123	營格
R19	1		470m Ω	RC-1A	Viking
R10	1		30m Ω	RC-1A	Viking
R13	1	WR06X3002F	30k	R0603	WALSIN
R2, R14	2	WR06X1002F	10k	R0603	WALSIN
R12	1	WR06X4303F	430k	R0603	WALSIN
R5,R6	2	WR06X1003F	100k	R0603	WALSIN
R3, R7, R9, R16, R27	5		0 (short)		

PCB Layout

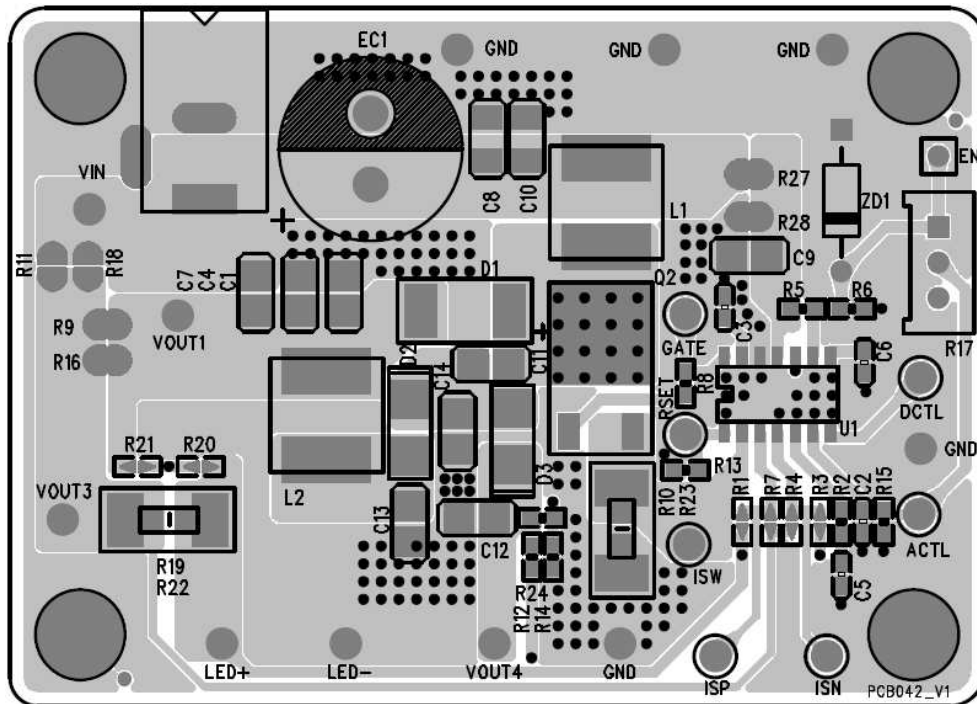

Top View

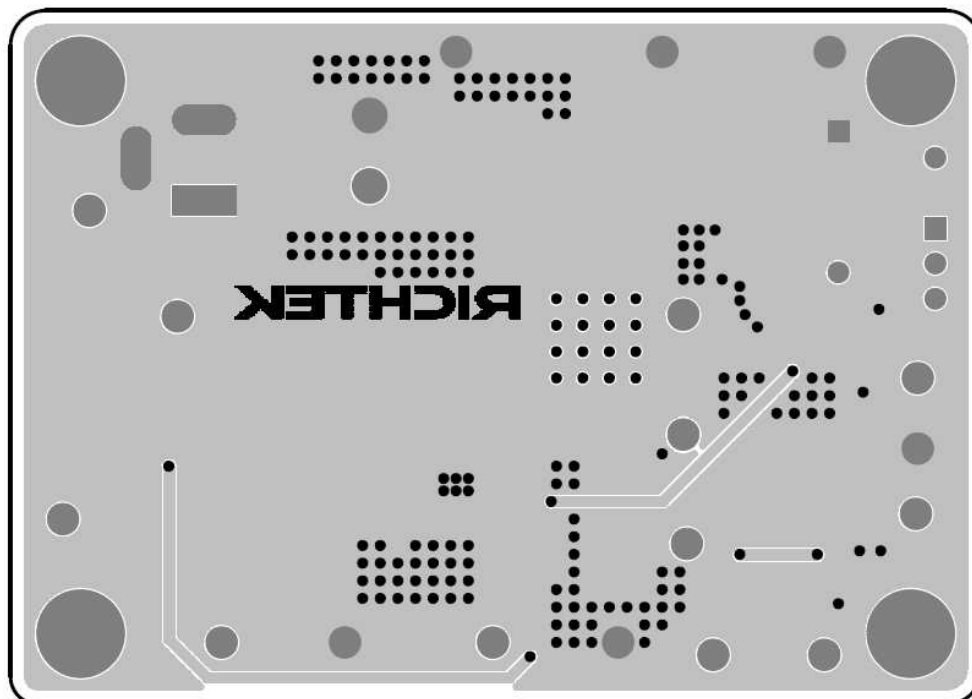

Bottom View

More Information

For more information, please find the related datasheet or application notes from Richtek website <http://www.richtek.com>.

Important Notice for Richtek Evaluation Board

THIS DOCUMENT IS FOR REFERENCE ONLY, NOTHING CONTAINED IN THIS DOCUMENT SHALL BE CONSTRUED AS RICHTEK'S WARRANTY, EXPRESS OR IMPLIED, UNDER CONTRACT, TORT OR STATUTORY, WITH RESPECT TO THE PRESENTATION HEREIN. IN NO EVENT SHALL RICHTEK BE LIABLE TO BUYER OR USER FOR ANY AND ALL DAMAGES INCLUDING WITHOUT LIMITATION TO DIRECT, INDIRECT, SPECIAL, PUNITIVE OR CONSEQUENTIAL DAMAGES.