



Chipsmall Limited consists of a professional team with an average of over 10 year of expertise in the distribution of electronic components. Based in Hongkong, we have already established firm and mutual-benefit business relationships with customers from,Europe,America and south Asia,supplying obsolete and hard-to-find components to meet their specific needs.

With the principle of "Quality Parts,Customers Priority,Honest Operation,and Considerate Service",our business mainly focus on the distribution of electronic components. Line cards we deal with include Microchip,ALPS,ROHM,Xilinx,Pulse,ON,Everlight and Freescale. Main products comprise IC,Modules,Potentiometer,IC Socket,Relay,Connector.Our parts cover such applications as commercial,industrial, and automotives areas.

We are looking forward to setting up business relationship with you and hope to provide you with the best service and solution. Let us make a better world for our industry!



Contact us

Tel: +86-755-8981 8866 Fax: +86-755-8427 6832

Email & Skype: info@chipsmall.com Web: www.chipsmall.com

Address: A1208, Overseas Decoration Building, #122 Zhenhua RD., Futian, Shenzhen, China



300mA Dual LDO Regulator

Purpose

The RT9055 is a dual channel, low noise, and low drop Regulator sourcing up to 300mA at each channel. Its input voltage range is from 1.5V to 5.5V and provides an adjustable regulated output voltage from 0.9V to 3.5V while delivering up to 0.3A of output current. This document explains the function and use of the RT9055 evaluation board (EVB), and provides information to enable operation, modification of the evaluation board and circuit to suit individual requirements.

Table of Contents

Purpose	1
Introduction.....	2
Key Performance Summary Table	2
Bench Test Setup Conditions	3
Schematic, Bill of Materials & Board Layout	4
More Information.....	6
Important Notice for Richtek Evaluation Board	6

Introduction

General Product Information

The RT9055 is a dual channel, low noise, and low drop Regulator sourcing up to 300mA at each channel. The input voltage range is from 1.5V to 5.5V.

The RT9055 offers 2% accuracy, extremely low dropout voltage and extremely low quiescent current (only 29µA per LDO). The shutdown current is near zero which is suitable for battery powered applications. The RT9055 also provides protection function such as current limiting, output short circuit protection, and over temperature protection.

Product Feature

- Wide Operating Voltage Range : 1.5V to 5.5V
- Low Noise for RF Application
- No Noise Bypass Capacitor Required
- Fast Response in Line/Load Transient
- TTL Logic Controlled Shutdown Input
- Low Temperature Coefficient
- Dual LDO Outputs (300mA/300mA)
- Ultra-Low Quiescent Current : 29µA/LDO
- High Output Accuracy 2%
- Short Circuit Thermal Folded Back Protection
- Thermal Shutdown Protection
- Current Limit Protection
- RoHS Compliant and Halogen Free

Key Performance Summary Table

Key Features	Evaluation Board Number : PCB044_V1
Default Output Voltage	0.9V to 3.5V
Max Output Current (Dual LDO Outputs)	300mA/300mA
Ultra-Low Quiescent Current (Single LDO)	29µA
Default Marking & Package Type	RT9055-NGWSC, WL-CSP-6B 0.8x1.2

Bench Test Setup Conditions

Headers Description and Placement

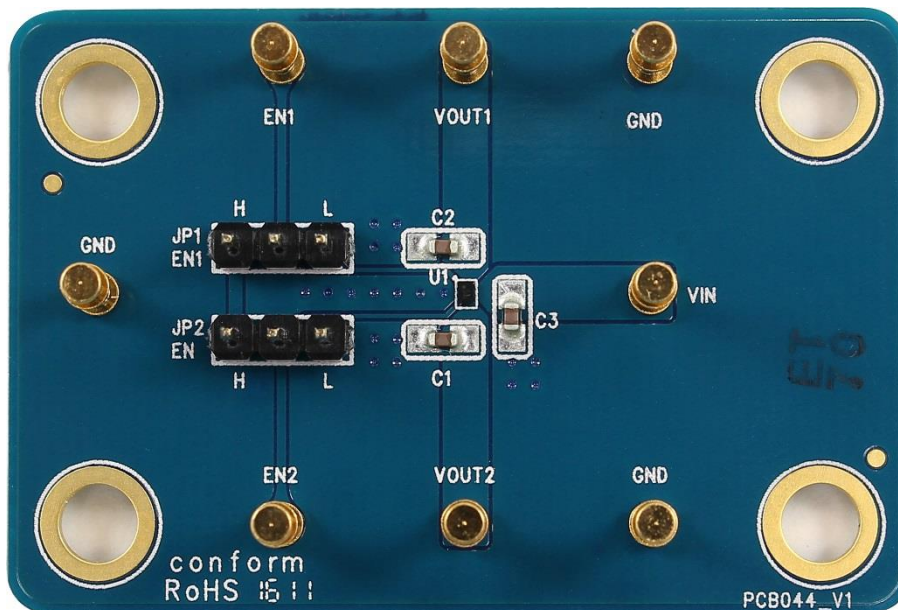

Please carefully inspect the EVB IC and external components, comparing them to the following Bill of Materials, to ensure that all components are installed and undamaged. If any components are missing or damaged during transportation, please contact the distributor or send e-mail to evb_service@richtek.com.

Test Points

The EVB is provided with the test points and pin names listed in the table below.

Test point/ Pin name	Signal	Comment (expected waveforms or voltage levels on test points)
EN1	Enable point	LDO1 Enable (Active High).
VOUT1	Output pin	LDO1 Output Voltage.
GND	Ground	Ground.
VIN	Input voltage	Power Supply Input.
EN2	Enable point	LDO2 Enable (Active High).
VOUT2	Output pin	LDO2 Output Voltage.

Power-up & Measurement Procedure

1. Connect input power ($1.5V < V_{IN} < 5.5V$) and input ground to VIN and GND test pins respectively.
2. To use a jumper at "H" option to tie EN test pin for enabling the device. Inversely, to use a jumper at "L" option to tie EN test pin and ground GND for disabling the device.
3. Connect an external load up to 0.3A to the VOUT and GND terminals and verify the output voltage.

Schematic, Bill of Materials & Board Layout

EVB Schematic Diagram

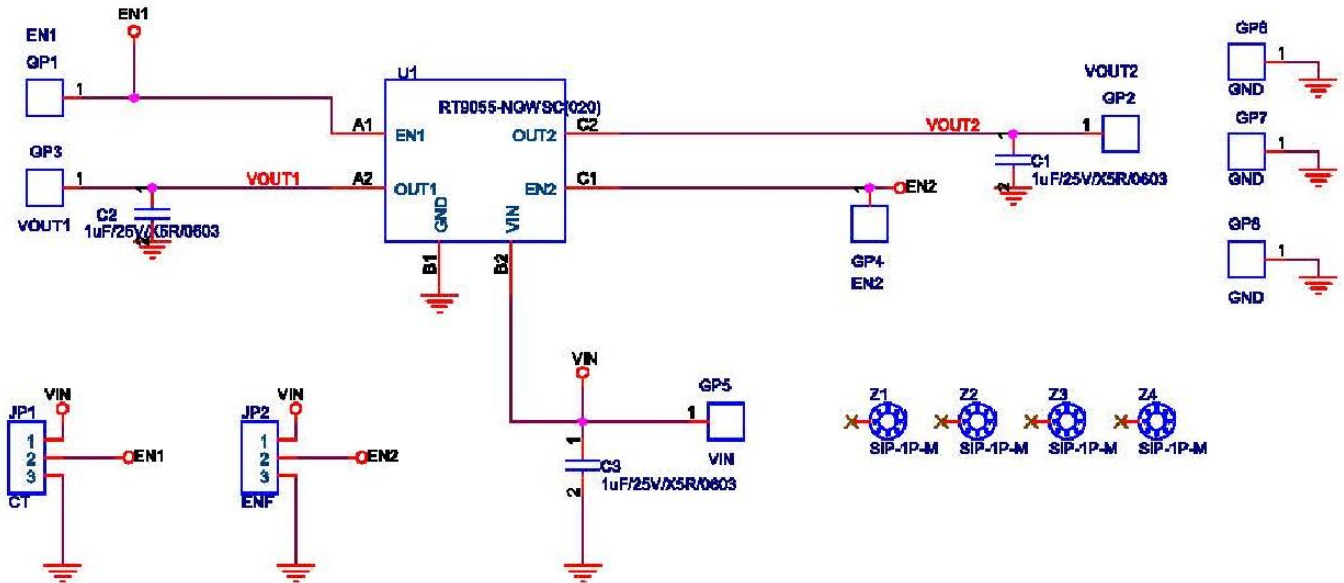

Bill of Materials

Reference	Qty	Part Number	Description	Package	Manufacture
U1	1	RT9055-NGWSC	Linear Regulator	WL-CSP-6B 0.8x1.2	RICHTEK
C1, C2, C3	3	C0603X5R	1 μ F/25V	C-0603	TDK
JP1, JP2	2		Jumper		
GP1, GP2, GP3, GP4, GP5, GP6, GP7, GP8	8		Golden Pin		
Z1, Z2, Z3, Z4	4		SIP-1P-M	SIP-1P-M	

PCB Layout

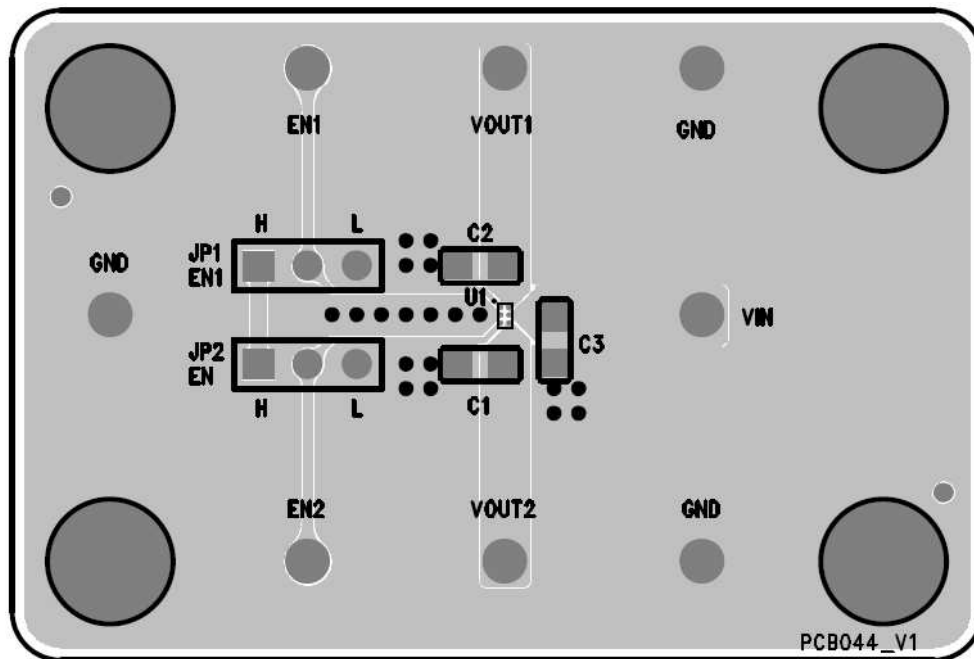

Top View

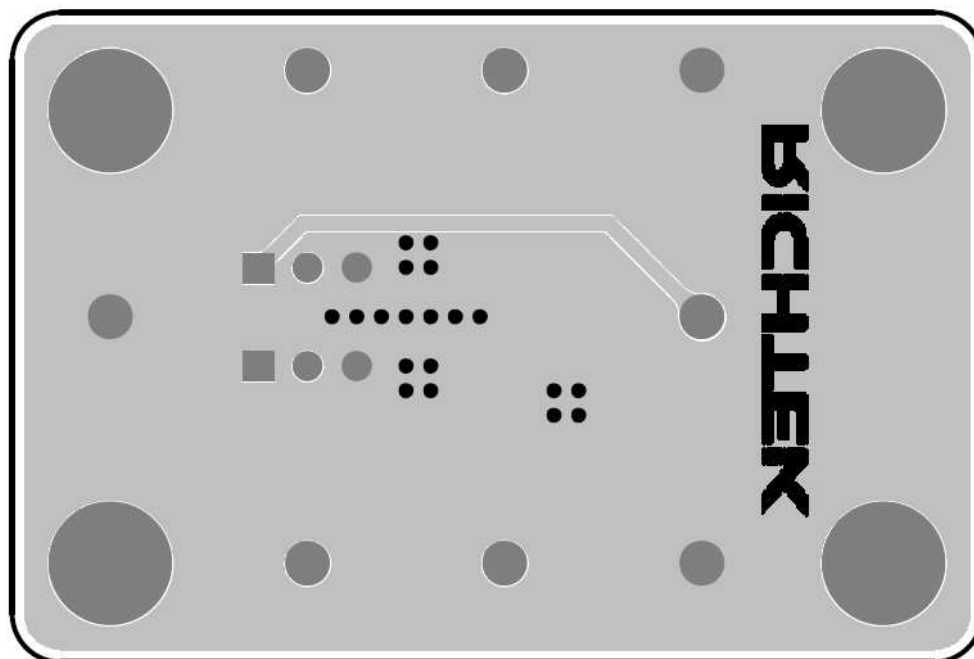

Bottom View

More Information

For more information, please find the related datasheet or application notes from Richtek website <http://www.richtek.com>.

Important Notice for Richtek Evaluation Board

THIS DOCUMENT IS FOR REFERENCE ONLY, NOTHING CONTAINED IN THIS DOCUMENT SHALL BE CONSTRUED AS RICHTEK'S WARRANTY, EXPRESS OR IMPLIED, UNDER CONTRACT, TORT OR STATUTORY, WITH RESPECT TO THE PRESENTATION HEREIN. IN NO EVENT SHALL RICHTEK BE LIABLE TO BUYER OR USER FOR ANY AND ALL DAMAGES INCLUDING WITHOUT LIMITATION TO DIRECT, INDIRECT, SPECIAL, PUNITIVE OR CONSEQUENTIAL DAMAGES.