



Chipsmall Limited consists of a professional team with an average of over 10 year of expertise in the distribution of electronic components. Based in Hongkong, we have already established firm and mutual-benefit business relationships with customers from,Europe,America and south Asia,supplying obsolete and hard-to-find components to meet their specific needs.

With the principle of “Quality Parts,Customers Priority,Honest Operation,and Considerate Service”,our business mainly focus on the distribution of electronic components. Line cards we deal with include Microchip,ALPS,ROHM,Xilinx,Pulse,ON,Everlight and Freescale. Main products comprise IC,Modules,Potentiometer,IC Socket,Relay,Connector.Our parts cover such applications as commercial,industrial, and automotives areas.

We are looking forward to setting up business relationship with you and hope to provide you with the best service and solution. Let us make a better world for our industry!



Contact us

Tel: +86-755-8981 8866 Fax: +86-755-8427 6832

Email & Skype: info@chipsmall.com Web: www.chipsmall.com

Address: A1208, Overseas Decoration Building, #122 Zhenhua RD., Futian, Shenzhen, China



RT9746 VBUS OVP with a PTVS Diode

Purpose

The RT9746 is a VBUS OVP protector switch. This document explains the function and use of the RT9746 evaluation board (EVB), and provides information to enable operation, output voltage setting of the evaluation board.

Table of Contents

Purpose.....	1
Introduction	2
Bench Test Setup Conditions.....	3
Schematic, Bill of Materials & Board Layout.....	4
More Information.....	6
Important Notice for Richtek Evaluation Board.....	6

Introduction

General Product Information

The RT9746 is an overvoltage protection devices feature a low 35mΩ (typ) RON internal FET with PTVS diode. The PTVS also protects the devices from surges up to 100V. When the input voltage exceeds the overvoltage threshold, the internal FET is turned off to prevent damage to the protected down stream components. The internal Over Voltage Thresholds (OVP) are preset to 6.8V typical. The RT9746 also feature an over-current protection and up to 4.5A. The RT9746 is offered in a small WL-CSP-12B (BSC) package provides small PCB area applications.

Product Feature

- **PTVS Diode Embedded for VBUS Surge Protection**
- **Warning Indicator for OVP or UVP**
- **28V Maximum Rating for DC Adapt**
- **Integrated Over-Voltage and Over Current Protection FET on VBUS for Fault Isolation**

Key Performance Summary Table

Key Features	Evaluation Board Number: PCB083_V1
Default Input Voltage	5V
Max Output Over Current	4.5A
Default Marking & Package Type	RT9746WSC, WL-CSP-12B 1.92x1.27 (BSC)

Bench Test Setup Conditions

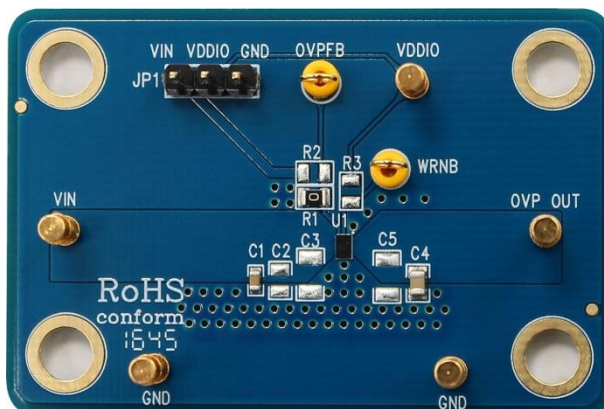

Carefully inspect all the components used in the EVB according to the following Bill of Materials table, and then make sure all the components are undamaged and correctly installed. If there is any missing or damaged component, which may occur during transportation, please contact our distributors or e-mail us at evb_service@richtek.com.

Test Points

The EVB is provided with the test points and pin names listed in the table below.

Test point/ Pin name	Signal	Comment (expected waveforms or voltage levels on test points)
VIN	Input voltage	VBUS from Power Adaptor.
OVP OUT	Output voltage	Output from VBUS Load-Switch.
OVPFB	External OVP Adjustment Setting	If no used, be surely tied to GND.
GND	Ground	Ground.
WRNB	Inverse Warning Signal	OCP,OTP, OVP, UVLO Flag Output (Open-Drain)

Power-up

The RT9746 has a threshold of 2.7V power on reset (POR) with a built-in hysteresis of 100mV. Before the input voltage reaches the POR threshold, the RT9746 is off. When the input voltage is over the POR threshold, the VOUT of RT9746 will delay for 32ms which includes soft-start time of 8ms.

Input Over-Voltage Protection

The RT9746 provides input over-voltage protection via internal or external resistor to set OVP level.

- If OVPFB is connected to GND, the RT9746 uses the internal OVP level setting.
- If an external resistor-divider is connected to OVPFB and VOVPFB exceeds the VOVP_SEL voltage, the RT9746 will adopt external OVP level setting. The OVP level VOVP is set as below.

$$V_{OVP} = V_{REF_EXT} \times \left(1 + \frac{R2}{R1}\right)$$

Schematic, Bill of Materials & Board Layout

EVB Schematic Diagram

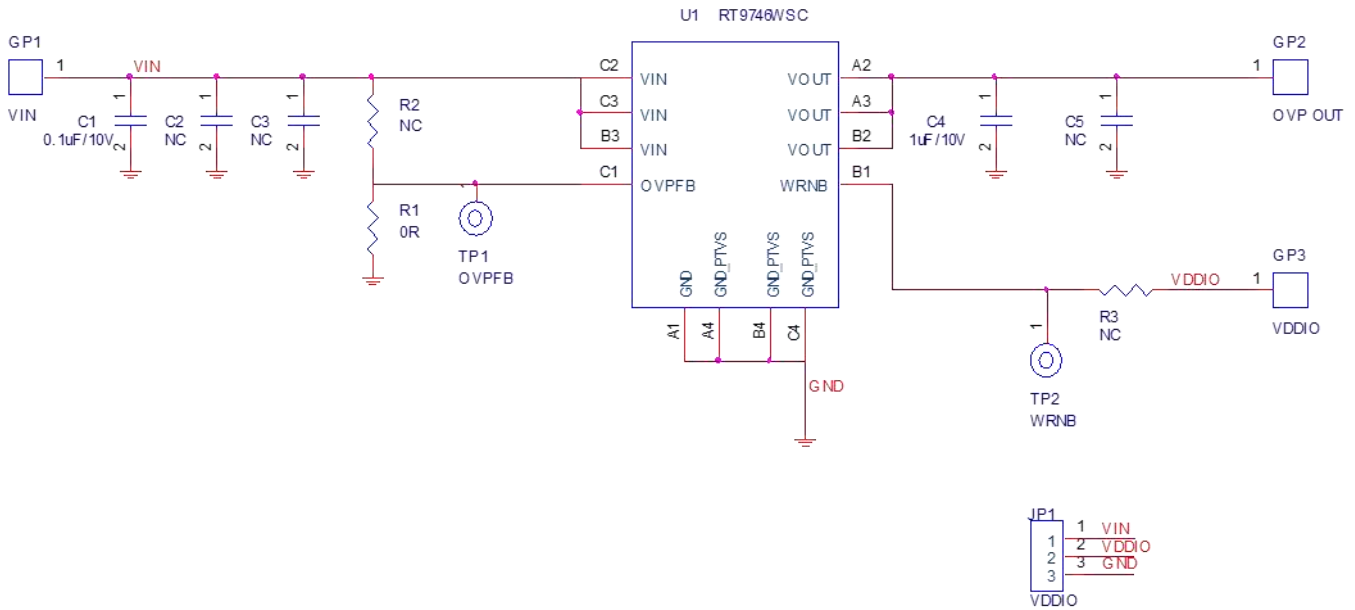

Bill of Materials

Reference	Qty	Part number	Description	Package	Manufacturer
U1	1	RT9746WSC	VBUS OVP IC with PTVS Diode	WL-CSP-12B 1.92x1.27(BSC)	RICHTEK
C1	1	C1608X7R1H104K080AA	0.1μF/50V/X7R/0603	C-0603	TDK
C4	1	C2012X7R1E105KT	1μF/25V/X7R/0805	C-0805	TDK
R1	1	0805T-5-0R	0R/0805	R-0805	RALEC

PCB Layout

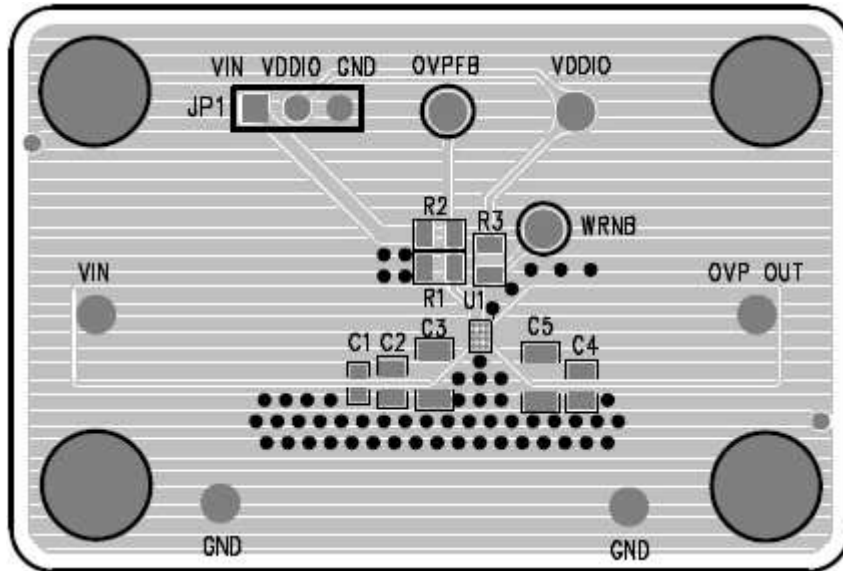

Top View

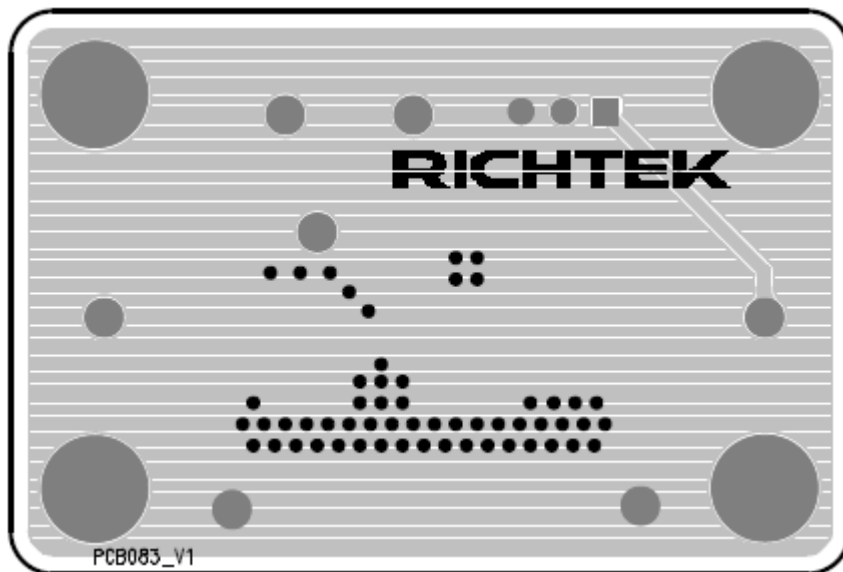

Bottom View

More Information

For more information, please find the related datasheet or application notes from Richtek website <http://www.richtek.com>.

Important Notice for Richtek Evaluation Board

THIS DOCUMENT IS FOR REFERENCE ONLY, NOTHING CONTAINED IN THIS DOCUMENT SHALL BE CONSTRUED AS RICHTEK'S WARRANTY, EXPRESS OR IMPLIED, UNDER CONTRACT, TORT OR STATUTORY, WITH RESPECT TO THE PRESENTATION HEREIN. IN NO EVENT SHALL RICHTEK BE LIABLE TO BUYER OR USER FOR ANY AND ALL DAMAGES INCLUDING WITHOUT LIMITATION TO DIRECT, INDIRECT, SPECIAL, PUNITIVE OR CONSEQUENTIAL DAMAGES.