



Chipsmall Limited consists of a professional team with an average of over 10 year of expertise in the distribution of electronic components. Based in Hongkong, we have already established firm and mutual-benefit business relationships with customers from,Europe,America and south Asia,supplying obsolete and hard-to-find components to meet their specific needs.

With the principle of “Quality Parts,Customers Priority,Honest Operation,and Considerate Service”,our business mainly focus on the distribution of electronic components. Line cards we deal with include Microchip,ALPS,ROHM,Xilinx,Pulse,ON,Everlight and Freescale. Main products comprise IC,Modules,Potentiometer,IC Socket,Relay,Connector.Our parts cover such applications as commercial,industrial, and automotives areas.

We are looking forward to setting up business relationship with you and hope to provide you with the best service and solution. Let us make a better world for our industry!



Contact us

Tel: +86-755-8981 8866 Fax: +86-755-8427 6832

Email & Skype: info@chipsmall.com Web: www.chipsmall.com

Address: A1208, Overseas Decoration Building, #122 Zhenhua RD., Futian, Shenzhen, China



Features

- Single superhet architecture for low external component count
- FSK for digital data and FM reception for analog signal transmission
- FSK/FM demodulation with phase-coincidence demodulator
- Low current consumption in active mode and very low standby current
- Switchable LNA gain for improved dynamic range
- RSSI allows signal strength indication and ASK detection
- Surface mount package LQFP32

Ordering Information

Part No.

EVB711111-868-FSK
EVB711111-868-ASK

EVB711111-915-FSK
EVB711111-915-ASK

Application Examples

- General digital and analog 868 MHz or 915 MHz ISM band usage
- Low-power telemetry
- Alarm and security systems
- Remote Keyless Entry (RKE)
- Tire Pressure Monitoring System (TPMS)
- Garage door openers
- Home automation
- Pagers

Evaluation Board



General Description

The TH711111 FSK/FM/ASK single-conversion superheterodyne receiver IC is designed for applications in the European 868 MHz industrial-scientific-medical (ISM) band, according to the EN 300 220 telecommunications standard. It can also be used for any other system with carrier frequencies ranging from 800 MHz to 930 MHz (e.g. for applications in the US 915 MHz ISM band).

Document Content

1	Theory of Operation	3
1.1	General	3
1.2	Technical Data Overview	3
1.3	Block Diagram	4
1.4	Mode Configurations	4
1.5	LNA GAIN Control	4
1.6	Frequency Planning	5
1.6.1	Selected Frequency Plans	5
2	FSK Application Circuits	6
2.1	PCB Top View for FSK Reception	7
2.2	Board Component Values for FSK (Fig. 2)	8
3	ASK Application Circuits	9
3.1	PCB Top View for ASK Reception	10
3.2	Board Component Values for ASK (Fig. 3)	11
4	Package Dimensions	12
5	Reliability Information	13
6	ESD Precautions	13
7	Disclaimer	14

1 Theory of Operation

1.1 General

With the TH71111 receiver chip, various circuit configurations can be arranged in order to meet a number of different customer requirements. For FM/FSK reception the IF tank used in the phase coincidence demodulator can be constituted either by a ceramic resonator or an LC tank (optionally with a varactor diode to create an AFC circuit). In ASK configuration, the RSSI signal is feed to an ASK detector, which is constituted by the operational amplifier.

Demodulation	Type of receiver
FSK / FM	narrow-band RX with ceramic demodulation tank
FSK / FM	wide-band RX with LC demodulation tank
ASK	RX with RSSI-based demodulation

A double-conversion variant, called TH71112, is also available. This receiver IC allows a higher degree of image rejection, achieved in conjunction with an RF front-end filter. Both RXICs have the same die. At the TH71112, the second mixer (MIX2) is used to down-convert the first IF (IF1) to the second IF (IF2). At the TH71111, MIX2 operates as an amplifier.

Efficient RF front-end filtering is realized by using a SAW, ceramic or helix filter in front of the LNA and by adding an LC filter at the LNA output.

The TH71111 receiver IC consists of the following building blocks:

- PLL synthesizer (PLL SYNTH) for generation of the local oscillator signal LO
- Parts of the PLL SYNTH are the high-frequency VCO1, the feedback divider DIV_32, a phase-frequency detector (PFD) with charge pump (CP) and a crystal-based reference oscillator (RO)
- Low-noise amplifier (LNA) for high-sensitivity RF signal reception
- First mixer (MIX1) for down-conversion of the RF signal to the IF
- IF pre amplifier which is a mixer cell (MIX2) that operates as an amplifier
- IF amplifier (IFA) to amplify and limit the IF signal and for RSSI generation
- Phase coincidence demodulator (DEMOD) with third mixer (MIX3) to demodulate the IF signal
- Operational amplifier (OA) for data slicing, filtering and ASK detection
- Bias circuitry for bandgap biasing and circuit shutdown

1.2 Technical Data Overview

- | | |
|---|---|
| <ul style="list-style-type: none"> <input type="checkbox"/> Input frequency range: 800 MHz to 930 MHz <input type="checkbox"/> Power supply range: 2.3 V to 5.5 V @ ASK <input type="checkbox"/> Temperature range: -40 °C to +85 °C <input type="checkbox"/> Standby current: 50 nA <input type="checkbox"/> Operating current: 7.5 mA at low gain mode
9.2 mA at high gain mode <input type="checkbox"/> Sensitivity: -109 dBm ¹⁾ with 40 kHz IF filter BW <input type="checkbox"/> Sensitivity: -102 dBm ²⁾ with 150 kHz IF filter BW <input type="checkbox"/> Range of IF: 400 kHz to 22 MHz <input type="checkbox"/> Maximum data rate: 80 kbit/s NRZ | <ul style="list-style-type: none"> <input type="checkbox"/> Maximum input level: -10 dBm at ASK
0 dBm at FSK <input type="checkbox"/> Image rejection: > 55 dB (e.g. with SAW front-end filter and at 10.7 MHz IF) <input type="checkbox"/> Spurious emission: < -70 dBm <input type="checkbox"/> Input frequency acceptance: ±50 kHz (with AFC option) <input type="checkbox"/> RSSI range: 70 dB <input type="checkbox"/> Frequency deviation range: ±4 kHz to ±120 kHz <input type="checkbox"/> Maximum analog modulation frequency: 15 kHz |
|---|---|

- 1) at ± 8 kHz FSK deviation, BER = 3·10⁻³, phase-coincidence demodulation and SAW front-end filter loss
 2) at ± 50 kHz FSK deviation, BER = 3·10⁻³, phase-coincidence demodulation and SAW front-end filter loss

For more detailed information, please refer to the latest TH71111 data sheet revision.

1.3 Block Diagram

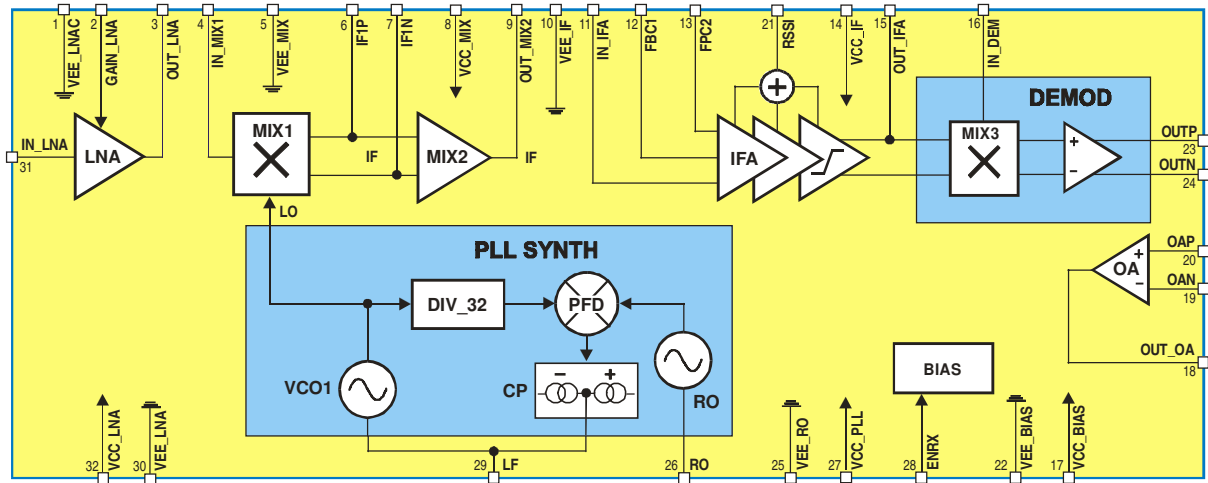

Fig. 1: TH71111 block diagram

1.4 Mode Configurations

ENRX	Mode	Description
0	RX standby	RX disabled
1	RX active	RX enable

Note: ENRX are pulled down internally

1.5 LNA GAIN Control

V _{GAIN_LNA}	Mode	Description
< 0.8 V	HIGH GAIN	LNA set to high gain
> 1.4 V	LOW GAIN	LNA set to low gain

Note: hysteresis between gain modes to ensure stability

1.6 Frequency Planning

Frequency planning is straightforward for single-conversion applications because there is only one IF that might be chosen, and then the only possible choice is low-side or high-side injection of the LO signal (which is now the one and only LO signal in the receiver).

The receiver's single-conversion architecture requires careful frequency planning. Besides the desired RF input signal, there are a number of spurious signals that may cause an undesired response at the output. Among them is the image of the RF signal that must be suppressed by the RF front-end filter.

By using the internal PLL synthesizer of the TH71111 with the fixed feedback divider ratio of $N = 32$ (DIV_32), two types of down-conversion are possible: low-side injection of LO and high-side injection of LO. The following table summarizes some equations that are useful to calculate the crystal reference frequency (REF), the IF and the LO frequency respectively, for a given RF.

Injection type	low	high
REF	$(RF - IF)/32$	$(RF + IF)/32$
LO	$32 \cdot REF$	$32 \cdot REF$
IF	$RF - LO$	$LO - RF$
RF image	$RF - 2IF$	$RF + 2IF$

1.6.1 Selected Frequency Plans

The following table depicts crystal, LO and image signals considering the examples of 868.3 MHz and 915 MHz RF reception at IF = 10.7 MHz.

Signal type	RF = 868.3 MHz	RF = 868.3 MHz	RF = 915 MHz	RF = 915 MHz
Injection type	low	high	low	high
REF / MHz	26.80000	27.46875	28.25938	28.92813
LO / MHz	857.6	879.0	904.3	925.7
RF image / MHz	846.9	889.7	893.6	936.4

The selection of the reference crystal frequency is based on some assumptions. As for example: the image frequency should not be in a radio band where strong interfering signals might occur (because they could represent parasitic receiving signals), the LO signal should be in the range of 800 MHz to 930 MHz (because this is the optimum frequency range of the VCO1). Furthermore the IF should be as high as possible to achieve highest RF image rejection. The columns in bold depict the selected frequency plans to receive at 868.3 MHz and 915 MHz, respectively.

2 FSK Application Circuits

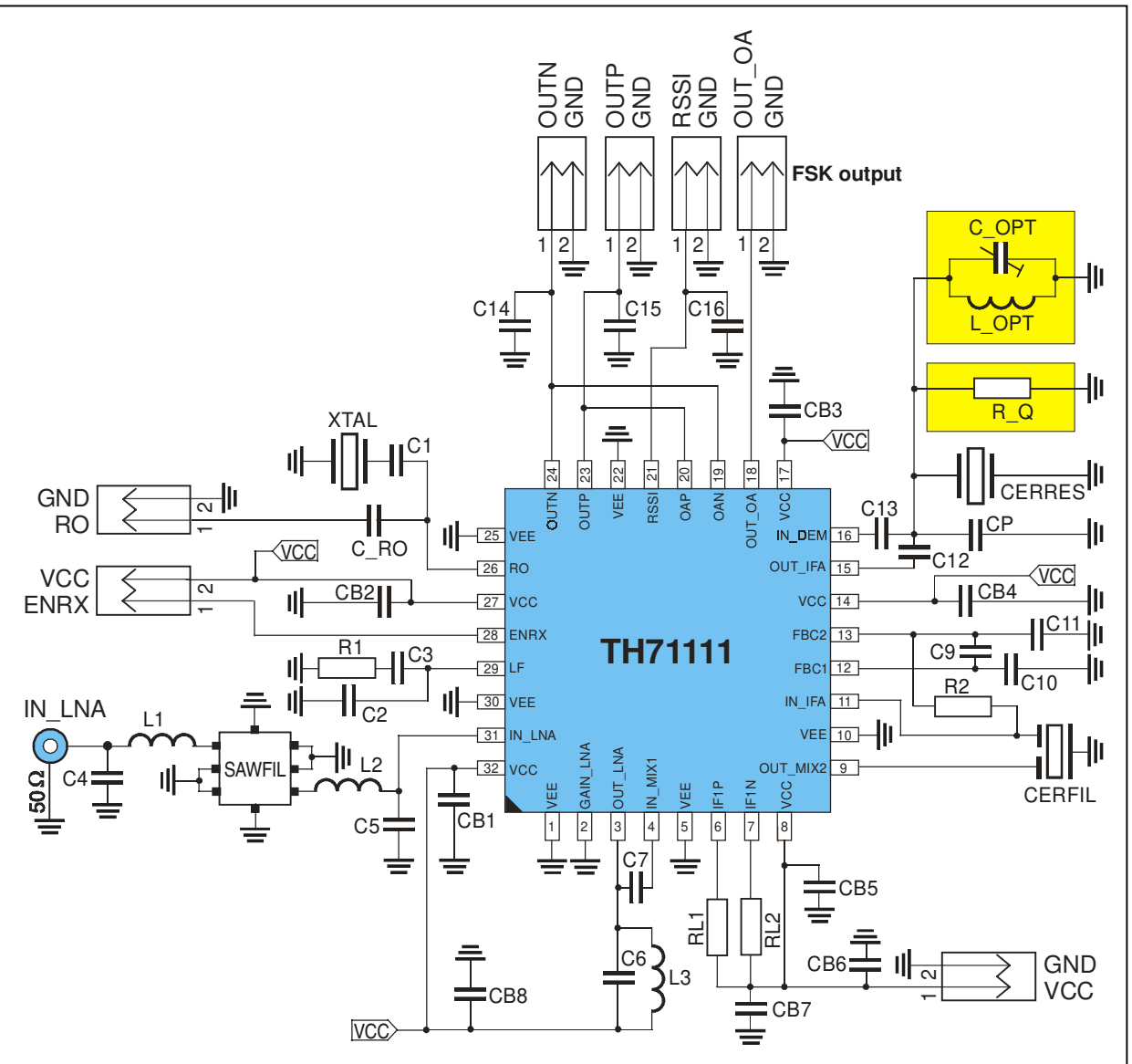
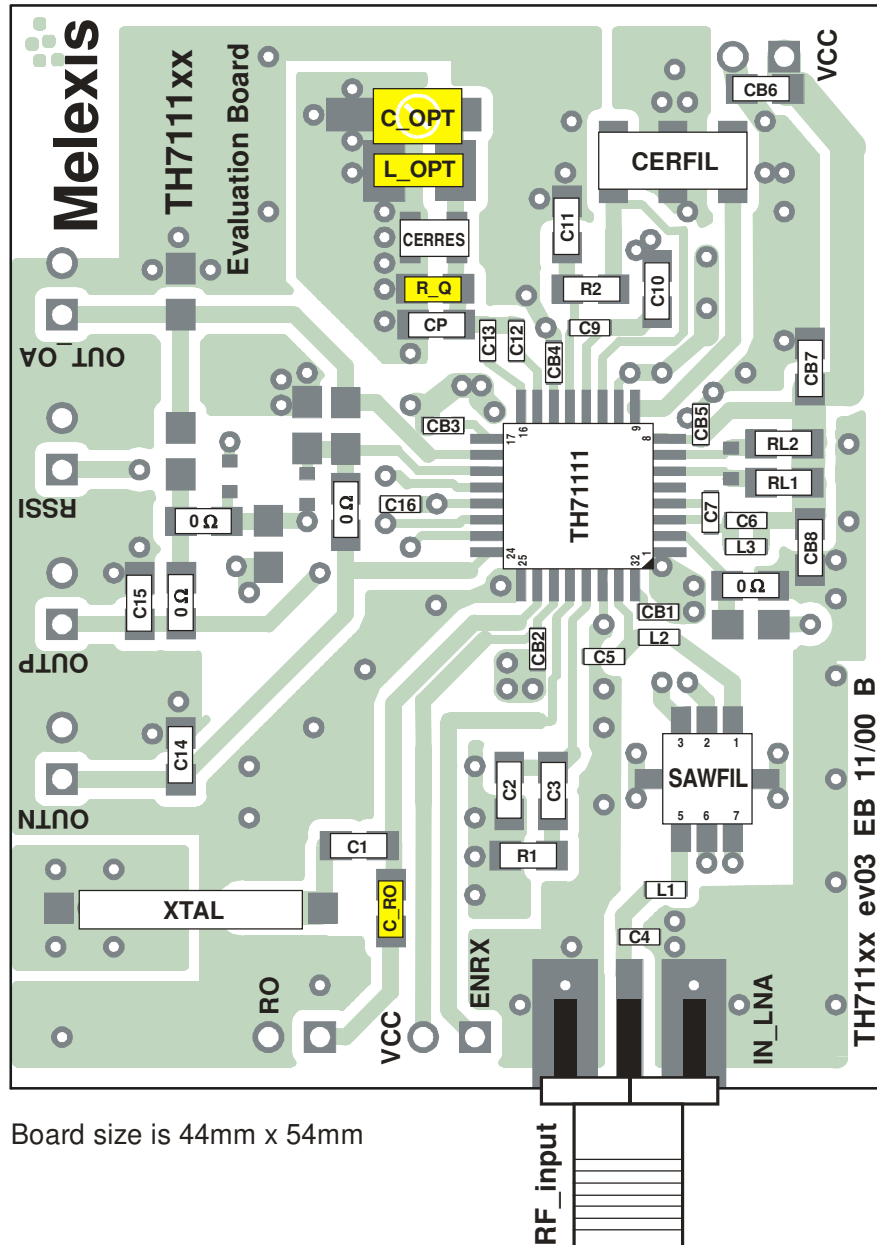

Fig. 2: Circuit diagram for FSK reception

2.1 PCB Top View for FSK Reception

Board layout data in Gerber format is available



Board size is 44mm x 54mm

2.2 Board Component Values for FSK (Fig. 2)

Part	Size	Value @ 868.3 MHz	Value @ 915 MHz	Tolerance	Description
C1	0805	15 pF	15 pF	±10%	crystal series capacitor
C2	0805	NIP	NIP	±10%	optional loop filter capacitor
C3	0805	1 nF	1 nF	±10%	loop filter capacitor
C4	0603	4.7 pF	NIP	±5%	capacitor to match to SAW filter input
C5	0603	2.7 pF	NIP	±5%	capacitor to match to SAW filter output
C6	0603	NIP	NIP	±5%	LNA output tank capacitor
C7	0603	1.2 pF	0.47 pF	±5%	MIX1 input matching capacitor
C8	0603	NIP	NIP	±5%	IF1 tank capacitor
C9	0805	33 nF	33 nF	±10%	IFA feedback capacitor
C10	0603	1 nF	1 nF	±10%	IFA feedback capacitor
C11	0603	1 nF	1 nF	±10%	IFA feedback capacitor
C12	0603	1.5 pF	1.5 pF	±5%	DEMODO phase-shift capacitor
C13	0603	680 pF	680 pF	±10%	DEMODO coupling capacitor
CP	0805	10 – 12 pF	10 – 12 pF	±5%	CERRES tuning capacitor
C14	0805	10 – 47 pF	10 – 47 pF	±5%	demodulator output low-pass capacitor, depending on data rate
C15	0805	10 – 47 pF	10 – 47 pF	±5%	demodulator output low-pass capacitor, depending on data rate
C16	0603	1.5 nF	1.5 nF	±10%	RSSI output low-pass capacitor
CB1 to CB5 CB7 to CB8	0603	330 pF	330 pF	±10%	blocking capacitor for VCC
CB6	0805	33 nF	33 nF	±10%	blocking capacitor for VCC
R1	0805	10 kΩ	10 kΩ	±10%	loop filter resistor
R2	0805	390 Ω	390 Ω	±5%	CERFIL output matching resistor
RL1	0805	470 Ω	470 Ω	±5%	MIX1 bias resistor
RL2	0805	470 Ω	470 Ω	±5%	MIX1 bias resistor
L1	0603	12 nH	18 nH	±5%	Inductor, to match SAW filter
L2	0603	12 nH	C=220 pF	±5%	Inductor (capacitor), to match SAW filter
L3	0603	6.8 nH	6.8 nH	±5%	LNA output tank inductor
L_OPT	1006	NIP	NIP	±5%	demodulator phase shift inductor, only required at FSK/FM with LC resonator
C_OPT	3mm	NIP	NIP	±5%	demodulator phase shift capacitor, only required at FSK/FM with LC resonator
R_Q	0805	NIP	NIP	±5%	optional lower-Q resistor, only required at FSK/FM with LC resonator
C_RO	0805	330 pF	330 pF	±5%	optional capacitor to couple external RO signal
XTAL	HC49 SMD	26.80000 MHz @ RF = 868.3 MHz	28.25938 MHz @ RF = 915 MHz	±25ppm calibr. ±30ppm temp.	fundamental-mode crystal, C _{load} = 10 pF to 15pF, C _{0, max} = 7 pF, R _{m, max} = 50 Ω
SAWFIL	QCC8C	B3570 (f ₀ = 868.30 MHz)		B _{3dB} = 1.7 MHz	low-loss SAW filter from EPCOS
			B3569 (f ₀ = 914.50 MHz)	B _{3dB} = 25 MHz	
CERFIL	Leaded type	SFE10.7MFP @ B _{IF2} = 40 kHz	SFE10.7MFP @ B _{IF2} = 40 kHz	TBD	ceramic filter from Murata
	SMD type	SFECV10.7MJS-A @ B _{IF2} = 150 kHz	SFECV10.7MJS-A @ B _{IF2} = 150 kHz	±40 kHz	
CERRES	SMD type	CDACV10.7MG18-A Murata	CDACV10.7MG18-A Murata		ceramic demodulator tank, not required at FSK/FM with LC resonator

NIP – not in place, may be used optionally

3.1 PCB Top View for ASK Reception

Board layout data in Gerber format is available

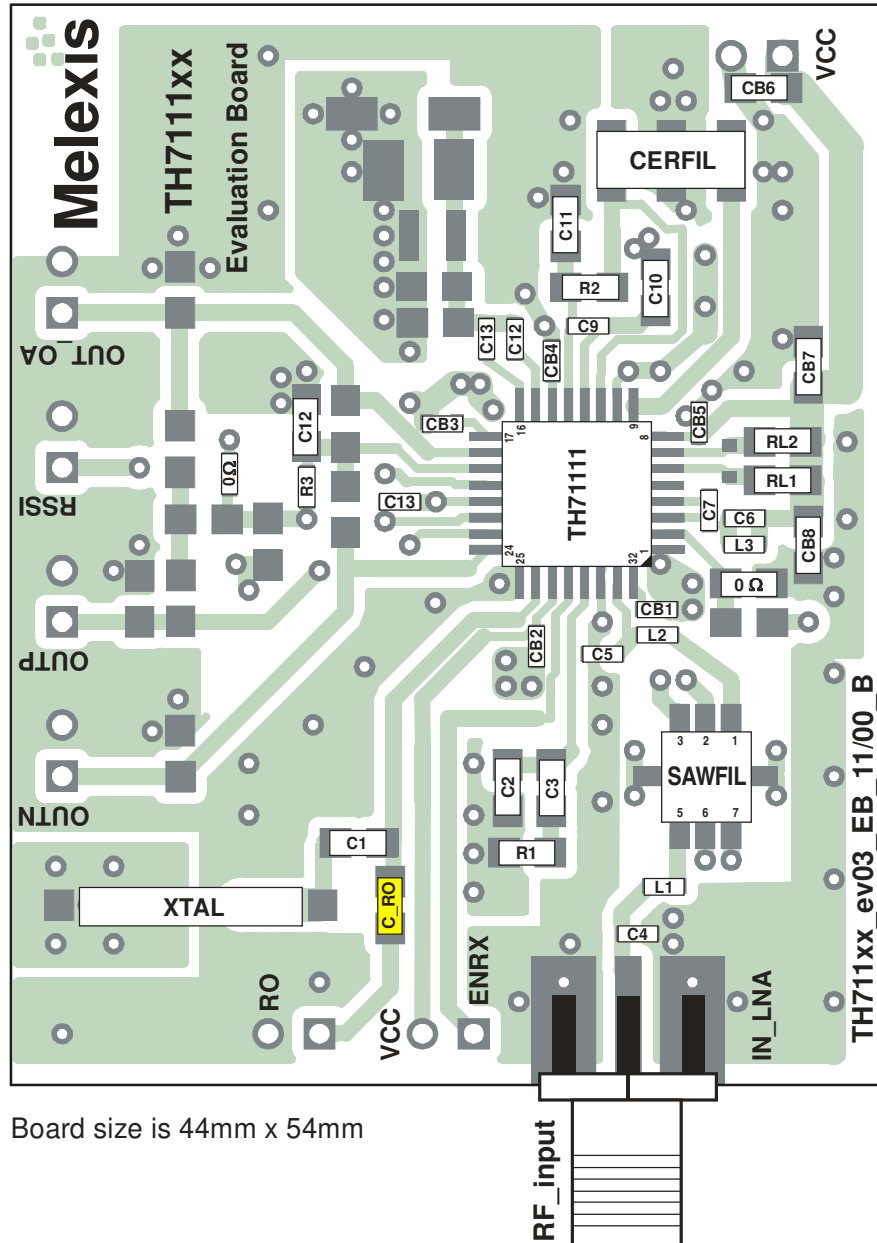

Board size is 44mm x 54mm

3.2 Board Component Values for ASK (Fig. 3)

Part	Size	Value @ 868.3 MHz	Value @ 915 MHz	Tolerance	Description
C1	0805	15 pF	15 pF	±10%	crystal series capacitor
C2	0805	NIP	NIP	±10%	optional loop filter capacitor
C3	0805	1 nF	1 nF	±10%	loop filter capacitor
C4	0603	4.7 pF	NIP	±5%	capacitor to match to SAW filter input
C5	0603	2.7 pF	NIP	±5%	capacitor to match to SAW filter output
C6	0603	NIP	NIP	±5%	LNA output tank capacitor
C7	0603	1.2 pF	0.47 pF	±5%	MIX1 input matching capacitor
C8	0603	NIP	NIP	±5%	IF1 tank capacitor
C9	0805	33 nF	33 nF	±10%	IFA feedback capacitor
C10	0603	1 nF	1 nF	±10%	IFA feedback capacitor
C11	0603	1 nF	1 nF	±10%	IFA feedback capacitor
C12	0805	1 nF to 100 nF	1 nF to 100 nF	±10%	ASK data slicer capacitor, depending on data rate
C13	0603	1.5 nF	1.5 nF	±10%	RSSI output low-pass capacitor
CB1 to CB5 CB7 to CB8	0603	330 pF	330 pF	±10%	blocking capacitor for VCC
CB6	0805	33 nF	33 nF	±10%	blocking capacitor for VCC
R1	0805	10 kΩ	10 kΩ	±10%	loop filter resistor
R2	0805	330 Ω	330 Ω	±5%	CERFIL output matching resistor
R3	0603	100 kΩ	100 kΩ	±5%	ASK data slicer resistor, depending on data rate
R4	0805	15 kΩ	TBD	±5%	AGC time constant resistor
RL1	0805	470 Ω	470 Ω	±5%	MIX1 bias resistor
RL2	0805	470 Ω	470 Ω	±5%	MIX1 bias resistor
L1	0603	12 nH	18 nH	±5%	Inductor, to match SAW filter
L2	0603	12 nH	C=220 pF	±5%	Inductor (capacitor), to match SAW filter
L3	0603	6.8 nH	6.8 nH	±5%	LNA output tank inductor
C_RO	0805	330 pF	330 pF	±5%	optional capacitor to couple external RO signal
XTAL	HC49 SMD	26.80000 MHz @ RF = 868.3 MHz	28.25938 MHz @ RF = 915 MHz	±25ppm calibr. ±30ppm temp.	fundamental-mode crystal, C _{load} = 10 pF to 15pF, C _{0, max} = 7 pF, R _{m, max} = 50 Ω
SAWFIL	QCC8C	B3570 (f ₀ = 868.30 MHz)			B _{3dB} = 1.7 MHz
			B3569 (f ₀ = 914.50 MHz)		B _{3dB} = 25 MHz
CERFIL	Leaded type	SFE10.7MFP @ B _{IF2} = 40 kHz	SFE10.7MFP @ B _{IF2} = 40 kHz	TBD	ceramic filters from Murata
	SMD type	SFECV10.7MJS-A @ B _{IF2} = 150 kHz	SFECV10.7MJS-A @ B _{IF2} = 150 kHz	±40 kHz	ceramic filters from Murata

NIP – not in place, may be used optionally

4 Package Dimensions

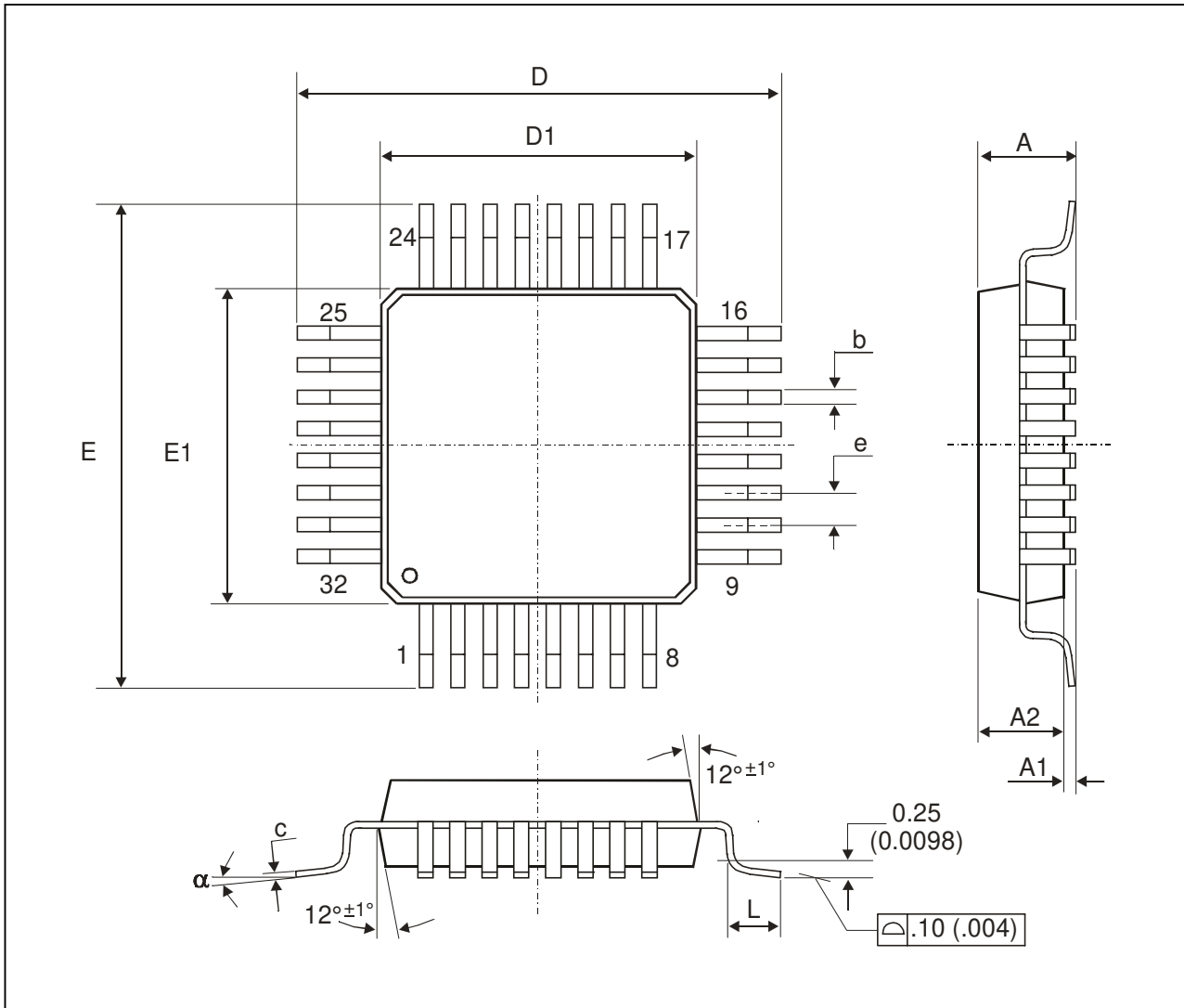

Fig. 4: LQFP32 (Low profile Quad Flat Package)

All Dimension in mm, coplanarity < 0.1mm										
	E1, D1	E, D	A	A1	A2	e	b	c	L	α
min	7.00	9.00	1.40	0.05	1.35	0.8	0.30	0.09	0.45	0°
max			1.60	0.15	1.45		0.45	0.20	0.75	7°
All Dimension in inch, coplanarity < 0.004"										
min	0.276	0.354	0.055	0.002	0.053	0.031	0.012	0.0035	0.018	0°
max			0.063	0.006	0.057		0.018	0.0079	0.030	7°

5 Reliability Information

Melexis devices are classified and qualified regarding suitability for infrared, vapor phase and wave soldering with usual (63/37 SnPb-) solder (melting point at 183degC).

The following test methods are applied:

- IPC/JEDEC J-STD-020A (issue April 1999)
Moisture/Reflow Sensitivity Classification For Nonhermetic Solid State Surface Mount Devices
- CECC00802 (issue 1994)
Standard Method For The Specification of Surface Mounting Components (SMDs) of Assessed Quality
- MIL 883 Method 2003 / JEDEC-STD-22 Test Method B102
Solderability

For all soldering technologies deviating from above mentioned standard conditions (regarding peak temperature, temperature gradient, temperature profile etc) additional classification and qualification tests have to be agreed upon with Melexis.

The application of Wave Soldering for SMD's is allowed only after consulting Melexis regarding assurance of adhesive strength between device and board.

For more information on manufacturability/solderability see quality page at our website:

<http://www.melexis.com/>

6 ESD Precautions

Electronic semiconductor products are sensitive to Electro Static Discharge (ESD).

Always observe Electro Static Discharge control procedures whenever handling semiconductor products.

7 Disclaimer

Devices sold by Melexis are covered by the warranty and patent indemnification provisions appearing in its Term of Sale. Melexis makes no warranty, express, statutory, implied, or by description regarding the information set forth herein or regarding the freedom of the described devices from patent infringement. Melexis reserves the right to change specifications and prices at any time and without notice. Therefore, prior to designing this product into a system, it is necessary to check with Melexis for current information. This product is intended for use in normal commercial applications. Applications requiring extended temperature range, unusual environmental requirements, or high reliability applications, such as military, medical life-support or life-sustaining equipment are specifically not recommended without additional processing by Melexis for each application.

The information furnished by Melexis is believed to be correct and accurate. However, Melexis shall not be liable to recipient or any third party for any damages, including but not limited to personal injury, property damage, loss of profits, loss of use, interrupt of business or indirect, special incidental or consequential damages, of any kind, in connection with or arising out of the furnishing, performance or use of the technical data herein. No obligation or liability to recipient or any third party shall arise or flow out of Melexis' rendering of technical or other services.

© 2002 Melexis NV. All rights reserved.

For the latest version of this document. Go to our website at
www.melexis.com

Or for additional information contact Melexis Direct:

Europe and Japan:
Phone: +32 1367 0495
E-mail: sales_europe@melexis.com

All other locations:
Phone: +1 603 223 2362
E-mail: sales_usa@melexis.com

QS9000, VDA6.1 and ISO14001 Certified