



Chipsmall Limited consists of a professional team with an average of over 10 year of expertise in the distribution of electronic components. Based in Hongkong, we have already established firm and mutual-benefit business relationships with customers from,Europe,America and south Asia,supplying obsolete and hard-to-find components to meet their specific needs.

With the principle of “Quality Parts,Customers Priority,Honest Operation,and Considerate Service”,our business mainly focus on the distribution of electronic components. Line cards we deal with include Microchip,ALPS,ROHM,Xilinx,Pulse,ON,Everlight and Freescale. Main products comprise IC,Modules,Potentiometer,IC Socket,Relay,Connector.Our parts cover such applications as commercial,industrial, and automotives areas.

We are looking forward to setting up business relationship with you and hope to provide you with the best service and solution. Let us make a better world for our industry!



Contact us

Tel: +86-755-8981 8866 Fax: +86-755-8427 6832

Email & Skype: info@chipsmall.com Web: www.chipsmall.com

Address: A1208, Overseas Decoration Building, #122 Zhenhua RD., Futian, Shenzhen, China



16 mm Square Encoders

Type: **EVEP/EVEQ**



■ Features

- Good operational feel
- Long life with high click torque
- Shaft wobble : 0.1 mm max.

■ Recommended Applications

- Centralized control of automotive audio equipment, navigation systems, and air conditioners.

■ Explanation of Part Numbers

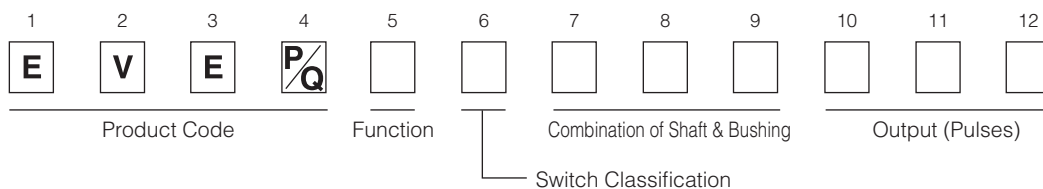

■ Specifications

		EVEP	EVEQ
Mechanical	Rotation Angle	360 ° (Endless)	
	Shaft Pull/Push Strength	100 N min.	
	Shaft Wobble	0.1 mm max.(Length form mounting surface : 21.5 mm) (50 mN·m is applied on the point 2 mm from the shaft tip)	
	Rotation Torque	25 mN·m max.	
	Detents	16 points	32 points
Electrical	Output Signals	Phase A and B	
	Resolution	8 pulses/ 360 °	16 pulses/ 360 °
	Rating	1 mA 10 V DC (at each bit)	
	Contact Resistance	1 Ω max.	
	Chattering	5 ms max.	
	Insulation Resistance	50 MΩ min. (at 250 V DC)	
	Dielectric Withstanding Voltage	300 V AC for 1 minute	
Switch Part	Bouncing	5 ms max.	
	Type	SPST Push-on	
	Rating	20 mA 16 V DC	
	Contact Resistance	100 mΩ max.	
	Operating Force	6 N	
Endurance	Travel	0.5 mm	
	Rotation Life (Encoder)	1,000,000 cycles min.	30,000 cycles min.
	Operating Life (Switch)	1,000,000 cycles min.	30,000 cycles min.
Minimum Quantity/Packing Unit		50 pcs. (Tray Pack)	
Quantity/Carton		200 pcs.	

Design and specifications are each subject to change without notice. Ask factory for the current technical specifications before purchase and/or use.
Should a safety concern arise regarding this product, please be sure to contact us immediately.

■ Dimensions in mm (not to scale)

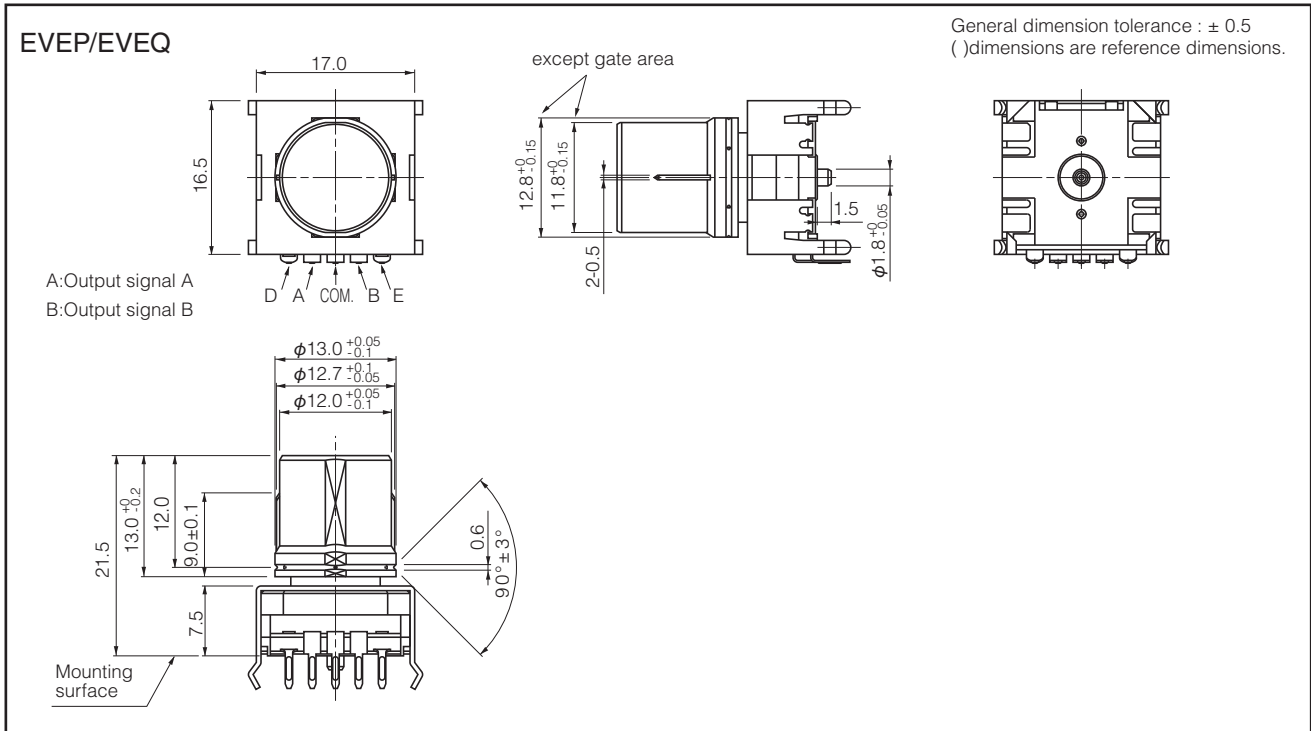

■ PWB mounting hole for reference

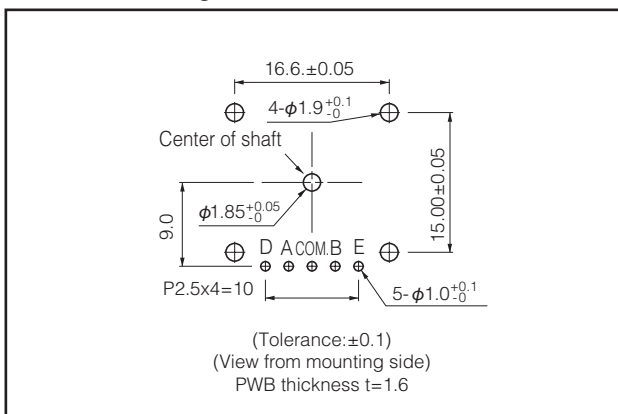

■ Encoder / Switch Circuit

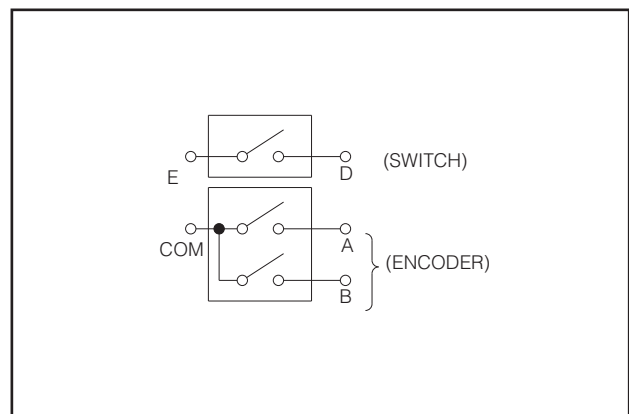

■ Phase Difference

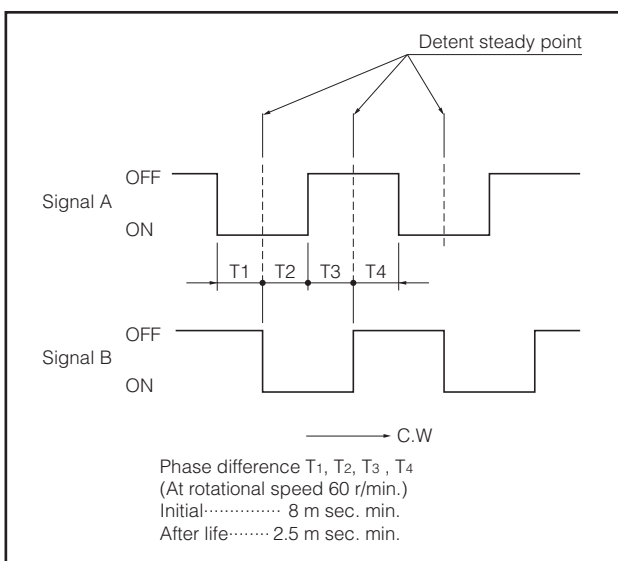

■ Test Circuit Diagram

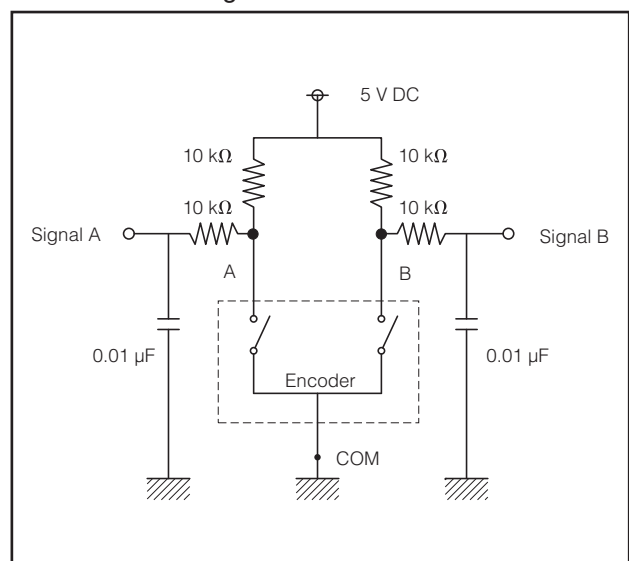

Design and specifications are each subject to change without notice. Ask factory for the current technical specifications before purchase and/or use.
 Should a safety concern arise regarding this product, please be sure to contact us immediately.