



Chipsmall Limited consists of a professional team with an average of over 10 year of expertise in the distribution of electronic components. Based in Hongkong, we have already established firm and mutual-benefit business relationships with customers from,Europe,America and south Asia,supplying obsolete and hard-to-find components to meet their specific needs.

With the principle of “Quality Parts,Customers Priority,Honest Operation,and Considerate Service”,our business mainly focus on the distribution of electronic components. Line cards we deal with include Microchip,ALPS,ROHM,Xilinx,Pulse,ON,Everlight and Freescale. Main products comprise IC,Modules,Potentiometer,IC Socket,Relay,Connector.Our parts cover such applications as commercial,industrial, and automotives areas.

We are looking forward to setting up business relationship with you and hope to provide you with the best service and solution. Let us make a better world for our industry!



Contact us

Tel: +86-755-8981 8866 Fax: +86-755-8427 6832

Email & Skype: info@chipsmall.com Web: www.chipsmall.com

Address: A1208, Overseas Decoration Building, #122 Zhenhua RD., Futian, Shenzhen, China



GENERAL DISTRIBUTION

Issue No. : RV-H-1719

Date of Issue : Dec.6.2012

Classification : New Change

PRODUCT SPECIFICATION FOR APPROVAL

Product Description: : ENCODER
Product Part Number : (Panasonic Part Number : EVEWRHJR012B)
Country of Origin : VIETNAM (Indicated on the packing label in English)
Applications : Model :

* In case of use other than the application described above, contact Panasonic representatives.

* If you approve this specification, please fill in and sign the below and return 1 copy to us.

Approval No. :

Approval Date :

Executed by :

(Signature)

Title :

Dept. :

Electromechanical Components Business Unit
Industrial Devices Company

1006 Kadoma, Kadoma City, Osaka, Japan

Phone: (06) 6908-7304 (Direct)

Prepared by : Input Devices Development Team
Contact Person : Engineering Group

Signature : H. Sadamori

Name (Print) : H.Sadamori

Title : Staff Engineer

Phone : +81-868-26-3791

Authorized by : M. Sawada
Signature

Name (Print) : M.Sawada

Title : Team Leader of Engineering

Panasonic

THIRD ANGLE PROJECTION

ALL DIMENSIONS ARE IN MILLIMETERS.

DO NOT SCALE DRAWING

General dimension tolerance : ± 0.5 ():Reference dimension

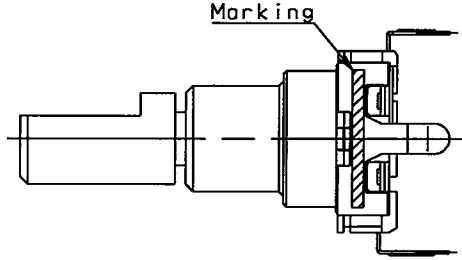
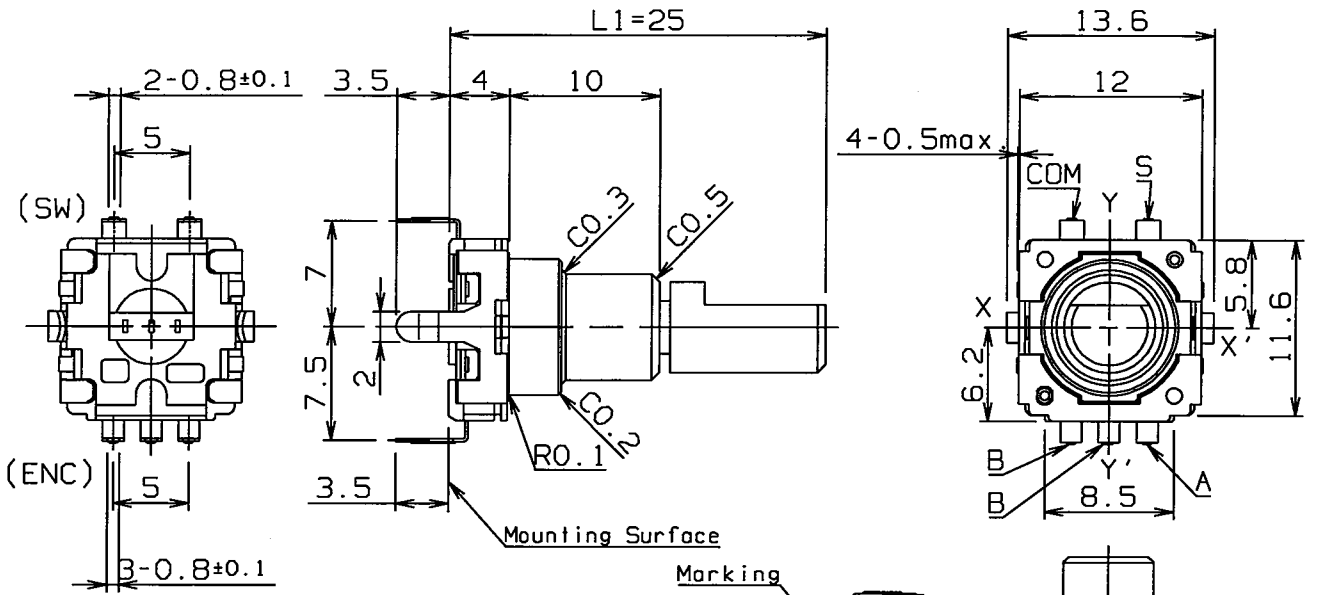

Shaft shape and dimension

Shaft position will be at random.

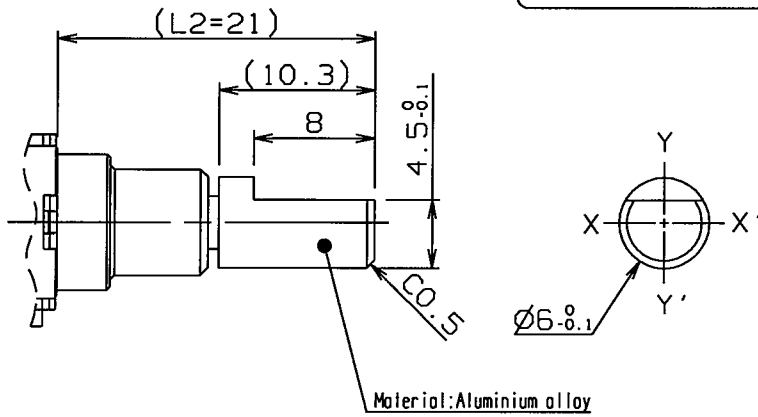

P.W.B. piercing plan.

(Tolerance : ± 0.1)
(View from mounting side)
P.W.B thickness $t=1.6$

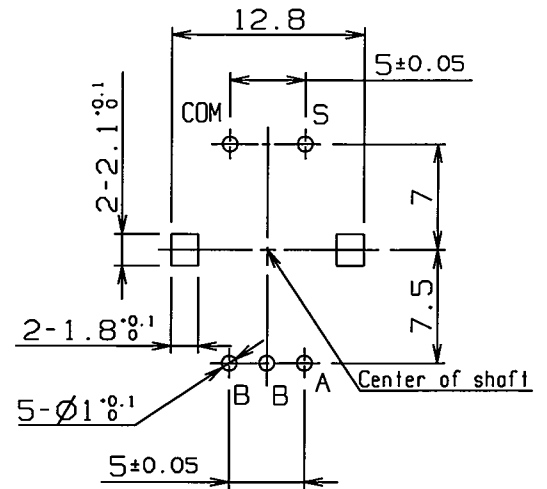

DESIGN	S.Ikeda	Dec. 6.2012	NAME	11mm GS ENCODER	ISSUE	REVISIONS	DATE
DRAW							
CHECK	<i>M. Sawada</i>	Dec. 6. '12	TYPE NO.	EVEWRHJR012B	DRAWING NO.		
APPROVAL	<i>M. Sawada</i>	Dec. 7. '12			RV-H- 1719		1/7

General

1. Scope: This specification applies to rotary encoder(incremental type) used in electronic equipment.
2. Standard atmospheric conditions: Unless otherwise specified. The standard range of atmospheric conditions for making measurements and tests is as follows.
 - Ambient temperature : 15°C ~ 35°C
 - Relative humidity : 25% ~ 75%
 - Air pressure : 86kPa ~ 106kPa
3. Operating temperature range : -40°C ~ +85°C
4. Storage temperature range : -40°C ~ +85°C
5. Rated voltage : Encoder D.C 10V
Switch D.C 16V
6. Rated current : Encoder D.C 1mA
Switch D.C 20mA

Production country : VIETNAM
Marked on package label as "MADE IN VIETNAM"

Mechanical characteristics

Item		Conditions	Specifications	
1	Rotation angle		360° (Endless)	
2	Detent points		24 detent points	
3	Each detent angle		15.0° ±3.0°	
4	Rotation torque (Detent torque)	Operating temperature	5°C ~ 85°C	12.0 mN·m ±6.0 mN·m
			-20°C ~ 5°C	40 mN·m max.
			-40°C ~ -20°C	50 mN·m max.
5	Shaft pull-push strength	Pull and push static load of 100N shall be applied to the shaft in the axial direction for 10 second. (Mount the product to P.W.B.)	Without damage or excessive play in shaft. No excessive abnormality in rotational feeling. And electrical characteristics shall be satisfied.	
6	Shaft side-load strength	A momentary load of 0.5 Nm shall be applied at the point 5mm from the tip of the shaft in a direction perpendicular to the axis of shaft for 10 second. (Mount the product to P.W.B.)	Without excessive play or bending in shaft. No excessive abnormality in rotational feeling. And electrical characteristics shall be satisfied.	
7	Shaft wobble	A momentary load of 50 mNm shall be applied at the point 2mm from the tip of the shaft in a direction perpendicular to the axis of shaft. (Mount the product to P.W.B.)	0.5xL/30 mm(P-P)max. L :Distance between mounting surface and measuring point on the shaft.	
8	Shaft play in rotational wobble	Measure with jig for rotational angle.	2° max.(Initial)	

NAME	11mm GS ENCODER	ISSUE	REVISIONS	DATE
TYPE NO.	EVEWRHJR012B	DRAWING NO.	RV-H- 1719	2/7

Electrical characteristics(encoder)

Item	Conditions	Specifications
1 Output signal	(Output of phase difference Fig-1)	A,B 2 signals.
2 Output resolution	Number of pulses in 360° rotation.	12 Pulse / 360°
3 Contact resistance	Measurement shall be stable condition which a output signal is ON condition.	1Ω max.
4 Bouncing	Measurement circuit diagram.(Fig-2) At rotational speed 60 min ⁻¹ <Phase t1,t3 (Fig-3)> (Passing time between 3.5V and 1.5V)	t1, t3: 5 ms max.
5 Sliding noise phase t2	Take sliding noise as time in the code-on area between bouncing(t1,t3) and voltage change exceed 1.5V.(Fig-3) Rotate shaft at speed 60±3 min ⁻¹ and measure.	3 ms max.
6 Phase-difference	Measurement shall be made under the condition which the shaft is rotated at 60 min ⁻¹ .	T1, T2, T3, T4 (Fig-1) 4 ms min.
7 Insulation resistance	Measurement shall be made under the condition which a voltage of 250V D.C. is applied between individual terminals and a shaft.	50MΩ min.
8 Withstand voltage	A voltage of 300V A.C. shall be applied for 1min. between individual terminals and a shaft.	Without arcing or breakdown.

Switch characteristics(switch)

Item	Conditions	Specifications
1 Switch type		Push type S.P.S.T.
2 Contact resistance	Measurement the contact resistance between COM and SW when push SW is ON. Applying force: 8.5N	100mΩ max.
3 Switch operation force	Measure the max.load until switch turned on when pressing the center of shaft to the operation direction of push SW.	6.0 N ± 2.5 N
4 Push stroke	Measure the distance until switch turned on when pressing the center of shaft to the operation direction of push SW.	0.4 mm ^{+0.5} / _{-0.2} mm (At push force 8.5N)
		0.3 mm ^{+0.25} / _{-0.15} mm (Travel to ON)
5 Bouncing	Measurement circuit diagram.(Fig-4) At operation speed 3~4 times/s <Phase t4,t5 (Fig-5)> (Passing time between 1.5V and 3.5V)	t4, t5: 10 ms max.
6 Insulation resistance	Measurement shall be made under the condition which a voltage of 250V D.C. is applied between individual terminals and a shaft.	50MΩ min.
7 Withstand voltage	A voltage of 300V A.C. shall be applied for 1min. between individual terminals and a shaft.	Without arcing or breakdown.

NAME	11mm GS ENCODER	ISSUE	REVISIONS	DATE
TYPE NO.	EVEWRHJR012B	DRAWING NO.	RV-H- 1719	3/7

Phase difference.

(Fig-1)

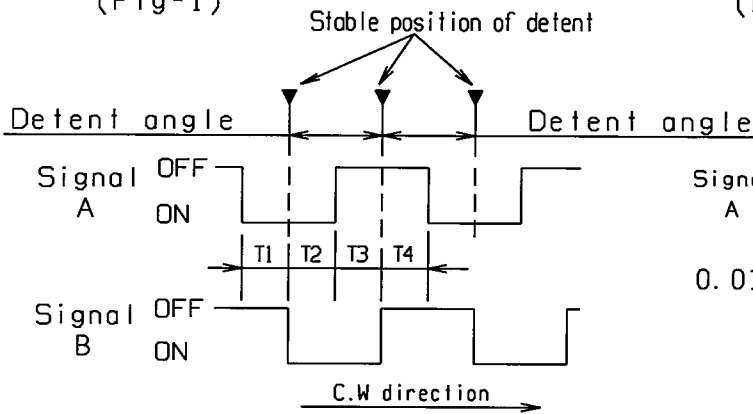

Measurement circuit diagram.

(Fig-2)

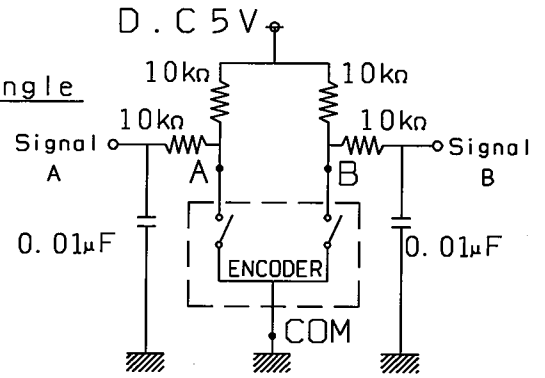

At each detent position, output between COM and A is stable ON or OFF.
(Output between COM and B is not specified.)

Bouncing phase(Fig-3)

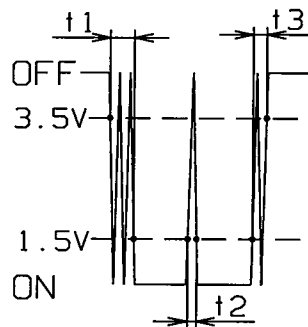

Measurement circuit diagram.(Fig-4)

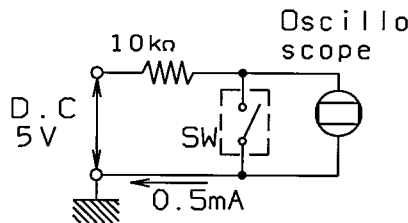

Bouncing phase(Fig-5)

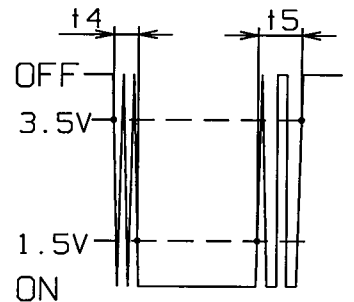

Encoder terminal layout and switch circuit diagram.

(Fig-6)

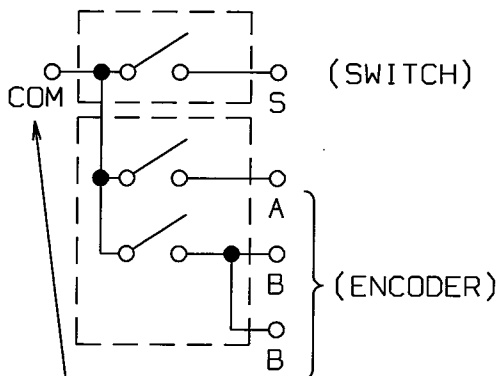

(SWITCH)

(ENCODER)

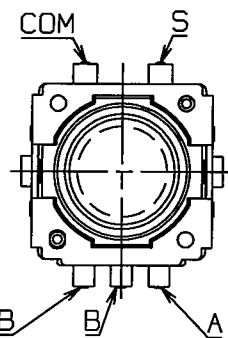

ENCODER: A:Output signal A
B:Output signal B

SWITCH: S:Output signal for switch

(Notice)

Common terminal is shared between encoder and switch

NAME

11mm GS ENCODER

ISSUE

REVISIONS

DATE

TYPE NO.

EVEWRHJR012B

DRAWING NO.

RV-H- 1719

4/7

Durability

Item	Conditions	Specifications
1 Rotation life (Encoder)	The shaft of encoder shall be rotated to 200,000cycles at a speed of 600 to 1000 cycles/h in room temp(5°C to 35°C) without electrical load after which measurements shall be made.	Rotation torque: Initial torque $\pm 70\%$ Phase-difference: 2.5 ms min. Contact resistance: 100 Ω max. Electrical characteristics item: 4,5,7,8 The same as the initial specifications.
2 Push operating life (Switch)	Apply 8.5N push strength to shaft to the switch operating direction. The shaft of encoder shall be pushed to 200,000 times at a speed of 2500 times/h in room temp(5°C to 35°C) without electrical load after which measurements shall be made.	Operation force: Initial operation force $\pm 40\%$ Contact resistance: 200 Ω max. Switch characteristics item: 4,5,6,7 The same as the initial specifications.
3 Heat temperature	The encoder shall be stored at a temperature of $85\pm 3^\circ\text{C}$ for $240\pm 10\text{h}$ in a thermostatic chamber. And then the encoder shall be subjected to standard atmospheric conditions for 1.5h after which measurements shall be made. (Without electrical load)	Contact resistance: 100 Ω max. SW Contact resistance: 200 Ω max. Mechanical characteristics item: 4 Electrical characteristics item: 4,5,6,7,8 Switch characteristics item: 3,4,5,6,7 The same as the initial specifications.
4 Humidity	The encoder shall be stored at a temperature of $60\pm 3^\circ\text{C}$ with relative humidity of 90% to 95% for $240\pm 10\text{h}$ in a thermostatic chamber. And then the encoder shall be subjected to standard atmospheric conditions for 1.5h after which measurements shall be made. (Without electrical load)	
5 Low temperature	The encoder shall be stored at a temperature of $-40\pm 3^\circ\text{C}$ for $240\pm 10\text{h}$ in a thermostatic chamber. And then the encoder shall be subjected to standard atmospheric conditions for 1.5h after which measurements shall be made. (Without electrical load)	

Packing:

- (1) Package style : Card board box.(500pcs./Packaging)
- (2) Package size : L=374xW=272xH=116
- (3) Tray style : Plastic tray.(100pcs./tray)
- (4) Tray size : L=356xW=260xH=19.4

Marking

1. Date code
2. Output signal

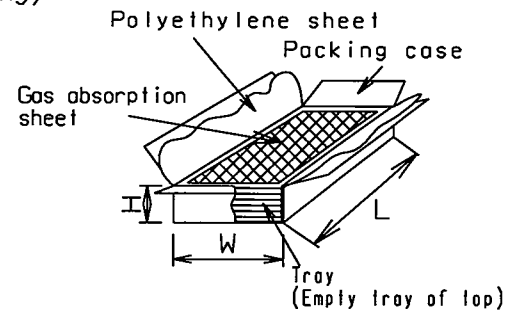

Handling of approval specification :

1. This specification from specify this item only. Please perform your approval test in the actual equipment conditions beforehand.
2. Writing in this specification from are subject to change through precautions.

NAME	11mm GS ENCODER	ISSUE	REVISIONS	DATE
TYPE NO.	EVEWRHJR012B	DRAWING NO.	RV-H- 1719	5/7

⚠ Application Notes :

1. Prohibited items on fire and smoking

Absolutely avoid use of a product beyond its rated range because doing so may cause a fire. If misuse or abnormal use may result under conditions in which the product is used out of its rated range, take proper measures such as current interruption using a protective circuit.

The grade of nonflammability for resin used in product is "94HB," which is based on UL94 Standards (flammability test for plastic materials).

Prohibit use in a location where a spreading fire may be generated or prepare against a spreading fire.

2. For use in equipment for which safety is requested

Although care is taken to ensure product quality, inferior Characteristics, short circuits, and open circuits are some problems that might be generated. To design a equipment which places maximum emphasis on safety, review the affect of any single fault of a product in advance and perform virtually fail-safe design to ensure maximum safety by:

- Preparing a protective circuit or a protective device to improve system safety, and set
- Preparing a redundant circuit to improve system safety so that the single fault of a product does not cause a dangerous situation.

3. Reliability

Storage condition

Do not store the product under high temperatures and/or high humidity, or in a location where corrosive gas may be generated.

Store the product at room temperature and room humidity in a packed condition.

Use them within a maximum of 6 months.

Check the date of manufacture on the package box and apply the "first-in-first-out" rule.

If unpacked product must be stored as inventory, Store them in polyethylene bag to keep out air.

The encoder's pulse count method should be designed with taking operating speed, sampling time, and the design of the microcomputer software, etc. into consideration.

The item designed mainly corresponds to JIS (Japanese Industrial Standards) on the reliability conditions.

4. This product does not yet conform to Halogen Free regulation generally required.

Information of Chemical Substances and Environmental Hazardous Substances.

This product has not been manufactured with ozone depleting chemical controlled under the Montreal Protocol.

This product complies with the RoHS Directive Restriction of the use of certain Hazardous Substance in electrical and electronic equipment (DIRECTIV2011/65/EU).

All the materials used in the part are registered material under the Law Concerning the Examination and Regulation of Manufacture etc. or Chemical Substances.

Soldering conditions :

Perform the soldering under the conditions shown below.

Soldering conditions (1)

Specific gravity of flux ----- 0.83 ± 0.05

Flux foaming time ----- Within 5 s

Flux foaming level ----- 1/2t or less

Preheating temperature ----- 100 °C max. (Ambient temp.)

Preheating time ----- 70s max.

Soldering should be performed at 260 °C or less within 3 s by twice maximum.

Conditions of P.W.B Thickness Material ----- t=1.6 mm

Double side copper clad phenolic resin Laminates.

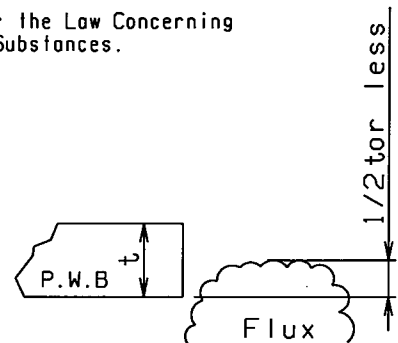

Soldering conditions (2)

<Soldering iron>

Soldering iron : 20W or lower.

Temperature at the iron tip : 350°C or lower.

The duration to apply the soldering iron : 3 seconds or lower. (1 time)

PWB design - When you design mounting hole of PWB, please refer to its dimension defined in this specification.

Particularly, care should be taken in the case of wiring such as jumper wire near the product body where flux is delating.

If flux is spattered to the product body, it may cause electrical contact or sliding trouble.

NAME	11mm GS ENCODER	ISSUE	REVISIONS	DATE
TYPE NO.	EVEWRHJR012B	DRAWING NO.	RV-H- 1719	6/7

