



Chipsmall Limited consists of a professional team with an average of over 10 year of expertise in the distribution of electronic components. Based in Hongkong, we have already established firm and mutual-benefit business relationships with customers from,Europe,America and south Asia,supplying obsolete and hard-to-find components to meet their specific needs.

With the principle of “Quality Parts,Customers Priority,Honest Operation,and Considerate Service”,our business mainly focus on the distribution of electronic components. Line cards we deal with include Microchip,ALPS,ROHM,Xilinx,Pulse,ON,Everlight and Freescale. Main products comprise IC,Modules,Potentiometer,IC Socket,Relay,Connector.Our parts cover such applications as commercial,industrial, and automotives areas.

We are looking forward to setting up business relationship with you and hope to provide you with the best service and solution. Let us make a better world for our industry!



## Contact us

Tel: +86-755-8981 8866 Fax: +86-755-8427 6832

Email & Skype: info@chipsmall.com Web: www.chipsmall.com

Address: A1208, Overseas Decoration Building, #122 Zhenhua RD., Futian, Shenzhen, China





## Using the EVK1060A:

This kit is for the evaluation and development of applications using the AT42QT1060-MMU ('QT1060') 6 Capacitive Touch™ Integrated Circuit (IC). In this example, the QT1060 is shown working in a battery powered 'Standalone' mode, but can be connected to a PC and/or User application by simple modifications/connections to the EVK1060A Evaluation Board.

The EVK1060A is configured with 6 capacitive keys (one as a 'Guard Channel'), 6 General Purpose Inputs/Outputs (GPIO's) as Outputs (LED 0 - 5) and the seventh GPIO as an input channel (SW1).

Please refer to the QT1060 datasheet available at [www.atmel.com](http://www.atmel.com) for full details.

- Ensure the EVK1060A Evaluation Board has 6x clear feet fitted to underside of the PCB.
- Insert the CR2032 3V battery provided into the battery holder on the EVK1060A. Ensure that the battery has the correct orientation (negative (-) side to board) or the EVK1060A will not work.
- The LEDs will illuminate in a set sequence, then extinguish.
- Touch and hold the ON/OFF symbol - Power LED will illuminate indicating power to the QT1060. Remove touch from the ON/OFF symbol.
- Touch any of the 5 key(s) (Rewind (K0), Play (K1), Pause (K2), Forward (K3), Stop (K4)) on the EV1060A and the corresponding LED(s) will illuminate. (The number of LED(s) illuminated will depend on the Adjacent Key Suppression™ (AKS™) feature setting at J1)
- If the Guard Channel (K5 which surrounds K0 - K4) is touched, then LED5 will illuminate.
- Touch and hold the ON/OFF symbol - The Power LED will extinguish to indicating power to the QT1060 has been removed. Remove touch from the ON/OFF symbol.
- The EVK1060A will power off after approximately 3 minutes of inactivity.



### Guard Channel:

K5 Electrode surrounds K0 - K4 electrodes and LED5 is driven by the 5029 to show when touch is detected on this channel. When AKS feature is on, this channel will can be used to indicate 'non-desired' touches (e.g. when a product is in a pocket or against an ear) and can be used to advise the User's host chip to ignore touches on other keys.

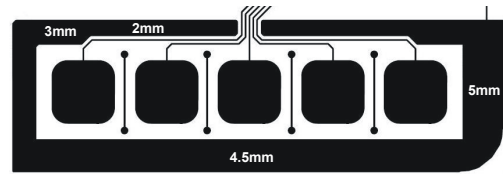

The width of the K5 electrode varies to show the Guard Channel effect. Compare the effect of touching at the 2mm wide area to the effect at the 5mm wide area.

### External Keyboard/Electrodes:

The EVK1060A can be connected to user electrodes, using pads adjacent to R0 - R5 and cutting the associated 6 tracks (LK4 - LK9 on the schematic).

The EVK1060A can be divided, if required, (a cutting tool is required) to separate the QT1060A circuit from the power and 5029 circuit.

### Input/Output:

The EVK2160A can be connected to User applications through I2C, using the /CHG, SCL, SDA pads.

The Plug-In USB card, Part Number 9206, which uses Atmel's AT90USB64 IC, can be connected to the connector J3. PC based software is available to further evaluate the QT1060 settings.

The seven GPIO's are available at the pads on the top edge of the EVK1060A.

### Sense Capacitors/Sensitivity:

C0 - C5 can be replaced with different value X7R capacitors to change the sensitivity of each of the channels K0 - K5 respectively. Increasing the capacitor values will increase sensitivity and decreasing the capacitor value will decrease the sensitivity. (All flux residues should be removed after component replacement.)

The sensitivity of all channels will increase if any pad/component connected to ground is touched. Compare touching a key when the EVK1060A is on a desk, to when the EVK1060A is picked up and held at the GND PAD.

### Power Supply:

An external power supply can be used instead of the supplied battery, but ensure that Schottky diodes are fitted to D1 and D2 to prevent cross powering of USB and battery sources.

It is advised to remove the battery when using an external power supply.

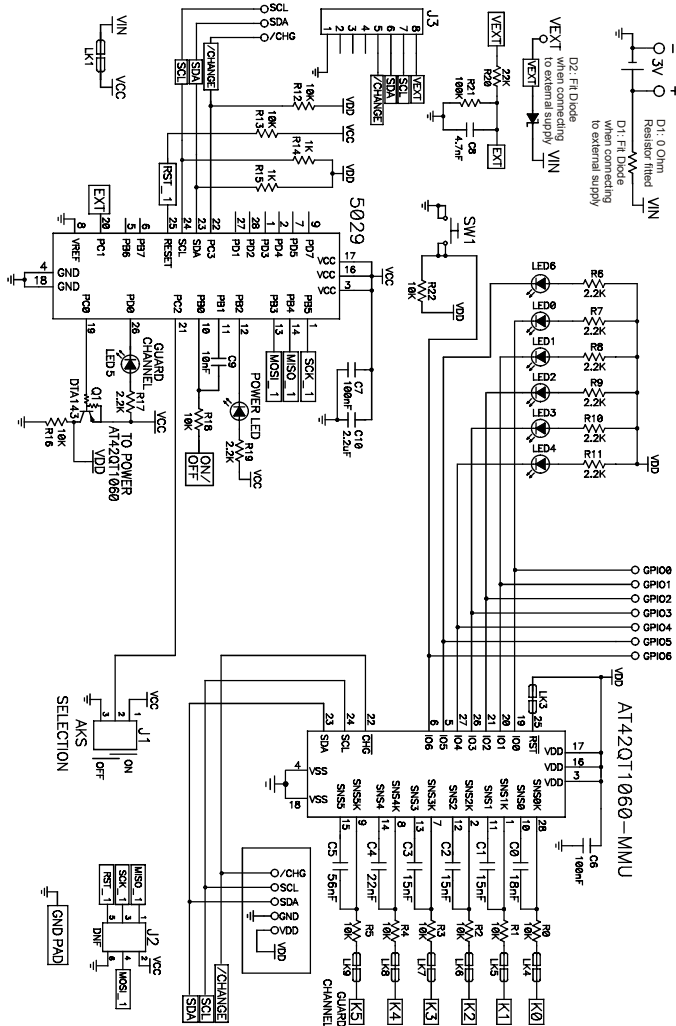

### 5029:

- Provides On/Off QTouch™ button, including auto power-off
- Determines whether connected to USB port/external I2C
- Sets the QT1060 through I2C: Default values except:

Address	Value	Address	Value	Address	Value
16	15	20	12	25	0x3F or 0x00
17	15	21	8	26	0
18	15	22	1	27	0x1F
19	15	23	0x3F	30	2

### AKS Feature:

On the EVK1060A, the AKS feature is a global setting for the 6 capacitive keys. The AKS mode is changed by moving the 2-way link fitted to J1 as indicated.

- If AKS feature set to 'On' (link on Pins 1 and 2): When touching multiple keys, only the LED associated with the key with the strongest signal is lit. The Guard Channel (K5) is configured to give the strongest signal (large electrode and largest sense capacitor (C5) value)
- If set to 'Off' (link on Pins 2 and 3): When touching multiple keys, multiple LEDs will be lit.

### SW1:

Pressing SW1 demonstrates the QT1060's 7th GPIO as an input. LED6 will illuminate when SW1 is pressed.



### EVK1060A Kit Contents:

1x EVK1060A Assembly	
1x CR2032 Battery, 3V, 235mAh	
2x Sample AT42QT1060-MMU ICs	
1x EVK1060A User Guide	
Packed by:	Dated:

### Touch Technology Division

1 Mitchell Point  
Ensign Way, Hamble  
Southampton SO31 4RF  
United Kingdom  
Tel: +44 (0)23 8056 5600  
Fax: +44 (0)23 8045 3939

### QUANTUM™ RESEARCH GROUP

Copyright © 2008 QRG Ltd.  
All rights reserved  
Patented and patents pending  
[www.atmel.com](http://www.atmel.com)  
[qprox.support@atmel.com](mailto:qprox.support@atmel.com)  
REV 100.0908

