



Chipsmall Limited consists of a professional team with an average of over 10 year of expertise in the distribution of electronic components. Based in Hongkong, we have already established firm and mutual-benefit business relationships with customers from,Europe,America and south Asia,supplying obsolete and hard-to-find components to meet their specific needs.

With the principle of "Quality Parts,Customers Priority,Honest Operation,and Considerate Service",our business mainly focus on the distribution of electronic components. Line cards we deal with include Microchip,ALPS,ROHM,Xilinx,Pulse,ON,Everlight and Freescale. Main products comprise IC,Modules,Potentiometer,IC Socket,Relay,Connector.Our parts cover such applications as commercial,industrial, and automotives areas.

We are looking forward to setting up business relationship with you and hope to provide you with the best service and solution. Let us make a better world for our industry!



## Contact us

Tel: +86-755-8981 8866 Fax: +86-755-8427 6832

Email & Skype: info@chipsmall.com Web: www.chipsmall.com

Address: A1208, Overseas Decoration Building, #122 Zhenhua RD., Futian, Shenzhen, China



# EVK2160A USER GUIDE



**QUANTUM**<sup>TM</sup>  
RESEARCH GROUP

[www.atmel.com](http://www.atmel.com)



## Using the EVK2160A:

This kit is for the evaluation and development of applications using the AT42QT2160-MMU ('QT2160') 16 Key QMatrix™ Integrated Circuit (IC). In this example, the QT2160 is shown working in a battery powered 'Standalone' mode, but can be connected to a PC and/or User application by simple modifications to the EVK2160A Evaluation Board.

In this example, the QT2160 is configured with 8 individual keys plus 8 keys configured as a slider.

**Please refer to the QT2160 datasheet available at [www.atmel.com](http://www.atmel.com) for full details.**

- Ensure the EVK2160A Evaluation Board is securely located in the clear molded case.
- Insert the CR2032 3V battery provided into the battery holder on the EVK2160A.  
*Ensure that the battery has the correct orientation (negative (-) side to board) or the EVK2160A will not work.*
- The 12 LEDs will illuminate in sequence, then extinguish.
- Touch and hold the ON/OFF symbol - LED (D11) will illuminate indicating power to the QT2160. Remove touch from the ON/OFF symbol.
- Touch any of the 8 key(s) on the EVK2160A and the corresponding LED(s) will illuminate.  
*(The number of LED(s) illuminated will depend on the AKS™ setting at J1)*
- Touch and/or slide up on the slider area and the corresponding 3 LED(s) will illuminate at different intensities (using QT2160's PWM capabilities) dependant on the last reported touched position.
- Touch and hold the ON/OFF symbol - The LED (D11) will extinguish to indicating power to the QT2160 has been removed. Remove touch from the ON/OFF symbol.
- The EVK2160A will power off after approximately 3 minutes of inactivity.



# AT42QT2160-MMU

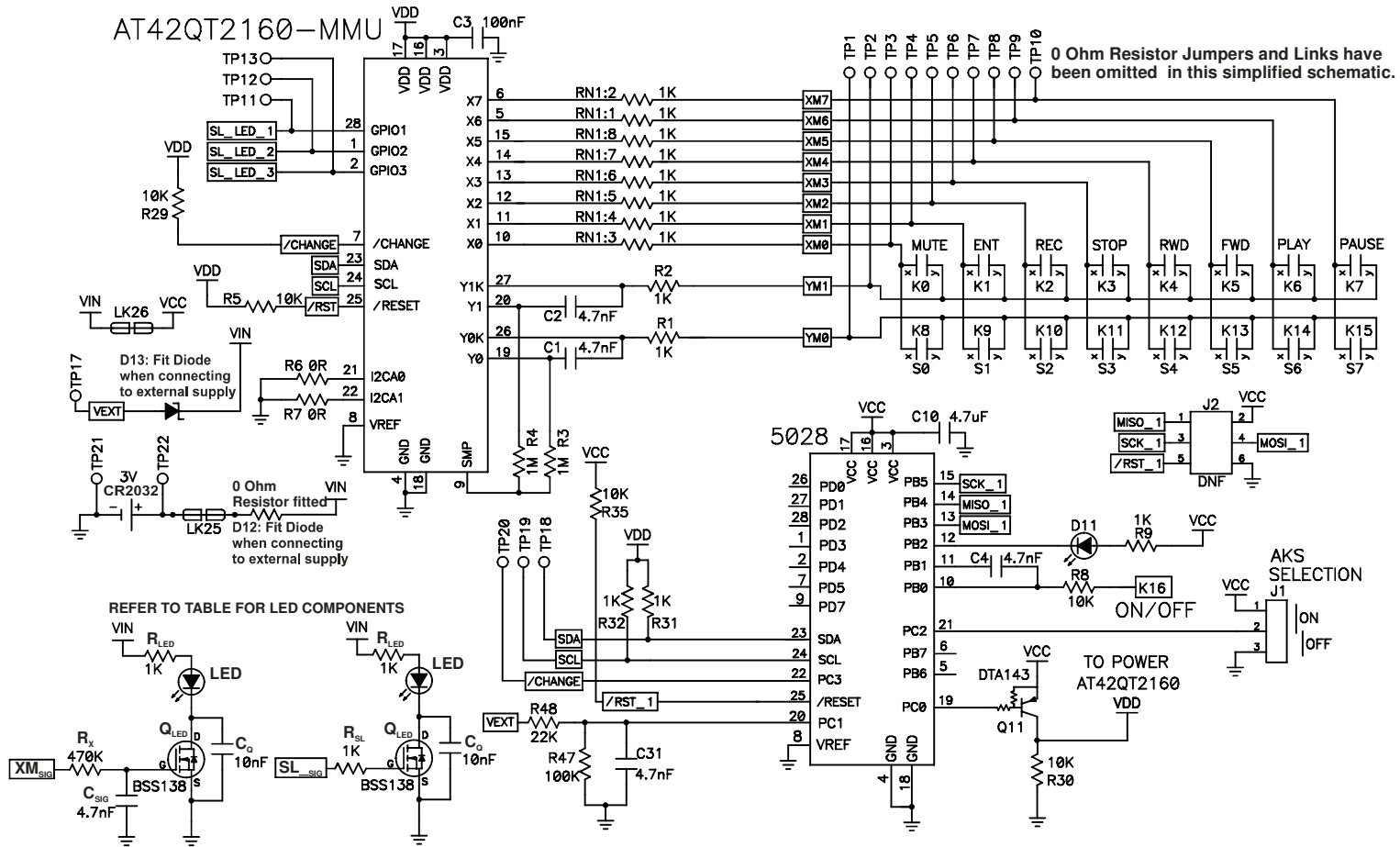

## LED Component Details:

SL_SIG	XM <sub>SIG</sub>	R <sub>SL</sub>	R <sub>X</sub>	Q <sub>LED</sub>	C <sub>Q</sub>	LED	R <sub>LED</sub>	C <sub>SIG</sub>
SL_LED_1		R38	-	Q8	C26	D8	R40	-
SL_LED_2		R41	-	Q9	C27	D9	R43	-
SL_LED_3		R44	-	Q10	C29	D9	R46	-
	XM0	-	RN2:3	Q0	C22	D0	RN3:5	C21
	XM1	-	RN2:4	Q1	C24	D1	RN3:4	C23
	XM2	-	RN2:5	Q2	C17	D2	RN3:6	C18
	XM3	-	RN2:6	Q3	C19	D3	RN3:3	C20
	XM4	-	RN2:7	Q4	C14	D4	RN3:7	C13
	XM5	-	RN2:8	Q5	C15	D5	RN3:2	C16
	XM6	-	RN2:1	Q6	C6	D6	RN3:8	C11
	XM7	-	RN2:2	Q7	C7	D7	RN3:1	C12

## 5028:

- Provides On/Off QTouch™ button, including auto power-off
- Determines whether connected to USB port/external I2C
- Sets the QT2160 through I2C: Default AT42QT2160 values (refer to datasheet) except:

Address	Value	Address	Value	Address	Value
10	0x01	22...29	0x02	70	0x00
18	0x00	30...37	0x01 or 0x00	73	0x1C
20	0xA8	38...53	0x1E	75	0x10
21	0x00	54...69	0x20	76	0x00

## **AKS™ Mode:**

On the EVK2160A, AKS™ is a global setting for the 8 individual keys. The AKS™ mode is changed by moving the 2-way link fitted to J1 as indicated.

- If set to 'On' (link on Pins 1 and 2): When touching multiple keys, only the LED associated with the key with the strongest signal is lit.
- If set to 'Off' (link on Pins 2 and 3): When touching multiple keys, all associated LEDs will be lit.

## **External Keyboard/Electrodes:**

The EVK2160A can be connected to User electrodes, using pads X0-X7 and Y0, Y1, and cutting the associated 10 tracks adjacent to keys K8-K15. Slide the EVK2160A out of the molded case to access the component side of the board.

## **Input/Output:**

The EVK2160A can be connected to User applications through I2C, using /CHG, SCL, SDA pads.

Three dedicated General Purpose Inputs/Outputs (GPIO's) are available at the pads connected to Pins 1, 2 and 28 of the QT2160.

## **Power Supply:**

An external power supply can be used instead of the supplied battery, but ensure that Schottky diodes are fitted to D12 and D13 to prevent cross powering of USB and battery sources.

It is advised to remove the battery when using an external power supply.

## Troubleshooting:

Problem	Potential Solution
<b>EVK2160A does not work</b>	<p>If the Power LED is off, the Auto Power off timeout may have been exceeded. Touch ON/OFF to restore power.</p> <p>If using a battery, check that the negative (-) side is facing the board.</p> <p>Check/replace battery.</p> <p>If using an external power supply, check that the correct connections have been made, and D12 and D13 have been fitted correctly.</p>
<b>LED(s) stuck on</b>	<p>Ensure the EVK2160A Evaluation Board is mechanically stable. Movements relative to its surrounding can affect key reference values.</p>
<b>LED(s) Flash/Erratic behaviour</b>	<p>Check battery condition. Old batteries can cause voltage drops which will affect the performance of the QT2160.</p> <p>Do not touch any of the tracks close to the QT2160 (on either side of the PCB), as this will affect the capacitive signals.</p>



## EVK2160A Kit Contents:

<b>1x EVK2160A Assembly</b> (EVK2160A Evaluation Board in molded box)			
<b>1x CR2032 Battery, 3V, 235mAh</b>			
<b>2x Sample AT42QT2160-MMU ICs</b>			
<b>1x EVK2160A User Guide</b>		✓	
<i>Packed by:</i>		<i>Dated:</i>	

### Touch Technology Division

1 Mitchell Point  
Ensign Way, Hamble  
Southampton SO31 4RF  
United Kingdom  
Tel: +44 (0)23 8056 5600  
Fax: +44 (0)23 8045 3939

### QUANTUM<sup>TM</sup> RESEARCH GROUP

Copyright © QRG Ltd.  
All rights reserved  
Patented and patents pending  
[www.atmel.com](http://www.atmel.com)  
[qprox.support@atmel.com](mailto:qprox.support@atmel.com)  
REV 103.0708

