



Chipsmall Limited consists of a professional team with an average of over 10 year of expertise in the distribution of electronic components. Based in Hongkong, we have already established firm and mutual-benefit business relationships with customers from,Europe,America and south Asia,supplying obsolete and hard-to-find components to meet their specific needs.

With the principle of “Quality Parts,Customers Priority,Honest Operation,and Considerate Service”,our business mainly focus on the distribution of electronic components. Line cards we deal with include Microchip,ALPS,ROHM,Xilinx,Pulse,ON,Everlight and Freescale. Main products comprise IC,Modules,Potentiometer,IC Socket,Relay,Connector.Our parts cover such applications as commercial,industrial, and automotives areas.

We are looking forward to setting up business relationship with you and hope to provide you with the best service and solution. Let us make a better world for our industry!



Contact us

Tel: +86-755-8981 8866 Fax: +86-755-8427 6832

Email & Skype: info@chipsmall.com Web: www.chipsmall.com

Address: A1208, Overseas Decoration Building, #122 Zhenhua RD., Futian, Shenzhen, China



Constant current inverse buck LED driver using L6562A

Introduction

Whenever a lighting application, such as street lighting for example, requires an elevated number of LEDs, there are basically two solutions: the first is to connect all the diodes in series in a single "string"; the second is to place several strings in parallel with fewer elements in each one.

The first solution, even if simpler, poses stringent safety requirements due to the high supply voltage. The latter needs a lower input voltage but the current through each string has to be independently controlled.

Since, from a system point of view, the second solution seems more viable, we have developed an application to investigate the possibility of employing an L6562A to implement such a constant current controller. This document describes the EVL6562A-LED demonstration board and summarizes the relevant results obtained.

Figure 1. EVL6562A-LED: L6562A constant current inverse buck driver module

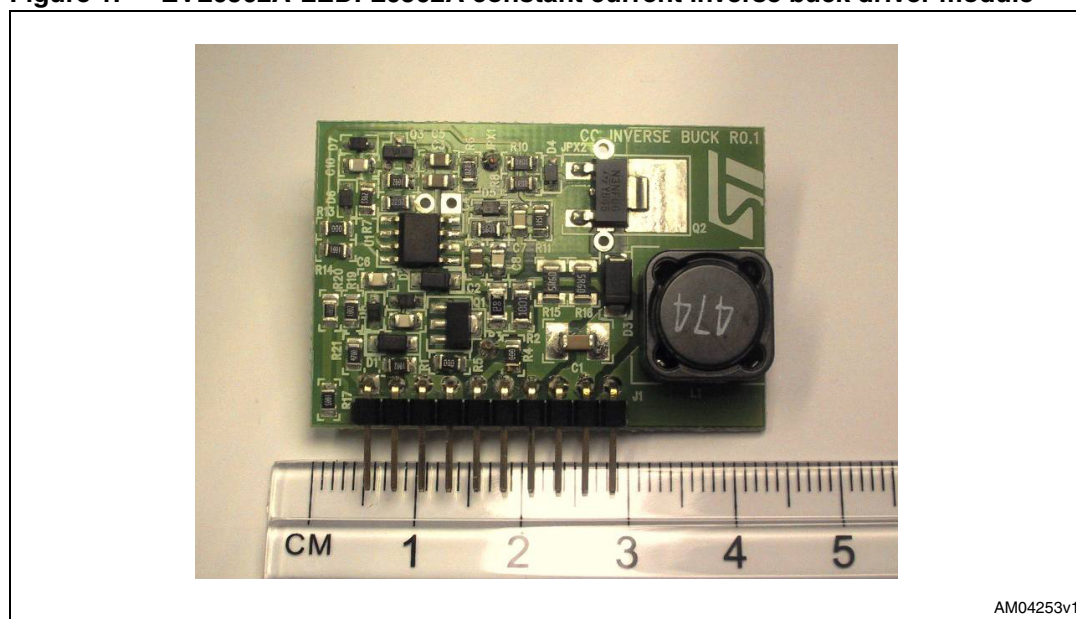

Contents

1	Main characteristics	4
1.1	System configuration	4
1.2	Requirements	4
1.3	Interface	5
2	Circuit description	6
2.1	Power section	6
2.2	L6562A controller	8
2.3	FOT (fixed off time) delay circuit	9
2.4	Current setting	11
2.5	LED number compensation	15
2.6	Shutdown/dimming	18
2.7	Auxiliary power	21
2.8	Open-/short-circuit protection	22
3	Measurements	24
3.1	LED voltage dependency	24
3.2	Input voltage dependency	26
4	Electrical schematic and bill of materials	27
5	References	30
6	Revision history	31

List of figures

Figure 1.	EVL6562A-LED: L6562A constant current inverse buck driver module	1
Figure 2.	System configuration	4
Figure 3.	Module schematic	6
Figure 4.	Standard buck converter.	7
Figure 5.	Inverse buck converter	7
Figure 6.	Controller diagram	8
Figure 7.	Simulated waveforms	9
Figure 8.	FOT net.	9
Figure 9.	toff delay (actual)	10
Figure 10.	toff delay (nominal)	11
Figure 11.	Current setting	11
Figure 12.	I _{Led} /V _{trim}	15
Figure 13.	I _{Led} /V _{Led}	18
Figure 14.	Enable/dimming detailed view (turn-on)	19
Figure 15.	Enable/dimming detailed view (turn-off)	19
Figure 16.	Dimming 1%	20
Figure 17.	Dimming 10%	20
Figure 18.	Dimming 50%	20
Figure 19.	Dimming 90%	21
Figure 20.	Dimming 99%	21
Figure 21.	Auxiliary power	21
Figure 22.	Short-circuit protection	22
Figure 23.	Short-circuit application	23
Figure 24.	Short-circuit removal	23
Figure 25.	Short-circuit detection	23
Figure 26.	Load current decay	23
Figure 27.	LED current (average, maximum, minimum)	24
Figure 28.	LED current (ripple)	24
Figure 29.	Switching frequency	25
Figure 30.	Efficiency [%]	25
Figure 31.	LED current (average)	26
Figure 32.	Switching frequency	26
Figure 33.	Efficiency [%]	26
Figure 34.	EVL6562A-LED electrical schematic	27

1 Main characteristics

1.1 System configuration

Figure 2 shows a possible system configuration, in which the key modules are:

- the main power supply, which converts the AC input voltage to an internal power bus.
- the CC drivers, which are the modules that implement the constant current sources.
- the controller that configures the CC current drivers through a dedicated bus.
- the LEDs strings.

The CC drivers are the modules considered in this application note and implemented in the EVL6562A-LED demonstration board.

Figure 2. System configuration

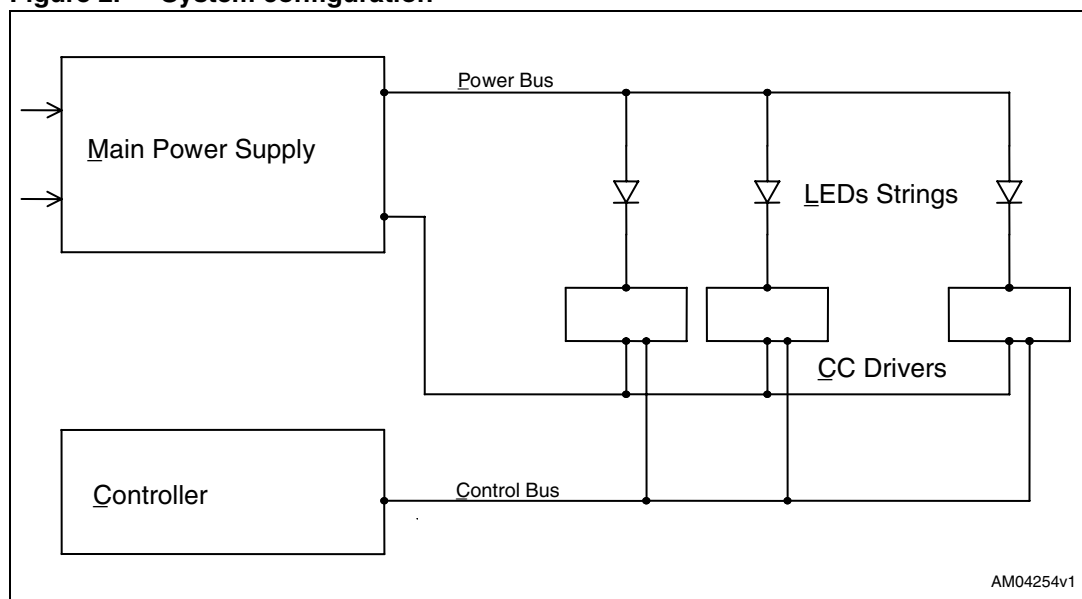

1.2 Requirements

The board's design takes into account the following key points.

- Input voltage: 48 V (+/- 20%)
- Output current (average): 0.35 A
- Output ripple current < 140 mA (+/- 20%)
- Output current setting/calibration
- Digital dimming
- Open-/short-circuit protection
- Absence of electrolytic capacitors

The design can be easily changed to adapt to different needs.

1.3 Interface

Ideally the module should have only two pins and behave as a constant current sink, but for practical reasons, and in order to gain a higher degree of flexibility, its connector has the following pinout.

Table 1. EVL6562A-LED interface

Pin number	Signal name	Connection	Notes
1	D_Dimm	Shutdown / digital dimming	Digital input
2	C_Set	Load current setting	0.. 12 V input
3	Gnd	Auxiliary power (Gnd)	
4	Gnd	Auxiliary power (Gnd)	
5	Vcc	Auxiliary power (Vcc)	(18 V) input/output
6	n.c.		
7	Vin_Gnd	Main power (Gnd)	
8	Vin	Main power (Vin)	(48 V nom.) input
9	LEDs_A	LEDs anode Interconnection	Output
10	LEDs_K	LEDs cathode interconnection	Output

- D_Dimm is a digital (TTL) input for the module. A high level shuts off the circuit. A low level enables the nominal load current and a square wave with variable duty cycle can be used as a dimming control
- C_Set is an analog input (0...12 V). A voltage applied to this pin is used to set the load current to the required value
- Gnd pins 3 and 4 are the ground return for the controller's power supply (Vcc). D_Dimm and C_set are referred to this ground
- Vcc is the connection to the controller's power supply input
- Vin_Gnd is the main power supply return, internally connected to the Gnd pins
- Vin is the main power supply input (48 V)
- LEDs_A is the connection to the anode of the diode string
- LEDs_K is the connection to the cathode of the diode string

2 Circuit description

The following is a list of the main components that form the module EVL6562A-LED.

- Power section
- L6562A controller
- Fixed off time (FOT) delay
- Current setting
- LED number compensation
- Shutdown/dimming
- Auxiliary power
- Open-/short-circuit protection

Figure 3. Module schematic

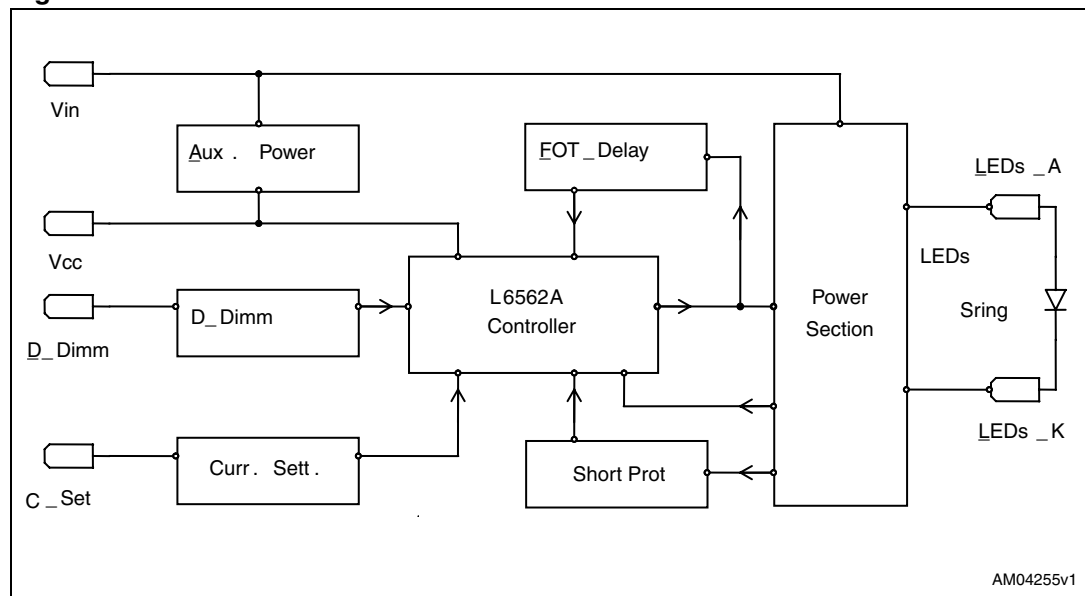

2.1 Power section

The topology of this stage is the so-called inverse buck (also referred to as modified or low-side buck). Simply stated, it is a standard buck converter with the power and ground connections interchanged, as shown in [Figure 4](#) and [Figure 5](#).

Figure 4. Standard buck converter

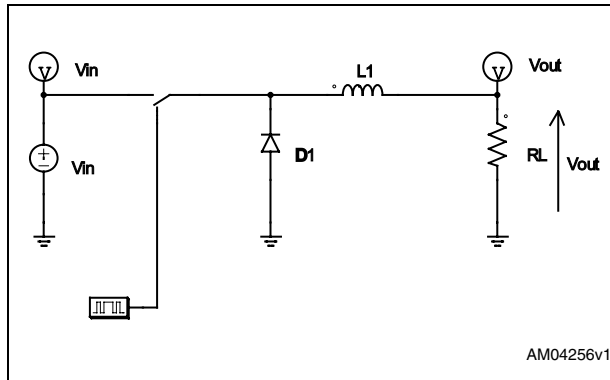
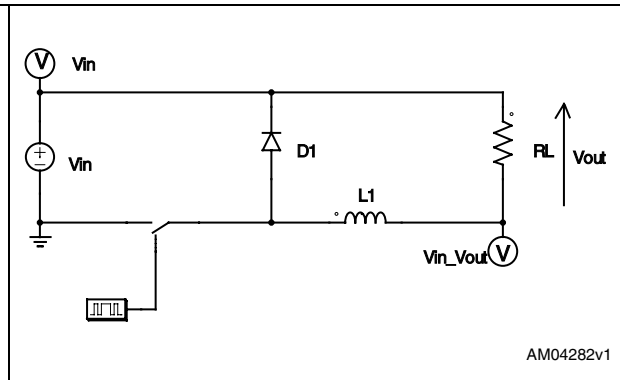

Figure 5. Inverse buck converter



Other than the power and ground connections being exchanged, there are no differences between the two configurations; the behavior and dimensioning of the inverse buck are the same as that of the standard buck. Refer to application note AN2928^(a) for a detailed description and design rules. The following are a reminder of the fundamental applicable equations.

Inductor current variation (charging period)

Equation 1

$$\Delta I_{\text{ton}} = \left[\frac{V_{\text{in}} - V_{\text{Led}}}{L} \right] * \text{ton}$$

Inductor current variation (discharging period)

Equation 2

$$\Delta I_{\text{toff}} = \left[\frac{V_{\text{Led}}}{L} \right] * \text{toff}$$

The circuit works in continuous conduction mode, then in steady-state the current variations during *ton* and *toff* are the same (in module) and equivalent to the ripple current I_{rip} .

Ripple current

Equation 3

$$I_{\text{rip}} = |\Delta I_{\text{ton}}| = |\Delta I_{\text{toff}}|$$

Duty cycle

Equation 4

$$D = \left[\frac{\text{ton}}{T} \right] = \left[\frac{V_{\text{Led}}}{V_{\text{in}}} \right]$$

Additionally, the average current of the LED can be expressed as:

a. See [Chapter 5: References on page 30](#).

Equation 5

$$I_Led_avg = I_Led_pk - \frac{1}{2}I_rip$$

Equation 6

$$I_Led_avg = I_Led_pk - \frac{1}{2} \left[\frac{VLed}{L} \right] * toff$$

2.2 L6562A controller

The L6562A is used in a "fixed off time" and "peak current mode" topology. [Figure 6](#) represents the controller with its main functional blocks, the FOT_Delay circuitry and the power section.

Figure 6. Controller diagram

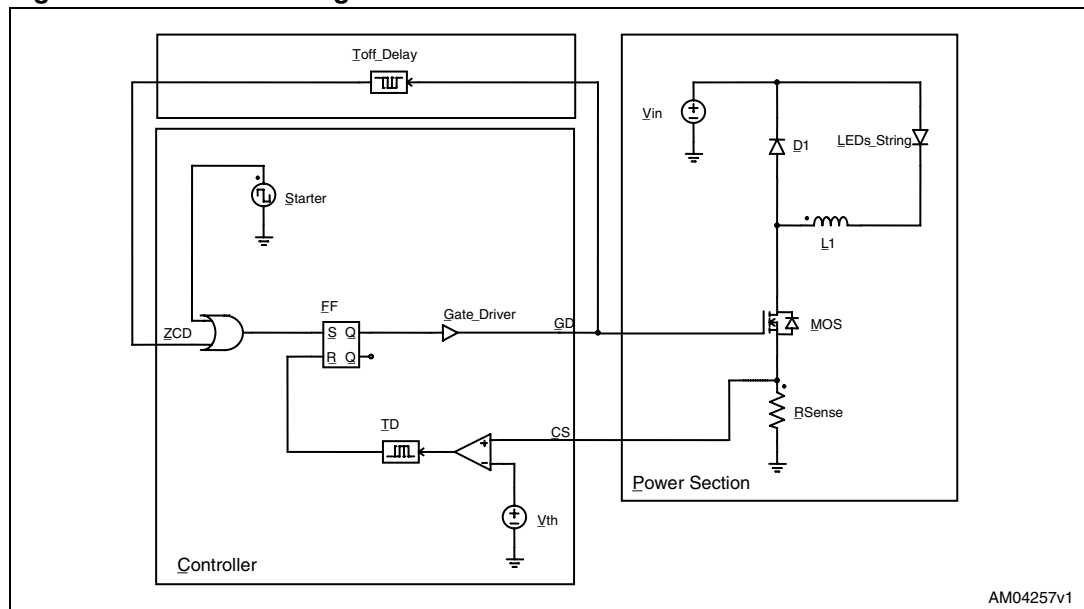

At power-on, the "starter" sets the flip-flop, whose output (Q) goes high activating the gate driver (GD).

The power MOSFET transistor is turned on and the load current (I_Led) flows through the LED diodes, inductor, power MOSFET transistor and sense resistor.

The load current develops a voltage on the sense resistor: $V_S = I_Led * R_{Sense}$.

This voltage is applied to the CS input of the controller where it is compared to the reference voltage $V_{th} = 1.08\text{ V}$ (nom.)

When V_S becomes higher than V_{th} , the comparator's output goes high, activating the reset input of the FF.

The FF Q output is set to low and the gate driver output voltage goes to gnd.

The power MOSFET is turned off, V_S goes to zero and the I_Led current decreases, flowing through the LEDs, inductor and Flywheel diode.

The falling edge of the gate driver starts the *toff* delay (see [Section 2.3 on page 9](#)). At the end of the *toff* delay the set input of the FF is activated and a new cycle begins.

Figure 7. Simulated waveforms

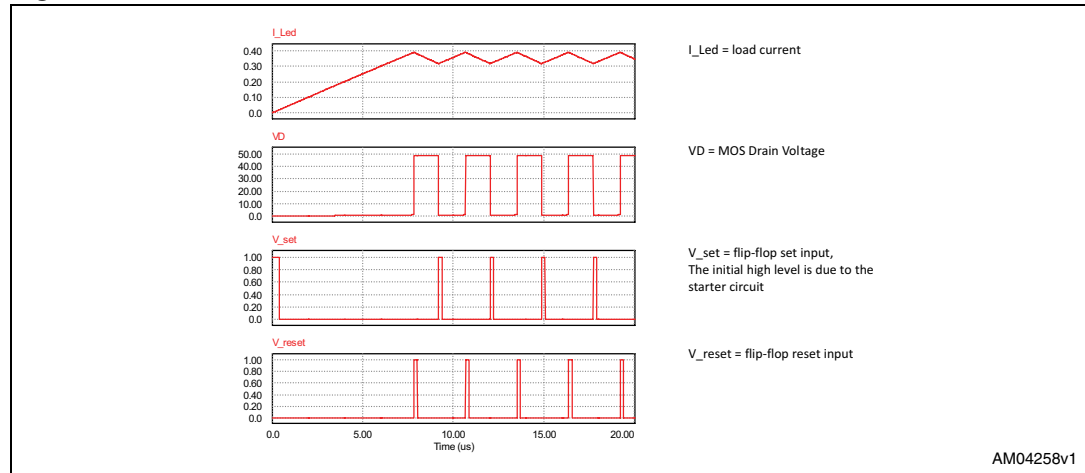

2.3 FOT (fixed off time) delay circuit

Figure 8. FOT net

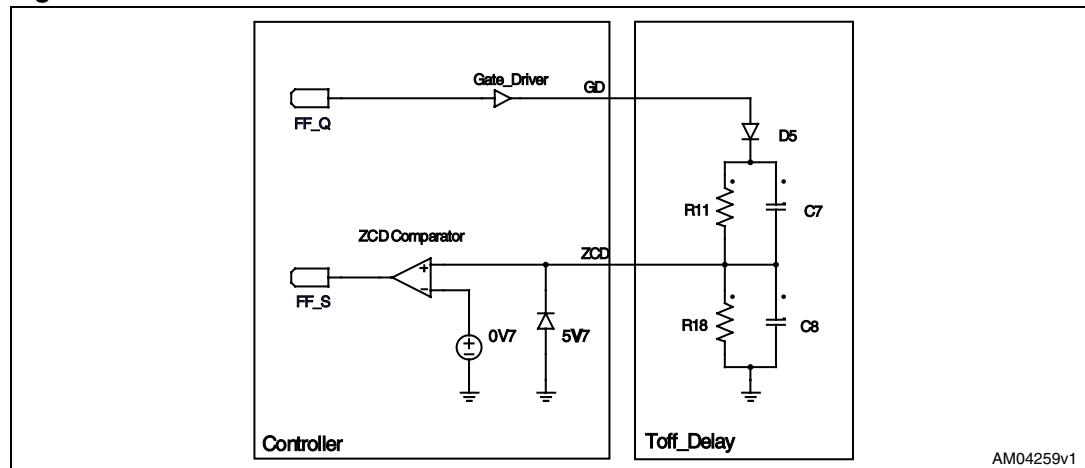

The fixed off time delay circuit is implemented by connecting the gate drive (GD) output to the ZCD input by means of a diode D5 in series with R11 and C7 (in parallel), and ZCD to ground with R18 and C8 in parallel.

There is a clamp circuit behind the ZCD pin of the controller that limits the maximum voltage to 5.7 V, and a comparator whose output goes high if the input voltage falls below the threshold level of 0.7 V.

Hence when GD is high (10 V nominal), ZCD is forced to the clamp level of 5.7 V, but as soon as the gate driver goes low, the diode D5 turns off and the capacitor C8 discharges through R18 until the voltage reaches 0.7 V.

At this point the comparator switches on and triggers the set input of the flip-flop, whose output goes high.

This causes the gate driver to go high again and then the power MOSFET to conduct.

The time delay *toff* is simply governed by the equation of the discharge of the capacitor C8 through the resistor R18 with the boundary conditions $V(t_0) = 5.7\text{ V}$, $V(t_1) = 0.7\text{ V}$.

Equation 7

$$V(t_1) = V(t_0) * e^{-\left[\frac{\text{toff}}{R_{18} * C_8}\right]}$$

Equation 8

$$\ln\left[\frac{V(t_1)}{V(t_0)}\right] = -\left[\frac{\text{toff}}{R_{18} * C_8}\right]$$

Equation 9

$$\text{toff} = (R_{18} * C_8) * \ln\left[\frac{V(t_0)}{V(t_1)}\right]$$

With our values this gives:

Equation 10

$$\text{toff} = (R_{18} * C_8) * \ln\left[\frac{5.7}{0.7}\right] = 2.1 * (R_{18} * C_8) = 1.17\mu\text{S}$$

Refer to AN2782^(b) for a detailed description of the FOT controller. [Figure 9](#) shows the key waveforms with the LEDs' current (*I_LED*), capacitor (C8) voltage (*V_C8*) and gate drive output voltage (*V_GD*).

Figure 9. toff delay (actual)

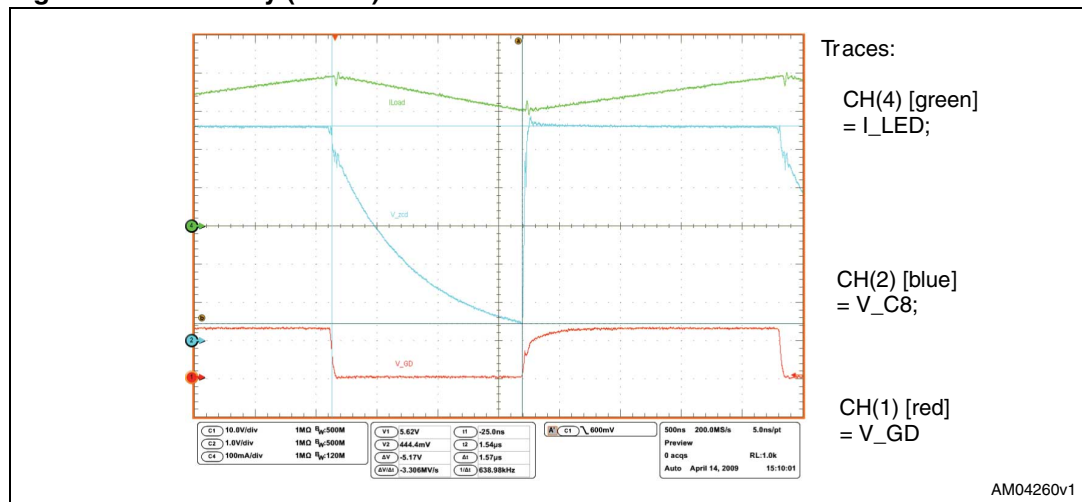

It is worth noting that the real *toff* time is 1.57 μs and that the low threshold is 0.44 V. This is due to the components' tolerance and to the propagation delay from the comparator input to the gate driver output.

b. See [Chapter 5: References on page 30](#).

If we consider the time at which the capacitor voltage crosses the 0.7 V threshold, the equivalent *toff* time is 1.32 μ S (+150 nS compared to the nominal value, due to the tolerance of C8 and stray capacitance) while the remaining 250 nS are related to the propagation delay (during which the voltage falls from 0.7 V to 0.44 V).

Figure 10. *toff* delay (nominal)

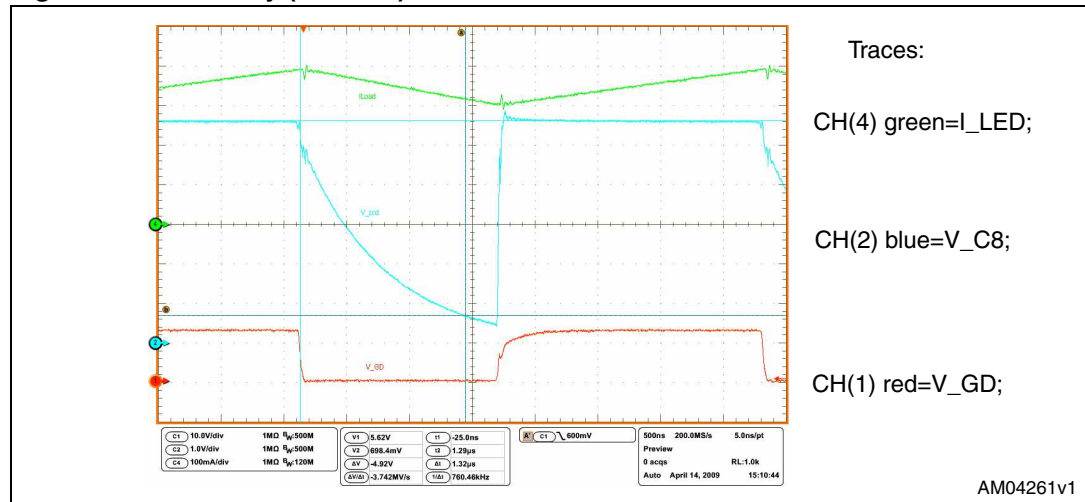

2.4 Current setting

As already indicated, the CS pin of the L6562A controller is internally connected to the non-inverting input of the CS comparator, whose threshold (V_{th}) is fixed to 1.08 V (nom.)

Tying it to the sense resistor forces the comparator’s output high when $I_{Led} = V_{th} / R_S$.

This is a very simple way to detect – and limit – the peak load current to a fixed value.

In order to make this value adjustable, we can introduce an auxiliary voltage source (V_a), connected to the CS pin through a resistor (R_a) and another resistor (R_b) between CS and the sense resistor, as indicated in [Figure 11](#). In this way the auxiliary source can be used to modify the threshold at which the (peak) load current triggers the comparator.

Figure 11. Current setting

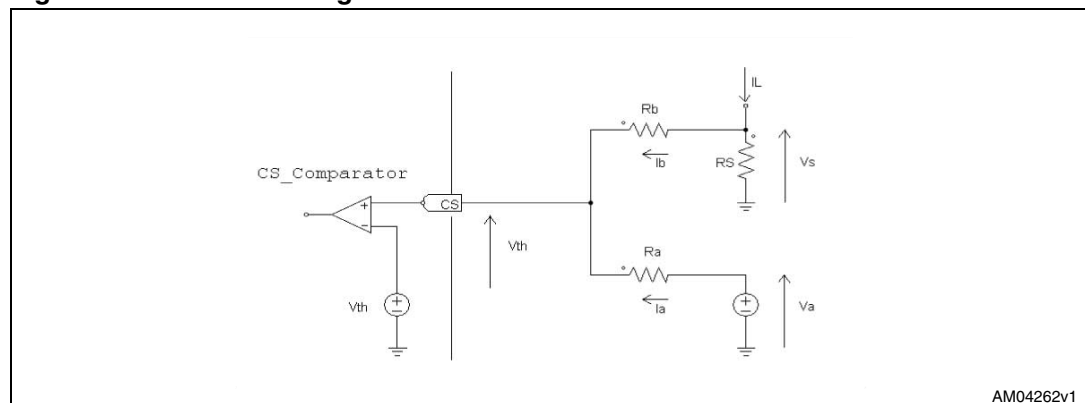

Equation 11

$$V_{th} = V_s - I_b * R_b$$

Equation 12

$$V_{th} = V_a - I_a * R_a$$

Neglecting the current that flows through the CS pin (1 μ A max):

Equation 13

$$I_b = -I_a$$

And then:

Equation 14

$$V_{th} = V_s - I_b * R_b$$

Equation 15

$$V_{th} = V_a + I_b * R_a$$

Then:

Equation 16

$$V_s = V_{th} + I_b * R_b$$

and:

Equation 17

$$I_b = \left(\frac{1}{R_a} \right) * (V_{th} - V_a)$$

Equation 18

$$V_s = V_{th} + \left(\frac{1}{R_a} \right) * (V_{th} - V_a) * R_b$$

Equation 19

$$V_s = V_{th} + \left(\frac{R_b}{R_a} \right) * V_{th} - \left(\frac{R_b}{R_a} \right) * V_a$$

Equation 20

$$V_s = V_{th} * \left(\frac{R_a + R_b}{R_a} \right) - V_a * \left(\frac{R_b}{R_a} \right)$$

Equation 21

$$I_{Led_pk} = \left(\frac{1}{R_s} \right) * \left[V_{th} * \left(\frac{R_a + R_b}{R_a} \right) - V_a * \left(\frac{R_b}{R_a} \right) \right]$$

If we consider the limit condition $V_a = 0$, which is equivalent to connecting R_a directly to ground, the maximum peak LED current I_{Led_pk} (max) can be obtained by:

Equation 22

$$I_{\text{Led_pk(max)}} = I_{\text{Led_pk(nom)}} * \left(\frac{R_a + R_b}{R_a} \right)$$

Where, as already seen, the (nominal) LED peak current is:

Equation 23

$$I_{\text{Led_pk(nom)}} = \left(\frac{1}{R_s} \right) * V_{\text{th}}$$

On the other hand, if we fix $I_{\text{Led_pk}} = 0$ we can estimate the value of V_a for which the LED current is reduced to zero.

Equation 24

$$0 = \left(\frac{1}{R_s} \right) * \left[V_{\text{th}} * \left(\frac{R_a + R_b}{R_a} \right) - V_a * \left(\frac{R_b}{R_a} \right) \right]$$

Equation 25

$$V_a * \left(\frac{R_b}{R_a} \right) = V_{\text{th}} * \left(\frac{R_a + R_b}{R_a} \right)$$

Equation 26

$$V_a = V_{\text{th}} * \left(\frac{R_a + R_b}{R_b} \right)$$

With our values of $R_a = R_{19} = 10 \text{ k}\Omega$, and $R_b = R_{14} = 1 \text{ k}\Omega$, [Equation 21](#) can be rewritten as:

Equation 27

$$I_{\text{Led_pk}} = \left(\frac{1}{R_s} \right) * [(1.1) * V_{\text{th}} - (0.1) * V_a]$$

[Equation 22](#) becomes:

Equation 28

$$I_{\text{Led_pk(max)}} = I_{\text{Led_pk(nom)}} * (1.1)$$

And [Equation 25](#):

Equation 29

$$V_a = V_{\text{th}} * (11)$$

In the plot shown in [Figure 12](#) the LED current (I_{Led}) is expressed as a function of the trim voltage V_{trim} (= V_a) applied at the C_{set} module input, with the supply voltage (V_{in}) as parameter (fixed at 36, 48 and 60 V).

As you can see, the linearity is quite good for currents in the range of 400 to 75 mA and voltages in the range 0... 10 V, while with V_{trim} from 10 to 12 V the current still decreases down to zero, but with some non-linearity.

This is due to the fact that the LED diodes are a non-linear load and their behavior at low current levels may change from one device to another.

Another point that has to be taken into account is that when the average current is reduced, the minimum LED current is reduced to zero, causing the converter to change from continuous conduction mode (CCM) to discontinuous conduction mode (DCM) operation.

Figure 12. I_Led/V_trim

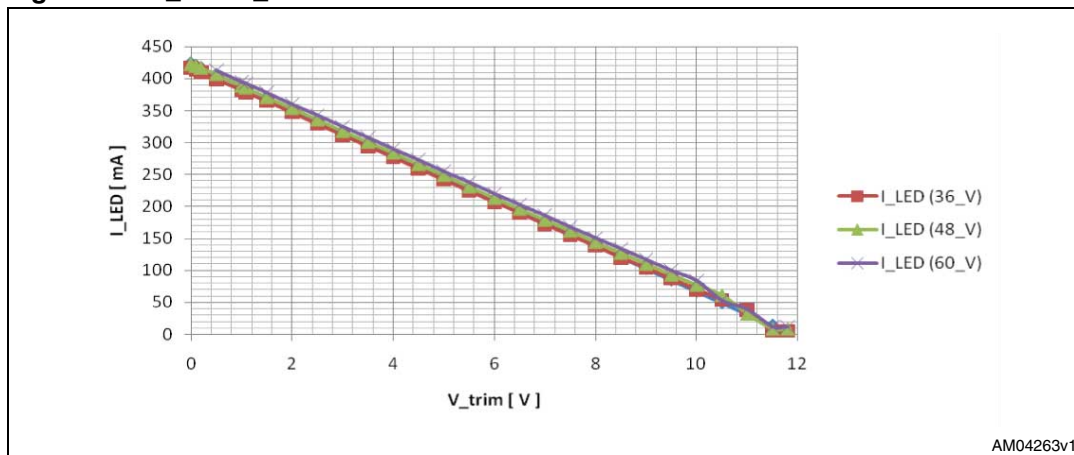

2.5 LED number compensation

The average output current depends on the number of LEDs connected to the module, or to be more precise, on the voltage (V_{Led}) developed across them. This is due to the fact that:

Equation 30

$$I_Led_avg = I_Led_pk - \frac{1}{2}I_rip$$

and:

Equation 31

$$I_rip = \left(\frac{toff}{L}\right) * VLed$$

and then:

Equation 32

$$I_Led_avg = I_Led_pk - \frac{1}{2}\left(\frac{toff}{L}\right) * VLed$$

With a constant I_{Led}_{pk}, toff and L, it appears that if V_{Led} increases, the average current decreases, and vice versa.

Usually the number of LEDs is determined in the early stages of the design phase, but if required, it is possible to make the load current almost independent of the number of LEDs employed by connecting two resistors (R17 and R20) from the LEDs' cathode to the CS pin of the controller.

With a technique similar to that of the current setting, the circuit senses the voltage [V_{in} - V_{Led}] that depends on the number of LEDs and corrects the voltage applied to the current sense pin.

In this way the circuit behaves as if the internal comparator triggers when the average current – instead of the peak current – exceeds the threshold value.

The drawback of this configuration is that since the circuit is now more sensitive to input voltage variations, V_{in} has to be more tightly regulated.

The following equations demonstrate what has been previously asserted.

Equation 33

$$I_{Led_avg} = I_{Led_pk} - \frac{1}{2} \left(\frac{toff}{L} \right) * VLed$$

Equation 34

$$I_{Led_pk} = \left(\frac{1}{R_s} \right) * \left[V_{th} * \left(\frac{R_a + R_b}{R_a} \right) - V_a * \left(\frac{R_b}{R_a} \right) \right]$$

Where: I_{Led_avg} is the LEDs' average current, I_{Led_pk} is the LEDs' peak current and $V_a = (V_{in} - VLed)$ is the LEDs' cathode voltage.

Equation 35

$$I_{Led_avg} = \left(\frac{1}{R_s} \right) * \left[V_{th} * \left(\frac{R_a + R_b}{R_a} \right) - (V_{in} - VLed) * \left(\frac{R_b}{R_a} \right) \right] - \frac{1}{2} \left(\frac{toff}{L} \right) * VLed$$

Equation 36

$$I_{Led_avg} = \left(\frac{1}{R_s} \right) * \left[V_{th} * \left(\frac{R_a + R_b}{R_a} \right) - V_{in} * \left(\frac{R_b}{R_a} \right) \right] + VLed * \left[\left(\frac{1}{R_s} \right) * \left(\frac{R_b}{R_a} \right) - \frac{1}{2} \left(\frac{toff}{L} \right) \right]$$

To make I_{Led_avg} independent of $VLed$, the $VLed$ coefficient has to be reduced to zero.

Equation 37

$$\frac{1}{R_s} * \left(\frac{R_b}{R_a} \right) - \frac{1}{2} \left(\frac{toff}{L} \right) = 0$$

That is to say, setting:

Equation 38

$$\left(\frac{R_b}{R_a} \right) = \frac{1}{2} \left(\frac{toff}{L/R_s} \right) = 0$$

reduces [Equation 36](#) to:

Equation 39

$$I_{Led_avg} = \left(\frac{1}{R_s} \right) * \left[V_{th} * \left(\frac{R_a + R_b}{R_a} \right) - (V_{in}) * \left(\frac{R_b}{R_a} \right) \right]$$

In other words, connecting R_a to the cathode of the LEDs' string, the average LED current depends only on V_{th} and V_{in} .

Going into further detail, we also have to consider the delay of the current sense comparator (t_{del}) and modify [Equation 33](#) as follows.

Equation 40

$$I_{\text{Led_avg}} = I_{\text{Led_pk}} - \frac{1}{2}I_{\text{rip}} + I_{\text{del}}$$

With:

Equation 41

$$I_{\text{del}} = \left(\frac{t_{\text{del}}}{L}\right) * (V_{\text{in}} - V_{\text{Led}})$$

Equation 42

$$I_{\text{Led_avg}} = \left(\frac{1}{R_s}\right) * \left[V_{\text{th}} * \left(\frac{R_a + R_b}{R_a}\right) - V_{\text{in}} * \left(\frac{R_b}{R_a}\right) \right] + V_{\text{in}} * \left(\frac{t_{\text{del}}}{L}\right) + V_{\text{Led}} * \left[\left(\frac{1}{R_s}\right) * \left(\frac{R_b}{R_a}\right) - \frac{1}{2} \left(\frac{t_{\text{off}}}{L}\right) \right] - V_{\text{Led}} * \left(\frac{t_{\text{del}}}{L}\right)$$

Equation 43

$$I_{\text{Led_avg}} = \left(\frac{1}{R_s}\right) * \left[V_{\text{th}} * \left(\frac{R_a + R_b}{R_a}\right) - V_{\text{in}} * \left[\left(\frac{R_b}{R_a}\right) - \left(\frac{t_{\text{del}}}{L/R_s}\right) \right] \right] + V_{\text{Led}} * \left[\left(\frac{1}{R_s}\right) * \left(\frac{R_b}{R_a}\right) - \frac{1}{2} \left(\frac{t_{\text{off}}}{L}\right) - \left(\frac{t_{\text{del}}}{L}\right) \right]$$

And with [Equation 38](#) that now becomes:

Equation 44

$$\left(\frac{R_b}{R_a}\right) = \frac{1}{2} \left(\frac{t_{\text{off}}}{L/R_s}\right) + \left(\frac{t_{\text{del}}}{L/R_s}\right)$$

And [Equation 40](#):

Equation 45

$$I_{\text{Led_avg}} = \left(\frac{1}{R_s}\right) * \left[V_{\text{th}} * \left(\frac{R_a + R_b}{R_a}\right) - V_{\text{in}} * \left[\left(\frac{R_b}{R_a}\right) - \left(\frac{t_{\text{del}}}{L/R_s}\right) \right] \right]$$

With the values of our application:

Equation 46

$$t_{\text{off}} = 1.57 \mu\text{S}, t_{\text{del}} = 0.2 \mu\text{S}, L = 470 \mu\text{H}, R_s = 2.8 \Omega$$

Equation 47

$$\left(\frac{L}{R_s}\right) = \left(\frac{470 * 10^{-6}}{2.8}\right) = (1.68 * 10^{-4}) \text{S}$$

Equation 48

$$\frac{1}{2}(t_{\text{off}}) + (t_{\text{del}}) = (0.985 * 10^{-6}) \text{S}$$

And then:

Equation 49

$$\left(\frac{R_a}{R_b}\right) = \frac{(1.68 * 10^{-4})}{(0.985 * 10^{-6})} = 170$$

On the demonstration board several measures have been taken with $V_{in} = 48 \text{ V}$, and $R_b = 1 \text{ k}\Omega$.

[Figure 13](#) is the plot of the LED current as a function of the voltage on the LED string (V_{Led}) with R_a (actually $R_{17} + R_{20}$) as a parameter.

Figure 13. I_{Led}/V_{Led}

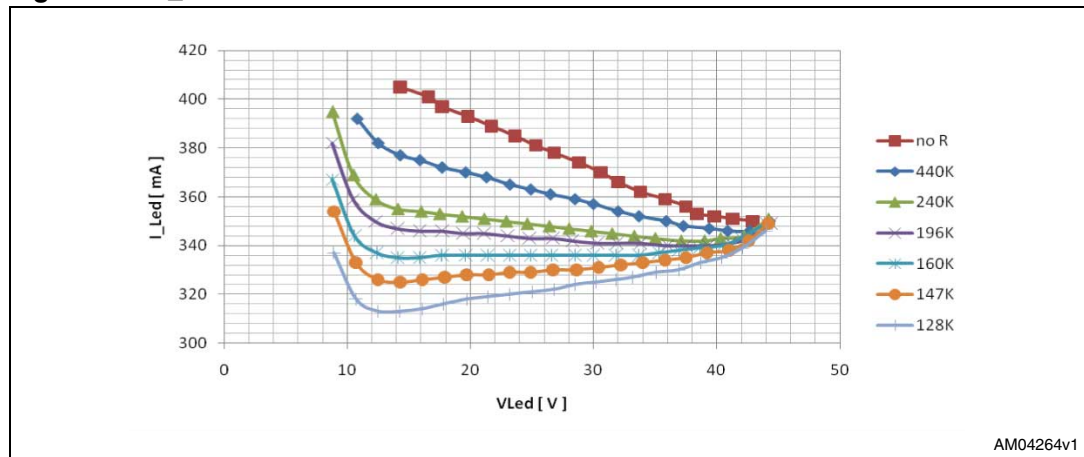

2.6 Shutdown/dimming

The D_Dim input (pin 1 of the J1 connector) has a dual function.

- Module enable
- Digital (PWM) dimming

Forcing it low, or leaving it floating, enables the controller's normal activity (current sink), while pulling it high ($> 2.7 \text{ V}$) causes the module to shut down. Therefore, this input can be used to switch the load on and off.

[Figure 14](#) and [Figure 15](#) highlight the turn-on and turn-off with an input voltage (V_{in}) of 48 V and an equivalent output voltage (V_{Led}) of 20 V . In these conditions, the rise and fall times of the load current are lower than $10 \mu\text{s}$.

Applying a square wave to this pin forces the module to 'work and stop' at the input signal frequency; in this way the average load current can be modified by simply changing the duty cycle of the PWM control.

Supposing a dimming frequency of 200 Hz is used, and taking into account the $10 \mu\text{s}$ of rise/fall time of the LED current, we can estimate the minimum dimming as $(20 \mu\text{s}) * (200 \text{ Hz}) = 0.4\%$.

[Figure 16](#), [17](#), [18](#), [19](#), and [20](#) show the LED current for different dimming factors between 1% and 99%.

Note: *R1 = 10 kΩ, C9 = 100 pF, and D1= 5.6 V Zener diode. All these devices have been introduced to protect the controller from excessive input voltages or noise; in a complete system, with a driver directly connected, they can be avoided.*

Figure 14. Enable/dimming detailed view (turn-on)

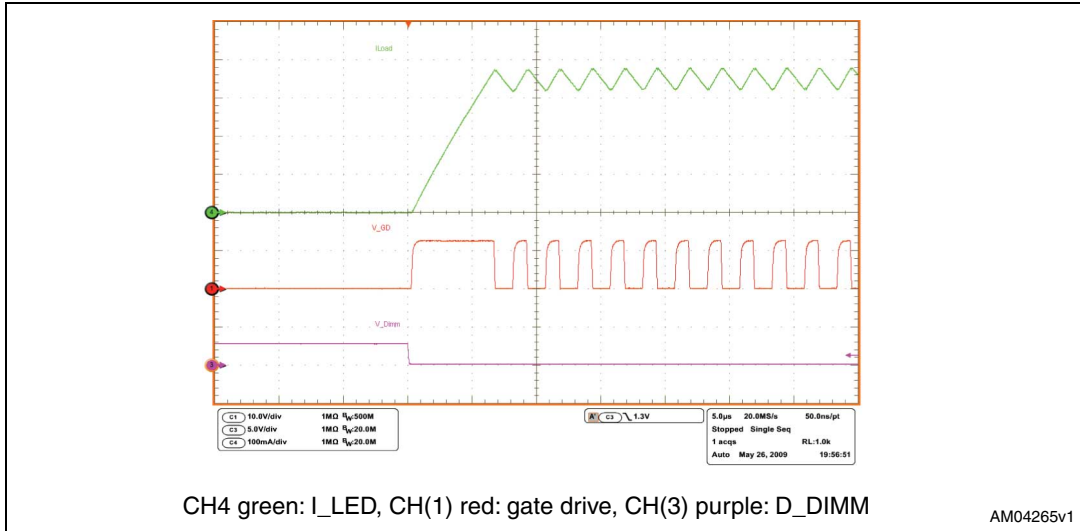

Figure 15. Enable/dimming detailed view (turn-off)

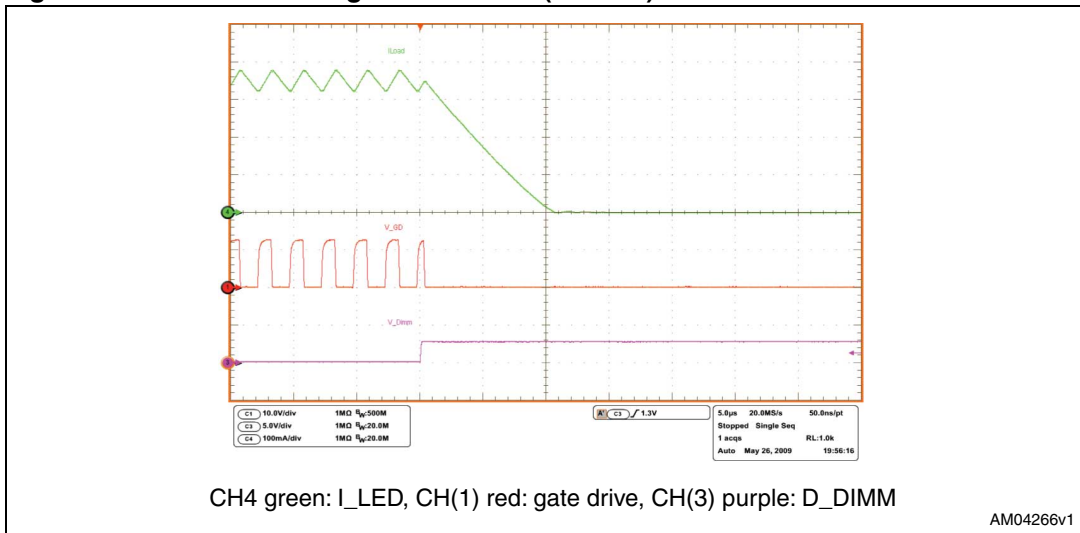

Figure 16. Dimming 1%

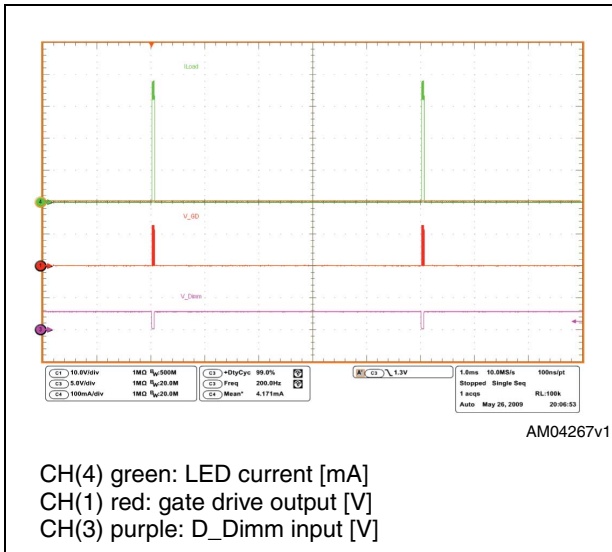

Figure 17. Dimming 10%

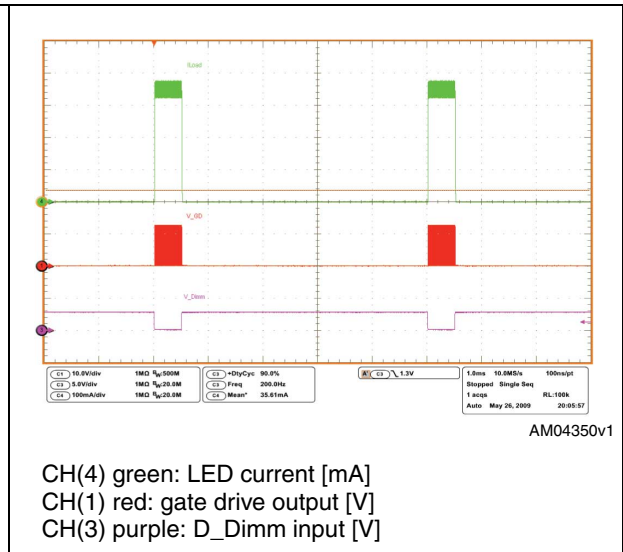

Figure 18. Dimming 50%

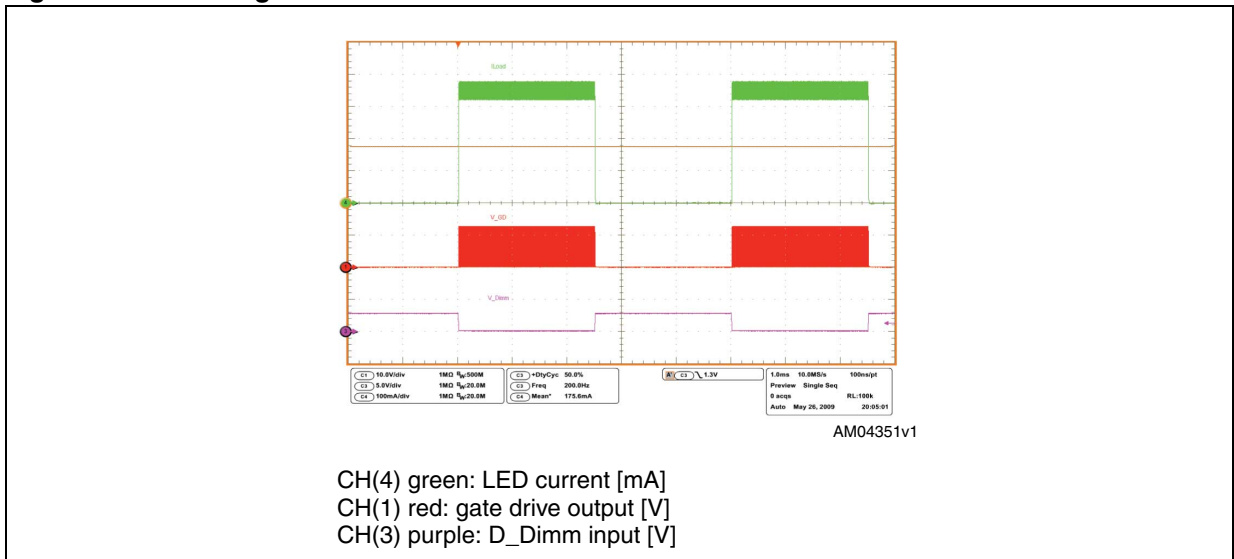

Figure 19. Dimming 90%

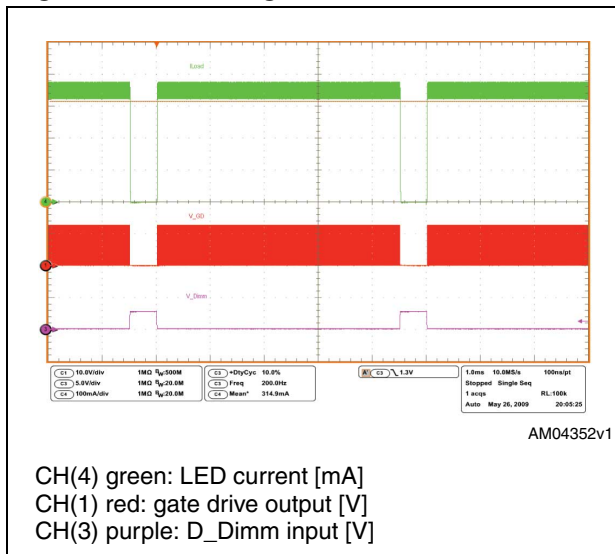
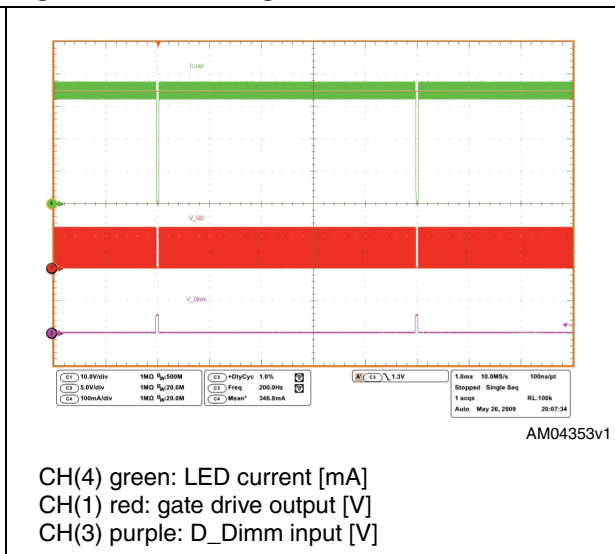

Figure 20. Dimming 99%



2.7 Auxiliary power

The components for the auxiliary power supply are Q1, D2, C2, R2, R3, and R5.

This section is included as a commodity to reduce the main voltage (48 V nominal) to the 18 V required from the Vcc input of the L6562A controller, thus avoiding the use of another power supply. It has been designed to work with input voltages in the range of 33 to 65 V, but can be easily resized for different ranges.

Note that it is a linear regulator and that its efficiency is not very good. For this reason, in real applications where multiple modules are employed, it is better to consider a solution with an external supply common to all the modules.

Simply removing R2 and R5 disconnects the entire block and allows the power supply (Vcc) to be provided from pin 5 of the header connector.

Figure 21. Auxiliary power

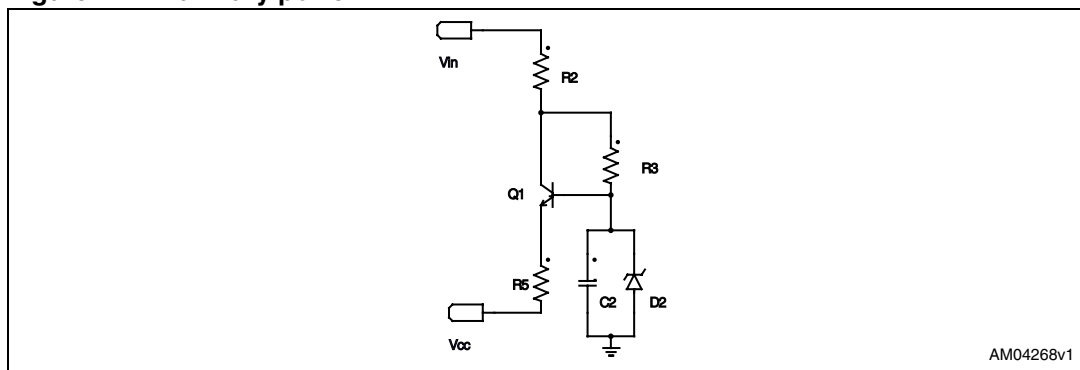

2.8 Open-/short-circuit protection

As indicated, one of the requirements is that the module can sustain open and short circuits indefinitely and restart the correct functionality as soon as the fault is removed.

From the "open circuit" point of view the module is intrinsically safe: if the load is disconnected, no current runs through the sense resistor and the controller drives the power MOSFET transistor in conduction and pin 10 of the J1 connector to ground. Whenever the load is reconnected, the current restarts to flow and normal operation is resumed.

The short-circuit condition is more critical. At the end of the *toff* delay, the power MOSFET is turned on, the current starts to flow and charges the inductor, and the voltage on the sense resistor quickly reaches the threshold level. However, because of the controller's internal delay (175 nS nom.) the power MOSFET does not shut down immediately; as such, a minimal amount of energy is still transferred to the inductor, but during the *toff* time – since the load is a short-circuit – this energy is NOT dissipated.

The result is that the load current rises abnormally, leading to catastrophic failure unless the cycle is blocked.

For this reason the circuit outlined in [Figure 22](#) has been introduced.

Figure 22. Short-circuit protection

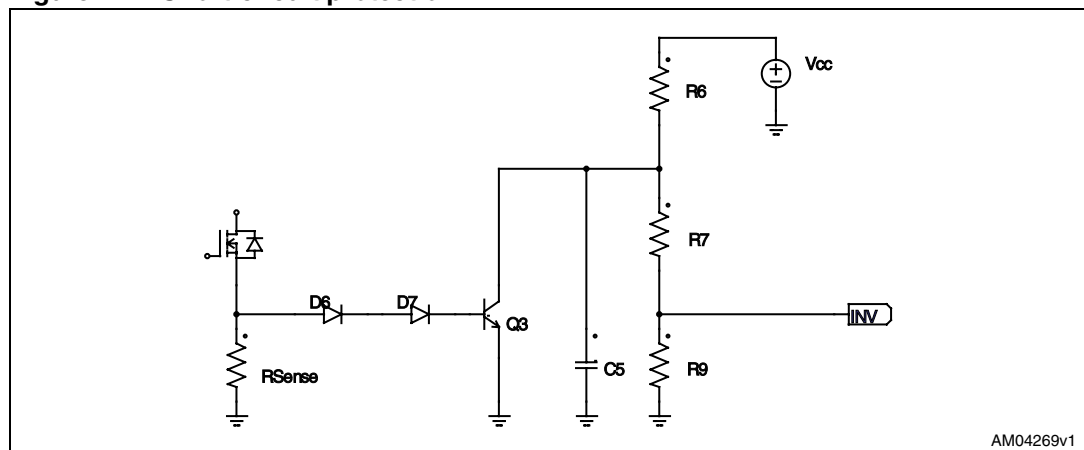

In normal conditions the voltage developed across the sense resistor is not sufficient to turn on Q3. The INV pin of the controller is then at:

Equation 50

$$(V_{cc}) * \left(\frac{R9}{R6 + R7 + R9} \right) = (18V) * \left(\frac{22K}{(220K + 33K + 22K)} \right) = 1.44V$$

On the other hand, in the case of a short-circuit, the load current increases until Q3 goes in conduction, C5 is discharged and the INV pin goes to:

Equation 51

$$(Q3_V_{ce_sat}) * \left(\frac{R9}{R7 + R9} \right) = (0.25V) * \left(\frac{22K}{(33K + 22K)} \right) = (0.25) * (0.4)V = 0.1V$$

The controller then shuts down, the power MOSFET stops conducting, the inductor discharges and the load current decays to zero. Since no current flows through the sense

resistor, Q3 turns off allowing C5 to charge through R6, and the voltage of the INV pin rises again. When it reaches 0.45 V the disable condition is removed and the controller restarts.

If the short-circuit condition is removed, the circuit restores its normal functionality. If the short-circuit condition persists, the hiccup cycle is repeated.

Figure 23. Short-circuit application

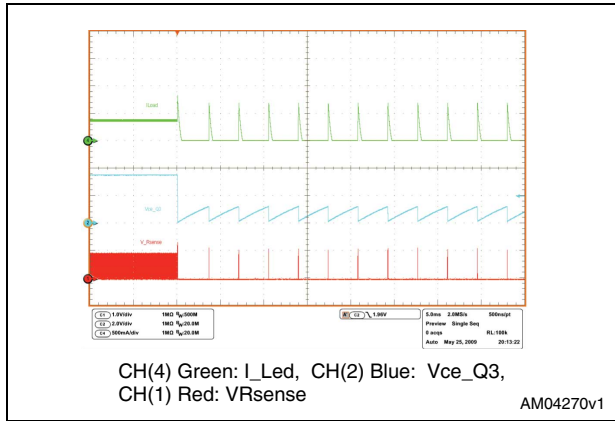

Figure 24. Short-circuit removal

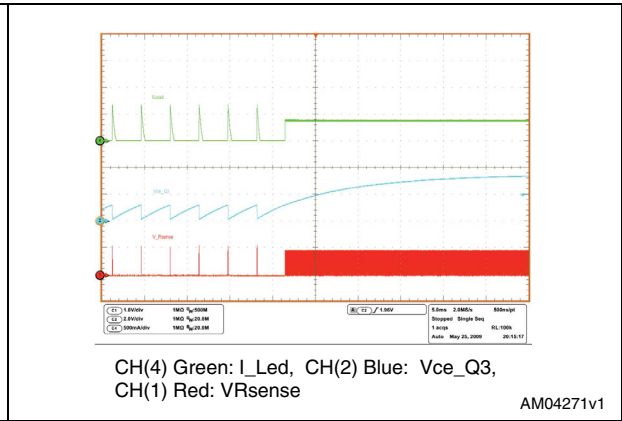

Figure 25. Short-circuit detection

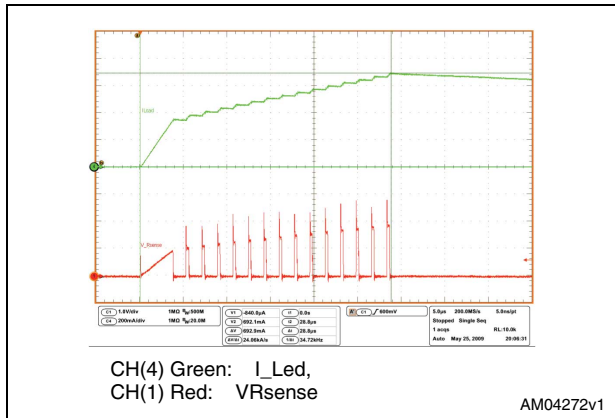
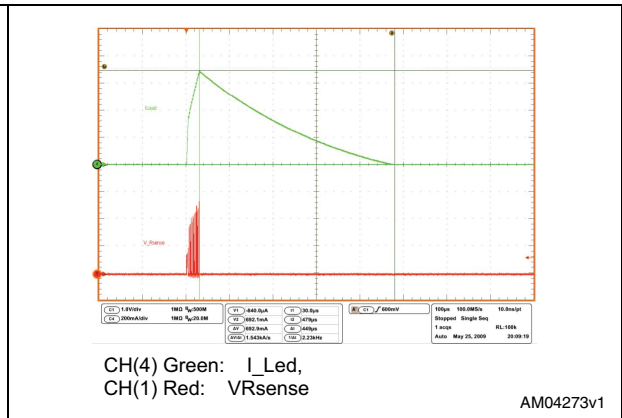

Figure 26. Load current decay



3 Measurements

3.1 LED voltage dependency

The first set of measures was taken at a nominal input voltage with $V_{in} = 48\text{ V}$ and with the output voltage (V_{led}) as a parameter.

Figure 27. LED current (average, maximum, minimum)

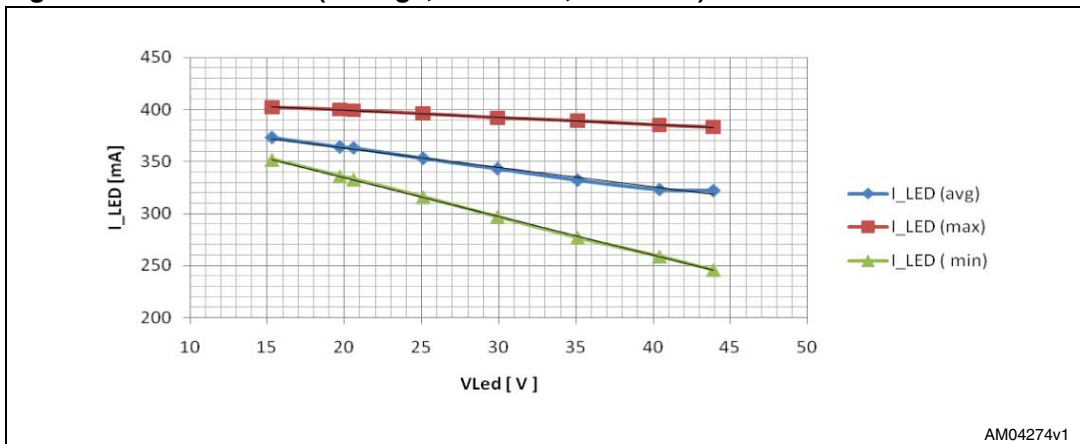

Figure 28. LED current (ripple)

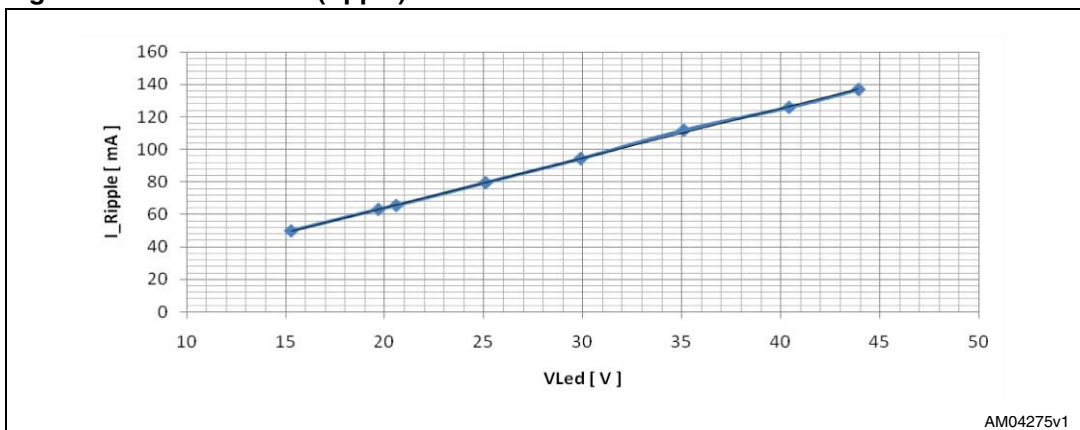

Figure 29. Switching frequency

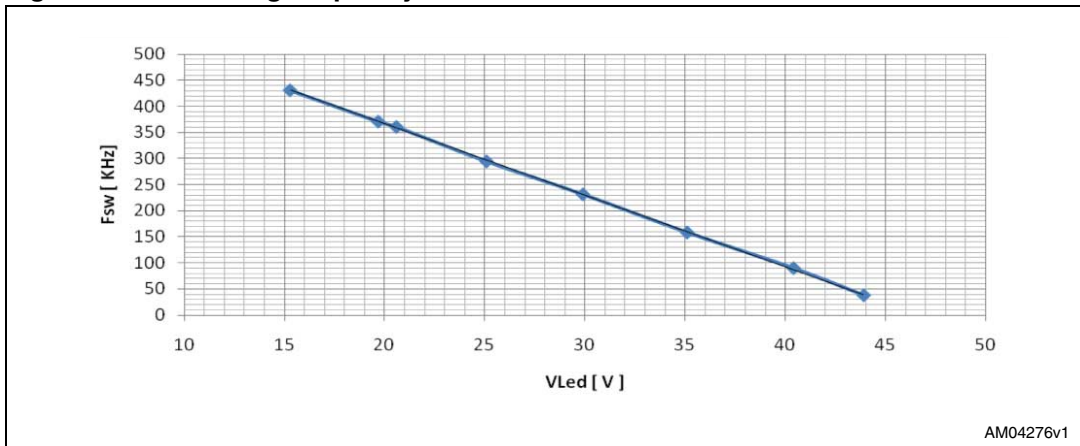

Figure 30. Efficiency [%]

