



Chipsmall Limited consists of a professional team with an average of over 10 year of expertise in the distribution of electronic components. Based in Hongkong, we have already established firm and mutual-benefit business relationships with customers from,Europe,America and south Asia,supplying obsolete and hard-to-find components to meet their specific needs.

With the principle of “Quality Parts,Customers Priority,Honest Operation,and Considerate Service”,our business mainly focus on the distribution of electronic components. Line cards we deal with include Microchip,ALPS,ROHM,Xilinx,Pulse,ON,Everlight and Freescale. Main products comprise IC,Modules,Potentiometer,IC Socket,Relay,Connector.Our parts cover such applications as commercial,industrial, and automotives areas.

We are looking forward to setting up business relationship with you and hope to provide you with the best service and solution. Let us make a better world for our industry!



Contact us

Tel: +86-755-8981 8866 Fax: +86-755-8427 6832

Email & Skype: info@chipsmall.com Web: www.chipsmall.com

Address: A1208, Overseas Decoration Building, #122 Zhenhua RD., Futian, Shenzhen, China





**Amplified HumPRO™ Series
Evaluation Module
Data Guide**

Wireless made simple®

Warning: Some customers may want Linx radio frequency (“RF”) products to control machinery or devices remotely, including machinery or devices that can cause death, bodily injuries, and/or property damage if improperly or inadvertently triggered, particularly in industrial settings or other applications implicating life-safety concerns (“Life and Property Safety Situations”).

NO OEM LINX REMOTE CONTROL OR FUNCTION MODULE SHOULD EVER BE USED IN LIFE AND PROPERTY SAFETY SITUATIONS. No OEM Linx Remote Control or Function Module should be modified for Life and Property Safety Situations. Such modification cannot provide sufficient safety and will void the product’s regulatory certification and warranty.

Customers may use our (non-Function) Modules, Antenna and Connectors as part of other systems in Life Safety Situations, but only with necessary and industry appropriate redundancies and in compliance with applicable safety standards, including without limitation, ANSI and NFPA standards. It is solely the responsibility of any Linx customer who uses one or more of these products to incorporate appropriate redundancies and safety standards for the Life and Property Safety Situation application.

Do not use this or any Linx product to trigger an action directly from the data line or RSSI lines without a protocol or encoder/decoder to validate the data. Without validation, any signal from another unrelated transmitter in the environment received by the module could inadvertently trigger the action.

All RF products are susceptible to RF interference that can prevent communication. RF products without frequency agility or hopping implemented are more subject to interference. This module does have a frequency hopping protocol built in, but the developer should still be aware of the risk of interference.

Do not use any Linx product over the limits in this data guide. Excessive voltage or extended operation at the maximum voltage could cause product failure. Exceeding the reflow temperature profile could cause product failure which is not immediately evident.

Do not make any physical or electrical modifications to any Linx product. This will void the warranty and regulatory and UL certifications and may cause product failure which is not immediately evident.

Table of Contents

- 1 [Description](#)
- 2 [Ordering Information](#)
- 2 [Absolute Maximum Ratings](#)
- 3 [Electrical Specifications](#)
- 4 [Typical Performance Graphs](#)
- 8 [Pin Assignments](#)
- 8 [Pin Descriptions](#)
- 10 [Module Dimensions](#)
- 11 [Module Description](#)
- 14 [Schematic](#)
- 15 [Pad Layout](#)
- 15 [Power Supply Requirements](#)

Amplified HumPRO™ Series Evaluation Module

Data Guide



Figure 1: Amplified HumPRO™ Series Evaluation Module

Description

The Amplified HumPRO™ Series is a frequency hopping spread spectrum (FHSS) transceiver designed for the reliable transfer of digital data. It has a very fast lock time so that it can quickly wake up, send data and go back to sleep. A high-power 25dBm amplifier gives the module exceptional range.

The Amplified HumPRO™ Series module has several features that make the data transfer reliable. A Carrier Sense Multiple Access (CSMA) routine ensures that the channel is clear before the module begins transmitting data. Automatic acknowledgements ensure that the remote side got valid data. Multiple hopping patterns enable multiple systems to operate in proximity without interference. A standard UART interface is used for module configuration and data transfer.

All modules have a unique 32-bit serial number that can be used as an address. Source and destination addressing support point-to-point and broadcast links. Address masking by the receiving module allows for creating subnets. More advanced networks can also be implemented.

The amplified evaluation module contains the surface mount Amplified HumPRO™ Series transceiver module on a board with through-hole headers. The amplified module offers much greater range than the standard module by itself.

Ordering Information

Ordering Information	
Part Number	Description
EVM-A-900-PRO-CAS	Amplified HumPRO™ Series Carrier Board, Castellated Connection with an edge-mount RP-SMA connector
EVM-A-900-PRO-UFL	Amplified HumPRO™ Series Carrier Board, U.FL Connector
HUM-A-900-PRO-CAS	Amplified HumPRO™ Series High Power Data Transceiver with Castellated Connection
HUM-A-900-PRO-UFL	Amplified HumPRO™ Series High Power Data Transceiver with U.FL Connector
MDEV-A-900-PRO	Amplified HumPRO™ Series Master Development System
MDEV-PGDOCK	Development System Programming Dock
MDEV-PROTO	Development System Prototype Board
CON-SOC-EVM	EVM Module Socket Kit

Figure 2: Ordering Information

Absolute Maximum Ratings

Absolute Maximum Ratings				
Supply Voltage V_{CC}	-0.3	to	+3.9	VDC
Any Input or Output Pin	-0.3	to	$V_{CC} + 0.3$	VDC
RF Input		+5		dBm
Operating Temperature	-40	to	+85	°C
Storage Temperature	-40	to	+85	°C

Exceeding any of the limits of this section may lead to permanent damage to the device. Furthermore, extended operation at these maximum ratings may reduce the life of this device.

Figure 3: Absolute Maximum Ratings



Warning: This product incorporates numerous static-sensitive components. Always wear an ESD wrist strap and observe proper ESD handling procedures when working with this device. Failure to observe this precaution may result in module damage or failure.

Electrical Specifications

Amplified HumPRO™ Series Transceiver Specifications						
Parameter	Symbol	Min.	Typ.	Max.	Units	Notes
Power Supply						
Operating Voltage	V_{CC}	2.7	3.3	3.6	VDC	
TX Supply Current	I_{CCTX}					
at +25dBm			380		mA	
at +22dBm			260		mA	1,2
RX Supply Current	I_{CCRX}		39		mA	1,2,3
Power-Down Current	I_{PDN}		<1		μA	1,2
RF Section						
Operating Frequency Band	F_C	902		928	MHz	
Receiver Sensitivity						
@ 19.2kbps RF rate			-108		dBm	5
@ 153.6kbps RF rate			-101		dBm	5
Max Output Power						
@ 19.2kbps RF rate	P_O		+25		dBm	6
@ 153.6kbps RF rate	P_O		+22		dBm	6
Antenna Port						
RF Impedance	R_{IN}		50		Ω	4
Environmental						
Operating Temp. Range		-40		+85	°C	4
1.	Measured at 3.3V V_{CC}					4. Characterized but not tested
2.	Measured at 25°C					5. PER = 1%
3.	Input power -60dBm					6. Into a 50-ohm load

Figure 4: Electrical Specifications

Please see the Amplified HumPRO™ Series Transceiver module data guide for full electrical specifications.

Pin Assignments

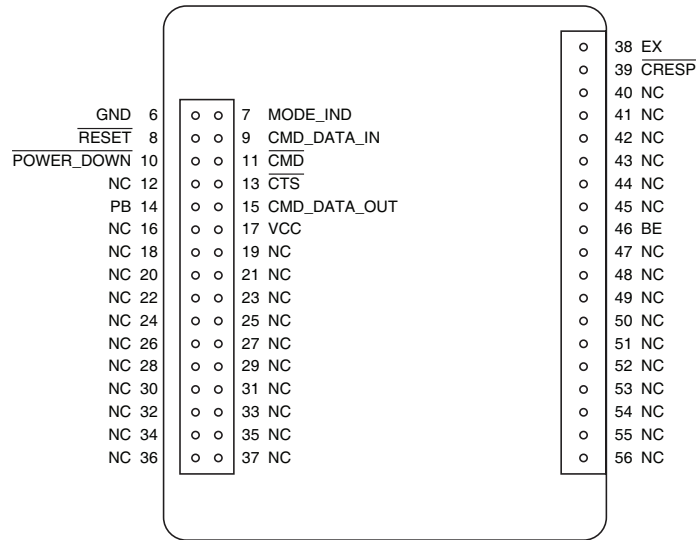

Figure 5: EVM-A-fff-PRO Pin Assignments

Pin Descriptions

Pin Descriptions			
Pin Number	Name	I/O	Description
6	GND	—	Ground
7	MODE_IND	O	Mode Indicator. This line indicates module activity. It can source enough current to drive a small LED, causing it to flash. The duration of the flashes indicates the module's current state.
8	RESET	I	This line resets the module when pulled low. It should be high for normal operation. This line has an internal 10k resistor to supply, so leave it unconnected if not used.
9	CMD_DATA_IN	I	Command Data In. Input line for data (CMD is high) and serial commands (CMD is low).
10	POWER_DOWN	I	Power Down. Pulling this line low places the module into a low-power state. The module is not functional in this state. Pull high for normal operation. Do not leave floating.
11	CMD	I	Command Input. When this line is low, incoming bytes are command data. When high, incoming bytes are data to be transmitted.

Pin Descriptions			
Pin Number	Name	I/O	Description
12, 18, 19, 21-37, 40-56	NC	—	No Electrical Connection. Do not connect any traces to these lines.
13	CTS	O	UART Clear To Send, active low. This line indicates to the host microcontroller when the module is ready to accept data. When CTS is high, the module is busy. When CTS is low, the module is ready for data.
14	PB	I	Push Button input. This line can be connected to Vcc through a normally open push button. Button sequences can reset configurations to default and join modules into a network. Pull low when not in use; do not leave floating.
15	CMD_DATA_OUT	O	Command Data Out. Output line for data and serial commands
17	VCC	—	Supply Voltage
38	EX	O	Exception Output. A mask can be set to take this line high when an exception occurs. The line is lowered when the exception register is read (EXCEPT).
39	CRESP	O	Command Response. This line is low when the data on the CMD_DATA_OUT line is a response to a command and not data received over the air.
46	BE	O	Buffer Empty. This line is high when the UART input buffer is empty, indicating that all data has been transmitted. If acknowledgment is active, it also indicates that the receiving module has acknowledged the data or a retry exception has occurred.

Figure 6: EVM-A-fff-PRO Pin Descriptions

Schematic

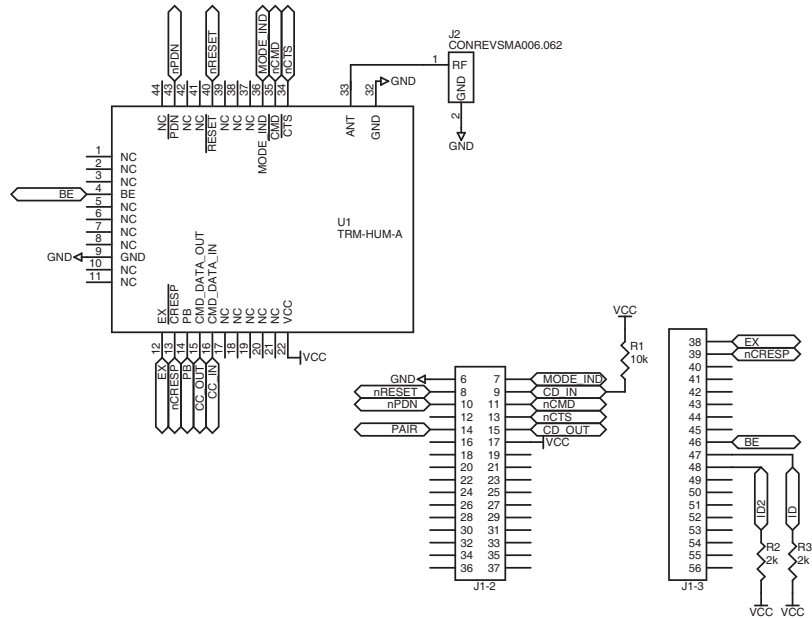

Figure 7: EVM-A-fff-PRO Schematic

Module Dimensions

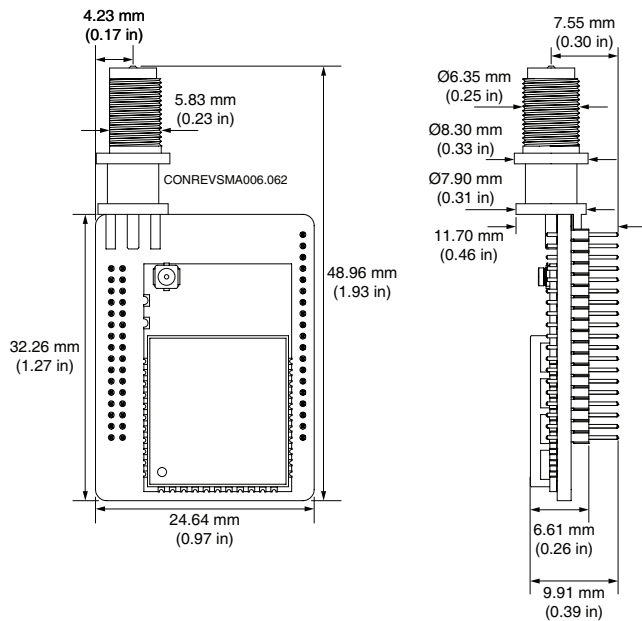

Figure 8: EVM-A-fff-PRO Dimensions

Pad Layout

Figure 9 shows the recommended PCB layout for the evaluation module.

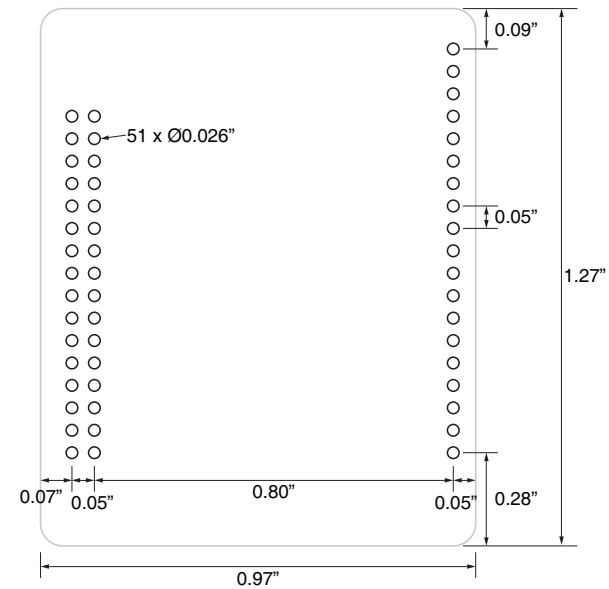

Figure 9: EVM-A-fff-PRO PCB Layout Dimensions

Power Supply Requirements

The transceiver incorporates a precision low-dropout regulator which allows operation over a wide input voltage range. Despite this regulator, it is still important to provide a supply that is free of noise. Power supply noise can significantly affect the module's performance, so providing a clean power supply for the module should be a high priority during design.

Consider the module's max supply current of 380mA when designing the power delivery network. Thin traces for the supply and ground connections may not be able to supply enough current and may degrade the module's performance.



Linx Technologies
159 Ort Lane
Merlin, OR, US 97532

Phone: +1 541 471 6256
Fax: +1 541 471 6251

www.linxtechnologies.com

Disclaimer

Linx Technologies is continually striving to improve the quality and function of its products. For this reason, we reserve the right to make changes to our products without notice. The information contained in this Data Guide is believed to be accurate as of the time of publication. Specifications are based on representative lot samples. Values may vary from lot-to-lot and are not guaranteed. "Typical" parameters can and do vary over lots and application. Linx Technologies makes no guarantee, warranty, or representation regarding the suitability of any product for use in any specific application. It is the customer's responsibility to verify the suitability of the part for the intended application. **NO LINX PRODUCT IS INTENDED FOR USE IN ANY APPLICATION WHERE THE SAFETY OF LIFE OR PROPERTY IS AT RISK.**

Linx Technologies **DISCLAIMS ALL WARRANTIES OF MERCHANTABILITY AND FITNESS FOR A PARTICULAR PURPOSE. IN NO EVENT SHALL LINX TECHNOLOGIES BE LIABLE FOR ANY OF CUSTOMER'S INCIDENTAL OR CONSEQUENTIAL DAMAGES ARISING IN ANY WAY FROM ANY DEFECTIVE OR NON-CONFORMING PRODUCTS OR FOR ANY OTHER BREACH OF CONTRACT BY LINX TECHNOLOGIES.** The limitations on Linx Technologies' liability are applicable to any and all claims or theories of recovery asserted by Customer, including, without limitation, breach of contract, breach of warranty, strict liability, or negligence. Customer assumes all liability (including, without limitation, liability for injury to person or property, economic loss, or business interruption) for all claims, including claims from third parties, arising from the use of the Products. The Customer will indemnify, defend, protect, and hold harmless Linx Technologies and its officers, employees, subsidiaries, affiliates, distributors, and representatives from and against all claims, damages, actions, suits, proceedings, demands, assessments, adjustments, costs, and expenses incurred by Linx Technologies as a result of or arising from any Products sold by Linx Technologies to Customer. Under no conditions will Linx Technologies be responsible for losses arising from the use or failure of the device in any application, other than the repair, replacement, or refund limited to the original product purchase price. Devices described in this publication may contain proprietary, patented, or copyrighted techniques, components, or materials. Under no circumstances shall any user be conveyed any license or right to the use or ownership of such items.

©2017 Linx Technologies. All rights reserved.

The stylized Linx logo, Wireless Made Simple, WISE, CipherLinx and the stylized CL logo are trademarks of Linx Technologies.