



Chipsmall Limited consists of a professional team with an average of over 10 year of expertise in the distribution of electronic components. Based in Hongkong, we have already established firm and mutual-benefit business relationships with customers from,Europe,America and south Asia,supplying obsolete and hard-to-find components to meet their specific needs.

With the principle of “Quality Parts,Customers Priority,Honest Operation,and Considerate Service”,our business mainly focus on the distribution of electronic components. Line cards we deal with include Microchip,ALPS,ROHM,Xilinx,Pulse,ON,Everlight and Freescale. Main products comprise IC,Modules,Potentiometer,IC Socket,Relay,Connector.Our parts cover such applications as commercial,industrial, and automotives areas.

We are looking forward to setting up business relationship with you and hope to provide you with the best service and solution. Let us make a better world for our industry!



Contact us

Tel: +86-755-8981 8866 Fax: +86-755-8427 6832

Email & Skype: info@chipsmall.com Web: www.chipsmall.com

Address: A1208, Overseas Decoration Building, #122 Zhenhua RD., Futian, Shenzhen, China



7mm Square Encoders

Type: **EVQVU**



■ Features

- Smaller and lower product height type (Product height H=7mm)
- Good rotation feel
- Supports vertical self-standing mounting onto printed circuit boards

■ Recommended Applications

- Information & communications equipment
- For input devices of measuring instruments and various electronic equipment
- Portable electronic equipment

■ Explanation of Part Numbers

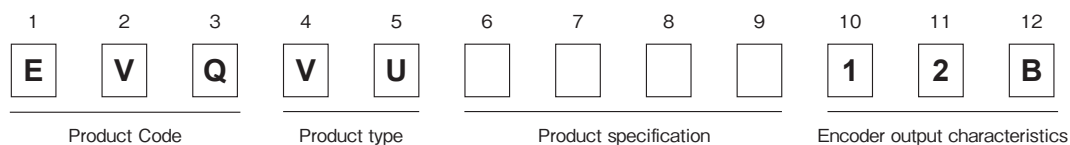

■ Specifications

Mechanical	Rotation angle	360° (Endless)
	Rotation Torque	5mN·m
	Detents	24 points
Electrical	Output signals	Phase A and B
	Resolution	12 pulses/360°
	Rating	1mA 10V DC (at each bit)
	Contact resistance	10Ω max.
	Insulation resistance	50MΩ min. (at 50V DC)
	Dielectric Withstanding Voltage	50V AC for 1 minute
	Bouncing	15ms max. (at rotational speed 30 r/min.)
Endurance	Rotation life	100,000 cycles min.
Minimum Quantity/Packing Unit		500 pcs. (Tray Pack)
Quantity/Carton		5,000 pcs.

Design and specifications are each subject to change without notice. Ask factory for the current technical specifications before purchase and/or use.
Should a safety concern arise regarding this product, please be sure to contact us immediately.

■ Dimensions in mm (not to scale)

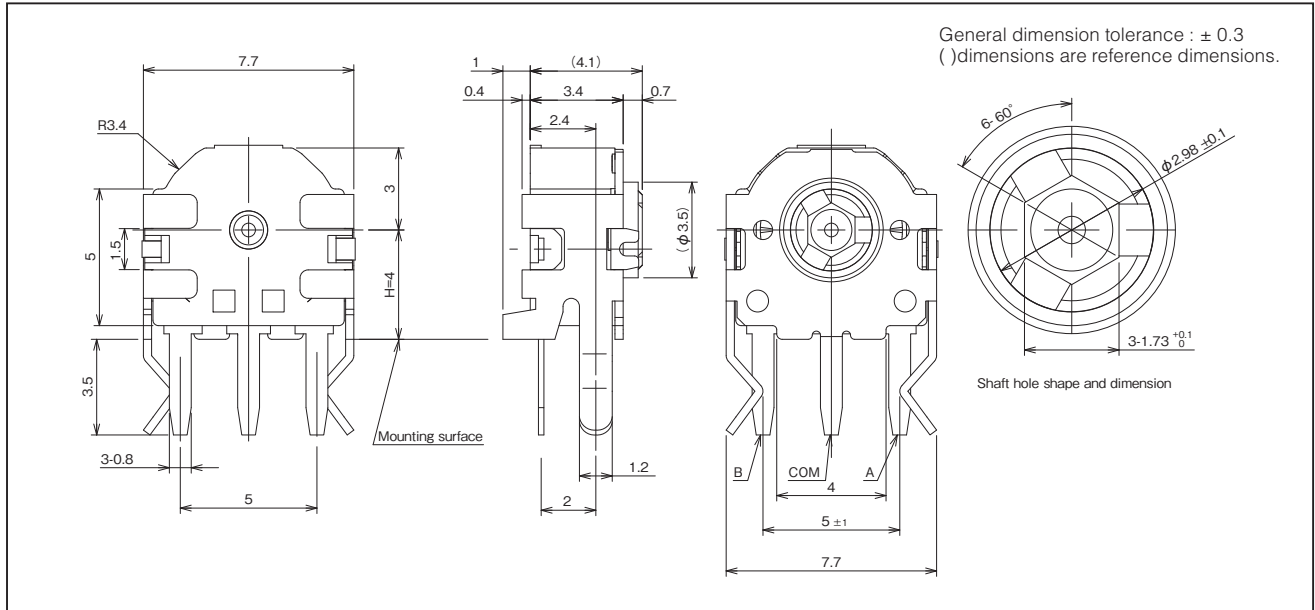

■ PWB mounting hole for reference

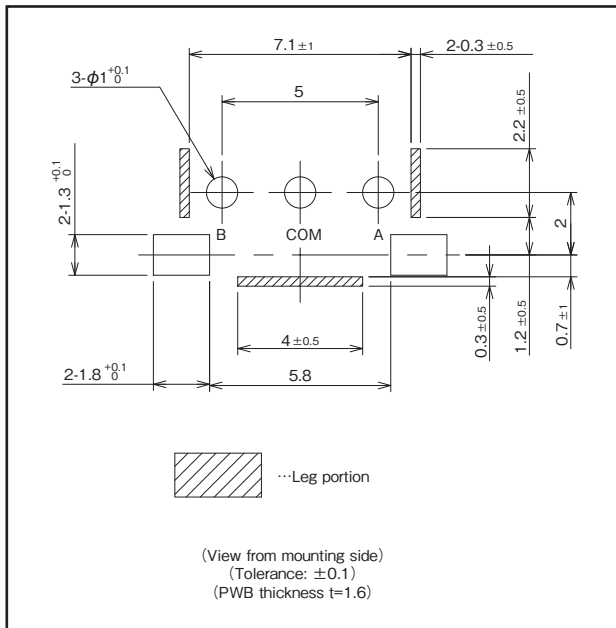

■ Circuit Diagram

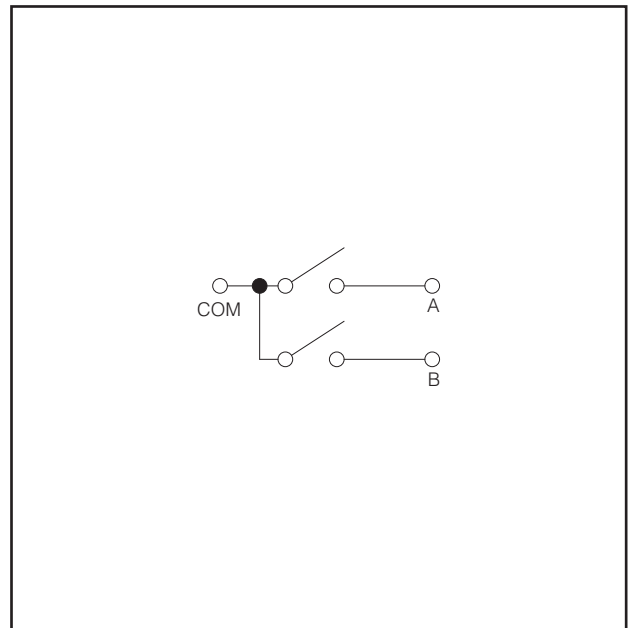

■ Phase Difference

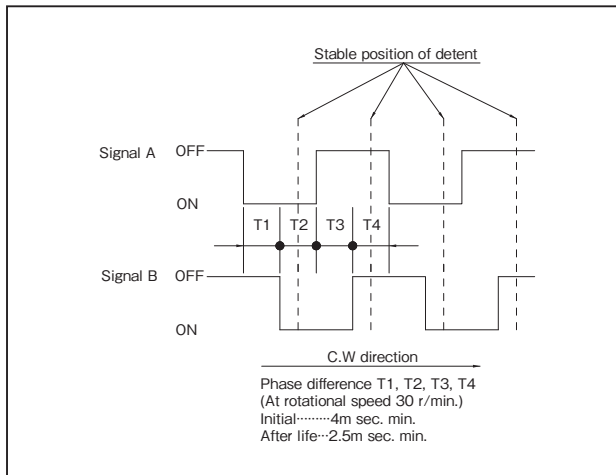

■ Test Circuit Diagram

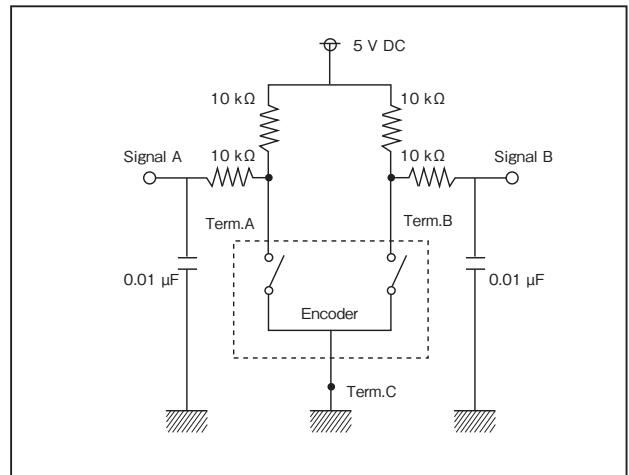

Design and specifications are each subject to change without notice. Ask factory for the current technical specifications before purchase and/or use.
 Should a safety concern arise regarding this product, please be sure to contact us immediately.