



Chipsmall Limited consists of a professional team with an average of over 10 year of expertise in the distribution of electronic components. Based in Hongkong, we have already established firm and mutual-benefit business relationships with customers from,Europe,America and south Asia,supplying obsolete and hard-to-find components to meet their specific needs.

With the principle of “Quality Parts,Customers Priority,Honest Operation,and Considerate Service”,our business mainly focus on the distribution of electronic components. Line cards we deal with include Microchip,ALPS,ROHM,Xilinx,Pulse,ON,Everlight and Freescale. Main products comprise IC,Modules,Potentiometer,IC Socket,Relay,Connector.Our parts cover such applications as commercial,industrial, and automotives areas.

We are looking forward to setting up business relationship with you and hope to provide you with the best service and solution. Let us make a better world for our industry!



Contact us

Tel: +86-755-8981 8866 Fax: +86-755-8427 6832

Email & Skype: info@chipsmall.com Web: www.chipsmall.com

Address: A1208, Overseas Decoration Building, #122 Zhenhua RD., Futian, Shenzhen, China



Bluetooth[®] Module

EYSMACAXX Series (RF+Baseband (Class 2))

Data Report

Part Number (EYSMACAXX) is modified for mass production.
Please ask for the detail from the local sales office.

In case you adopt this module and design some appliance, please
ask for the latest specifications from the local sales office.

We wish the customer to request the Specification Report when the
design for the mass production begins because the content of this
Data Report might change without a previous notice to the customer.

The *Bluetooth*[®] word mark and logos are owned by the *Bluetooth* SIG, Inc. and any use of such marks by TAIYO YUDEN CO., LTD. is under license.

EYSMACAXX SeriesTAIYO YUDEN Confidential
& Tentative**Document constituent list**

Control name	Control No.	Document Page
General Items	HD-AG-A080180	1/3 - 3/3
Absolute maximum ratings	HD-AM-A080180	1/1
Electrical characteristics	HD-AE-A080180	1/6 - 6/6
Electrical characteristics	HD-AE-B080180	1/2 - 2/2
Electrical characteristics	HD-AE-C080180	1/11 - 11/11
Electrical characteristics	HD-AE-D080180	1/11 - 11/11
Block Diagram	HD-MC-A080180	1/1
Outline / Appearance	HD-AD-A080180	1/1
Outline / Appearance	HD-AD-B080180	1/1
Pin Layout	HD-BA-A080180	1/2 - 2/2
Reflow Profile	-	1/1

Rev. record

9-Dec.-2008> Ver.0.1 Draft

15-Jan.-2009> Ver.0.2

30-Jan.-2009> Ver.0.3

16-Jun.-2009> Ver.0.4

2-Mar.-2010> Ver.1.0

15-Feb.-2013> Ver.1.1

EYSMACAXX SeriesTAIYO YUDEN Confidential
& Tentative

Control No. HD-AG-A080180	(1/3)	Control name General Items
------------------------------	-------	-------------------------------

Scope

This specification (“Specification”) applies to the hybrid IC “EYSMACA” for use **Bluetooth**[®] module (“Product”) manufacture by TAIYO YUDEN Co., Ltd. (“TAIYO YUDEN”)

1. Part Number: EYSMACAXX (UART/PCM I/F Support)

- Digit3: Customer Code ex) S: TAIYO YUDEN Standard
- Digit8: Hardware Code ex) X: TAIYO YUDEN Standard
- Digit9: Software Code ex) X: TAIYO YUDEN Standard

*** Part Number may be modified for mass production or other cases.**

Please see “m” for more information.

2. Function: Radio frequency transfer Module (power class 2). **Bluetooth**[®] standard Ver 2.1+EDR conformity

3. Application: Laptop PC, PC peripheral, Handy terminal

4. Structure: Hybrid IC loaded with silicon monolithic semiconductor

5. Outline: 39 pin leadless chip carrier

6. Marking: BD address, Lot and TAIYO YUDEN on shielding case.

7. Features:

- Bluetooth**[®] 2.1+EDR conformity
- Interface: UART/PCM
- Encryption
- Hold, Sniff and Park Mode
- Supported Link Type: ACL links (Piconet<7>), (e)SCO links (Piconet<3>)
- AFH
- EDR (Enhanced Data Rate)

8. Packing: Tray

Packaging method: Tray & aluminum moisture barrier bag

Packaging unit: 2860 pieces/tray

9. Terminal: 39 pin leadless chip carrier

10. Mount: SMD Type

11. Notes:

- a. Any question arising from this Specification shall be solved through mutual discussion by the parties hereof.
- b. This Product is not designed for radiation durable and should not be used under the circumstance of radiation.
- c. The operating conditions of this Product are as shown in this Specification. Please note that TAIYO YUDEN shall not be liable for a failure and/or abnormality which is caused by use under the conditions other than the operating conditions hereof.
- d. This Product mentioned in this Specification is manufactured for use in Laptop PC. Before using this Product in any special equipment (such as medical equipment, space equipment, air craft, disaster prevention equipment), where higher safety and reliability are duly required, the applicability and suitability of this Product must be fully evaluated by the customer at its sole risk to ensure correct and safety operation of those special equipments. Also, evaluation of the safety function of this Product even for use in general electronics equipment shall be thoroughly made and when necessary, a protective circuit shall be added in design stage, all at the customer’s sole risk.
- e. TAIYO YUDEN warrants only that this Product is in conformity with this Specification for one year after purchase and shall in no event give any other warranty.

EYSMACAXX SeriesTAIYO YUDEN Confidential
& Tentative

Control No. HD-AG-A080180	(2/3)	Control name General Items
------------------------------	-------	-------------------------------

- f. The warranty period shall be one year.
- g. Communication between this Product and others might not be established nor maintained depending upon radio environment or operating conditions of this Product and other **Bluetooth**[®] products.
- h. This Product is designed for use in products which comply with **Bluetooth**[®] Specifications (Ver 2.1+EDR) (“Bluetooth Specifications”). TAIYO YUDEN disclaims and is not responsible for any liability concerning infringement by this Product under any intellectual property right owned by third party in case the customer uses this Product in any product which does not comply with Bluetooth Specifications (the “non-complying products”). Furthermore, TAIYO YUDEN warrants only that this Product complies with this Specification and does not grant any other warranty including warranty for application of the non-complying products.
- i. TAIYO YUDEN does not render updating or upgrading service for the firmware in the Module.
- j. In order to take tests for getting the certification of each country’s Radio Law with a device incorporating this module, it is necessary to make the software in Host to put the module into test condition. Please contact TAIYO YUDEN for farther details.
- k. Please evaluate adequately our module incorporated to your products before mass production.
- l. This Product operates in the unlicensed ISM band at 2.4GHz. In case this Product is used around the other wireless devices which operate in same frequency band of this Product, there is a possibility that interference occurs between this Product and such other devices. If such interference occurs, please stop the operation of other devices or relocate this Product before using this Product or do not use this Product around the other wireless devices.
- m. Part Number Modification Notice (**Bluetooth**[®] Modules)
Part numbers for sample modules or part numbers you see in this Specification are TAIYO YUDEN standard part numbers. In case of modification made to any modules, to meet requested specifics, the part number will carry a different part number, due to forfeit originality. Additionally, part numbers may be modified based on mass production stage, **Bluetooth**[®] logo Qualification stage, or other related stages. Please see the following examples for cases that User’s Code are modified:
- for specific firmware version (our standard item firmware will be upgraded occasionally)
 - for specific BD address (our standard item BD address is owned by TAIYO YUDEN)
 - for different baud rate (our standard is 115.2kbps and partly 1Mbps)
 - for specific PnP (Plug and Play) IDs (our standard item PnP IDs are owned by TAIYO YUDEN or chip manufacture)
 - for other related cases (specific or different setting, form, sizes, or display etc..)
- In case you have applied for **Bluetooth**[®] Qualification with our standard User’s Code without previous notice to TAIYO YUDEN, we shall not be responsible for any expense that will be required to change its name/number.
- n. Containment of hazardous substance in this Product
- *Pb (Lead) : Non use
- * This product conforms to RoHS Directive(2002/95/EC).
- p. In addition when this Product is used under environmental conditions such as over voltage which are not guaranteed, it may be destroyed in short mode. To ensure the security of customer’s product, please add an extra fuse or/and a protection circuit for over voltage.
- q. In some cases, TAIYO YUDEN may use replacements as component parts of Products. Such replacement shall apply only to component part of Products, which TAIYO YUDEN deems it possible to replace or substitute according to (i) Scope provided in this Specification (e.g. Official Standard (Type Approvals, Bluetooth LOGO etc.)) and (ii) Quality of Products. TAIYO YUDEN also ensures traceability of such replacement on production lot basis.

EYSMACAXX SeriesTAIYO YUDEN Confidential
& Tentative

Control No. HD-AG-A080180	(3/3)	Control name General Items
------------------------------	-------	-------------------------------

r. Do not alter Hardware and/or Software of this Product.

Please note that TAIYO YUDEN shall not be liable for any problem if it is caused by customer's alteration of Hardware or/and Software without Taiyo Yuden's prior approvals.

This module is still under development, thus specifications do not guarantee both the quality and reliability at the time of shipment. Since the specifications and mass production of the module are not confirmed either, the contents of the technical notes are subject to change without any prior notice.

EYSMACAXX SeriesTAIYO YUDEN Confidential
& Tentative

Control No. HD-AM-A080180	(1/1)	Control name Absolute maximum ratings
------------------------------	-------	--

Absolute maximum ratings

Item	Symbol	Rating				Remark
		Min.	Typ.	Max.	Unit	
Supply voltage	VDD_PIO, VDD_USB	-0.4		3.7	V	Ta=25 degrees C, GND reference
	VREG_IN	-0.4		5.6	V	
Input voltage	Vin	-0.3		VDD+0.3	V	I/O terminals except USB interface

Recommendation operating range

Item	Symbol	Rating				Remark
		Min.	Typ.	Max.	Unit	
Supply voltage	VDD_PIO	1.7	3.3	3.6	V	
	VDD_USB	1.7	3.3	3.6	V	
	VREG_IN	2.2	-	4.2	V	
Supply voltage ripple and spike noise	VDD_rn			30	mVp-p	Note 1
Operation temperature range	Topr	-20	25	75	Degrees C	Humidity=40%RH Note 2
Storage temperature range	Tstg	-30	25	85	Degrees C	Humidity=40%RH Note 3

Notes:

- To fill the standard of "Supply voltage ripple and spike noise", the capacitor, which has the capacity of 2.2uF or more, should be put in the terminal VDD outside as a bypass capacitor.
- Operating temperature range is set to satisfy products electrical characteristics in the short term.
In terms of product life cycle when it is used in condition of varying from TYP standard in the long term, please refer to the reliability condition.
- Storage temperature range is the condition for transportation and storage in temporary.

EYSMACAXX SeriesTAIYO YUDEN Confidential
& Tentative

Control No. HD-AE-A080180	(1/6)	Control name Electrical characteristics
------------------------------	-------	--

Electrical characteristic**DC Specifications**

The Specification applies for Topr.= 25 degrees C, VDD_PIO=VDD_USB=VREG_IN=3.3V

No.	Parameter	Condition	Symbol	Min.	Typ.	Max.	Unit	Remark
1	Normal supply voltage 1		VDD_PIO	1.7	3.3	3.6	V	
2	Normal supply voltage 2		VDD_USB	1.7	3.3	3.6	V	
3	Normal supply voltage 3		VREG_IN	2.2	-	4.2	V	
4	Input Low Voltage 1	/RESET, PIOX, PCM_IN, PCM_SYNC, PCM_CLK, UART_CTS, UART_RX	VIL1	0		0.8	V	
5	Input Low Voltage 2	USB_DP, USB_DN	VIL2	-		0.8	V	
6	Input High Voltage 1	/RESET, PIOX, PCM_IN, PCM_SYNC, PCM_CLK, UART_CTS, UART_RX	VIH1	0.7xVDD		VDD+0.3	V	
7	Input High Voltage 2	USB_DP, USB_DN	VIH2	2.0		-	V	
8	Output Low Voltage 1	PIOX, PCM_OUT, PCM_SYNC, PCM_CLK, UART_TX, UART_RTS	VOL1	-		0.4	V	IOL=4mA
9	Output Low Voltage 2	USB_DP, USB_DN	VOL2	-		0.3	V	
10	Output High voltage 1	PIOX, PCM_OUT, PCM_SYNC, PCM_CLK, UART_TX, UART_RTS	VOH1	VDD-0.4		-	V	IOH=-4mA
11	Output High voltage 2	USB_DP, USB_DN	VOH2	2.8		-	V	
12	Peak current	Continuous Rx	Icp1		40	120	mA	Notes 3, 4
13	Average current1	Sniff mode (Slave only)	Icca1		6	-	mA	Notes 1, 3, 4
14	Average current2	Standby mode	Icca2		2	-	mA	Notes 3, 4
15	Average current3	Send DM1packet (Master)	Icca3		36	-	mA	Notes 3, 4
16	Average current4	Receive DM1packet (Slave)	Icca4		35	-	mA	Notes 3, 4
17	Average current5	Hold mode (Slave only)	Icca5		2	-	mA	Notes 3, 4
18	Average current6	Park mode (Slave only)	Icca6		3	-	mA	Notes 2, 3, 4

Notes:

- Sniff mode parameter.
 - Max interval 0050h
 - Min interval 0010h
 - Attempt 0005h
 - Timeout 0005h
- Park mode parameter.
 - Max interval 0100h
 - Min interval 0010h
- The consumption current might fluctuate with the condition of radio communication, host performance and test circuit.
- The value may fluctuate several (mA) depending on Firmware version.

EYSMACAXX SeriesTAIYO YUDEN Confidential
& Tentative

Control No. HD-AE-A080180	(2/6)	Control name Electrical characteristics
------------------------------	-------	--

AC Specifications (UART)

The Specification applies for Topr.= 25 degrees C, VDD_PIO=VDD_USB=VREG_IN=3.3V

No.	Parameter	Condition	Symbol	Min	Typ	Max	Unit	Remark
1	VDD_PIO, VDD_USB Rise Time from 0V to 3.0V		t1	0		2	ms	
2	VREG_IN Rise Time from 0V to 3.0V		t2	0		2	ms	
3	VDD_PIO, VDD_USB high to VREG_IN high		t3	0		2	ms	
4	VREG_IN high to VDD_PIO, VDD_USB high		t4	0		2	ms	
5	VREG_IN high to /RESET high		t5	10			ms	Notes 1, 2
6	VDD_PIO, VDD_USB high to /RESET high		t6	10			ms	Notes 1, 2
7	/RESET high to Module Ready		t7		(1000)	3000	ms	Notes 3, 4, 5
8	/RESET pulse width		t8	6			ms	
9	/RESET low to VDD_PIO, VDD_USB low		t9	0		2	ms	
10	VDD_PIO, VDD_USB low to VREG_IN low		t10	0		2	ms	
11	/RESET low to VRE_IN low		t11	0		2	ms	
12	VREG_IN low to VDD_PIO, VDD_USB low		t12	0		2	ms	

Notes:

- This module has an internal flash memory and a function to erase/sort unnecessary data if certain HCI commands are issued and consume more than a certain level of free space in the EEPROM. This operation occurs at every module initialization (power-on).
If supply voltage becomes non-defined states during initialization or writing in EEPROM, data in EEPROM might be destroyed. If the data in EEPROM is destroyed, module will not work correctly. Therefore please be sure to stabilize power source before /RESET release.
In addition please design module peripheral circuits to avoid temporary blackout of power source during operation. Please refer HD-AE-C080180 for HCI command which rewrites flash memory data.
- Input /RESET signal of 10ms and more in condition of VDD at over 3.0V.
- When the module is ready to accept the command, its module outputs the "04 0F 04 00 01 00 00" (Hex) to the UART TX Data Line. After that, please access to the module.
- The Typ. is a reference value. The value may change depending on the firmware version, conditions of use and types of flash memory.
- It may change due to the firmware version.

EYSMACAXX Series

TAIYO YUDEN Confidential
& Tentative

Control No. HD-AE-A080180	(3/6)	Control name Electrical characteristics
------------------------------	-------	--

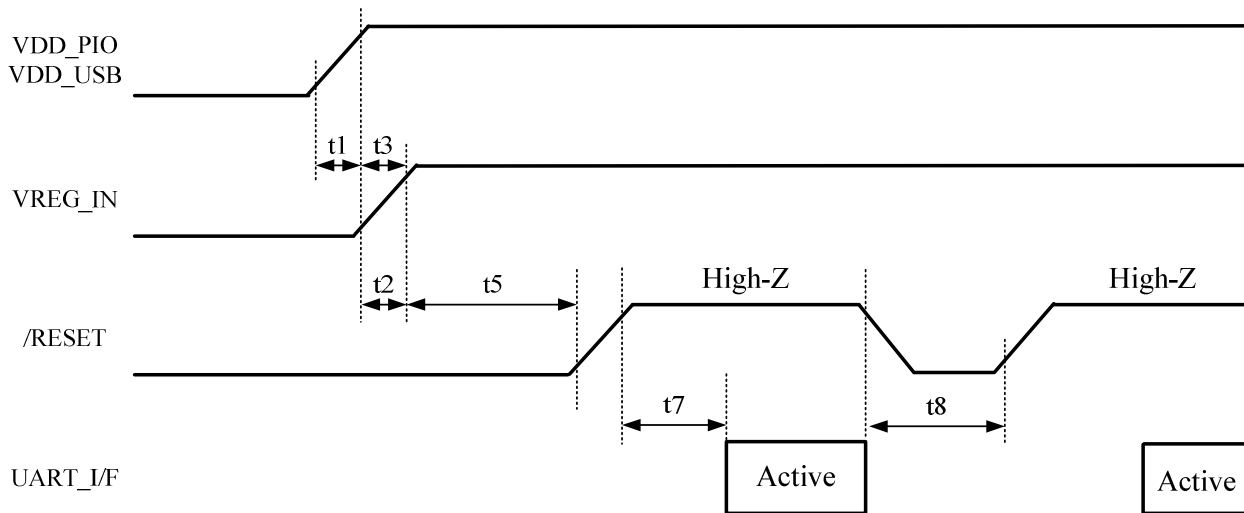

Timing Diagram for Power Up Sequence 1

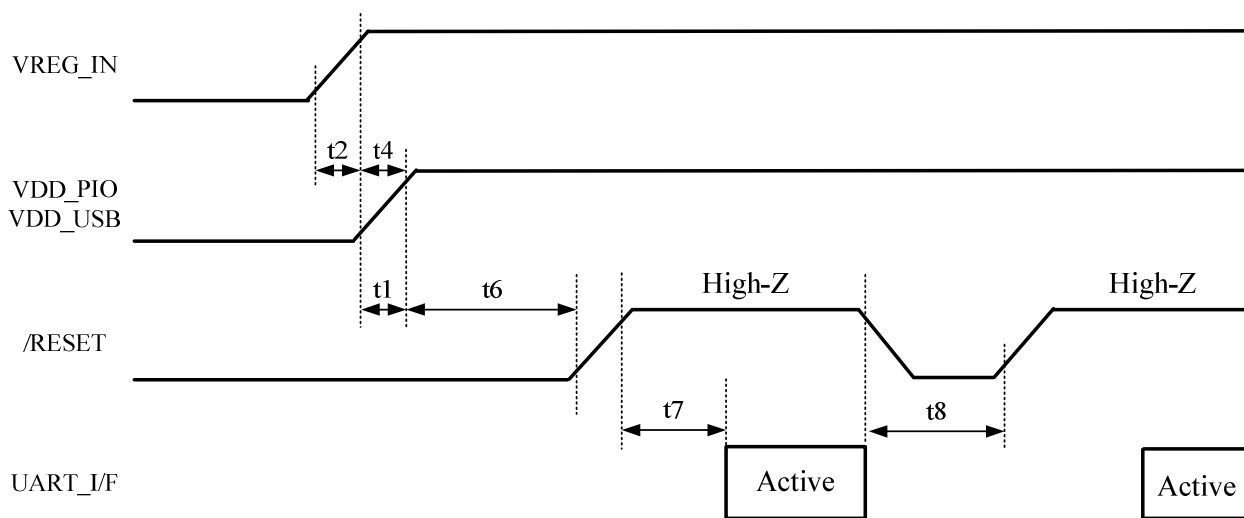

Timing Diagram for Power Up Sequence 2

EYSMACAXX Series

TAIYO YUDEN Confidential
& Tentative

Control No. HD-AE-A080180	(4/6)	Control name Electrical characteristics
------------------------------	-------	--

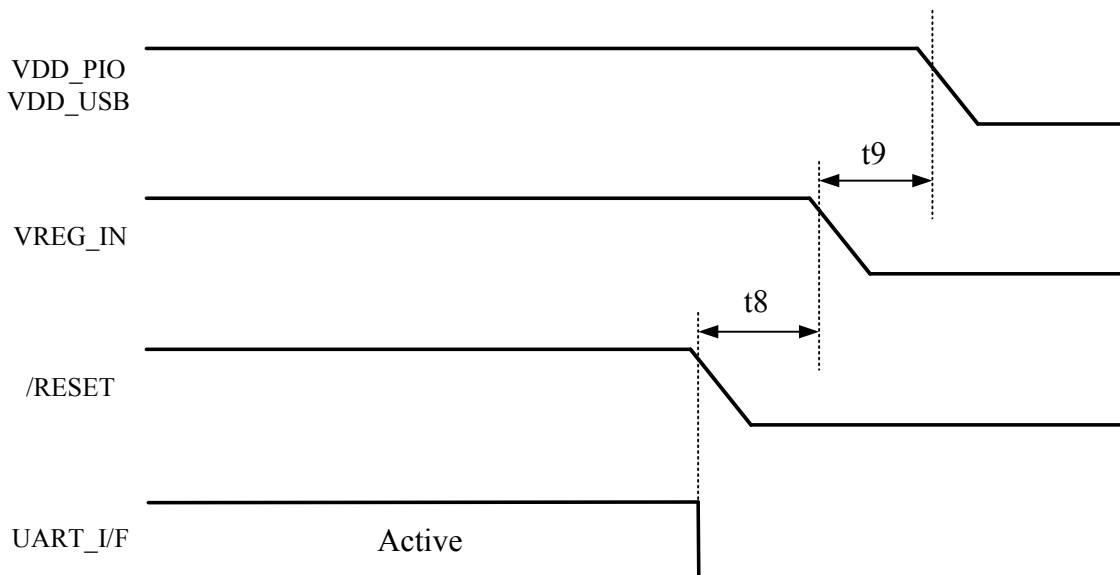

Timing Diagram for Power Down Sequence 1

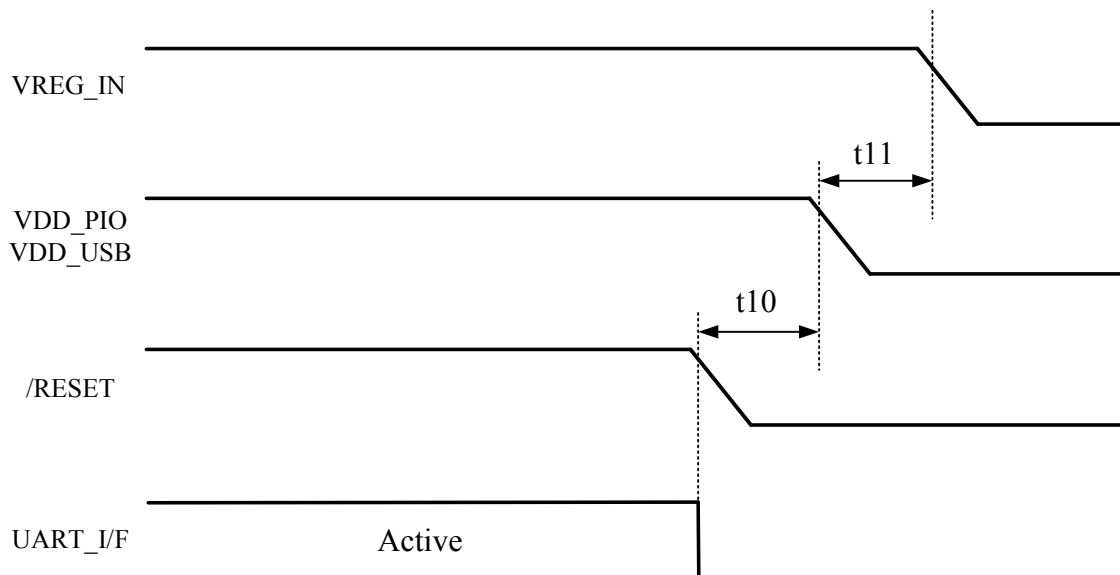

Timing Diagram for Power Down Sequence 2

EYSMACAXX Series

TAIYO YUDEN Confidential
& Tentative

Control No. HD-AE-A080180	(5/6)	Control name Electrical characteristics
------------------------------	-------	--

AC Specifications

UART Interface

The Specification applies for Topr.= 25 degrees C, VDD_PIO=VDD_USB=VREG_IN=3.3V

No.	Parameter	Condition	Symbol	Min	Typ	Max	Unit	Remark
1	RTS Low to RX Data On		t1	0			ms	
2	RTS High to RX Data Off		t2			1	byte	
3	CTS Low to TX Data On		t3	0			ms	
4	CTS High to TX Data Off		t4			2	byte	
5	CTS High Pulse Width		t5	4			bit	

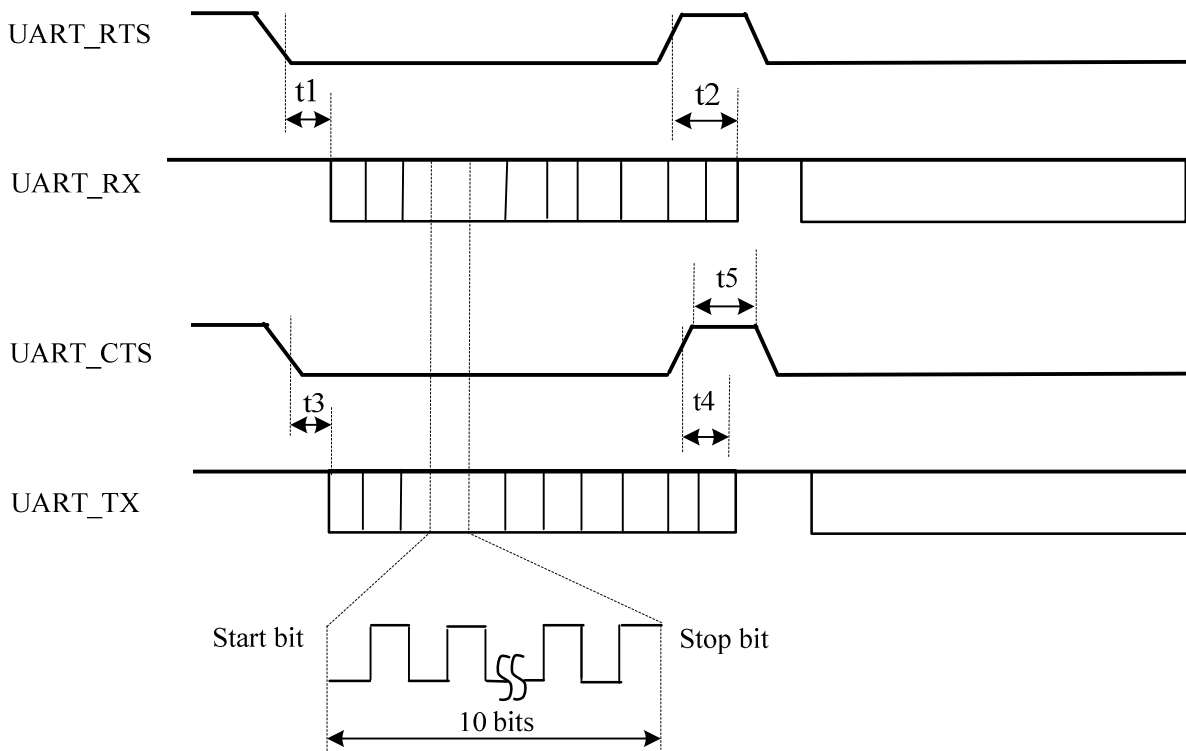

Timing Diagram for UART signals

<UART Parameters>

Item	Parameter
Baud Rate	115.2kbps, see Note
Date Bits	8bits
Stop Bits	1bit
Parity	None
Flow Control	CTS/RTS

EYSMACAXX Series

TAIYO YUDEN Confidential
& Tentative

Control No. HD-AE-A080180	(6/6)	Control name Electrical characteristics
------------------------------	-------	--

PCM Interface

Support CODEC: MC145483 (MOTOROLA)

Please contact TAIYO YUDEN if you want to use the other CODEC.

AC Specifications

The Specification applies for Topr.= 25 degrees C, VDD_PIO=VDD_USB=VREG_IN=3.3V

No.	Parameter	Condition	Symbol	Min	Typ	Max	Unit	Remark
1	PCM_CLK Frequency		t1	-	256	-	kHz	
2	PCM_SYNC Frequency		t2	-	8	-	kHz	
3	PCM_CLK High		t3	980			ns	
4	PCM_CLK Low		t4	730			ns	
5	Delay time from PCM_CLK High to PCM_SYNC High		t5			20	ns	
6	Delay time from PCM_CLK High to valid PCM_OUT		t6			20	ns	
7	Delay time from PCM_CLK Low to PCM_SYNC Low (Long Frame SYNC only)		t7			20	ns	
8	Delay time from PCM_CLK High to PCM_OUT invalid		t8			20	ns	
9	Setup time for PCMIN valid to PCM_CLK Low		t9	30			ns	
10	Hold time for PCM_CLK Low to PCM_IN valid		t10	10			ns	

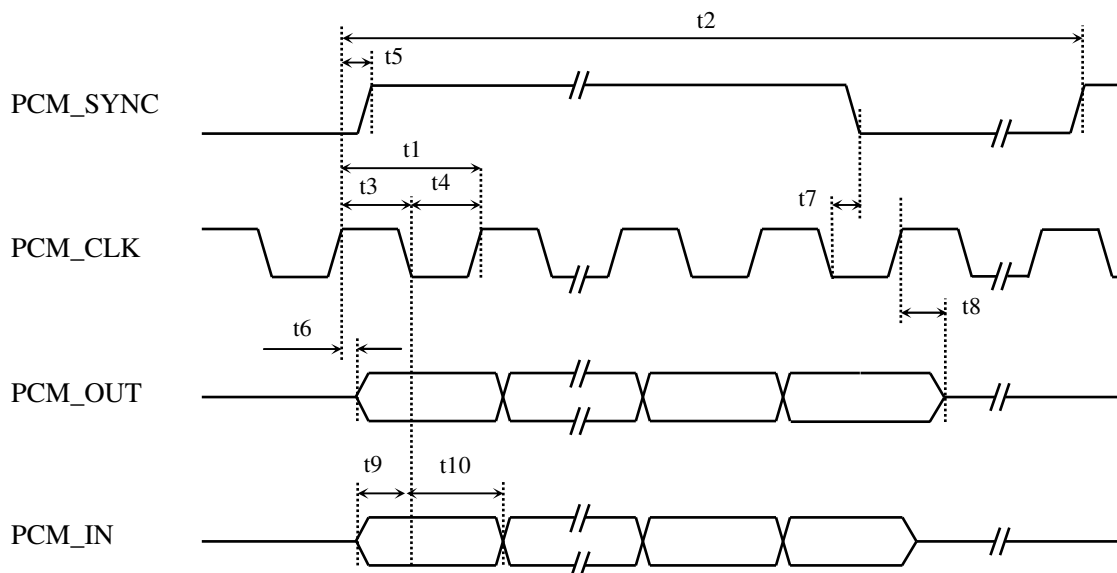

SPI Interface

This module does not support SPI Interface.

EYSMACAXX SeriesTAIYO YUDEN Confidential
& Tentative

Control No. HD-AE-B080180	(1/2)	Control name Electrical characteristics
------------------------------	-------	--

RF Specifications at Basic Rate

The Specification applies for Ta=25 degrees C, VDD_PIO=VDD_USB=VREG_IN=3.3V

No.	Parameter	Condition	Symbol	Min	Typ	Max	Unit	Remark
1	Frequency band		FREQ	2400		2483.5	MHz	
2	Tx power		PO	-6	0	+4	dBm	
3	Modulation characteristics 1	dF1: F0(11110000)	M1	140		175	kHz	
4	Modulation characteristics 2	dF2: AA(10101010)	M4	115			kHz	
5	Modulation characteristics 3	dF2/dF1	MC	0.8				
6	In-band spurious emission 2	2MHz(M-N =2)	ISE1			-20	dBm	
7	In-band spurious emission 3	3MHz or greater (M-N >=3)	ISE2			-40	dBm	
8	Initial Carrier Frequency		ICF	-75		+75	kHz	
9	Frequency Drift 1	DH1	FD1	-25		+25	kHz	
10	Frequency Drift 2	DH3,DH5	FD2	-40		+40	kHz	
11	Drift rate	DH1,DH3,DH5	DR			400	Hz/us	
12	C/I co-channel		CIC			11	dB	-60dBm
13	C/I 1MHz		CI1			0	dB	-60dBm
14	C/I 2MHz		CI2			-30	dB	-60dBm
15	C/I >= 3MHz		CI3			-40	dB	-67dBm
16	C/I Image		CI4			-9	dB	-3MHz offset -67dBm
17	C/I Image +/- 1MHz		CI5			-20	dB	-67dBm
18	Out-of-Band Blocking 1	30MHz to 2000MHz f=2460MHz	OBB1			-10	dBm	BER<=0.1%
19	Out-of-Band Blocking 2	2000 to 2399MHz f=2460MHz	OBB2			-27	dBm	BER<=0.1%
20	Out-of-Band Blocking 3	2484 to 3000MHz f=2460MHz	OBB3			-27	dBm	BER<=0.1%
21	Out-of-Band Blocking 4	3000MHz to 12.75GHz f=2460MHz	OBB4			-10	dBm	BER<=0.1%
22	Maximum Input Level		MAXP	-20			dBm	BER<=0.1%
23	20dB Bandwidth		B20			1	MHz	
24	Sensitivity-single	DH1	SEN1			-70	dBm	BER<=0.1%
25	Sensitivity-multi	DH3,DH5	SEN2			-70	dBm	BER<=0.1%

EYSMACAXX SeriesTAIYO YUDEN Confidential
& Tentative

Control No. HD-AE-B080180	(2/2)	Control name Electrical characteristics
------------------------------	-------	--

RF Specifications at EDR

The Specification applies for Ta=25 degrees C, VDD_PIO=VDD_USB=VREG_IN=3.3V

No.	Parameter	Condition	Symbol	Min	Typ	Max	Unit	Remark
1	RMS DEVM 1	Pai/4DQPSK	RDE1			0.20		
2	RMS DEVM 2	8DPSK	RDE2			0.13		
3	Peak DEVM 1	Pai/4DQPSK	PDE1			0.35		
4	Peak DEVM 2	8DPSK	PDE2			0.25		
5	99% DEVM 1	Pai/4DQPSK	D991			0.30		
6	99% DEVM 2	8DPSK	D992			0.20		
7	EDR In-band spurious emission 1	M-N =1	EISE1	26			dB	
8	EDR In-band spurious emission 2	M-N =2	EISE2			-20	dBm	
9	EDR In-band spurious emission 3	M-N =3	EISE3			-40	dBm	
10	EDR Initial Carrier Frequency		EICF	-75		+75	kHz	
11	EDR Drift		ED	-10		+10	kHz	
12	Relative transmit power	PDPSK	RTP	PGFSK -4		PGFSK +1	dB	
13	Actual Sensitivity Level	2-DH5(3-DH5) 16000000bit	ESEN			-70	dBm	BER= 10 ⁻⁴
14	BER Floor Performance	2-DH5(3-DH5) 160000000bit	FSEN			-60	dBm	BER= 10 ⁻⁵
15	C/I co-channel	2-DH5	2CIC			13	dB	-60dBm
16	C/I 1MHz	2-DH5	2CI1			0	dB	-60dBm
17	C/I 2MHz	2-DH5	2CI2			-30	dB	-60dBm
18	C/I >= 3MHz	2-DH5	2CI3			-40	dB	-67dBm
19	C/I Image	2-DH5	2CI4			-7	dB	-67dBm -3MHz offset
20	C/I Image +/- 1MHz	2-DH5	2CI5			-20	dB	-67dBm
21	C/I co-channel	3-DH5	3CIC			21	dB	-60dBm
22	C/I 1MHz	3-DH5	3CI1			5	dB	-60dBm
23	C/I 2MHz	3-DH5	3CI2			-25	dB	-60dBm
24	C/I >= 3MHz	3-DH5	3CI3			-33	dB	-67dBm
25	C/I Image	3-DH5	3CI4			0	dB	-67dBm -3MHz offset
26	C/I Image +/- 1MHz	3-DH5	3CI5			-13	dB	-67dBm
27	Maximum Input Level	2-DH5(3-DH5)	EMAX P	-20			dBm	

Note:

Bluetooth® standard Ver 2.1+EDR conformity

EYSMACAXX SeriesTAIYO YUDEN Confidential
& Tentative

Control No. HD-AE-C080180	(1/11)	Control name Electrical characteristics
------------------------------	--------	--

Supported HCI Commands / HCI Events

The **Bluetooth**® functions of this module is as written in the attached PICS. Depending on firmware version Upgrade, the **Bluetooth**® functions are subject to change without notice.

HCI COMMAND LIST

Firmware Version 23C (Build4839)

Command Description	OpCode	Group (Hex)	Command (Hex)	Parameters	Returns	Status	Notes
---------------------	--------	-------------	---------------	------------	---------	--------	-------

Device Setup

HCI_Reset	0x0C03	3	3		States	Yes	
-----------	--------	---	---	--	--------	-----	--

Controller Flow Control

HCI_Read_Buffer_Size	0x1005	4	5		Status	Yes	
					HC ACL Data Packet Length		
					HC Synchronous Data Packet Length		
					HC Total Num ACL Data Packets		
					HC Total Num Synchronous Data Packets		

Controller Information

HCI_Read_Local_Version_Information	0x1001	4	1		Status	Yes	
					HCI Version		
					HCI Revision		
					LMP Version		
					Manufacturer Name		
HCI_Read_Local_Supported_Commands	0x1002	4	2		Status	Yes	
					Supported Commands		
HCI_Read_Local_Supported_Features	0x1003	4	3		Status	Yes	
					LMP Features		
HCI_Read_Local_Extended_Features	0x1004	4	4	Page number	Status	Yes	
					Page number		
					Maximum Page Number		
					Extended LMP Features		
HCI_Read_BD_ADDR	0x1009	4	9		Status	Yes	
					BD ADDR		

Controller Configuration

HCI_Read_Local_Name	0x0C14	3	14		States	Yes	
HCI_Write_Local_Name	0x0C13	3	13	Local Name	States	Yes	
HCI_Read_Class_of_Device	0x0C23	3	23		States	Yes	
					Class of Device		
HCI_Write_Class_of_Device	0x0C24	3	24	Class of Device	States	Yes	
HCI_Read_Number_Of_Support_IAC	0x0C38	3	38		States	Yes	
					Num Support IAC		
HCI_Read_Current_IAC_LAP	0x0C39	3	39		States	Yes	
					Num Current IAC		
					IAC LAP [I]		
HCI_Write_Current_IAC_LAP	0x0C3A	3	3A	Num Current IAC IAC LAP [I]	States	Yes	
					IAC LAP [I]		
HCI_Read_Scan_Enable	0x0C19	3	19		States	Yes	
					Scan Enable		
HCI_Write_Scan_Enable	0x0C1A	3	1A	Scan Enable	States	Yes	

EYSMACAXX SeriesTAIYO YUDEN Confidential
& Tentative

Control No. HD-AE-C080180	(2/11)	Control name Electrical characteristics
------------------------------	--------	--

Device Discover

HCI_Inquiry	0x0401	1	1	LAP		Yes	
				Inquiry Length			
				Num Responses			
HCI_Inquiry_Cancel	0x0402	1	2		Status	Yes	
HCI_Periodic_Inquiry_Mode	0x0403	1	3	Max Period Length	Status	Yes	
				Min Period Length			
				LAP			
				Inquiry Length			
HCI_Exit_Periodic_Inquiry_Mode	0x0404	1	4		Status	Yes	
HCI_Read_Inquiry_Scan_Activity	0x0C1D	3	1D		States	Yes	
					Inquiry Scan Interval		
					Inquiry Scan Window		
HCI_Write_Inquiry_Scan_Activity	0x0C1E	3	1E	Inquiry Scan Interval	States	Yes	
				Inquiry Scan Window			
HCI_Read_Inquiry_Scan_Type	0x0C42	3	42		Status	Yes	
HCI_Write_Inquiry_Scan_Type	0x0C43	3	43	Scan Type	Status	Yes	
HCI_Read_Inquiry_Mode	0x0C44	3	44		Status	Yes	
HCI_Write_Inquiry_Mode	0x0C45	3	45	Inquiry Mode	Status	Yes	
HCI_Read_Inquiry_Response_Transmit_Power_Level	0x0C58	3	58		Status	Yes	
					TX_Power		
HCI_Write_Inquiry_Transmit_Power_Level	0x0C59	3	59	TX_Power	Status	Yes	
HCI_Read_Extended_Inquiry_Response	0x0C51	3	51		Status	Yes	
					FEC_Required		
					Extended_Inquiry_Response		
HCI_Write_Extended_Inquiry_Response	0x0C52	3	52	FEC_Required	Status	Yes	
				Extended_Inquiry_Response			

Connection Setup

HCI_Create_Connection	0x0405	1	5	BD ADDR		Yes	
				Packet Type			
				Page Scan Repetition Mode			
				Reserved			
				Clock Offset			
				Allow Role Switch			
HCI_Accept_Connection_Request	0x0409	1	9	BD ADDR		Yes	
				Role			
HCI_Reject_Connection_Request	0x040A	1	A	BD ADDR		Yes	
				Reason			
HCI_Create_Connection_Cancel	0x0408	1	8	BD ADDR	Status	Yes	
					BD ADDR		
HCI_Disconnect	0x0406	1	6	Connection Handle		Yes	
				Reason			
				Packet Type			
HCI_Read_Page_Timeout	0x0C17	3	17		States	Yes	
					Page Timeout		
HCI_Write_Page_Timeout	0x0C18	3	18	Page Timeout	States	Yes	
HCI_Read_Page_Scan_Activity	0x0C1B	3	1B		States	Yes	
					Page Scan Interval		
					Page Scan Window		

EYSMACAXX SeriesTAIYO YUDEN Confidential
& Tentative

Control No. HD-AE-C080180	(3/11)	Control name Electrical characteristics
------------------------------	--------	--

HCI_Write_Page_Scan_Activity	0x0C1C	3	1C	Page Scan Interval Page Scan Window	States	Yes	
HCI_Read_Page_Scan_Type	0x0C46	3	46		States	Yes	
HCI_Write_Page_Scan_Type	0x0C47	3	47	Page_Scan_Type	Page_Scan_Type	Yes	
HCI_Read_Connection_Accept_Timeout	0x0C15	3	15		Status Conn_Accept_Timeout	Yes	
HCI_Write_Connection_Accept_Timeout	0x0C16	3	16	Conn_Accept_Timeout	Status	Yes	

Remote Information

HCI_Remote_Name_Request	0x0419	1	19	BD_ADDR Page Scan Repetition Mode Page Scan Mode Clock Offset		Yes	
HCI_Remote_Name_Request_Cancel	0x041A	1	1A	BD_ADDR	Status BD_ADDR	Yes	
HCI_Read_Remote_Supported_Features	0x041B	1	1B	Connection Handle		Yes	
HCI_Read_Remote_Extended_Features	0x041C	1	1C	Connection Handle Page_Number		Yes	
HCI_Read_Remote_Version_Information	0x041D	1	1D	Connection Handle		Yes	

Synchronous Connections

HCI_Setup_Synchronous_Connection	0x0428	1	28	Connection Handle Transmit Bandwidth Receive Bandwidth Max Latency Voice Setting Retransmission Effort Packet Type		Yes	
HCI_Accept_Synchronous_Connection_Request	0x0429	1	29	BD_ADDR Transmit Bandwidth Receive Bandwidth Max Latency Content Format Retransmission Effort Packet Type		Yes	
HCI_Reject_Synchronous_Connection_Request	0x042A	1	2A	BD_ADDR		Yes	
HCI_Read_Voice_Setting	0x0C25	3	25		States Voice Setting	Yes	
HCI_Write_Voice_Setting	0x0C26	3	26	Voice setting	States	Yes	
HCI_Write_Default_Erroneous_Data_Reporting	0x0C5B	3	5B	Erroneous_Data_Reporting	Status	No	
HCI_Read_Default_Erroneous_Data_Reporting	0x0C5A	3	5A		Status Erroneous_Data_Reporting	No	

EYSMACAXX SeriesTAIYO YUDEN Confidential
& Tentative

Control No. HD-AE-C080180	(4/11)	Control name Electrical characteristics
------------------------------	--------	--

Connection State

HCI_Hold_Mode	0x0801	2	1	Connection Handle		Yes	
				Hold Mode Max Interval			
				Hold Mode Min Interval			
HCI_Sniff_Mode	0x0803	2	3	Connection Handle		Yes	
				Sniff Max Interval			
				Sniff Min Interval			
				Sniff Attempt			
HCI_Sniff_Mode	0x0803	2	3	Sniff Timeout			
HCI_Exit_Sniff_Mode	0x0804	2	4	Connection Handle		Yes	
HCI_Park_State	0x0805	2	5	Connection Handle		Yes	
				Beacon Max Interval			
				Beacon Min Interval			
HCI_Exit_Park_State	0x0806	2	6	Connection Handle		Yes	
HCI_Read_Link_Policy_Settings	0x080C	2	C	Connection Handle	States	Yes	
					Connection Handle		
					Link Policy Settings		
HCI_Write_Link_Policy_Settings	0x080D	2	D	Connection Handle	States	Yes	
				Link Policy settings	Connection Handle		
HCI_Read_Default_Link_Policy_Settings	0x080E	2	E		Status	Yes	
					Default Link Policy Settings		
HCI_Write_Default_Link_Policy_Settings	0x080F	2	F	Default Link Policy Settings	Status	Yes	
HCI_Read_Hold_Mode_Activity	0x0C2B	3	2B		States	Yes	
					Hold Mode Activity		
HCI_Write_Hold_Mode_Activity	0x0C2C	3	2C	Hold Mode Activity	States	Yes	

Piconet Structure

HCI_Role_Discovery	0x0809	2	9	Connection Handle	Status	Yes	
					Connection Handle		
					Current Role		
HCI_Switch_Role	0x080B	2	B	BD ADDR		Yes	
				Role			

Quality Service

HCI_Flow_Specification	0x0810	2	10	Connection Handle		Yes	
				Flags			
				Flow direction			
				Service Type			
				Token Rate			
				Token Bucket Size			
				Peak Bandwidth			
Access Latency							
HCI_QoS_Setup	0x0807	2	7	Connection Handle		Yes	
				Flags			
				Service Type			
				Token Rate			
				Peak Bandwidth			
				Latency			
Delay Variation							
HCI_Flush	0x0C08	3	8	Connection Handle	States	Yes	
					Connection Handle		
HCI_Read_Automatic_Flush_Timeout	0x0C27	3	27	Connection Handle	States	Yes	
					Connection Handle		
					Flush Timeout		

EYSMACAXX SeriesTAIYO YUDEN Confidential
& Tentative

Control No. HD-AE-C080180	(5/11)	Control name Electrical characteristics
------------------------------	--------	--

HCI_Write_Automatic_Flush_Timeout	0x0C28	3	28	Connection Handle	States	Yes		
				Flash Timeout	Connection Handle			
HCI_Read_Failed_Contact_Counter	0x1401	5	1	Connection Handle	Status	Yes		
					Connection Handle			Failed Contact Counter
					Failed Contact Counter			
HCI_Reset_Failed_Contact_Counter	0x1402	5	2	Connection Handle	Status	Yes		
					Connection Handle			
HCI_Read_Num_Broadcast_Retransmission	0x0C29	3	29		States	Yes		
HCI_Write_Num_Broadcast_Retransmission	0x0C2A	3	2A	Num Broadcast Retransmission	States	Yes		
HCI_Enhanced_Flush	0x0C5F	3	5F	Connection_Handle		Yes		
				Packet_Type				
				Connection_Handle				
				Maximum_Latency				
				Minimum_Remote_Timeout				
Minimum_Local_Timeout								

Physical Links

HCI_Read_Link_Supervision_Timeout	0x0C36	3	36	Connection Handle	States	Yes		
					Connection Handle			Link Supervision Timeout
					Link Supervision Timeout			
HCI_Write_Link_Supervision_Timeout	0x0C37	3	37	Connection Handle	States	Yes		
				Link Supervision Timeout	Connection Handle			
HCI_Read_AFH_Channel_Assessment_Mode	0x0C48	3	48		Status	Yes		
					AFH Channel Assessment Mode			
HCI_Write_AFH_Channel_Assessment_Mode	0x0C49	3	49	AFH Channel Assessment Mode	Status	Yes		
HCI_Set_AFH_Host_Channel_Classification	0x0C3F	3	3F	AH Host Channel Classification	Status	Yes		
HCI_Change_Connection_Packet_Type	0x040F	1	F	Connection Handle		Yes		
				Packet Type				

Host Flow Control

HCI_Host_Buffer_Size	0x0C33	3	33	Host ACL Data Packet Length	States	Yes	
				Host SCO Data Packet Length			
				Host Total Num ACL Data Packets			
				Host Total Num SCO Data Packets			

EYSMACAXX SeriesTAIYO YUDEN Confidential
& Tentative

Control No. HD-AE-C080180	(6/11)	Control name Electrical characteristics
------------------------------	--------	--

HCI_Set_Event_Mask	0x0C01	3	1	Event Mask	States	Yes	
HCI_Set_Event_Filter	0x0C05	3	5	Filter Type	States	Yes	
				Filter Condition Type			
				Condition			
HCI_Set_Controller_To_Host_Flow_Control	0x0C31	3	31	Flow Control Enable	States	Yes	
HCI_Host_Number_Of_Completed_Packets	0x0C35	3	35	Number of Handles		Yes	
				Connection handle [I]			
				Host Num of Completed Packets [I]			
HCI_Read_Synchronous_Flow_Control_Enable	0x0C2E	3	2E		States	Yes	
				Synchronous Flow Control Enable			
HCI_Write_Synchronous_Flow_Control_Enable	0x0C2F	3	2F	Synchronous Flow Control Enable	States	Yes	

Link Information

HCI_Read_LMP_Handle	0x0420	1	20	Connection Handle	Status	Yes	
					Connection Handle		
					LMP_Handle		
					Reserved		
HCI_Read_Transmit_Power_Level	0x0C2D	3	2D	Connection Handle	States	Yes	
				Type	Connection Handle		
					Power Level		
HCI_Read_Link_Quality	0x1403	5	3	Connection Handle	Status	Yes	
					Connection Handle		
					Link Quality		
HCI_Read_RSSI	0x1405	5	5	Connection Handle	Status	Yes	
					Connection Handle		
					RSSI		
HCI_Read_Clock_Offset	0x041F	1	1F	Connection Handle		Yes	
HCI_Read_Clock	0x1407	5	7	Connection Handle	Status	Yes	
					Connection Handle		
				Which Clock	Clock		
					Accuracy		
HCI_Read_AFH_Channel_Map	0x1406	5	6	Connection Handle	Status	Yes	
					Connection Handle		
					AFH Mode		
					AFH Channel Map		

Authentication and Encryption

HCI_Read_Authentication_Enable	0x0C1F	3	1F		States	Yes	
					Authentication Enable		
HCI_Write_Authentication_Enable	0x0C20	3	20	Authentication Enable	States	Yes	
HCI_Read_Encryption_Mode	0x0C21	3	21		States	Yes	
					Encryption Mode		
HCI_Write_Encryption_Mode	0x0C22	3	22	Encryption Mode	States	Yes	
HCI_Link_Key_Request_Reply	0x040B	1	B	BD ADDR	Status	Yes	
				Link Key	BD ADDR		
HCI_Link_Key_Request_Negative_Reply	0x040C	1	C	BD ADDR	Status	Yes	
					BD ADDR		
HCI_PIN_Code_Request_Reply	0x040D	1	D	BD ADDR	BD ADDR	Yes	
				PIN Code Length			
				PIN Code			
HCI_PIN_Code_Request_Negative_Reply	0x040E	1	E	BD ADDR	Status	Yes	

EYSMACAXX SeriesTAIYO YUDEN Confidential
& Tentative

Control No. HD-AE-C080180	(7/11)	Control name Electrical characteristics
------------------------------	--------	--

HCI_Authentication_Requested	0x0411	1	11	Connection Handle		Yes	
HCI_Set_Connection_Encryption	0x0413	1	13	Connection Handle		Yes	
				Encryption Enable			
HCI_Change_Connection_Link_Key	0x0415	1	15	Connection Handle		Yes	
HCI_Master_Link_Key	0x0417	1	17	Key Flag		Yes	
HCI_Read_PIN_Type	0x0C09	3	9		States	Yes	
					PIN Type		
HCI_Write_PIN_Type	0x0C0A	3	A	PIN Type	States	Yes	
HCI_Read_Stored_Link_Key	0x0C0D	3	D	BD ADDR	States	Yes	
				Read All Flag	Max Num Keys		
					Num Keys Read		
HCI_Write_Stored_Link_Key	0x0C11	3	11	Num Keys To Write	States	Yes	
				BD ADDR [I]	Num Keys Written		
				Link Key [I]			
HCI_Delete_Stored_Link_Key	0x0C12	3	12	BD ADDR	States	Yes	
				Delete All Flag	Num Keys Deleted		
					Local Name		
HCI_Create_New_Unit_Key	0x0C0B	3	B		States	Yes	
HCI_User_Confirmation_Request_Reply	0x042C	1	2C	BD ADDR	Status	Yes	
HCI_User_Confirmation_Request_Negative_Reply	0x042D	1	2D	BD ADDR	Status	Yes	
HCI_User_Passkey_Request_Reply	0x042E	1	2E	BD ADDR	Status	Yes	
HCI_User_Passkey_Request_Negative_Reply	0x042F	1	2F	BD ADDR	Status	Yes	
HCI_Remote_OOB_Data_Request_Reply	0x0430	1	30	BD ADDR	Status	Yes	
HCI_Remote_OOB_Data_Request_Negative_Reply	0x0433	1	33	BD ADDR	Status	Yes	
HCI_Read_Local_OOB_Data	0x0C57	3	57		Status	Yes	
HCI_Write_Simple_Pairing_mode	0x0C56	3	56	Simple_Pairing_Mode	Status	Yes	
HCI_Read_Simple_Pairing_mode	0x0C55	3	55		Status	Yes	
HCI_Refresh_Encryption_Key	0x0C53	3	53	Connection_Handle	Status	Yes	

Testing

HCI_Read_Loopback_Mode	0x1801	6	1		States	Yes	
					Loopback Mode		
HCI_Write_Loopback_Mode	0x1802	6	2	Loopback Mode	Status	Yes	
HCI_Enable_Device_Under_Test_Mode	0x1803	6	3		Status	Yes	
HCI_Write_Simple_Pairing_Debug_mode	0x1804	6	4	Simple_Pairing_Debug_Mode	Status	Yes	

EYSMACAXX SeriesTAIYO YUDEN Confidential
& Tentative

Control No. HD-AE-C080180	(8/11)	Control name Electrical characteristics
------------------------------	--------	--

HCI EVENT LIST

Event Description	OpCode	Parameters	Status	Notes
Inquiry _Complete	0x01	Status	Yes	
Inquiry _Result	0x02	Num Responses	Yes	
		BD ADDR [I]		
		Page Scan Repetition Mode [I]		
		Page Scan Period Mode [I]		
		Page Scan Mode [I]		
		Class of Device [I]		
Connection _Complete	0x03	Status	Yes	
		Connection Handle		
		BD ADDR		
		Link Type		
		Encryption Mode		
Connection _Request	0x04	BD ADDR	Yes	
		Class of Device		
		Link Type		
Disconnection _Complete	0x05	Status	Yes	
		Connection Handle		
		Reason		
Authentication _Complete	0x06	Status	Yes	
		Connection Handle		
Remote _Name _Request _Complete	0x07	Status	Yes	
		BD ADDR		
		Remote Name		
Encryption _Change	0x08	Status	Yes	
		Connection Handle		
		Encryption Enable		
Change _Connection _Link _Key _Complete	0x09	Status	Yes	
		Connection Handle		
Master _Link _Key _Complete	0x0A	Status	Yes	
		Connection Handle		
		Key Flag		
Read _Remote _Supported _Features _Complete	0x0B	Status	Yes	
		Connection Handle		
		LMP Features		
Read _Remote _Version _Information _Complete	0x0C	Status	Yes	
		Connection Handle		
		LMP Version		
		Manufacture Name		
QoS _Setup _Complete	0x0D	LMP Subversion	Yes	
		Status		
		Connection Handle		
		Flags		
		Service Type		
		Token Rate		
		Peak Bandwidth		
Latency				
Command _Complete	0x0E	Delay Variation	Yes	
		Num HCI Command Packets		
		Command Opcode		
		Return Parameters		

EYSMACAXX SeriesTAIYO YUDEN Confidential
& Tentative

Control No. HD-AE-C080180	(9/11)	Control name Electrical characteristics
------------------------------	--------	--

Command_Status	0x0F	Status	Yes	
		Num HCI Command Packets		
		Command Opcode		
Hardware_Error	0x10	Hardware Code	Yes	
Flush_Occurred	0x11	Connection Handle	Yes	
Role_Change	0x12	Status	Yes	
		BD ADDR		
		New Role		
Number_Of_Completed_Packets	0x13	Number of Handles	Yes	
		Connection Handle [I]		
		HC Num HCI Data Packets [I]		
Mode_Change	0x14	Status	Yes	
		Connection Handle		
		Current Mode		
		Interval		
Return_Link_Keys	0x15	Num Keys	Yes	
		BD ADDR [I]		
		Link Key [I]		
PIN_Code_Request	0x16	BD ADDR	Yes	
Link_Key_Request	0x17	BD ADDR	Yes	
Link_Key_Notification	0x18	BD ADDR	Yes	
		Link Key		
Loopback_Command	0x19	HCI Command Packet	Yes	
Data_Buffer_Overflow	0x1A	Link Type	No	
Max_Slots_Change	0x1B	Connection Handle	Yes	
		LMP Max Slots		
Read_Clock_Offset_Complete	0x1C	Status	Yes	
		Connection Handle		
		Clock Offset		
Connection_Packet_Type_Change	0x1D	Status	Yes	
		Connection Handle		
		Packet Type		
QoS_Violation	0x1E	Connection Handle	No	
Page_Scan_Repetition_Mode_Change	0x20	BD ADDR	Yes	
		Page Scan Repetition Mode		
Flow_Specification_Complete	0x21	Status	Yes	
		Connection Handle		
		Flags		
		Flow direction		
		Service Type		
		Token Rate		
		Token Bucket Size		
		Peak Bandwidth		
Access Latency				
Inquiry_Result_with_RSSI	0x22	Num Responses	Yes	
		BD ADDR [I]		
		Page Scan Repetition Mode [I]		
		Page Scan Period Mode [I]		
		Page Scan Mode [I]		
		Class of Device [I]		
		Clock Offset [I]		
RSSI [I]				
Read_Remote_Extended_Features_Complete	0x23	Status	Yes	
		Connection Handle		
		Page Number		
		Maximum page number		
		Extended LMP Features		

EYSMACAXX SeriesTAIYO YUDEN Confidential
& Tentative

Control No. HD-AE-C080180	(10/11)	Control name Electrical characteristics
------------------------------	---------	--

Synchronous_Connection_Complete	0x2C	Status	Yes	
		Connection_Handle		
		BD_ADDR		
		Link_Type		
		Transmission_Interval		
		Retransmission_Window		
		Rx_Packet_Length		
		Tx_Packet_Length		
Synchronous_Connection_Changed	0x2D	Status	Yes	
		Connection_Handle		
		Transmission_Interval		
		Retransmission_Window		
		Rx_Packet_Length		
		Tx_Packet_Length		
Sniff_Subrating	0x2E	Status	Yes	
		Connection_Handle		
		Maximum_Transmit_Latency		
		Maximum_Receive_Latency		
		Minimum_Remote_Timeout		
Extended_Inquiry_Result	0x2F	Num_Responses	Yes	
		BD_ADDR		
		Page_Scan_Repetition_Mode		
		Reserved		
		Class_of_Device		
		Clock_Offset		
		RSSI		
Extended_Inquiry_Response				
Encryption_Key_Refresh_Complete	0x30	Status	Yes	
IO_Capability_Request	0x31	Connection_Handle	Yes	
IO_Capability_Response	0x32	BD_ADDR	Yes	
		IO_Capability		
		OOB_Data_Present		
		Authentication_Requirements		
User_Confirmation_Request	0x33	BD_ADDR	Yes	
User_Passkey_Request	0x34	Numeric_Value	Yes	
User_Passkey_Request	0x34	BD_ADDR	Yes	
Remote_OOB_Data_Request	0x35	BD_ADDR	Yes	
Simple_Pairing_Complete	0x36	Status	Yes	
		BD_ADDR		
Link_Supervision_Timeout_Changed	0x38	Connection_Handle	Yes	
		Link_Supervision_Timeout		
Enhanced_Flush_Complete	0x39	Connection_Handle	Yes	
User_Passkey_Notification	0x3B	BD_ADDR	Yes	
		Passkey		
Keypress_Notification	0x3C	BD_ADDR	Yes	
		Notification_Type		
Remote_Host_Supported_Features_Notification	0x3D	BD_ADDR	Yes	
		Host_Supported_Features		

EYSMACAXX Series

TAIYO YUDEN Confidential
& Tentative

Control No. HD-AE-C080180	(11/11)	Control name Electrical characteristics
------------------------------	---------	--

Module Stack

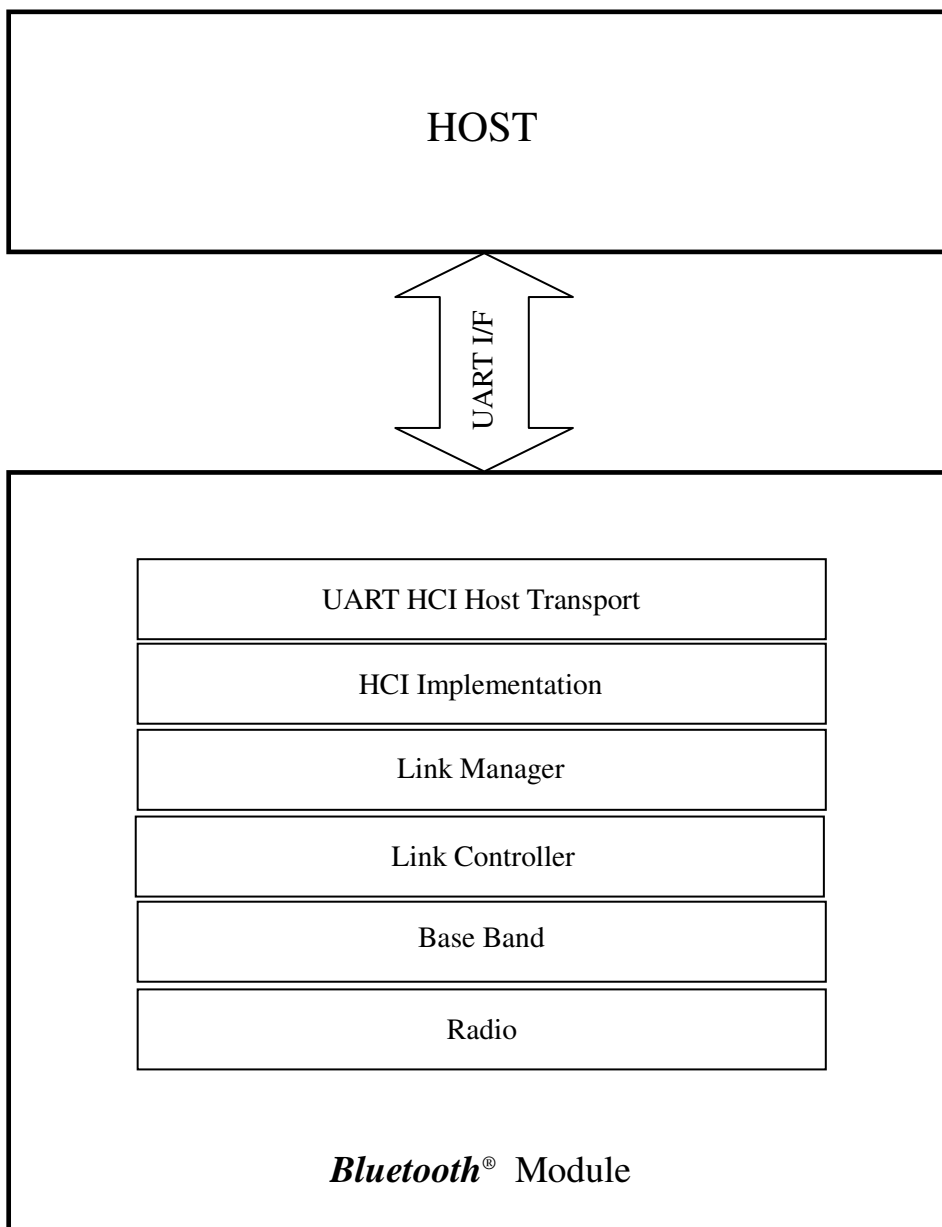

Note:

The protocol stack in the module is compliant with the Specification of the *Bluetooth*[®] System V2.1+EDR