



Chipsmall Limited consists of a professional team with an average of over 10 year of expertise in the distribution of electronic components. Based in Hongkong, we have already established firm and mutual-benefit business relationships with customers from,Europe,America and south Asia,supplying obsolete and hard-to-find components to meet their specific needs.

With the principle of “Quality Parts,Customers Priority,Honest Operation,and Considerate Service”,our business mainly focus on the distribution of electronic components. Line cards we deal with include Microchip,ALPS,ROHM,Xilinx,Pulse,ON,Everlight and Freescale. Main products comprise IC,Modules,Potentiometer,IC Socket,Relay,Connector.Our parts cover such applications as commercial,industrial, and automotives areas.

We are looking forward to setting up business relationship with you and hope to provide you with the best service and solution. Let us make a better world for our industry!



## Contact us

Tel: +86-755-8981 8866 Fax: +86-755-8427 6832

Email & Skype: info@chipsmall.com Web: www.chipsmall.com

Address: A1208, Overseas Decoration Building, #122 Zhenhua RD., Futian, Shenzhen, China





An  IXYS Company

*eZ80Acclaim!™ Product Family*

# Zilog Full-Featured TCP/IP Software Suite

Product Brief

PB015412-1211

## Introduction

The Zilog TCP/IP Software Suite solution, ZTP, is an integrated, preemptive multitasking operating system and set of TCP/IP protocols that has been optimized for embedded systems. ZTP works in conjunction with the award-winning eZ80Acclaim! family of Flash microcontrollers. It also provides standard network connectivity in a wide range of applications, such as industrial control, automation, facility management, IP appliances, and remote systems communication.

ZTP is optimized to allow quick development of these low-cost systems. Powered by the Zilog Real-Time Kernel (RZK), ZTP offers fully-featured operating system services, in addition to network services, while occupying minimal program memory. Your applications can be integrated with ZTP via its easy-to-use and well-documented application programming interface (API).

---

► **Note:** The ZTP standard release is integrated with and installed by the *ZDSII\_eZ80Acclaim!* install package.

---

ZTP supports the following TCP/IP protocols:

- IPv4, TCP, UDP, ARP and RARP
- ICMP, IGMP and DHCP/BOOTP

ZTP supports three physical interfaces:

- Ethernet 10/100
- PPP
  - On serial link with HDLC
  - On Ethernet with PPPoE
- 802.11 b/g Wireless LAN (wireless interface supports WEP, WPA and WPS2)

Building upon these field-proven core protocols, ZTP offers a rich set of higher-level TCP/IP services to

accelerate application development, and includes the following elements:

- HTTP/HTTPS server, TFTP client, SNMP agent, TELNET server and client, SMTP client, DNS client, TimeP client and Sntp client
- FTP server and client, plus an embedded Flash file system that works within the Flash and static RAM memories
- Local or remote run-time debugging operating system command shell

An industry-standard socket interface and native RZK APIs are the primary interfaces available to your applications for interfacing with the TCP/IP stack. These interfaces accelerate development time for network programmers who are already familiar with their socket interface. For new TCP/IP programmers, the native RZK APIs shorten the learning process. In addition, an internal mapping layer maintains a set of backward-compatible APIs to previous ZTP releases.

ZTP is royalty-free, configurable, scalable, and modular in design; it provides a rich set of features via easy-to-use and well-documented APIs. In addition, its features are highly optimized to the stringent memory and performance requirements typical of 8-bit embedded applications.

ZTP is available in a standard release package with an object library. It is also available in a source release package complete with full source code.

ZTP is currently available for Zilog's eZ80Acclaim! family of devices, including the eZ80F91, eZ80F92 and eZ80F93 microcontrollers, plus the eZ80L92 microprocessor.

## Architecture

The ZTP software suite is designed to be highly modular and scalable. It is broadly classified into three major subsystems:

**ZTP Drivers.** The ZTP driver subsystem is comprised of device drivers such as Ethernet, UART, I<sup>2</sup>C, SPI,

RTC, WLAN, plus protocol drivers such as PPP and HDLC.

**ZTP Core.** The ZTP core subsystem is comprised of TCP/IP protocols and Zilog’s real-time operating system. ZTP supports stream connections (TCP), datagram connections (UDP) and secure connections (SSL).

**ZTP Applications.** Most ZTP applications are comprised of high-level application protocols that use core components to perform standard network functions. An optional run-time shell interface is provided so that you can initiate shell commands using either a local RS-232 terminal or a remote terminal via Telnet.

The shell implements a rich set of informative debugging commands, and custom shell commands can be added. Many ZTP functions are initiated or monitored via the shell during run-time. For example, if a remote host initiates a Telnet client request, the ZTP shell provides a network virtual terminal to the remote host.

Another component of the ZTP applications subsystem is an embedded Flash file system, which supports multiple-disk volumes and operates in the Flash and RAM memory spaces. The Flash file system facilitates the easy handling of files over a network connection such as FTP and HTTP/HTTPS, and can be employed by the application to manage data files and directories. The Flash file system supports standard C APIs, such as `fopen`, `fclose`, etc.

ZTP application developers can enjoy flexibility toward using either the native RZK programming interface or a BSD socket-like interface to communicate with the network. The highly-configurable nature of ZTP thereby enables you to include only those components that are appropriate to the application, and exclude components that are not required to build your final binary image.

Figure 1 displays the ZTP architecture.

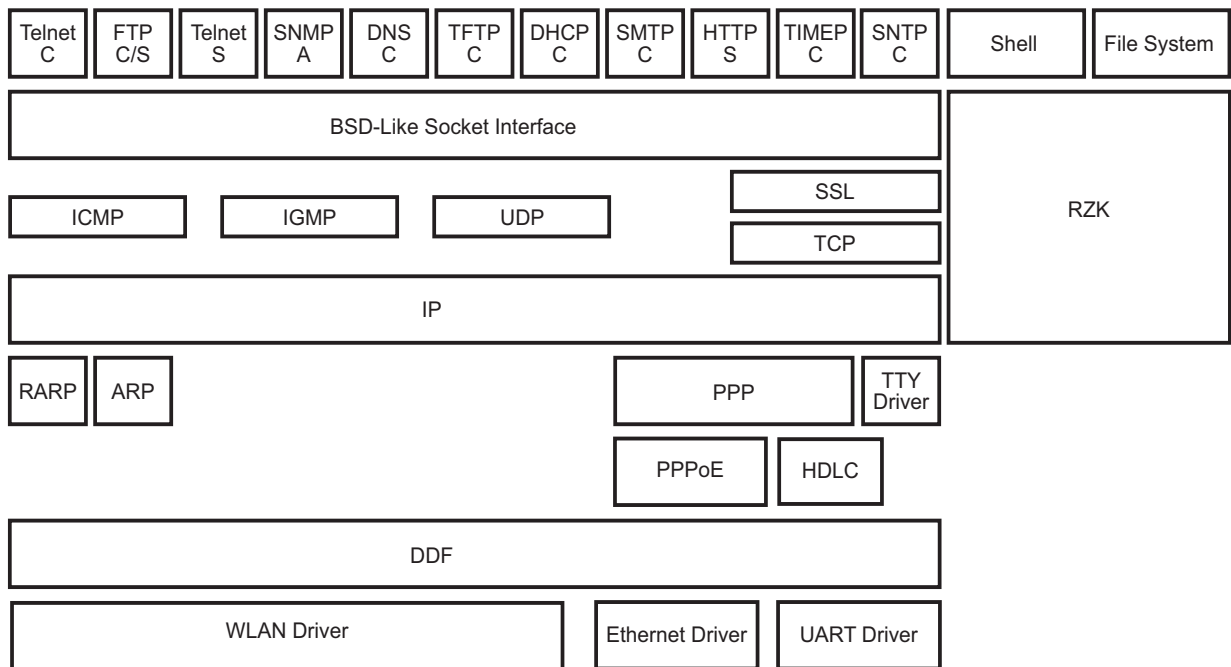

Legend: S = Server, C = Client, A = Agent

**Figure 1. ZTP Architecture Block Diagram**

## Features

ZTP has been optimized with the requirements of typical 8-bit applications in mind. In addition to its industry standard RFC-compliant protocols, the key features of ZTP include:

**HTTP Server.** An application protocol to retrieve hypertext documents from the World Wide Web. Java applets and CGI calls are supported, as are many standard website objects/file types. The HTTP1.1 Keep-Alive mechanism and HTTP1.1 basic and message digest (MD5-based) scheme authentication are also supported.

**HTTPS Server.** An application protocol that adds data privacy, data integrity and authentication features to HTTP using SSL technology (optional: included in a separate SSL plug-in package).

**Telnet Client.** An application protocol that makes it possible for you to connect and run programs on remote hosts. The protocol implements options such as *echo* and *suppress go ahead*.

**Telnet Server.** An application protocol that allows remote users to Telnet into a system.

**FTP Client/Server.** An application protocol that allows you to transfer files from one system to another system over a TCP/IP network. This protocol operates seamlessly with the RZK-embedded Flash file system.

**SNMP Agent.** An application protocol that makes network management information available to SNMP managers. ZTP implements SNMPv1, SNMPv2 and SNMPv3. SNMPv2 includes an additional `GetBulk` command, and SNMPv3 implements authentication and encryption.

**TFTP Client.** The Trivial file transfer protocol (TFTP) is a simple form of FTP. This protocol is implemented on top of the User Datagram Protocol (UDP). Because it is small, it lacks most of the features of FTP.

**DHCP Client.** An application protocol that dynamically requests an IP address from an available DHCP server on a TCP/IP network.

**SMTP Client.** An application protocol that is used to transfer mail reliably and efficiently; it supports *challenge/response* (CRAM MD5-based) digest scheme authentication.

**TimeP.** An application protocol that retrieves a time reference from a remote TimeP server on a TCP/IP network.

**SNTP Client.** An application protocol that gets time from the time server.

**PPPoE Client.** PPPoE uses the features of Ethernet and PPP standards. If PPPoE is used, *dial* from one machine to another over an Ethernet network using the DSL line to establish a point-to-point connection between the host and target.

See the [Documentation](#) section of this product brief for a listing of the ZTP manuals that fully describe these features.

## High Performance and Fast Context Switching

ZTP is powered by RZK, which can perform a context switch between threads in less than 12.5  $\mu$ s (measured on a 50 MHz eZ80F91 MCU running with 1 wait state in eZ80 bus mode). On this host platform, ZTP's high-performance core can transmit data on a UDP socket with a speed of 6Mbps. In the current ZTP release, this performance is reflected in the performance of the higher-layer network. Refer to the latest ZTP Release Notes for updated information.

## Small Memory Footprint

The memory footprint for the basic ZTP core is less than 60 KB. The memory footprint of ZTP when running application protocols varies based on the components being included. RAM requirements for ZTP depend on, but are not limited to, actual configuration, such as the number of application threads and the number of TCP/UDP connections supported at run time.

## Modular, Scalable and Configurable

ZTP is highly configurable and scalable; you can derive a light- to full-featured version per your application requirements. The modular design of ZTP enables you to include only those library objects that are required by your application, thereby saving memory space. The standard ZTP package is released as a set of libraries.

TCP/IP parameters, such as the number of UDP/TCP connections and the size of the UDP/TCP/ buffer, are configurable. System parameters, such as the number of objects required (threads, semaphores, etc) can be specified at compile time. ZTP allocates memory for the object control blocks based on the number of

objects specified in the configuration file. All of these compile-time configuration options make ZTP fully configurable, thereby enabling you to fine-tune it to your requirements.

For complete information about configuring ZTP, refer to the [Zilog TCP/IP Software Suite Programmer's Guide \(RM0041\)](#).

## Portability

ZTP applications can be easily migrated/ported to a custom eZ80<sup>®</sup> CPU-based hardware platform. Extensive user documentation is available for the standard ZTP release; see the [Documentation](#) section of this product brief for a listing of the ZTP manuals that fully describe these features.

## Powerful Kernel

Zilog's latest RZK supports both preemptive and cooperative multitasking. The RZK scheduler runs tasks of equal priority in round-robin sequence. Thread priority can be changed at run-time. RZK offers the following mechanisms for inter-thread communication and synchronization:

**Semaphores.** RZK provides both binary as well as counting semaphores, and implements a priority inheritance protocol to solve priority inversion issues.

**Message Queues.** RZK provides message queues for asynchronous communication between threads; high-priority messages can be placed in front of the queue.

**Event Groups.** Event groups are provided for control synchronization, and do not carry any information; an event group can accommodate a maximum of 24 events.

**Memory Management.** Fixed-size memory pools are provided for deterministic memory allocation, which are very useful for time-critical applications. RZK also supports variable-size memory allocation.

For complete information about the RZK kernel, refer to the following documents, which are available free for download from the Zilog website:

- [Zilog Real-Time Kernel Product Brief \(PB0155\)](#)
- [Zilog Real-Time Kernel User Manual \(UM0075\)](#)

- [Zilog Real-Time Kernel Reference Manual \(RM0006\)](#)

## Demonstration Examples

The standard ZTP package includes sample applications that demonstrate a number of ZTP features for easy reference. These demo applications can be used as a reference to start a new project with a new configuration. These samples are simple interactive applications that are used to demonstrate:

- Socket programming for network data transfer over Ethernet and PPP interfaces
- Raw data transfer ability of ZTP over serial peripherals such as UART, I<sup>2</sup>C and SPI using RZK's DDF
- A simple webserver application
- An FTP client demo
- A minimal configuration demo
- A *ping* API utility demo
- A TCP and UDP socket programming demo

These examples are available with ZDSII tool chains for the entire family of eZ80Acclaim!<sup>®</sup> microcontrollers.

## Development Tools

ZTP is built upon the Zilog Developer Studio Integrated Development Environment (ZDSII), which provides code editing, assembler/C Compiler/linker features, source-level debugging and project managing facilities for the quick and efficient development of embedded applications. ZDSII is included with all eZ80Acclaim! development kits.

## Packaging

The standard ZTP package for eZ80Acclaim! MCUs is supplied as C object library modules, complete with source files and application examples. A package with full source code is also available. For part number references, refer to the [Zilog TCP/IP Stack API Reference Manual \(RM0040\)](#).

## Documentation

The following documents comprehensively describe all the features, functions, and usage of ZTP, and are available with each release.

[Zilog TCP/IP Software Suite Quick Start Guide \(QS0049\)](#): enables you to install and get started with ZTP. It guides you through running sample applications.

[Zilog TCP/IP Software Suite Programmer's Guide \(RM0041\)](#): explains in detail different ZTP configurations, features, and also gives a detailed explanation of the sample applications. It also contains a section on ZTP performance numbers and FAQ.

[Zilog TCP/IP Stack API Reference Manual \(RM0040\)](#): a complete API reference manual for the eZ80Acclaim! product family.

## Ordering Information

Software Package	Part Number	Description	Support
Standard Release	NA	NA	Free support via <a href="http://www.zilog.com">www.zilog.com</a> ; free updates.
Source Release	eZ800000100KTS	Full ZTP source package integrated with ZDSII	Free support via <a href="http://www.zilog.com">www.zilog.com</a> ; one year of free updates.



**Warning:** DO NOT USE THIS PRODUCT IN LIFE SUPPORT SYSTEMS.

### LIFE SUPPORT POLICY

ZILOG'S PRODUCTS ARE NOT AUTHORIZED FOR USE AS CRITICAL COMPONENTS IN LIFE SUPPORT DEVICES OR SYSTEMS WITHOUT THE EXPRESS PRIOR WRITTEN APPROVAL OF THE PRESIDENT AND GENERAL COUNSEL OF ZILOG CORPORATION.

### As used herein

Life support devices or systems are devices which (a) are intended for surgical implant into the body, or (b) support or sustain life and whose failure to perform when properly used in accordance with instructions for use provided in the labeling can be reasonably expected to result in a significant injury to the user. A critical component is any component in a life support device or system whose failure to perform can be reasonably expected to cause the failure of the life support device or system or to affect its safety or effectiveness.

### Document Disclaimer

©2011 Zilog, Inc. All rights reserved. Information in this publication concerning the devices, applications, or technology described is intended to suggest possible uses and may be superseded. ZILOG, INC. DOES NOT ASSUME LIABILITY FOR OR PROVIDE A REPRESENTATION OF ACCURACY OF THE INFORMATION, DEVICES, OR TECHNOLOGY DESCRIBED IN THIS DOCUMENT. ZILOG ALSO DOES NOT ASSUME LIABILITY FOR INTELLECTUAL PROPERTY INFRINGEMENT RELATED IN ANY MANNER TO USE OF INFORMATION, DEVICES, OR TECHNOLOGY DESCRIBED HEREIN OR OTHERWISE. The information contained within this document has been verified according to the general principles of electrical and mechanical engineering.

eZ80 and eZ80Acclaim! are registered trademarks of Zilog, Inc. All other product or service names are the property of their respective owners.