



Chipsmall Limited consists of a professional team with an average of over 10 year of expertise in the distribution of electronic components. Based in Hongkong, we have already established firm and mutual-benefit business relationships with customers from,Europe,America and south Asia,supplying obsolete and hard-to-find components to meet their specific needs.

With the principle of “Quality Parts,Customers Priority,Honest Operation,and Considerate Service”,our business mainly focus on the distribution of electronic components. Line cards we deal with include Microchip,ALPS,ROHM,Xilinx,Pulse,ON,Everlight and Freescale. Main products comprise IC,Modules,Potentiometer,IC Socket,Relay,Connector.Our parts cover such applications as commercial,industrial, and automotives areas.

We are looking forward to setting up business relationship with you and hope to provide you with the best service and solution. Let us make a better world for our industry!



Contact us

Tel: +86-755-8981 8866 Fax: +86-755-8427 6832

Email & Skype: info@chipsmall.com Web: www.chipsmall.com

Address: A1208, Overseas Decoration Building, #122 Zhenhua RD., Futian, Shenzhen, China





eZ80F917050SBCG

**Zdots[®] SBC for
eZ80Acclaim*Plus!*[™]
Connectivity ASSP**

Product Specification

PS026102-1207



Warning: DO NOT USE IN LIFE SUPPORT

LIFE SUPPORT POLICY

ZILOG'S PRODUCTS ARE NOT AUTHORIZED FOR USE AS CRITICAL COMPONENTS IN LIFE SUPPORT DEVICES OR SYSTEMS WITHOUT THE EXPRESS PRIOR WRITTEN APPROVAL OF THE PRESIDENT AND GENERAL COUNSEL OF ZILOG CORPORATION.

As used herein

Life support devices or systems are devices which (a) are intended for surgical implant into the body, or (b) support or sustain life and whose failure to perform when properly used in accordance with instructions for use provided in the labeling can be reasonably expected to result in a significant injury to the user. A critical component is any component in a life support device or system whose failure to perform can be reasonably expected to cause the failure of the life support device or system or to affect its safety or effectiveness.

Document Disclaimer

©2007 by Zilog, Inc. All rights reserved. Information in this publication concerning the devices, applications, or technology described is intended to suggest possible uses and may be superseded. ZILOG, INC. DOES NOT ASSUME LIABILITY FOR OR PROVIDE A REPRESENTATION OF ACCURACY OF THE INFORMATION, DEVICES, OR TECHNOLOGY DESCRIBED IN THIS DOCUMENT. ZILOG ALSO DOES NOT ASSUME LIABILITY FOR INTELLECTUAL PROPERTY INFRINGEMENT RELATED IN ANY MANNER TO USE OF INFORMATION, DEVICES, OR TECHNOLOGY DESCRIBED HEREIN OR OTHERWISE. The information contained within this document has been verified according to the general principles of electrical and mechanical engineering.

Z8, Z8 Encore!, Z8 Encore! XP, Z8 Encore! MC, Crimzon, eZ80, ZNEO, Zdots, and eZ80Acclaim*Plus!* are trademarks or registered trademarks of Zilog, Inc. All other product or service names are the property of their respective owners.



**ISO 9001:2000
FS 507510**

Zilog products are designed and manufactured under an ISO registered 9001:2000 Quality Management System. For more details, please visit www.zilog.com/quality.

Revision History

Each instance in the Revision History reflects a change to this document from its previous revision. For more details, refer to the corresponding pages or appropriate links given in the table below.

Date	Revision Level	Description	Page No
December 2007	02	Updated Table 6 , Figure 8 , Figure 9 , 20 , 23 , 24 , and Figure 10 .	20 , 23 , 24 , and 25
July 2007	01	Original issue.	All

Table of Contents

Zdots® SBC for eZ80AcclaimPlus!™ Connectivity ASSP	1
Zdots® SBC for eZ80AcclaimPlus!™ Connectivity ASSP Features	1
eZ80AcclaimPlus!™ Connectivity ASSP Features	2
Block Diagram	3
Pin Description	4
Peripheral Bus Connector	4
Input/Output Connector	7
Onboard Component Description	12
Logic-Level Input/Outputs	12
Onboard Battery Backup	12
Ethernet PHY and RJ45 Connector	12
Ethernet LEDs	13
Fast Buffer (U10)	13
Memory	15
IrDA Transceiver	15
Reset Generator	16
Serial Interface Ports	16
Physical Dimensions	16
Absolute Maximum Ratings	19
Zdots Bill of Materials	20
Schematics	23
Customer Support	26

Zdots® SBC for eZ80AcclaimPlus!™ Connectivity ASSP

Zilog's Zdots® Single Board Computer (SBC) for eZ80AcclaimPlus!™ Connectivity Application Specific Standard Product (ASSP) is a compact, high-performance Ethernet SBC specially designed for the rapid development and deployment of embedded systems requiring control and internet/intranet connectivity.

This expandable module is powered by Zilog's latest power-efficient, high-speed, optimized pipeline architecture eZ80F91 connectivity ASSP, a member of eZ80AcclaimPlus! Zilog® family.

eZ80F91 is a high-speed single-cycle instruction-fetch microcontroller, which operates with a clock speed of 50 MHz. It can also operate in Z80®-compatible addressing mode (64 KB) or full 24-bit addressing mode (16 MB).

The peripheral-rich Zdots SBC makes it suitable for a variety of applications including industrial control, IrDA connectivity, communication, security, automation, point-of-sale terminals, and embedded networking applications.

Zdots® SBC for eZ80AcclaimPlus!™ Connectivity ASSP Features

Features of Zdots SBC for eZ80AcclaimPlus! Connectivity ASSP include:

- Factory-default operating clock frequency at 50 MHz
- 10/100 Base-T Ethernet PHY with RJ45 connector
- 512 KB fast SRAM
- 256 KB on-chip Flash memory
- 1 MB OFF-chip NOR Flash memory
- Battery-backed Real-Time Clock
- Input/Output connector which provides 32 general-purpose 5 V-tolerant I/O pinouts
- Zilog's industry-leading IrDA transceiver—Zilog ZHX1810
- Onboard connector provides I/O bus for external peripheral connections (IRQ, \overline{CS} , 24 address, and 8 data)
- Low-cost connection to carrier board via two 2x30 pin headers
- Small footprint 63.5 mm x 78.7 mm
- 3.3 V power supply
- Standard operating temperature range: 0 °C to +70 °C

eZ80AcclaimPlus!™ Connectivity ASSP Features

Features of eZ80AcclaimPlus! Connectivity ASSP include:

- Single-cycle instruction fetch, high-performance, pipelined eZ80® CPU core
- 256 KB of Flash memory and 8 KB of SRAM
- 10/100 Mbps Ethernet MAC with 8 KB frame buffer
- Low power features including SLEEP mode, HALT mode, and selective peripheral power-down control
- Two UARTs with independent baud rate generators and support for 9-bit operation
- SPI with independent clock generator
- I²C with independent clock generator
- Infrared data association (IrDA)-compliant infrared encoder/decoder
- New DMA-like eZ80 instructions for efficient block data transfer
- External interface with four chip selects, individual wait state generators, and an external WAIT input pin—supports Intel- and Motorola-style buses
- Flexible-priority vectored interrupts (both internal and external) and interrupt controller
- Real-time clock with on-chip 32 kHz oscillator, selectable 50/60 Hz input, and separate V_{DD} pin for battery backup
- Four 16-bit Counter/Timers with prescalers and direct input/output drive
- Watchdog Timer (WDT)
- 32 bits of general-purpose input/output (GPIO)
- JTAG and ZDI debug interfaces
- 144-pin LQFP package
- Supply voltage of 3.0 V to 3.6 V with 5 V tolerant inputs
- Standard operating temperature range: 0 °C to +70 °C

Block Diagram

Figure 1 displays the block diagram of Zdots SBC for eZ80AcclaimPlus!™ ASSP.

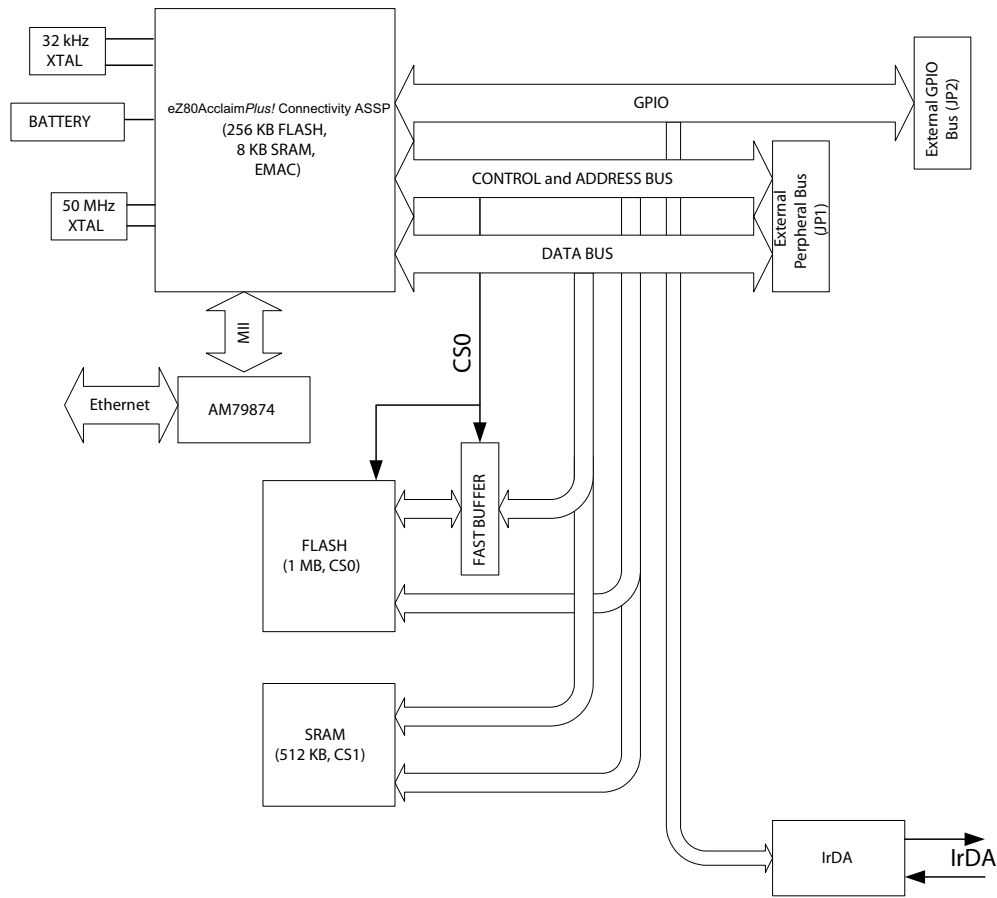

Figure 1. Zdots SBC for eZ80AcclaimPlus! ASSP Functional Block Diagram

Pin Description

Peripheral Bus Connector

Figure 2 displays the pin layout of the 60-pin Peripheral Bus Connector (JP1) of the Zdots®. Table 1 on page 5 describes the pins and their functions.

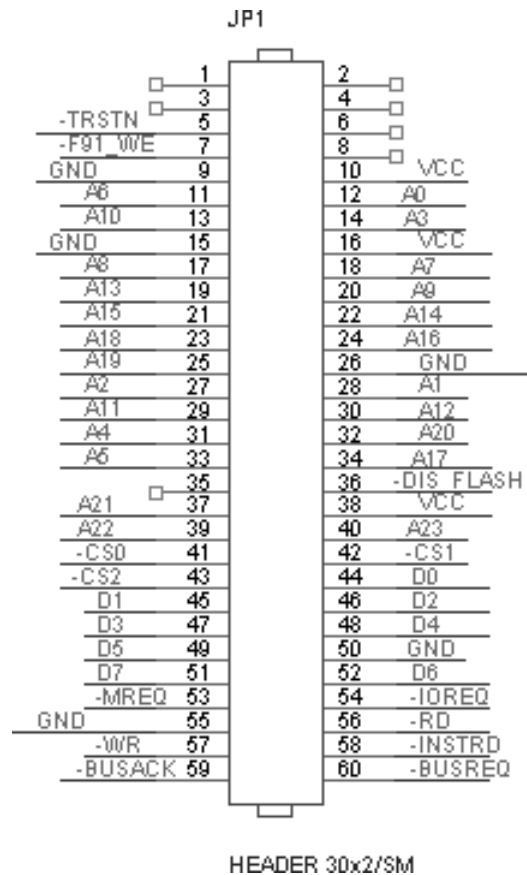

Figure 2. Zdots Peripheral Bus Connector Pin Configuration—JP1

► **Note:** All signals with an overline are active Low. For example, $\overline{B/W}$, for which WORD is active Low, and B/\overline{W} , for which BYTE is active Low.

Table 1. Zdots Peripheral Bus Connector Pin Identification*

Pin No	Symbol	Pull Up/Down*	Signal Direction	Comments
1	Reserved			
2	Reserved			
3	Reserved			
4	Reserved			
5	$\overline{\text{TRSTN}}$		Input	Reset for on-chip instrumentation (OCI).
6	Reserved			
7	$\overline{\text{F91_WE}}$	PU 10 kΩ	Input	A Low enables a Write to on-chip Flash memory. If this pin is unconnected, on-chip Flash memory is Write-protected.
8	Reserved			
9	GND			V _{SS} /Ground (0 V).
10	V _{CC}			3.3 V supply input pin.
11	A6		Bidirectional	
12	A0		Bidirectional	
13	A10		Bidirectional	
14	A3		Bidirectional	
15	GND			V _{SS} /Ground (0 V).
16	V _{CC}			3.3 V supply input pin.
17	A8		Bidirectional	
18	A7		Bidirectional	
19	A13		Bidirectional	
20	A9		Bidirectional	
21	A15		Bidirectional	
22	A14		Bidirectional	
23	A18		Bidirectional	
24	A16		Bidirectional	
25	A19		Bidirectional	
26	GND			V _{SS} /Ground (0 V).
27	A2		Bidirectional	

Table 1. Zdots Peripheral Bus Connector Pin Identification* (Continued)

Pin No	Symbol	Pull Up/Down*	Signal Direction	Comments
28	A1		Bidirectional	
29	A11		Bidirectional	
30	A12		Bidirectional	
31	A4		Bidirectional	
32	A20		Bidirectional	
33	A5		Bidirectional	
34	A17		Bidirectional	
35	Reserved			
36	$\overline{\text{DIS_Flash}}$	PU 10 k Ω	Input	A Low disables onboard Flash memory. Flash is enabled if $\overline{\text{DIS_Flash}}$ is not connected; CMOS input 3.3 V (5 V tolerant).
37	A21		Bidirectional	
38	V _{CC}			3.3 V supply input pin.
39	A22		Bidirectional	
40	A23		Bidirectional	
41	$\overline{\text{CS0}}$		Output	
42	$\overline{\text{CS1}}$		Output	
43	$\overline{\text{CS2}}$		Output	
44	D0	PU 4 k Ω	Bidirectional	
45	D1	PU 4 k Ω	Bidirectional	
46	D2	PU 4 k Ω	Bidirectional	
47	D3	PU 4 k Ω	Bidirectional	
48	D4	PU 4 k Ω	Bidirectional	
49	D5	PU 4 k Ω	Bidirectional	
50	GND			V _{SS} /Ground (0 V).
51	D7	PU 4 k Ω	Bidirectional	
52	D6		Bidirectional	
53	$\overline{\text{MREQ}}$		Bidirectional	
54	$\overline{\text{IORQ}}$		Bidirectional	

Table 1. Zdots Peripheral Bus Connector Pin Identification* (Continued)

Pin No	Symbol	Pull Up/Down*	Signal Direction	Comments
55	GND			V _{SS} /Ground (0 V).
56	\overline{RD}		Bidirectional	
57	\overline{WR}		Bidirectional	
58	\overline{INSTRD}		Output	
59	\overline{BUSACK}		Output	
60	\overline{BUSREQ}	PU 2 k Ω	Input	

***Notes**

1. External capacitive loads on \overline{RD} , \overline{WR} , \overline{IORQ} , \overline{MREQ} , D0–D7, and A0–A23 must be below 10 pF to satisfy timing requirements for the CPU.
2. All unused inputs must be pulled to either V_{DD} or GND, depending on their inactive levels, to reduce power consumption and to reduce noise sensitivity.
3. All inputs are CMOS level 3.3 V (5 V tolerant), except where otherwise noted.

Input/Output Connector

Figure 3 on page 8 displays the pin layout of the 60-pin I/O connector (JP2) of the Zdots. However, the eZ80® Development Platform features a 50-pin connector. The Zdots is designed to interface pin 60 of its JP2 connector to pin 50 of the eZ80 development platform's JP2 connector so that pins 1–10 of the Zdots overlap the edge of the eZ80 development platform. Table 2 on page 8 describes the pins.

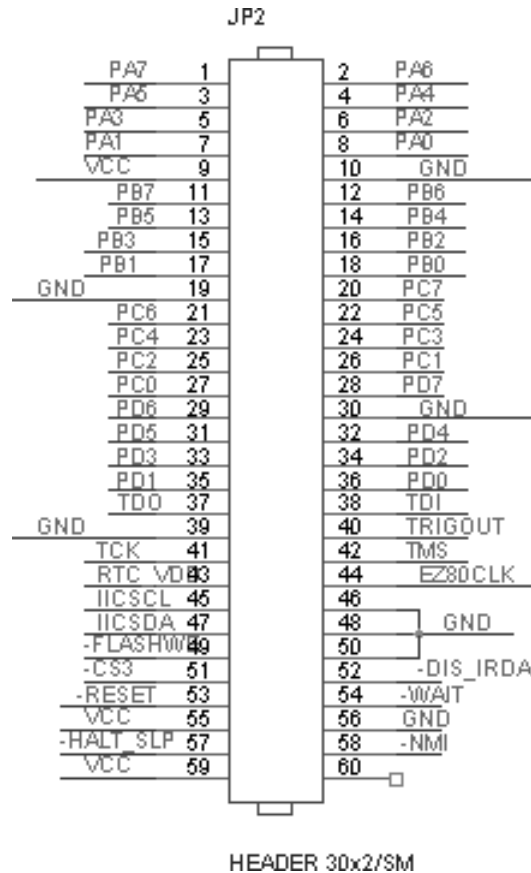

Figure 3. Zdots Input/Output Connector Pin Configuration—JP2

Table 2. Zdots Input/Output Connector Pin Identification*

Pin No	Symbol	Pull Up/Down	Signal Direction	Comments
1	PA7		Bidirectional	
2	PA6		Bidirectional	
3	PA5		Bidirectional	
4	PA4		Bidirectional	
5	PA3		Bidirectional	
6	PA2		Bidirectional	
7	PA1		Bidirectional	
8	PA0		Bidirectional	

Table 2. Zdots Input/Output Connector Pin Identification* (Continued)

Pin No	Symbol	Pull Up/Down	Signal Direction	Comments
9	V _{CC}			3.3 V supply input pin.
10	GND			V _{SS} /Ground (0 V).
11	PB7		Bidirectional	
12	PB6		Bidirectional	
13	PB5		Bidirectional	
14	PB4		Bidirectional	
15	PB3		Bidirectional	
16	PB2		Bidirectional	
17	PB1		Bidirectional	
18	PB0		Bidirectional	
19	GND			V _{SS} /Ground (0 V).
20	PC7		Bidirectional	
21	PC6		Bidirectional	
22	PC5		Bidirectional	
23	PC4		Bidirectional	
24	PC3		Bidirectional	
25	PC2		Bidirectional	
26	PC1		Bidirectional	
27	PC0		Bidirectional	
28	PD7		Bidirectional	
29	PD6		Bidirectional	
30	GND			V _{SS} /Ground (0 V).
31	PD5		Bidirectional	
32	PD4	PD 4 kΩ	Bidirectional	
33	PD3		Bidirectional	
34	PD2		Bidirectional	
35	PD1		Bidirectional	
36	PD0		Bidirectional	
37	TDO		Output	JTAG Data Output pin.

Table 2. Zdots Input/Output Connector Pin Identification* (Continued)

Pin No	Symbol	Pull Up/Down	Signal Direction	Comments
38	TDI/ZDA		Input	JTAG Data Input pin.
39	GND			V _{SS} /Ground (0 V).
40	TRIGOUT		Output	Active High trigger event indicator.
41	TCK/ZCL	PU 10 kΩ	Input	JTAG Input. High on reset enables ZDI mode; Low on reset enables OCI debug.
42	TMS	PU 10 kΩ	Input	JTAG Test Mode Select Input.
43	RTC_V _{DD}			RTC supply. For proper operation of the Zdots, this pin must be connected to the same power source that powers the module (as it is done on the Zilog® development platform).
44	EZ80CLK		Output	Synchronous CPU clock output.
45	I ² C _{SCL}	PU 4 kΩ	Bidirectional	I ² C Bus Clock.
46	GND			V _{SS} /Ground (0 V).
47	I ² C _{SDA}	PU 4 kΩ	Bidirectional	I ² C Data Clock.
48	GND		Power	V _{SS} /Ground (0 V).
49	FlashWE	PU 10 kΩ	Input	A Low enables a Write to external Flash memory boot block area. If this pin is unconnected, the Flash memory boot block area is Write-protected.
50	GND			V _{SS} /Ground (0 V).
51	CS3		Output	Used on the eZ80190, eZ80L92, eZ80F92, eZ80F93 devices and connected to the CS8900 EMAC.
52	DIS_IRDA	PU 10 kΩ	Input	A Low disables the onboard IRDA transceiver to use PC0/PC1 UART pins externally.
53	RESET	PU 2 kΩ	Bidirectional	Reset Output from module or push-button reset.
54	WAIT	PU 2 kΩ	Input	Driving the WAIT pin Low forces the CPU to provide additional clock cycles for an external peripheral or external memory to complete its Read or Write operation.
55	V _{CC}			3.3 V supply input pin.
56	GND			V _{SS} /Ground (0 V).

Table 2. Zdots Input/Output Connector Pin Identification* (Continued)

Pin No	Symbol	Pull Up/Down	Signal Direction	Comments
57	$\overline{\text{HALT_SLP}}$		Output, Active Low	A Low on this pin indicates that the CPU enters either HALT or SLEEP mode because of execution of either a HALT or SLP instruction.
58	$\overline{\text{NMI}}$	PU 10 k Ω	Schmitt-trigger Input, Active Low	The $\overline{\text{NMI}}$ input is a higher priority input than the maskable interrupts. It is always recognized at the end of an instruction, regardless of the state of the interrupt enable control bits. This input includes a Schmitt-trigger to allow RC rise times. This external $\overline{\text{NMI}}$ signal is combined with an internal NMI signal generated from the WDT block before being connected to the NMI input of the CPU.
59	V _{CC}			3.3 V supply input pin.
60	Reserved		NC	Reserved—No Connection.

***Notes**

1. External capacitive loads on $\overline{\text{RD}}$, $\overline{\text{WR}}$, $\overline{\text{IORQ}}$, $\overline{\text{MREQ}}$, D0–D7, and A0–A23 must be below 10 pF to satisfy timing requirements for the CPU.
2. All unused inputs must be pulled to either V_{DD} or GND, depending on their inactive levels, to reduce power consumption and to reduce noise sensitivity.
3. All inputs are CMOS level 3.3 V (5 V tolerant), except where otherwise noted.

Onboard Component Description

Logic-Level Input/Outputs

The I/O connector features 32 general-purpose 3.3 V CMOS I/O pins that can be used as outputs or inputs interfacing to external logic. All I/Os are 5 V tolerant. Some of the general-purpose I/O pins support dual mode functions (SPI, Timer I/O, UARTs, and bit I/O with edge- or level-triggered interrupt functions on each pin). For more information on eZ80AcclaimPlus!™ ASSP dual modes, refer to *eZ80F91 Product Specification (PS0192)*.

Onboard Battery Backup

An onboard Panasonic VL-1220-1VC 3 V Lithium battery powers the 32 kHz real-time clock when external power is removed. The battery is charged through diode CR1 and resistor R28 when external power is applied to the board.

Ethernet PHY and RJ45 Connector

The Zdots® contains Advanced Micro Devices' Am79C874 Media-Independent Interface (MII) and a HALO RJ45 with integrated magnetics (transformer and common-mode chokes) and two LED indicators.

The MII enables different modes of Ethernet communication, configurable by resistors R19, R21, R23, and R24. The Zdots is shipped with all four resistors installed. [Table 3](#) lists the available resistor settings and is excerpted from the Am79C874 data sheet published by AMD.

Table 3. Zdots MII Resistor Configuration

R24 ANEG	R19 (Tech[2])	R23 (Tech[1])	R21 (Tech[0])	Speed	Full-Duplex	ANEG-EN	Capabilities	ANEG
IN	IN	IN	IN	Yes ¹	Yes ¹	No	All	Disabled
IN	IN	IN	OUT	No	No	No	10HD	Disabled
IN	IN	OUT	IN	No	No	No	100HD	Disabled
IN	IN	OUT	OUT	No	No	No	100HD	Disabled
IN	OUT	IN	IN	Yes ¹	Yes ¹	No	All	Disabled
IN	OUT	IN	OUT	No	No	No	10FD	Disabled

Table 3. Zdots MII Resistor Configuration (Continued)

R24 ANEG	R19 (Tech[2])	R23 (Tech[1])	R21 (Tech[0])	Speed	Full-Duplex	ANEG-EN	Capabilities	ANEG
IN	OUT	OUT	IN	No	No	No	100FD	Disabled
IN	OUT	OUT	OUT	No	No	No	100FD	Disabled
OUT	IN	IN	IN	Yes ²	Yes ²	Yes ³	None	Enabled
OUT	IN	IN	OUT	Yes ²	Yes ²	Yes ³	10HD	Enabled
OUT	IN	OUT	IN	Yes ²	Yes ²	Yes ³	100HD	Enabled
OUT	IN	OUT	OUT	Yes ²	Yes ²	Yes ³	100HD, 10HD	Enabled
OUT	OUT	IN	IN	Yes ²	Yes ²	Yes ³	None	Enabled
OUT	OUT	IN	OUT	Yes ²	Yes ²	Yes ³	10FD/HD	Enabled
OUT	OUT	OUT	IN	Yes ²	Yes ²	Yes ³	100FD/HD	Enabled
OUT	OUT	OUT	OUT	Yes ³	Yes ²	Yes ³	All	Enabled

Notes

1. MII Register 0 (Speed and Duplex Bits) must be set by a MAC to achieve a link.
2. When autonegotiation is enabled, these bits are written but will be ignored by PHY.
3. The advertised abilities of MII Register 4 cannot exceed the abilities of MII Register 1. Autonegotiation must always be enabled.

Ethernet LEDs

The Ethernet connection is provided by the HALO RJ45 connector. It consists of two green LEDs that are located next to each other on the Zdots®. When PHY is receiving data, the left LED is ON. When the PHY is transmitting data, the right LED is ON.

Fast Buffer (U10)

The Zdots has a fast buffer that (see [Figure 1](#) on page 3) exists to prevent bus contention that occurs because of slow turn-off time of the module's external Flash and the fast bus turn-around time of the eZ80F91 (generic feature of the eZ80® family when it is used in NATIVE mode).

The problem related to bus contention when using eZ80 family of the microprocessors in NATIVE eZ80 mode is explained below, see [Figure 4](#) on page 14. For more details, refer to *eZ80F91 Product Specification (PS0192)*.

Bus contention occurs when two or more devices drive a common bus. The eZ80F91's CS0 drives the Flash CE. After the access to Flash, CS0 is driven High a maximum of 8.8 ns after the next rising edge of the Clock (T6 in [Figure 4](#)). The Flash turn-off time (T_{OD}) is 25 ns, which is the time from OE or CE going High to the Flash output drivers

going into High-Z mode, that is, after the end of the eZ80F91 Read access to Flash, it takes $8.8 \text{ ns} + 25 \text{ ns} = 33.8 \text{ ns}$ before Flash stops driving the data bus. At this point, the eZ80F91 device is already well into the next bus cycle.

Consider the next cycle to be Memory Write. During the Memory Write cycle, data (output) from the eZ80F91 device is valid not later than $T_3 = 7.5 \text{ ns}$, and the Write pulse is asserted not later than 4.5 ns after the falling edge of the Clock (14.5 ns from the rising edge if Clock is 50 MHz). It means that during $T_{\text{CON}} = (33.8 \text{ ns} - 7.5 \text{ ns}) = 26.3 \text{ ns}$; two devices drive the common Data Bus—the eZ80F91 device and Flash. In turn, data that is being written during the Write operation might be corrupted. The part used to isolate a slow Flash data bus from a fast eZ80F91 bus has 5.5 ns turn-off time, which reduces 25 ns part of the T_{CON} to 5.5 ns . As a result, bus contention still occurs, but its duration is not 26.3 ns , as described in the following equation:

$$\text{Time of contention} = (8.8 \text{ ns} - 7.5 \text{ ns} + 5.5 \text{ ns}) = 6.8 \text{ ns}$$

Data being written is not corrupted because the Write pulse is not yet asserted.

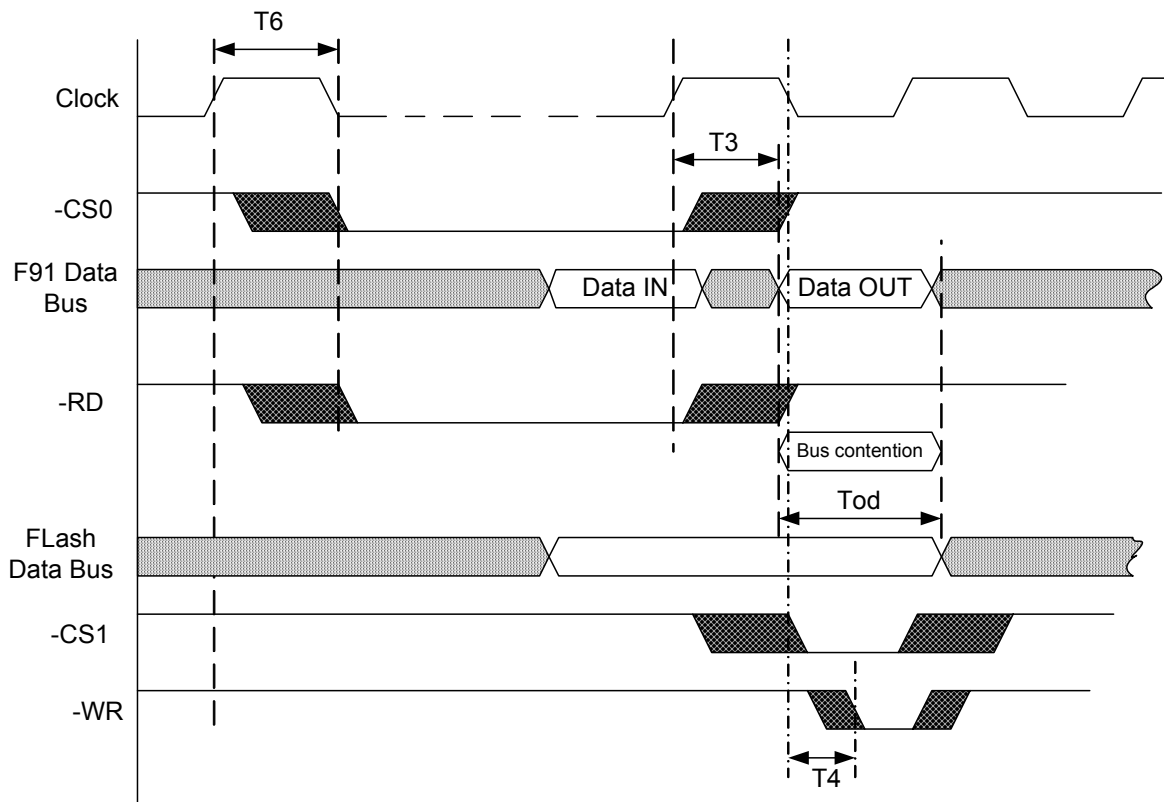

Figure 4. Bus Contention without the Zdots Fast Buffer Feature

Memory

The Zdots contains external Flash memory and the eZ80F91 connectivity ASSP contains internal Flash memory. To allow Read/Write access to Flash memory on the Zdots, there are two signals provided on connectors JP1 and JP2. A jumper JP3 on the module enables programming of on-chip Flash.

There is also a signal that duplicates the function of this jumper. [Table 4](#) describes the states of the signals and the status of the jumper for different modes.

Table 4. Flash Memory Programming Signals and Jumpers

Signal/Jumper	Function	State/Status
$\overline{\text{DIS_FLASH}}$	Controls Read/Write access to Zdots for eZ80AcclaimPlus! ASSP external Flash memory	When Low, access is enabled
$\overline{\text{FlashWE}}$	Controls Write operations to the boot block of Zdots for eZ80AcclaimPlus! ASSP external Flash memory	When Low, Write is enabled
$\overline{\text{JP3}}$	Controls Write access to eZ80F91 MCU on-chip Flash memory	When IN, Write is enabled
$\overline{\text{F91_WE}}$	Controls Write access to eZ80F91 MCU on-chip Flash memory	When Low, Write is enabled

The external Flash memory of Zdots has an access time of 100 ns. At least five wait states must be added to the cycle when accessing external Flash at 50 MHz clock speed. The eZ80F91 devices on-chip Flash is faster; its minimum access time is 60 ns, which requires only three wait states at 50 MHz.

There is 512 KB of fast SRAM on the Zdots. Access time is 12 ns, which requires one wait-state access. The eZ80F91's on-chip SRAM is used with zero wait states.

IrDA Transceiver

An onboard IrDA transceiver (Zilog ZHX1810) is connected to PD0 (TX), PD1 (RX), and PD2 (Shutdown, R_SD). The IrDA transceiver is of the LED type 870 nm Class 1.

The receiver supply current is 90–150 μA and the transmitter supply current is 260 mA when the LED is active. The IrDA transceiver is accessible via the IrDA controller attached to UART0 on the eZ80F91 device. The UART0 console and the IrDA transceiver cannot be used simultaneously.

To use the UART0 for console or to save power, the transceiver is disabled by the software or by an off-board signal when using the proper jumper selection. The transceiver is

disabled by setting PD2 (IR_SD) High or by pulling the $\overline{\text{DIS_IRDA}}$ pin on the I/O connector Low. The shutdown is used for power savings. To enable the IrDA transceiver, $\overline{\text{DIS_IRDA}}$ is left floating and PD2 is set to Low.

Reset Generator

The onboard Reset Generator Chip performs reliable Power-On Reset. The chip generates a reset pulse with a duration of 200 ms if the power supply drops below 2.93 V. This reset pulse ensures that the board always starts in a defined condition. The RESET pin on the I/O connector reflects the status of the RESET line. It is a bidirectional pin for resetting external peripheral components or for resetting the Zdots with a low-impedance output (for example, a 100 Ω push button).

Serial Interface Ports

The CPU contains two UARTs with programmable baud rate generators. UART0 is connected to GPIO PD[0:7] on the I/O connector. UART1 is connected to GPIO PC[0:7] on the I/O connector.

- **Note:** *Do not connect an RS-232 interface without level shifters. There are no RS-232 level shifters on the Zdots.*

Physical Dimensions

The footprint of the Zdots PCB is 63.5 mm x 78.7 cm. With an RJ-45 Ethernet connector, the overall height is 25 mm, see [Figure 5](#) on page 17.

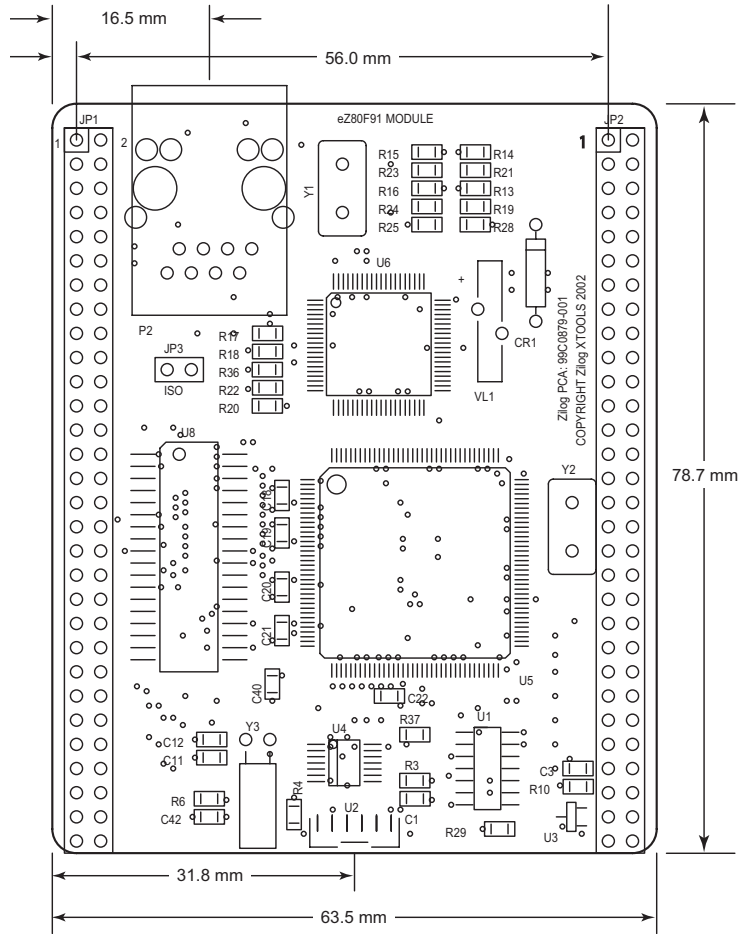

Figure 5. Physical Dimensions of the Zdots SBC

Figure 7 displays the bottom layer silk-screen of the Zdots.

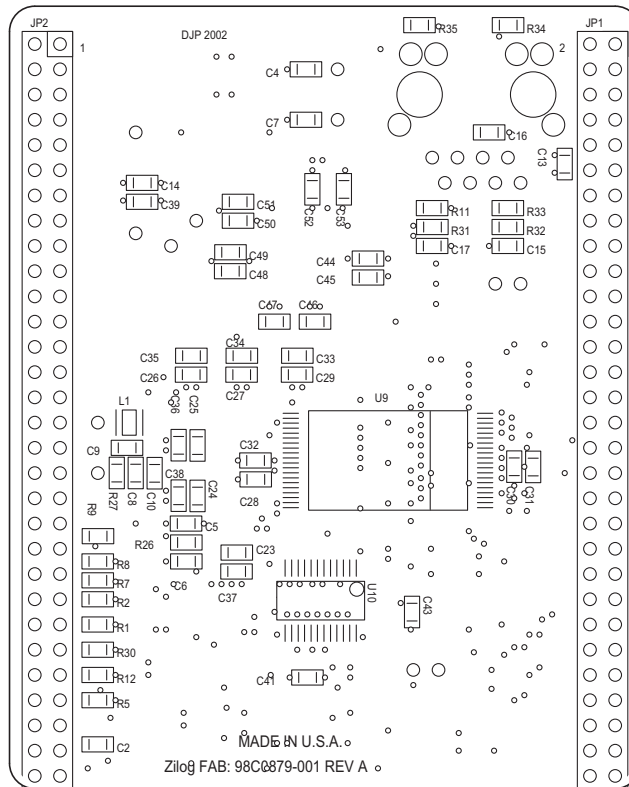

Figure 7. Zdots Module—Bottom Layer

Absolute Maximum Ratings

Stresses greater than those listed in Table 5 causes permanent damage to the device. These ratings are stress ratings only. Operation of the device at any condition outside those indicated in the operational sections of these specifications is not implied. Exposure to absolute maximum rating conditions for extended periods may affect device reliability. For improved reliability, unused inputs must be tied to one of the supply voltages (V_{DD} or V_{SS}).

Table 5. Absolute Maximum Ratings

Parameter	Minimum	Maximum	Units
Standard operating temperature	0	+70	°C
Storage temperature	-45	+85	°C

Table 5. Absolute Maximum Ratings (Continued)

Parameter	Minimum	Maximum	Units
Operating Humidity (RH @ 50 °C)	25%	90%	
Operating Voltage	—	3.6	V

Zdots Bill of Materials

Table 6 lists the installed components of the Zdots.

Table 6. Bill of Materials for the Zdots

Part Number	Part Name	Quantity	Jumper Location	Manufacturer
98C0879-001	Fab, Rev. B	1	—	Prime Technologies
35-0180-12	IC, SRAM, 512Kx8, 12 ns, 3 V, 36-SOJ	1	U8	Alliance Semi. AS7C34096-12JC
35-0016-05	IC, 74LVC04, 3.3 V, GATE, 14-SOIC	1	U1	Texas Instruments SN74LVC04AD
35-0720-10	IC, Flash, 1Mx8, 100 ns, 3 V, 40-TSSOP	1	U9	AMD AM29LV008BB-90ED
35-0719-00	IC, MAX6328, RESET, SOT-23	1	U3	Maxim Inc. MAX6328UR29-T
ZHX1810	IC, IR Transceiver, Low Profile	1	U2	Zilog® Inc. ZHX1810MV115THTR
35-0062-01	IC, 74LCX32, LV, QUAD OR, 14-TSSOP	1	U4	Fairchild Semi. 74LCX32MTC
35-0022-01	IC, AM7C874, PHY XCVR, 80QFP	1	U6	AMD AM79C874VC
eZ80F91	IC, eZ80F91, 50 MHz, 144VQFP	1	U5	Zilog Inc. eZ80F91
35-0731-00	IC, 74CBTLV3861PWR, 24-TSSOP	1	U10	Texas Instruments SN74CBTLV3861PWR
48-1013-01	Diode, TVS Array, XCVR Prot, 8-SOIC	1	U9	Semtec LCDA15C-6
17-2005-70	CAP, 1000 pF, 50 V, Ceramic Chip, 0603	15	C13, C14, C31-43	Panasonic ECJ-1VC1H561J
17-2005-66	CAP, 0.1 µF, 16 V, Ceramic Chip, 0603	28	C2,10, C15- 30, C44-53	Kemet Inc. C0603C104K5RAC
17-2005-54	CAP, 0.01 µF, 50 V, Ceramic Chip, 0603	1	C3	Panasonic ECJ-1VB1C103K

Table 6. Bill of Materials for the Zdots (Continued)

Part Number	Part Name	Quantity	Jumper Location	Manufacturer
17-2005-83	CAP, 0.33 μ F, 16 V, Ceramic Chip, 0603	1	C1	Panasonic ECJ-1VF1C334Z
17-2005-63	CAP, 560 pF, 50 V, Ceramic Chip, 0603	1	C6	Panasonic ECJ-1VC1H563K
17-2001-03	CAP, 12 pF, 50 V, Ceramic Chip, 0603	4	C9, C11, C12	Panasonic ECJ-1VC1H120J
17-2001-05	CAP, 22 pF, 50 V, CER CHIP, 0603	2	C4, C7	PANASONIC ECJ-1VC1H220J
17-2001-20	CAP, 270 pF, 50 V, CER CHIP, 0603	1	C5	PANASONIC ECJ-1VC1H271J
17-2001-01	CAP, 5 pF, 50 V, CER CHIP, 0603	1	C8	PANASONIC ECJ-1VC1H050C
48-0051-00	DIODE, 1N5817, RCTFR	1	CR1	MOTOROLA 1N5817
16-9005-33	INDUCTOR, 3.3 μ H, 20%, 1210 SMD	1	L1	PANASONIC ELJ-PA3R3MF
46-3001-03	Resistor, 10 K $\frac{3}{4}$, 1%, 1/16W, 0603 SMT	15	R3, 8, 10, R12-18, R20, 25, 29, 30, 37	Sprague 420CK472X2PD
46-3000-00	Resistor, 0 $\frac{3}{4}$, 1%, 1/16W, 0603 SMT	4	R19, 21, 23, 24	
46-3000-71	Resistor, 2.21K $\frac{3}{4}$, 1%, 1/16W, 0603 SMT	2	R5, R6	
46-3000-35	Resistor, 68 $\frac{3}{4}$, 1%, 1/16W, 0603 SMT	1	R3	
46-3000-02	RES, 2.2 $\frac{3}{4}$, 1%, 1/16W, 0603 SMT	1	R4	
46-3000-32	RES, 49.9 $\frac{3}{4}$, 1%, 1/16W, 0603 SMT	4	R11, 31, 32, 33	
46-3000-63	RES, 1K $\frac{3}{4}$, 1%, 1/16W, 0603 SMT	1	R22	
46-3000-56	RES, 499 $\frac{3}{4}$, 1%, 1/16W, 0603 SMT	1	R26	
46-3001-34	RES, 200 K $\frac{3}{4}$, 1%, 1/16W, 0603 SMT	1	R27	
46-3000-47	RES, 221 $\frac{3}{4}$, 1%, 1/16W, 0603 SMT	1	R28	
46-3000-51	RES, 332 $\frac{3}{4}$, 1%, 1/16W, 0603 SMT	2	R34, R35	
46-3001-75	RES, 10 M $\frac{3}{4}$, 1%, 1/16W, 0603 SMT	1	R38	