



Chipsmall Limited consists of a professional team with an average of over 10 year of expertise in the distribution of electronic components. Based in Hongkong, we have already established firm and mutual-benefit business relationships with customers from,Europe,America and south Asia,supplying obsolete and hard-to-find components to meet their specific needs.

With the principle of “Quality Parts,Customers Priority,Honest Operation,and Considerate Service”,our business mainly focus on the distribution of electronic components. Line cards we deal with include Microchip,ALPS,ROHM,Xilinx,Pulse,ON,Everlight and Freescale. Main products comprise IC,Modules,Potentiometer,IC Socket,Relay,Connector.Our parts cover such applications as commercial,industrial, and automotives areas.

We are looking forward to setting up business relationship with you and hope to provide you with the best service and solution. Let us make a better world for our industry!



## Contact us

Tel: +86-755-8981 8866 Fax: +86-755-8427 6832

Email & Skype: info@chipsmall.com Web: www.chipsmall.com

Address: A1208, Overseas Decoration Building, #122 Zhenhua RD., Futian, Shenzhen, China





# Optrex F-51405 5.2-inch 240x64 Monochrome-Graphic LCD

*White LED Backlighting, Industry-Standard Viewing Area*

Optrex's new F-51405 Series 5.2-inch diagonal module is an ultra-compact monochrome transmissive STN LCD that displays white characters or graphics on a blue background with a resolution of 240x64 dot pixels in an industry-standard viewing area. It provides a luminance of 120 nits minimum over the surface of the panel, is backlit by eight high-bright white LEDs (four on each side), and features economical chip-on-glass (COG) construction.

This lightweight (95 g) module (P/N F51405GNB-LW-AJ) measures a compact 149.5 mm W x 51.7 mm H x 9.8 mm D, with a viewing area of 130.2 mm W x 36.7 mm H, matching the industry-standard viewing area for 240x64 LCD modules.

The module's high level of component integration saves engineers valuable design, sourcing, debug and set-up time. It incorporates a backlight as well as mounting features, and an LCD controller driver with built-in RAM. It is easy to integrate into a wide variety of applications, and provides an ideal solution where a compact, lightweight, economical mid-size monochrome flat panel display is required.



## Applications

Optrex's F-51505 module is ideal for POS terminals, price checkers, musical instruments, audio equipment, and a wide range of industrial applications including process instrumentation, diagnostic devices and factory automation equipment.

## Features

- Displays characters and graphics
- 5.2-inch diagonal screen
- 240x64 dot pixel resolution
- 5:1 contrast ratio
- 0 to 50°C operating temperature range
- LCD controller driver with built-in RAM
- Compact, lightweight
- 8-bit parallel data transfer interface
- Economical chip-on-glass construction

## Backlight

- Luminance: 120 nits (cd/m<sup>2</sup>)
- Eight high-bright white LED backlights (four on each side)
- Power consumption: 615 mW (including LCD and backlight)

Optrex is a world leader in the design and manufacture of OEM liquid crystal displays (LCDs) for an expanding line of products that includes displays for telecommunications and non-PC Internet devices, test, measurement and diagnostic instruments, handheld data management equipment, and automotive and avionics displays. Founded in 1976, Optrex has followed an aggressive policy of growth and expansion and now serves customers through an extensive in-field network of applications engineers and more than 100 sales and distribution offices throughout the world. The Optrex technology palette includes Active-MLA (multi-line addressing), TFT (thin film transistor), VHC (very high contrast), STN (super twisted nematic), HPC (high performance color) for car audio applications, TFCC (trim fine crystal color) for color mobile products, and OLED (organic light emitting diode).

Model Name	F-51405GNB-LW-AJ
Module Type	STN monochrome-graphic
Display Operating Mode	Transmissive, blue/white
Screen Size (inch)	5.2-inch diagonal
Display Format (dot)	240 x 64
Active Area (HxV mm)	130.2 x 36.7
Dot Pitch (HxV mm)	0.53 x 0.53
Dot Size (mm)	0.51 x 0.51
Outline Dimensions (WxHxD mm)	149.5 x 51.7 x 9.8
LCD Driving Voltage	12.4 V typ. @ 25°C
Response Time (ms)	230 ms
Backlight	8 high-bright white LEDs
Luminance (cd/m <sup>2</sup> )	120
Contrast Ratio	5:1
Viewing Direction	6 o'clock
Viewing Angle	H: +/- 45°; V: -40°/+30°
Data Transfer	8-bit parallel data transfer
Module Mass (g)	95
Operating Temperature Range	0°C to +50°C
Storage Temperature Range	-20°C to +70°C

Note: Specifications are subject to change without notice.

F-51405GNB-LW-AJ

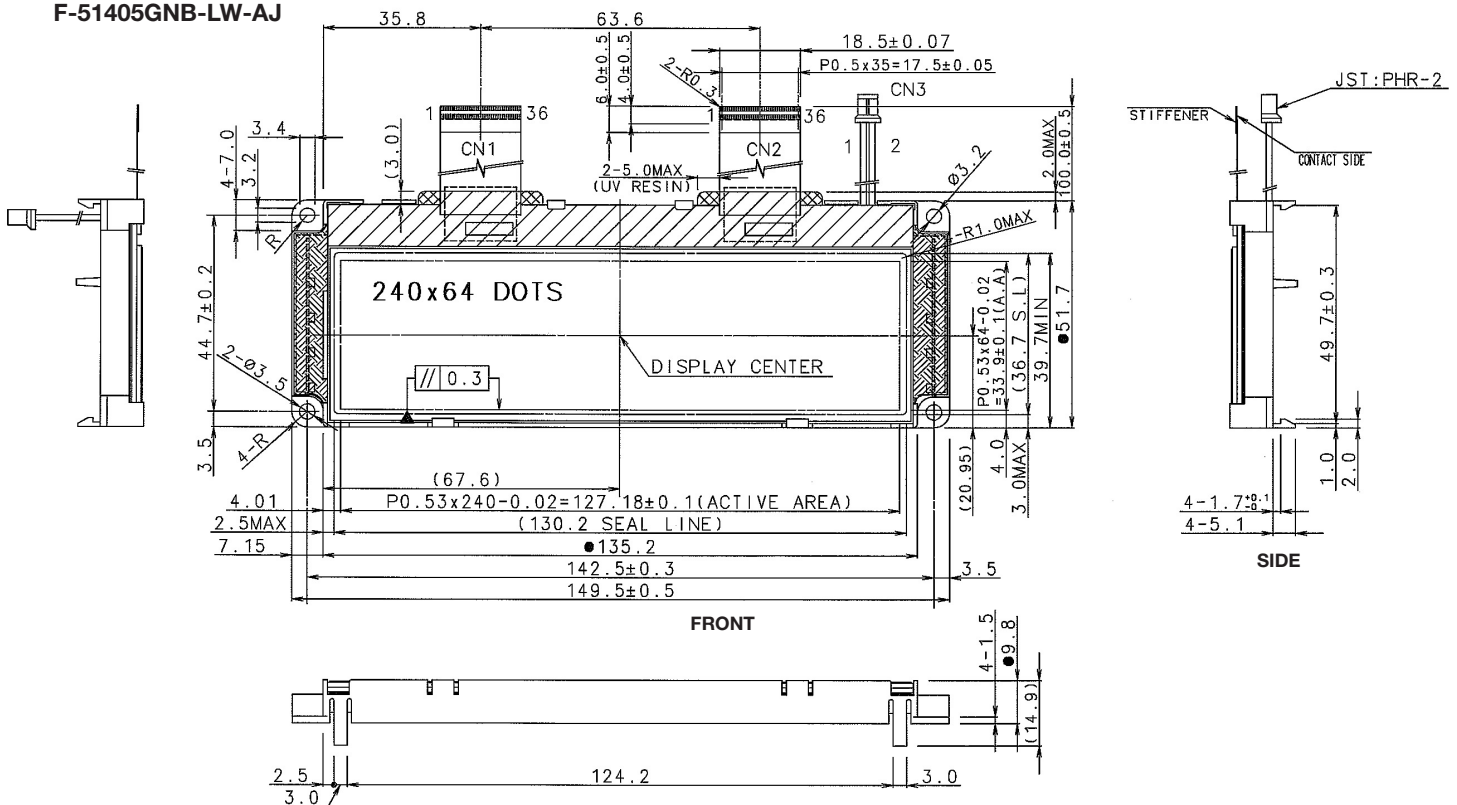

### Ask about the Optrex Value-Added Program

Unlimited custom design capabilities for anything from simple connector attachments to sophisticated LCD module integration with plastic housing, buttons, custom circuitry and firmware design.

For complete technical specifications call 734-416-8500 or visit our website at [www.optrex.com](http://www.optrex.com)



Optrex America, Inc.  
46723 Five Mile Road • Plymouth, MI 48170  
Tel: 734-416-8500 • Fax: 734-416-8520

FPD Total Solution Provider